



# ICBO Evaluation Service, Inc.

A subsidiary corporation of the International Conference of Building Officials

5360 WORKMAN MILL ROAD

• WHITTIER, CALIFORNIA 90601-2299

• (562) 699-0543  
FAX (562) 695-4694

## ACCEPTANCE CRITERIA FOR TESTING OF FIRE DOORS AND WINDOWS UNDER POSITIVE PRESSURE

AC84

January 1998

### PREFACE

Evaluation reports issued by the ICBO Evaluation Service, Inc. (ICBO ES), are based upon performance features of the *Uniform Building Code*<sup>™</sup>, *ICBO Uniform Mechanical Code*<sup>™</sup> and related codes. Section 104.2.8 of the *Uniform Building Code* is the primary charging section upon which evaluation reports are issued. Section 104.2.8 reads as follows:

The provisions of this code are not intended to prevent the use of any material, alternate design or method of construction not specifically prescribed by this code, provided any alternate has been approved and its use authorized by the building official.

The building official may approve any such alternate, provided the building official finds that the proposed design is satisfactory and complies with the provisions of this code and that the material, method or work offered is, for the purpose intended, at least the equivalent of that prescribed in this code in suitability, strength, effectiveness, fire resistance, durability, safety and sanitation.

The building official shall require that sufficient evidence or proof be submitted to substantiate any claims that may be made regarding its use. The details of any action granting approval of an alternate shall be recorded and entered in the files of the code enforcement agency.

The attached acceptance criteria for the general code sections noted has been issued to provide all interested parties with guidelines on implementing performance features of the codes. The attached acceptance criteria was developed and adopted following public hearings conducted by the Evaluation Committee. If the criteria is an updated version from a previous edition, solid vertical lines ( █ ) in the outer margin within the criteria indicate a technical change or addition from the previous edition. Deletion indicators ( ▸ ) are provided in the outer margins where a paragraph or item has been deleted if the deletion resulted from a technical change. This criteria may be revised from time to time as the need dictates.

ICBO ES may consider alternate criteria, provided the proponent submits valid data demonstrating that the alternate criteria are at least equivalent to the attached criteria and otherwise meet the applicable performance requirements of the codes. Notwithstanding that a material, type or method of construction, or equipment, meets the attached acceptance criteria, or that it can be demonstrated that valid alternate criteria are equivalent and otherwise meet the applicable performance requirements of the codes, if the material, product, system or equipment is such that either unusual care in its installation or use must be exercised for satisfactory performance, or malfunctioning is apt to cause unreasonable property damage or personal injury or sickness relative to the benefits to be achieved by the use thereof, ICBO ES retains the right to refuse to issue or renew an evaluation report.

Published by the

**International Conference of Building Officials**

5360 WORKMAN MILL ROAD • WHITTIER, CALIFORNIA 90601-2298

Copyright © 1998 ICBO Evaluation Service, Inc.

PRINTED IN THE U.S.A.

# ACCEPTANCE CRITERIA FOR TESTING OF FIRE DOORS AND WINDOWS UNDER POSITIVE PRESSURE

## 1.0 INTRODUCTION

**1.1 Scope:** The purpose of this criteria is to provide a procedure for recognition of fire doors and windows in ICBO Evaluation Service, Inc. (ICBO ES), evaluation reports under the 1997 *Uniform Building Code*<sup>™</sup> (UBC). This criteria is applicable to side-hinged or pivoted swinging doors, and window assemblies, including glass block and other light-transmitting assemblies, used in wall openings to retard the passage of fire.

### 1.2 Reference Documents:

**1.2.1** ICBO ES Acceptance Criteria for Quality Control Manuals (AC10).

**1.2.2** ICBO ES Acceptance Criteria for Test Reports and Product Sampling (AC85).

**1.2.3** 1997 UBC Standard 7-2, Fire Tests of Door Assemblies.

**1.2.4** 1997 UBC Standard 7-4, Fire Tests of Window Assemblies.

## 2.0 BASIC INFORMATION AND TEST REPORTS

### 2.1 Sampling:

Sampling of products for testing must be done by a testing laboratory or quality control agency accredited by ICBO ES or recognized by the National Evaluation Service, Inc. (NES), and the laboratory or agency must ensure that products are representative of typical construction.

### 2.2 Test Reports:

Test reports must comply with the ICBO ES Acceptance Criteria for Test Reports and Product Sampling (AC85). Test reports must be issued by a testing laboratory specifically accredited by ICBO ES or recognized by the NES for conducting tests under positive pressure in accordance with UBC Standards 7-2 or 7-4, as applicable to the tested assembly.

### 2.3 Quality Control:

A quality control manual prepared in concert with an ICBO ES accredited quality control agency, or with a compliance assurance/inspection agency recognized by the NES, is necessary for all products recognized in the report. The quality control manual shall comply with the ICBO ES Acceptance Criteria for Quality Control Manuals (AC10).

### 2.4 Identification:

All products recognized under this criteria shall be identified with an approved label or listing mark of an ICBO ES/NES accredited/recognized agency, indicating the fire-protection rating under a positive pressure test. The label or listing mark must be permanently affixed in accordance with Section 713.3 of the code.

## 3.0 REQUIRED DATA

### Fire Tests:

**3.1** Report(s) of tests for fire door assemblies, conducted in accordance with UBC Standard 7-2.

**3.2** Report(s) of tests for fire window assemblies, conducted in accordance with UBC Standard 7-4.

## 4.0 SUPPLEMENTAL COMMENTS ON TESTING/ RECOGNITION

**4.1** Furnace pressures shall be continuously monitored throughout the entire test period. A suitable recording instrument shall be used, providing a chart or graph plotting the furnace pressures (positive or negative) as a function of time, at

intervals not exceeding one minute. There shall be two pressure probes used, and these shall be located as follows:

**4.1.1** 40 inches (1016 mm) or less above the top of the sill.

**4.1.2** At the top of the furnace.

The probes shall be placed so that the centerlines of the sensing holes are positioned 6 inches  $\pm$  1 inch (152 mm  $\pm$  25 mm) from the surface of the exposed face of the test assembly, but in no case closer than 18 inches (457 mm) from the edge of the furnace. The probes used to measure furnace pressures may be moved to accommodate deflection of the test assembly, to keep the centerline of the sensing holes within the required distance from the surface of the test assembly. The probes are to be run horizontally through the wall and into the furnace. No change in vertical elevation of the probes or tubing is to be made within the test furnace. Data recording shall provide continuous monitoring of the output of an electronic pressure transducer in the range of  $\pm$  0.25 inch w.c. (62.2 Pa), with an accuracy of  $\pm$  1 percent. Pressure measurements shall be made such that the furnace pressure is referenced to the laboratory ambient pressure within one foot (305 mm), vertically, of the furnace probe location. Transducer location and pressure tubing shall be arranged to prevent temperature changes and stack effects from influencing the accuracy of the measurements. Figure 1 shows details of the tube sensor probe for monitoring furnace pressures.

**4.2** Reduced-scale testing, when used for justification of alternate or interchangeable components for a recognized assembly, must be based on: (1) the full-scale test; (2) a reduced-scale test replicating the full-scale test; and (3) a reduced-scale test, incorporating the desired change, which is then compared to the results derived from a reduced-scale test replicating the full-scale test.

**4.3** Recognition of fire-door installations in wall assemblies other than those tested (i.e., wood stud, masonry, steel stud/gypsum wallboard) will be governed by the conditions of the listing. Justification must be provided for installation in construction alternate to that tested.

**4.4** Extension of listings based on "worst-case" evaluations must be substantiated by tests (reduced or full-scale) or other non-proprietary data related to testing under positive pressure.

**4.5** Door and window assemblies shall have a unique label that indicates they have been tested under positive pressure. Labels on doors used for stair enclosures, horizontal exits and exit passageways must additionally include the temperature rise rating of "250°F (121°C) maximum", "450°F (232°C) maximum", "650°F (343°C) maximum" or "greater than 650°F (343°C)", as applicable, as developed during the test.

**4.6** Glazed systems; existing fire-rated hardware installed at, or above, the neutral pressure plane; and extension of installation details to similar doors must be justified by testing.

**4.7** Substantiation by testing is needed for recognition of frames tested separately from doors, and such recognition will be considered on a case-by-case basis. The revised deflection criteria in Section 7.209.3 of 1997 UBC Standard 7-2 and the effects of positive pressure require substantiation of the types or classes of products that are eligible for recognition without testing as a system.

**4.8** Extension of ICBO ES recognition to the negative pressure protocol, on doors tested under positive pressure, requires analysis and a statement from the testing laboratory that justifies such an extension of data.

**4.9** Use of the cotton pad is required to address the effects of cracks, seams or similar openings for doors rated for a tem-

perature rise to 650°F (343°C) or less in which openings develop during fire tests. If these openings allow the passage of gases which ignite the cotton pad, this shall constitute failure of the test.

**4.10** Glazing in openings is limited to the maximum size tested in either direction.

**4.11** Excessive amounts of smoke shall be determined by using a 14-inch-wide-by-7-inch-high (356 mm by 178 mm) exit sign, centrally located above the door(s) under test. The bottom edge of the sign shall be mounted within four inches (102 mm) of the top of the door frame. The color and design of the lettering on the exit sign shall be in high contrast with the background. The word "EXIT" shall be in block letters 6 inches (152 mm) in height, with a stroke of not less than  $\frac{3}{4}$  inch (19.1 mm). Complete obscuration of the exit sign, when viewed from a distance of 20 feet  $\pm$  5 feet (6096 mm  $\pm$  1524 mm) from the vertical

plane of the door, on a line normal to the center of the test door(s), shall constitute failure of the test. Visibility of the exit sign shall be monitored for the entire classification period of the fire test, and shall be documented in the test report.

**4.12** Recognition of components requires justification, and can be considered on the basis of reduced-scale tests within the guidelines outlined in Section 4.2.

**4.13** "Engineering evaluations" used by testing laboratories and listing agencies to justify components must be based on non-proprietary test data which shall be submitted to ICBO ES upon request.

**4.14** Recognition of components versus recognition of the complete assembly (as tested) can be considered when data or justification is provided which addresses the effects of positive pressure on the specific components.

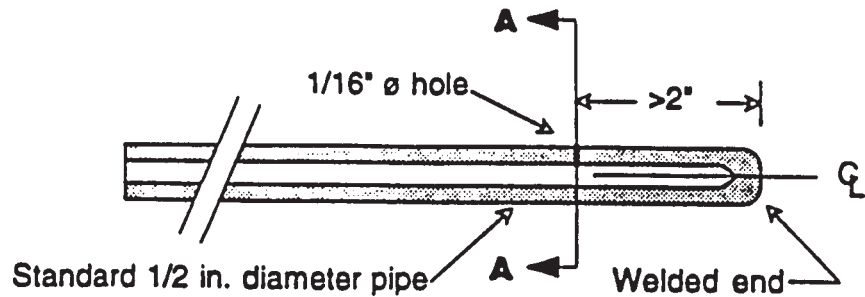

### CROSS-SECTION ALONG PROBE AXIS

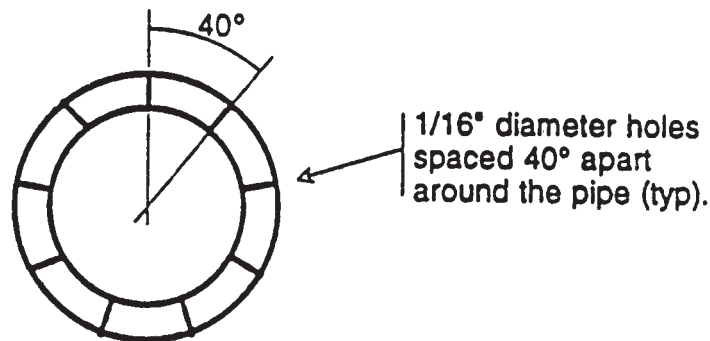

### SECTION A-A

For SI: 1 inch = 25.4 mm.

FIGURE 1—TUBE SENSOR