

ACCEPTANCE CRITERIA FOR RIM BOARD PRODUCTS

AC124

Approved October 2004

Effective November 1, 2004

(Editorially revised July 2010)

Previously approved July 2000, January 1997

PREFACE

Evaluation reports issued by ICC Evaluation Service, LLC. (ICC-ES), are based upon performance features of the International family of codes and other widely adopted code families, including the Uniform Codes, the BOCA National Codes, and the SBCCI Standard Codes. Section 104.11 of the *International Building Code*® reads as follows:

The provisions of this code are not intended to prevent the installation of any materials or to prohibit any design or method of construction not specifically prescribed by this code, provided that any such alternative has been approved. An alternative material, design or method of construction shall be approved where the building official finds that the proposed design is satisfactory and complies with the intent of the provisions of this code, and that the material, method or work offered is, for the purpose intended, at least the equivalent of that prescribed in this code in quality, strength, effectiveness, fire resistance, durability and safety.

Similar provisions are contained in the Uniform Codes, the National Codes, and the Standard Codes.

This acceptance criteria has been issued to provide all interested parties with guidelines for demonstrating compliance with performance features of the applicable code(s) referenced in the acceptance criteria. The criteria was developed and adopted following public hearings conducted by the ICC-ES Evaluation Committee, and is effective on the date shown above. All reports issued or reissued on or after the effective date must comply with this criteria, while reports issued prior to this date may be in compliance with this criteria or with the previous edition. If the criteria is an updated version from the previous edition, a solid vertical line (|) in the margin within the criteria indicates a technical change, addition, or deletion from the previous edition. A deletion indicator (→) is provided in the margin where a paragraph has been deleted if the deletion involved a technical change. This criteria may be further revised as the need dictates.

ICC-ES may consider alternate criteria, provided the report applicant submits valid data demonstrating that the alternate criteria are at least equivalent to the criteria set forth in this document, and otherwise demonstrate compliance with the performance features of the codes. Notwithstanding that a product, material, or type or method of construction meets the requirements of the criteria set forth in this document, or that it can be demonstrated that valid alternate criteria are equivalent to the criteria in this document and otherwise demonstrate compliance with the performance features of the codes, ICC-ES retains the right to refuse to issue or renew an evaluation report, if the product, material, or type or method of construction is such that either unusual care with its installation or use must be exercised for satisfactory performance, or if malfunctioning is apt to cause unreasonable property damage or personal injury or sickness relative to the benefits to be achieved by the use of the product, material, or type or method of construction.

Acceptance criteria are developed for use solely by ICC-ES for purposes of issuing ICC-ES evaluation reports.

ACCEPTANCE CRITERIA FOR RIM BOARD PRODUCTS (AC124)

1.0 INTRODUCTION

1.1 Purpose: The purpose of this acceptance criteria is to establish requirements for rim boards used in wood-framed construction to be recognized in an ICC Evaluation Service, LLC. (ICC-ES), evaluation report under the 2009 and 2006 *International Building Code*® (IBC), the 2009 and 2006 *International Residential Code*® (IRC), the BOCA® *National Building Code/1999* (BNBC), the 1999 *Standard Building Code*® (SBC), and the 1997 *Uniform Building Code*™ (UBC). Bases of recognition are IBC Section 104.11, IRC Section 104.11, BNBC Section 106.4, SBC Section 103.7, and UBC Section 104.2.8.

1.2 Scope:

1.2.1 This criteria provides minimum criteria for vertical and in-plane lateral load transfer capacity, durability performance, and quality assurance of rim boards. For purposes of this criteria, rim board depth is limited to a maximum of 24 inches (610 mm). This acceptance criteria only considers end use in dry service conditions, such as in weather-protected construction where the average equilibrium moisture content for wood framing is less than 16 percent.

1.2.2 A rim board is a continuously supported (across the full width) structural element located at the joist elevation in an end bearing wall or parallel to the joist framing that is the full depth of the joist space and manufactured in minimum continuous 8-foot-long (2.44 m) segments for the length of the wall, and which is used for any combination of the following:

- To transfer, from above to below, all vertical loads at the rim board location.
- To provide diaphragm attachment (sheathing to top edge of rim board).
- To transfer in-plane lateral loads from the diaphragm to the wall plate below.
- To provide lateral support to the joist or rafter (resistance against rotation) through attachment to the joist or rafter.
- To provide closure for ends of joists or rafters.
- To provide attachment base for siding and/or exterior deck ledger.

1.3 Referenced Standards:

1.3.1 2009 and 2006 *International Building Code*® (IBC), International Code Council.

1.3.2 2009 and 2006 *International Residential Code*® (IRC), International Code Council.

1.3.3 BOCA® *National Building Code/1999* (BNBC).

1.3.4 1999 *Standard Building Code*® (SBC).

1.3.5 1997 *Uniform Building Code*™ (UBC).

1.3.6 ASTM D 9-09ae1, Standard Terminology Relating to Wood and Wood-based Products, ASTM International.

1.3.7 ASTM D 1037-06a, Standard Test Methods for Evaluating Properties of Wood-Base Fiber and Particle Panel Materials, ASTM International.

1.3.8 ASTM D 2395-07ae1, Standard Test Methods for Specific Gravity of Wood and Wood-Based Materials, ASTM International.

1.3.9 ASTM D 4442-07, Standard Test Methods for Direct Moisture Content Measurement of Wood and Wood-Base Materials, ASTM International.

1.3.10 ASTM D 5055-05, Standard Specification for Establishing and Monitoring Structural Capacities of Prefabricated Wood I-joists, ASTM International.

1.3.11 ASTM D 5456-05a, Standard Specification for Evaluation of Structural Composite Lumber Products, ASTM International.

1.3.12 ASTM F 1667-05, Standard Specification for Driven Fasteners: Nails, Spikes, and Staples, ASTM International.

1.4 Definitions:

1.4.1 Prefabricated Wood I-joist Rim Boards: Prefabricated wood I-joist rim boards shall comply with the ICC-ES Acceptance Criteria for Prefabricated Wood I-joists (AC14). Prefabricated wood I-joist rim boards shall have a minimum flange width of 1.5 inches (38 mm). Manufacturing tolerances for wood I-joist rim board material shall be as specified in the I-joist manufacturing standard. The vertical and lateral load transfer capacity limitations specified in Table 1 shall be applicable to prefabricated wood I-joist rim boards.

1.4.2 Rectangular Wood-based Rim Boards: Rectangular wood-based rim boards are structural composite lumber, complying with the ICC-ES Acceptance Criteria for Structural Wood-based Products (AC47); or wood-based panel products such as oriented strand board (OSB) complying with PS-2, plywood complying with PS-1 or PS-2, or waferboard complying with PS-2. The material used as wood-based rim boards shall comply with code requirements and applicable consensus standards listed in the code, or shall be covered in an evaluation report. Thickness of rectangular rim board material shall comply with Table 1. The minimum thickness of rectangular rim board material shall be 1 inch (25.4 mm). Rectangular rim board material shall be manufactured to the following depth tolerances: :0.031 inch, +0.125 inch (:0.80 mm, +3.22 mm).

1.4.3 Insulated Rim Boards: Insulated rim boards consist of a polyurethane foam-plastic insulation core with two minimum 1/2-inch-thick (12.7) OSB structural skins and solid-sawn wood perimeter framing members. The OSB skins are stapled to the wood members at the perimeters of the insulated rim boards. The foam-plastic core shall comply with the ICC-ES Acceptance Criteria for Foam Plastic Insulation (AC12); the OSB structural wood-based skins shall comply with PS-2; the solid-sawn wood framing members shall be identified with a grade mark of a lumber grading or inspection agency that has been approved by an accreditation body that complies with PS-20 or equivalent procedures; and the staples shall comply with ASTM F 1667. Manufacturing tolerances for insulated rim board materials shall be as specified in the rim board manufacturing standard. If the insulated rim board relies on adhesives, including the polyurethane foam-plastic insulation core, for structural performance, compliance

ACCEPTANCE CRITERIA FOR RIM BOARD PRODUCTS (AC124)

with the ICC-ES Acceptance Criteria for Sandwich Panel Adhesives (AC05) is required.

1.4.4 Wood Terminology: Standard definitions of wood terms given in ASTM D 9 are applicable to this criteria.

2.0 BASIC INFORMATION

2.1 General: The following information shall be submitted:

2.1.1 Product Description: Complete information concerning material specifications, thickness, size and the manufacturing process.

2.1.2 Installation Instructions: Installation instructions shall be submitted. The instructions shall include any special instructions required for the product, such as nailing at tongue-and-groove edges, as well as weather protection and handling requirements. In cases where attachment requirements, lateral support details and bearing or connection requirements are not adequately covered by general notes, standard sketches and charts shall be included with the installation instructions, or specific job drawings shall properly cover these requirements.

2.1.3 Packaging and Identification: A description of the method of packaging and field identification of the product. Identification provisions shall include the evaluation report number, product and company name, plant location or number, the name or logo of the inspection agency, and a means of establishing the date of manufacture. The marking shall also include the thickness of the rim board. To allow for easy field identification, all identification marking shall be legible and durable and as a minimum shall last through typical handling, distribution, jobsite storage and installation. The vertical and lateral load transfer capacity limitations specified in Table 1 shall be applicable to insulated rim boards.

2.2 Testing Laboratories: Testing laboratories shall comply with Section 2.0 of the ICC-ES Acceptance Criteria for Test Reports (AC85) and Section 4.2 of the ICC-ES Rules of Procedure for Evaluation Reports.

2.3 Test Reports: Test reports shall comply with AC85.

2.4 Product Sampling: Sampling of the rim board for tests under this criteria shall comply with Section 3.1 of AC85.

3.0 TEST AND PERFORMANCE REQUIREMENTS

3.1 General:

3.1.1 Specimens for qualification testing shall be representative of the population being evaluated. When a modification to the manufacturing process results in a reduction in properties as indicated by the quality control program, new qualification testing is required.

3.1.2 Moisture content and specific gravity shall be measured and reported for each specimen tested in the qualification program. Measurement for moisture content shall be in accordance with ASTM D 4442, and measurement for specific gravity shall be in accordance with ASTM D 2395.

3.1.3 Rectangular wood-based rim boards qualified under this criteria shall be subject to the limitations shown in Table 1, based on product thickness.

3.2 Allowable Vertical Uniform Load Transfer Capacity:

3.2.1 The vertical uniform load transfer capacity of a rim board shall be limited to the lesser of the tested vertical uniform load capacity as determined in Section 3.2.2 (without adjustment for duration of load) or the calculated load capacity resulting in buckling, as determined in Section 3.2.3.

3.2.1.1 The allowable compression perpendicular-to-the-grain value for the sill plate and floor sheathing shall be included in the final analysis.

3.2.1.2 Design of the rim board/wall detail shall include considerations for stability and transfer of vertical loads from the wall above to the wall below without imparting significant load to the joist, unless adequate performance of the detail is provided by documented tests.

3.2.1.3 The minimum allowed spacing of the nails driven into the rim board edge (in the L- X plane, X direction as shown in Figure 1) shall be set to prevent unusual splitting of the rim board.

3.2.2 Vertical load test capacity of rim boards shall be determined in accordance with the following:

3.2.2.1 For rectangular and insulated rim board products, a minimum of ten specimens of each depth and thickness shall be tested for each grade and species. As an alternative, testing can be limited to the most critical depth and thickness. The minimum specimen length shall be 12 inches (305 mm).

3.2.2.2 For prefabricated wood I-joists, a minimum of ten specimens of maximum depth, minimum web thickness and rout configuration shall be tested for each type of flange material (sawn lumber or SCL, species and size), using the joist product with the minimum flange width. As an alternative, testing can be limited to the most critical combination. The minimum specimen length shall be 12 inches (305 mm).

3.2.2.3 A uniform compression load shall be applied on the edge of the specimen parallel to the L- X plane in the X direction (see Figure 1) at a uniform rate. A pre-load, not to exceed 10 percent of the anticipated ultimate load, shall be applied, after which total depth (crosshead) deformation versus load readings shall be taken continuously or at least every 0.01 inch (0.25 mm) until the ultimate load or the 0.06-inch (1.5 mm) deformation limit is reached. A uniform compression load rate, which causes failure in approximately two minutes, shall be applied. See Figure 2.

3.2.2.4 The tested vertical uniform load capacity shall be determined from the test results of Section 3.2.2.3 and shall be the lesser of the average ultimate load divided by 3.0 or the average load from the tests at a deformation of 0.06 inch (1.5 mm).

3.2.3 The calculated buckling capacity for each width, depth, grade and species of rim board shall be developed in accordance with accepted engineering principles. The buckling length coefficient, K_e , shall not be less than 0.90 for rectangular sections and 0.65 for web buckling (web in

ACCEPTANCE CRITERIA FOR RIM BOARD PRODUCTS (AC124)

a rout) between flanges. The appropriate modulus of elasticity (MOE) shall be determined from the mechanical properties of the basic material.

3.3 Fastener Capacities: Fastener capacities are required for (1) connection of the diaphragm to the rim board top edge; (2) attachment of the rim board to the supporting wall plate; (3) attachment of the rim board to the joists; (4) attachment of exterior wall siding to the rim board; and (5) attachment of an exterior deck ledger. Nail capacities for items 1 through 4 and bolt and lag screw capacities for item 5 shall be determined in accordance with the fastener requirements noted in the ICC-ES Acceptance Criteria for Structural Wood-based Products (AC47), or the NDS, as applicable. As an alternative, lag screw lateral load capacity for item 5 is permitted to be determined in accordance with the test method noted in Section 6.5 of APA PRR-401.

3.4 Lateral Load Transfer Capacity:

3.4.1 The lateral load transfer capacity of a rim board product shall be determined in accordance with this section.

3.4.1.1 For rectangular and insulated rim board products, a minimum of ten assemblies of each combination of rectangular rim board species, thickness, and at the maximum depth shall be tested. Other combinations may be considered, provided satisfactory test data and analysis are submitted.

3.4.1.2 For prefabricated wood I-joists, a minimum of ten assemblies containing the thinnest web and flange and the deepest joist in each series of prefabricated wood I-joists shall be tested. Other combinations may be considered provided satisfactory test data and analysis are submitted.

3.4.1.3 A test assembly shall consist of rim board, sheathing, I-joists, and sill plate, as shown in Figure 3.

3.4.1.4 Dimensions for each component of the assembly shall meet the requirements given in Table 2.

3.4.1.5 The minimum nailing schedule for the test assembly shall follow the requirements given in Table 3. The first and last nails between sheathing and rim board (edge nails) shall be 3 inches (76 mm) from each rim board end. Nails between sheathing and I-joist shall be 3 inches (76 mm) from each I-joist end. The first and last toe nails between rim board and sill plate shall be 3 inches (76 mm) from each rim board end.

3.4.1.6 Joist spacing for the assembly shall not be less than 24 inches (610 mm).

3.4.1.7 The assembly shall be fabricated at least 12 hours before mechanical testing.

3.4.2 The assemblies prepared in accordance with Section 3.4.1.1 through 3.4.1.7 shall be tested as follows:

3.4.2.1 Loads shall be applied through the sill plate while the sheathing reacts through full-width bearing, or vice versa. Vertical restraints such as rollers that do not interfere with the lateral resistance or other similar devices may be used to provide vertical restraints on the assembly to avoid overturning. These restraints, however, shall not interfere with the lateral deformation of the assembly in the direction parallel to the loading.

3.4.2.2 Assembly deformations shall be measured based on the relative lateral displacements between the sill plate and sheathing along the entire length of the rim board. Vertical displacements caused by overturning forces, if any, shall be isolated from the measurements of lateral deformations.

3.4.2.3 The loading rate shall not exceed 450 lbf (2003 N) per minute.

3.4.2.4 The assembly shall be loaded to ultimate load or 0.4-inch (10 mm) lateral deformation, whichever comes first. No preload shall be applied. Load and deformation readings shall be taken at approximately equal load increments.

3.4.3 For I-joist rim boards and wood-based rectangular rim boards, the maximum lateral load transfer capacity for each assembly is equal to the maximum load determined from Section 3.4.2.4 divided by the rim board length. The lateral load transfer capacity for each rim board combination shall be the average of the maximum load capacities divided by 2.8. This lateral load transfer capacity shall not be increased for any load duration.

3.4.4 For insulated rim boards, the lateral load transfer capacity shall be limited to the lesser of the tested lateral load capacity as determined in Section 3.4.3, or the calculated lateral load capacity of the OSB sheathing and the fasteners resisting in-plane shear forces. Values of fasteners shall be determined in accordance with the NDS or an evaluation report.

3.4.5 The lateral load transfer capacity determined from Section 3.4.3 or 3.4.4 is applicable to a shallower rim board of the same thickness and species combination.

3.5 Concentrated Load Transfer Capacity: Concentrated load capacity testing is required for rectangular wood-based rim boards, I-joist rim boards, and insulated rim boards when the rim board depth exceeds 16 inches (403 mm).

3.5.1 A minimum of ten specimens of each species, thickness and critical depth, with a minimum length of 16 inches (406 mm), shall be tested.

3.5.2 The specimens shall be tested per Section 3.2.2.3 with the exception that a concentrated load shall be applied through a 4.5-inch-long (115 mm) steel bar, with a minimum thickness of 0.50 inch (12.5 mm) and a width at least equal to the rim board thickness, at the top edge of the rim board specimen. The 4.5-inch (115 mm) length of the steel bar shall be centered on the 16-inch (406 mm) length of the test specimen.

3.5.3 The concentrated load transfer capacity shall be determined from the test results for each species and thickness, and shall be the lesser of the average maximum load divided by 3.0, or the average load from the tests at a deformation of 0.06 inch (1.5 mm).

3.5.4 To qualify as rim board under this section, the minimum required concentrated load transfer capacity shall be 3,500 pounds (15.6 kN) (working stress design load).

4.0 DURABILITY

4.1 General: Sections 4.2 and 4.3 are applicable to rectangular wood-based rim boards and insulated rim boards.

ACCEPTANCE CRITERIA FOR RIM BOARD PRODUCTS (AC124)

4.2 Thickness Swell:

4.2.1 Ten specimens shall be taken per product panel or sample from a minimum of five panels or samples. Five specimens from each panel or sample shall be conditioned to a constant weight and moisture content (see note 37 in ASTM D 1037) as follows: Relative humidity of 65 percent ± 5 percent and a temperature of 68°F ± 11°F (20°C ± 6°C.). Five matching specimens shall not be conditioned. All specimens shall be 5.9 inches by 5.9 inches (150 mm by 150 mm), minimum, by the product thickness.

4.2.2 Specimen thickness measurements shall be taken to the nearest 0.002 inch (0.05 mm) at four points: midway along each of the four sides, at a distance of 1.0 inch (25 mm) from the edge. The measuring device used shall have flat contacting anvils with a minimum diameter of 0.75 inch (20 mm). Pressure on the contacting surfaces shall not be greater than 10 psi (70 kPa) nor less than 5 psi (35 kPa).

4.2.3 All specimens shall be submerged horizontally in minimum 68°F (20°C) clear water for 24 hours. All specimens shall then be removed and suspended to drain for 10 minutes before remeasuring.

4.2.4 The thickness swell of each panel shall be calculated to the nearest 1 percent in accordance with the following formula:

$$TS = \left(\frac{t_{24} - t_0}{t_0} \right) \times 100$$

where:

- $T.S.$ = Thickness swell, in percent, after 24-hour soak.
 t_{24} = The sum of the 20 thickness measurements from each group of five specimens after the 24-hour soak.
 t_0 = The sum of the 20 original thickness measurements from each group of five specimens.

4.2.5 The average calculated thickness swell for all specimens from a five-panel sample originally conditioned in accordance with Section 4.2.1 shall not exceed 10 percent, and no individual value may be more than 12 percent.

4.2.6 The thickness swell test results from the originally unconditioned specimens (as manufactured) shall be used to adjust quality control test results to the qualification level.

4.2.7 When the moisture content of the unconditioned specimens is not greater than the typical moisture content of the rim board material in the referenced conditions per Section 4.2.1, testing for conditioned specimens is not required. In this case, the criteria given in Section 4.2.5 are applicable using the unconditioned specimens.

4.3 Lateral Edge Nailing Durability:

4.3.1 The lateral edge nailing durability for a specific rim board product shall be determined in accordance with the methods given in this section.

4.3.2 A minimum of three replications of each combination of rim board species and thickness, and at maximum depth, shall be tested. The dimension of rim board specimens shall meet the requirements given in Table 1.

4.3.3 The full-size rim board specimens shall be conditioned in accordance with either Section 104 of ASTM D 1037 (24-hour water soak) or an equivalent conditioning method.

4.3.4 A minimum of three rim board assemblies shall be fabricated in accordance with Sections 3.4.1.1 through 3.4.1.7, while the rim board specimen is still wet.

4.3.5 The rim board shall be redried to a moisture content between 8 and 12 percent.

4.3.6 For each rim board combination, the average ultimate lateral load transfer capacity, determined from the redried rim board assemblies, shall not be less than 75 percent of the average ultimate lateral load transfer capacity determined in accordance with Section 3.4. The 0.75 performance factor for durability is a go/no go criteria.

5.0 NOTCHES AND HOLES

Any notches or holes allowed per the manufacturer's literature and/or installation instructions shall be justified by calculations or tests.

6.0 FIRE BLOCKING

To qualify as fire blocking, equivalency to materials specified in IBC Section 717.2, IRC Section R602.8.1, or UBC Section 708.2, as applicable, shall be established.

7.0 QUALITY CONTROL

7.1 General: The rim board products shall be manufactured under an approved quality control program with inspections by an inspection agency accredited by the International Accreditation Service (IAS) or otherwise acceptable to ICC-ES.

7.1.1 Quality documentation complying with the ICC-ES Acceptance Criteria for Quality Documentation (AC10) shall be submitted.

7.1.2 Quality control shall comply with Sections 8.9 and 10 of ASTM D 5456, or Sections 8 and 9 (whichever is applicable) of ASTM D 5055, or an equivalent program.

7.2 Quality Assurance Testing:

7.2.1 Test equipment shall be properly maintained, calibrated and evaluated for accuracy and adequacy at a frequency satisfactory to the qualified agency.

7.2.2 The following shall be considered to be the scope of a minimum quality assurance testing program:

7.2.2.1 The thickness swell test described in Section 4.2 shall be used for quality assurance of thickness swell.

7.2.2.2 Moisture content and relevant specific gravity data shall be determined at a frequency that provides a representative sample of production.

7.2.2.3 Test frequency for all tests shall be chosen to yield quality assurance performance that is consistent with design values assigned to the product and its intended use.

7.3 Process Control:

ACCEPTANCE CRITERIA FOR RIM BOARD PRODUCTS (AC124)

7.3.1 Data from the tests outlined in Section 7.3 shall be evaluated prior to shipment of the material represented by the sample. Analytical procedures shall determine if material properties are in statistical control. The control level selected shall be consistent with current design capacities.

7.3.2 When the analysis described in Section 7.3.1 indicates that the product is below the control level, the associated portion of production shall be subject to re-examination in accordance with the acceptance procedures of Section 9 in ASTM D 5456, or Section 9 in ASTM D 5055, whichever is applicable.

8.0 EVALUATION REPORT RECOGNITION

8.1 The evaluation report shall include the recognized end uses of the rim board similar to what is described in Section 1.2.2 of this criteria.

8.2 The evaluation report shall specify the thickness, maximum depth, maximum vertical load capacity

(distributed and concentrated), and lateral load capacity of the rim board product.

8.3 The evaluation report shall include the following statement for rim boards tested in accordance with Section 3.4 and having a lateral load capacity greater than 150 plf (2189 N/m): “Toe nailed connections are not limited by the 150 plf (2189 N/m) lateral load capacity noted for Seismic Zones 3 and 4 in Section 2318.3.1 of the UBC, or Seismic Design Categories D, E, and F in Section 2305.1.4 of the IBC.”■

TABLE 1—LIMITATIONS ON RIM BOARD PRODUCTS

THICKNESS OF RIM BOARD ¹ (inches)	VERTICAL LOAD TRANSFER CAPACITY ²	LATERAL LOAD TRANSFER CAPACITY	
		Conventional Construction Applications ³	Engineered Applications ⁴
1.0	Minimum 2,000 plf established per Section 3.2	Minimum test capacity of 180 plf established per Section 3.4	Maximum allowable capacity is limited to 190 plf and shall be verified by testing in accordance with Section 3.4.
1.125			Maximum allowable capacity is limited to 220 plf and shall be verified by testing in accordance with Section 3.4.
1.25 and greater			Maximum allowable capacity is the test value established per Section 3.4.

For **SI**: 1 inch = 25.4 mm.

¹For the purposes of this table, the thickness of prefabricated wood I-joint rim board is the flange width.

²For all thicknesses of rim board material, allowable uniform vertical load transfer capacity shall exceed 2,000 plf (29 200 N/m).

³For all thicknesses of rim board material, the lateral load transfer capacity from tests conducted in accordance with Section 3.4 of this criteria shall meet or exceed 180 plf (2628 N/m). Rim board meeting this minimum 180 plf (2628 N/m) requirement shall be recognized in an evaluation report as being permitted for use in structures complying with conventional construction requirements as defined in IBC Section 2308, BNBC Section 2305.0, SBC Section 2301.1.2, and Section UBC Section 2320, and with light-framed construction requirements as defined in IRC Section 301. Refer to Appendix A.

⁴When the evaluation report recognizes an allowable lateral load transfer capacity for engineered applications, the maximum assigned allowable lateral load capacity established by qualification tests (see Section 3.4) shall be limited to 190 plf (2774 N/m) for the 1-inch-thick (25.4 mm) rim board products, and 220 plf (3212 N/m) for the 1.125-inch-thick (31.7 mm) rim board products. Allowable capacity for 1.25-inch-thick (31.7 mm) rim board products shall be assigned the value established by qualification testing per Section 3.4. For rim board products having a thickness between 1 inch (25.4 mm) and 1.25 inches (38 mm), the allowable capacity shall be interpolated between the following values:

1.0 in. (25.4 mm)	190 plf (2774 N/m)
1.125 in. (31.7 mm)	220 plf (3212 N/m)
1.25 in. (38 mm)	240 plf (3504 N/m)

The 240 plf (3504 N/m) capacity for 1.25-inch-thick (38 mm) rim board is added in this category for interpolation purposes only. In all cases, the allowable lateral load transfer capacity shall be verified by qualification testing in accordance with Section 3.4 of this criteria.

ACCEPTANCE CRITERIA FOR RIM BOARD PRODUCTS (AC124)

TABLE 2—TEST ASSEMBLY MATERIAL DIMENSIONS

TEST SPECIMEN	THICKNESS	DEPTH OR WIDTH	LENGTH
Rim board	See Section 1.4	See Section 3.4.1.1	Minimum 36 inches
I-joist ¹	Maximum 1 ³ / ₄ inches	Minimum 9 ¹ / ₄ inches	12 inches
Sheathing	Minimum ⁷ / ₁₆ -inch OSB	12 inches	Minimum 39 inches
Sill plate (SPF)	Nominal 2 inches	Nominal 4 inches	Minimum 39 inches

For **SI**: 1 inch = 25.4 mm.

¹Part of assembly construction (not rim board).

TABLE 3—NAILING SCHEDULE (NAILING USING BOX NAILS)¹

SHEATHING TO RIM BOARD OR JOIST	RIM BOARD TO SILL PLATES (Toe Nail)	JOIST TO SILL PLATE (Slanted)	RIM BOARD TO JOIST
8d at 6 inches on center	8d at 6 inches on center	2-8d	2-8d

For **SI**: 1 inch = 25.4 mm.

¹Alternative nailing schedules may be permitted.

APPENDIX A

Section 3.1.1 is intended to adjust engineered lumber products being used in rim board applications from laboratory test conditions to typical field conditions found in conventional wood-framed construction and engineered applications.

For rectangular rim board products that are 1.25 inches thick, ICC-ES considers these boards to have sufficient thickness for consistent nailing, since the lower range of acceptable rim board product is equivalent to the lower range of the de facto standard (solid-sawn lumber). Rim boards with a thickness less than 1.25 inches need to have their test load capacity adjusted per Section 3.4.3 to account for the increased difficulty of achieving proper nailing in the field.

The tested load capacity of the rim board product shall exceed 180 plf to qualify for use in structures meeting conventional construction requirements of the applicable code. For rim board products recognized for engineered applications, the allowable lateral load transfer capacity cannot exceed the values noted in footnote 4 to Table 1. The limitations are included to account for the reduced nail edge distance that occurs as the thickness is progressively reduced.

ACCEPTANCE CRITERIA FOR RIM BOARD PRODUCTS (AC124)

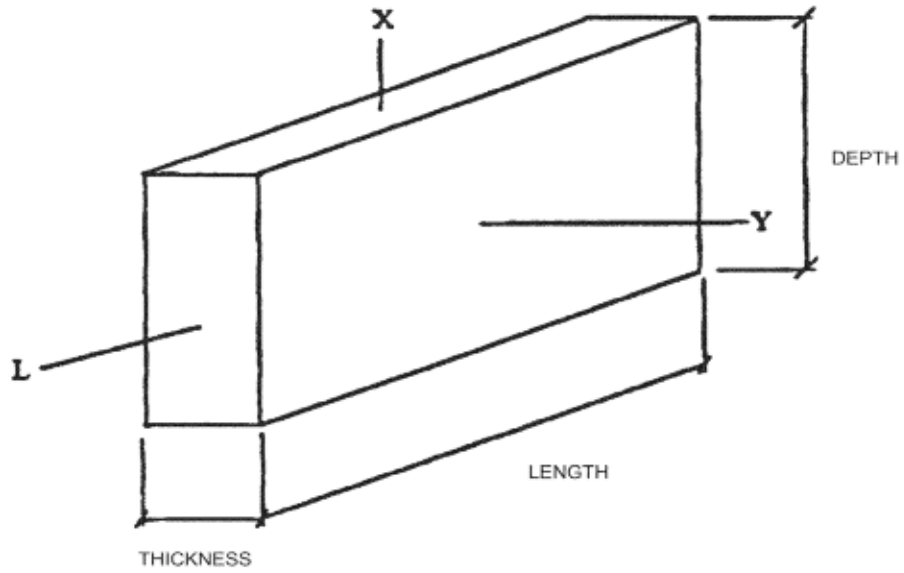

FIGURE 1—RIMBOARD ORIENTATION

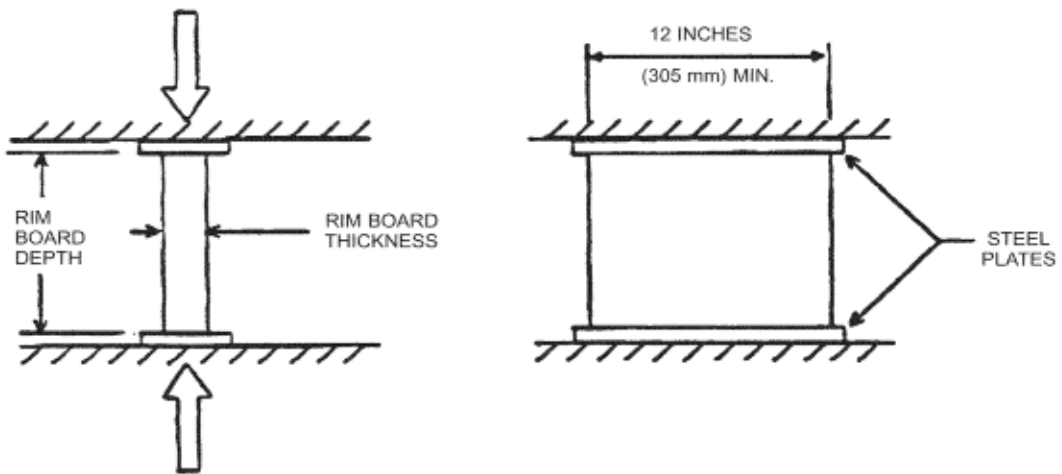

FIGURE 2—VERTICAL LOAD TRANSFER CAPACITY TEST

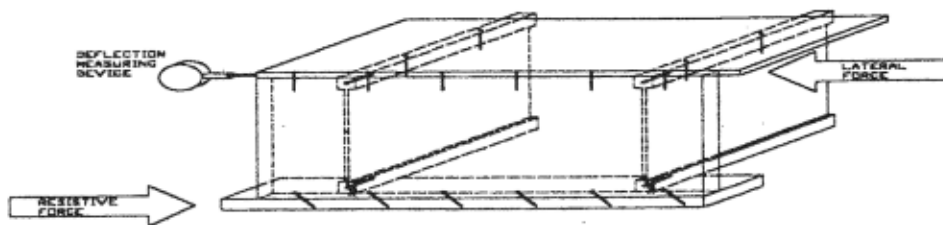

FIGURE 3—LATERAL LOAD CAPACITY TEST