

ACCEPTANCE CRITERIA FOR RACKING SHEAR EVALUATION OF PROPRIETARY SHEATHING MATERIALS ATTACHED TO LIGHT-FRAME WALL CONSTRUCTION OR CODE-COMPLYING SHEATHING ATTACHED TO LIGHT-FRAMED WALLS WITH PROPRIETARY FASTENERS

AC269

Approved October 2009

Effective November 1, 2009

Previously approved February 2009, June 2007, October 2006,
February 2006, October 2005

PREFACE

Evaluation reports issued by ICC Evaluation Service, Inc. (ICC-ES), are based upon performance features of the International family of codes and other widely adopted code families, including the Uniform Codes, the BOCA National Codes, and the SBCCI Standard Codes. Section 104.11 of the *International Building Code*® reads as follows:

The provisions of this code are not intended to prevent the installation of any materials or to prohibit any design or method of construction not specifically prescribed by this code, provided that any such alternative has been approved. An alternative material, design or method of construction shall be approved where the building official finds that the proposed design is satisfactory and complies with the intent of the provisions of this code, and that the material, method or work offered is, for the purpose intended, at least the equivalent of that prescribed in this code in quality, strength, effectiveness, fire resistance, durability and safety.

Similar provisions are contained in the Uniform Codes, the National Codes, and the Standard Codes.

This acceptance criteria has been issued to provide all interested parties with guidelines for demonstrating compliance with performance features of the applicable code(s) referenced in the acceptance criteria. The criteria was developed and adopted following public hearings conducted by the ICC-ES Evaluation Committee, and is effective on the date shown above. All reports issued or reissued on or after the effective date must comply with this criteria, while reports issued prior to this date may be in compliance with this criteria or with the previous edition. If the criteria is an updated version from the previous edition, a solid vertical line (|) in the margin within the criteria indicates a technical change, addition, or deletion from the previous edition. A deletion indicator (→) is provided in the margin where a paragraph has been deleted if the deletion involved a technical change. This criteria may be further revised as the need dictates.

ICC-ES may consider alternate criteria, provided the report applicant submits valid data demonstrating that the alternate criteria are at least equivalent to the criteria set forth in this document, and otherwise demonstrate compliance with the performance features of the codes. Notwithstanding that a product, material, or type or method of construction meets the requirements of the criteria set forth in this document, or that it can be demonstrated that valid alternate criteria are equivalent to the criteria in this document and otherwise demonstrate compliance with the performance features of the codes, ICC-ES retains the right to refuse to issue or renew an evaluation report, if the product, material, or type or method of construction is such that either unusual care with its installation or use must be exercised for satisfactory performance, or if malfunctioning is apt to cause unreasonable property damage or personal injury or sickness relative to the benefits to be achieved by the use of the product, material, or type or method of construction.

Acceptance criteria are developed for use solely by ICC-ES for purpose of issuing ICC-ES evaluation reports.

ACCEPTANCE CRITERIA FOR RACKING SHEAR EVALUATION OF PROPRIETARY SHEATHING MATERIALS ATTACHED TO LIGHT-FRAME WALL CONSTRUCTION OR CODE-COMPLYING SHEATHING ATTACHED TO LIGHT-FRAMED WALLS WITH PROPRIETARY FASTENERS (AC269)

1.0 INTRODUCTION

1.1 Purpose: The purpose of this criteria is to establish requirements for racking shear evaluation of proprietary sheathing materials attached to light-frame wall construction, or code-complying sheathing attached to light-framed walls with proprietary fasteners, used as lateral force resisting elements, that are to be recognized in an ICC Evaluation Service, Inc. (ICC-ES), evaluation report under the 2006 *International Building Code*[®] (IBC), the 2006 *International Residential Code*[®] (IRC), and the 1997 *Uniform Building Code*[™] (UBC). Bases of recognition are IBC Section 104.1.1, IRC Section R104.11, and UBC Section 104.2.8.

The reason for the development of this criteria is to allow evaluation of proprietary sheathing materials or alternative fasteners for code-complying sheathing for racking resistance, since the proprietary sheathing materials and code complying sheathing with proprietary fasteners are not listed for use as shear walls under Section 2306.4 of the IBC, or Section R602.10.3 of the IRC, or Sections 2315.3.3 and 2319.2 of the UBC.

1.2 Scope: This criteria is applicable to racking shear evaluation of proprietary sheathing materials attached to wood or steel framed walls, or code-complying sheathing materials attached to wood or steel framed walls with proprietary fasteners, used as lateral force resisting elements or braced wall panels on buildings of Type V construction. This criteria is applicable to shearwalls with the sheathing mechanically attached to the wall framing. The proprietary wall panels shall be qualified by conducting racking shear load tests of the proprietary wall panels with the sheathing attached to one side only as described in Section 4.0. Qualification by this method limits the proprietary wall panel use to sizes and materials used in the tests. The evaluation of sheathing materials for properties other than racking shear shall be as required by ICC-ES acceptance criteria for the proprietary sheathing or for code-complying sheathing material installed with proprietary installation details.

The scope of this criteria is limited to the evaluation of the proprietary wall panels used as shearwalls in the Seismic Design Categories noted in the appropriate section of this criteria.

1.3 Codes and Referenced Standards: Where standards are referenced in this criteria, the standards shall be applied consistently with the code upon which compliance is based.

1.3.1 2006 *International Building Code*[®] (IBC), International Code Council.

1.3.2 2006 *International Residential Code*[®] (IRC), International Code Council.

1.3.3 1997 *Uniform Building Code*[™] (UBC).

1.3.4 ASTM E 72-02, Standard Test Method of Conducting Strength Tests of Panels for Building Construction, ASTM International.

1.3.5 ASTM E 564-00e1, Standard Practice for Static Load Test for Shear Resistance of Framed Walls for Buildings, ASTM International.

1.3.6 *Standard Method of Cyclic (Reversed) Test for Shear Resistance of Framed Walls for Buildings*, by the Structural Engineers Association of Southern California (SEAOSC), dated August 1, 1996 (revised January 20, 1997).

1.3.7 AISI PM—2001, Standard for Cold-formed Steel Framing-Prescriptive Method for One- and Two-Family Dwellings, including 2004 Supplement, American Iron and Steel Institute.

1.3.8 AISI NAS General-04, Standard for Cold-Formed Steel Framing-General Provisions, American Iron and Steel Institute.

1.3.9 ASCE 16-95, Standard for Load and Resistance Factor Design (LRFD) for Engineered Wood Construction, American Society of Civil Engineers.

1.3.10 ANSI/AF&PA NDS-2005, National Design Specification (NDS) for Wood Construction, American Forest & Paper Association.

1.3.11 ICC-ES Acceptance Criteria for Nails and Spikes (AC116).

1.3.12 ICC-ES Acceptance Criteria for Prefabricated Wood Shear Panels (AC130).

1.3.13 ICC-ES Acceptance Criteria for Wood-based Studs (AC202).

1.4 Definitions:

1.4.1 Aspect Ratio: The height divided by the length of the shearwall. Also refer to Section R202 of the IRC.

1.4.2 Braced Wall Line: A single or series of proprietary wall panels aligned in a single story.

1.4.3 Braced Wall Panel: A section of wall braced in accordance with IBC Section 2308.9.3 or 2308.12.4; or IRC Section R602.10 for wood framing or Section R603.7 or Section R301.1.1 for cold-formed steel framing, which extends the full height of the wall.

1.4.4 Proprietary Wall Panel: A section of wall jobsite-constructed with the proprietary sheathing material, or code-complying sheathing attached to the wall framing with a proprietary fasteners designed to resist in-plane shear loads through interaction of framing members, sheathing material, and anchors.

1.4.5 Proprietary Sheathing Material: A wall sheathing material evaluated under both this and another appropriate ICC-ES acceptance criteria.

1.4.6 Code-Complying Sheathing Material: A wall sheathing material for which the applicable code includes specifications (for example, oriented strand board is required by IBC Section 2303.1.4 to comply with DOC PS2).

1.4.7 Continuously Sheathed Wall: A wall with the proprietary sheathing material applied at all sheathable

ACCEPTANCE CRITERIA FOR RACKING SHEAR EVALUATION OF PROPRIETARY SHEATHING MATERIALS ATTACHED TO LIGHT-FRAME WALL CONSTRUCTION OR CODE-COMPLYING SHEATHING ATTACHED TO LIGHT-FRAMED WALLS WITH PROPRIETARY FASTENERS (AC269)

areas of all exterior walls, and interior wall lines, where required, including areas above and below openings.

1.4.8 Light-frame Wall Construction: See the definition of light-frame construction in IBC Section 202.

2.0 BASIC INFORMATION

2.1 General: The following information shall be submitted:

2.1.1 Product Description: Complete information concerning material specifications, thickness, size and the manufacturing process of the proprietary sheathing and proprietary fasteners.

2.1.2 Installation Instructions: Installation details and limitations, fastener materials, and installation manual.

2.1.3 Packaging and Identification: A description of the method of packaging and field identification of the proprietary sheathing or proprietary fasteners. Identification provisions must include the evaluation report number and the name or logo of the inspection agency. The identification shall be visible after the sheathing material is installed.

2.1.4 Field Preparation: A description of the methods of field-cutting, application and finishing.

2.2 Testing Laboratories: Testing laboratories shall comply with Section 2.0 of the ICC-ES Acceptance Criteria for Test Reports (AC85) and Section 4.2 of the ICC-ES Rules of Procedure for Evaluation Reports.

2.3 Test Reports: Test reports shall comply with AC85.

2.4 Product Sampling: Products shall be sampled in accordance with Section 3.1 of AC85.

3.0 TEST AND PERFORMANCE REQUIREMENTS

3.1 The proprietary wall panels shall be tested in accordance with Section 4.0 and the description of the tested proprietary wall panels shall include the following:

3.1.1 Dimensions: Thickness, height and length of each sheathing material type tested shall be listed in the test report.

3.1.2 Sheathing Material: A description of the sheathing material shall be included in the test report. The proprietary sheathing material shall comply with a current ICC-ES evaluation report. The code-complying sheathing material shall be clearly identified to determine compliance.

3.1.3 Panel Framing: The framing of the tested proprietary wall panels, consisting of either wood or steel shall be described in the test report. The description of wood framing shall include dimensions, species, grade and specific gravity. The description of steel framing shall include dimensions (including base-metal thickness), mechanical properties, and detailed description of holes and notches. Framing members of wood shall have at least a nominal 2-inch (50.8 mm) width. Framing members of cold-formed steel shall be $1\frac{5}{8}$ inches by $3\frac{1}{2}$ inches (41.28 mm by 88.90 mm), with a $\frac{3}{8}$ -inch (9.53 mm) return lip. For qualification testing under Section 4.2, the cold-formed steel shall have a maximum base metal thickness of 0.0329 inch (0.84 mm). Grading standards and specifications described in the applicable code shall apply

to the all-sawn-lumber framing members and cold-formed steel framing members. Proprietary wood-based framing members, such as structural composite lumber complying with the ICC-ES Acceptance Criteria for Wood-based Studs (AC202), shall be recognized in a current ICC-ES evaluation report.

3.1.4 Connections: The sheathing-to-framing connection details shall be described in the test report. Fasteners shall be properly specified, including fastener type, size, length and location. Proprietary wall panels shall be constructed with fasteners complying with the code. Where no fastener values are recognized by the applicable code, data described in the ICC-ES Acceptance Criteria for Nails and Spikes (AC116) or a current ICC-ES acceptance criteria for the fasteners is required. When used, independent hold-down devices shall be currently recognized in an ICC-ES evaluation report or shall comply with the Acceptance Criteria for Hold-downs (Tie-downs) Attached To Wood Members (AC155) or current ICC-ES acceptance procedures for steel framed wall hold-downs. Results of the hold-down tests shall be used in the analysis of the wall panel. Fastener spacing shall not exceed 12 inches (304.8 mm) along intermediate framing members and 6 inches (152.4 mm) along edge framing members. For wood framing, fasteners used to attach the sheathing to the framing shall be placed not less than $\frac{3}{8}$ inch (9.53 mm) in from the edge of the framing member. For steel framing, the fastener to framing edge distance shall be not less than 1.5 times the fastener diameter from the center of the fastener to the nearest edge of the formed steel. Connections and anchorages shall be detailed or adequately described for the attachment of the wall panel to the other building elements.

3.1.5 Holes and Notches in Framing Members:

3.1.5.1 Wood Framing Members: Holes and notches may be installed in the framing at predetermined locations only. Testing shall include the appropriate size and locations of the hole(s) and notch(es) as intended for the end use. Holes are not permitted to be greater in diameter than 40 percent of the framing member width, and notches are not to be greater than 25 percent of the framing member width.

3.1.5.2 Steel Framing Members: Holes and notches may be installed in the framing members at predetermined locations only. Holes and notches shall be limited based on the tested assemblies and shall not be greater than allowed by AISI General -04 and AISI PM—2001 Section A4.4.

3.1.6 Sheathing Penetrations and Joints:

3.1.6.1 Penetrations in Sheathing Material: Penetrations in the sheathing material will be permitted only at predetermined locations. Testing shall include the appropriate size and location of hole(s) and notch(es) as intended for end use. The ICC-ES evaluation report shall state the limitations for hole and notch sizes and locations ascertained by testing.

3.1.6.2 Sheathing Material Joints: The joints in sheathing materials shall occur over framing members or shall be blocked and attached to the framing member and blocking. Sheathing materials tested with horizontal joints unblocked may be listed for this method of installation in the evaluation report.

ACCEPTANCE CRITERIA FOR RACKING SHEAR EVALUATION OF PROPRIETARY SHEATHING MATERIALS ATTACHED TO LIGHT-FRAME WALL CONSTRUCTION OR CODE-COMPLYING SHEATHING ATTACHED TO LIGHT-FRAMED WALLS WITH PROPRIETARY FASTENERS (AC269)

3.2 Proprietary Wall Panel Aspect Ratios: The maximum aspect ratio for the proprietary wall panel shall be determined by testing under Section 4.0. The aspect ratio shall be reported in the ICC-ES evaluation report and shall not exceed 2:1.

3.3 Alternates to IRC Wall Bracing Methods:

3.3.1 Braced Wall Panels: Proprietary wood frame wall panels tested under Section 4.1 that develop allowable shear resistance equal to or greater than that for a specific wall bracing method listed in Table 1 of this criteria shall be considered an alternate to the braced wall panel for the specific method(s) evaluated. Qualification under this criteria section does not include use under IRC Section R602.10.5.

3.3.2 Alternate to IRC Section R602.10.5, Continuous Structural Panel Sheathing for Seismic Design Categories A, B and C: The continuously sheathed wall lines tested in accordance with Section 4.2 shall develop racking stiffness and ultimate load capacity equal to or greater than the predicted values. The evaluated sheathing material shall be compared to Method 3, braced wall panel construction, described in Section R602.10.3 of the IRC for wall bracing applications permitted by Section R602.10.5 of the IRC with the allowable shear resistance listed in Table 1 of this criteria. Wall panel aspect ratios for the evaluated proprietary sheathing shall not exceed those tested under Section 4.2. Continuously sheathed wall constructed with the proprietary sheathing material shall satisfy the wall bracing amounts from Table R602.10.1 of the IRC for the appropriate bracing method as qualified under Section R602.10.5 of the IRC.

3.4 Shearwalls Under the IBC and UBC: If recognition is requested for the seismic conditions noted in Section 4.3 in this criteria, the final allowable shear to be noted in the evaluation report must be the lesser of the values determined in accordance with Section 4.4.1 and Section 4.4.2 in this criteria.

3.5 Design Loads: When proprietary wall panels tested and evaluated under this criteria are used under the IBC and the UBC, design load on the building shall be determined in accordance with Chapter 16 of the IBC and the UBC, as applicable, and the shear loads shall be resisted by the proprietary wall panels using the allowable load determined by Section 4.4 of this criteria.

3.6 Commercial Hold-downs: When commercial hold-downs are required to achieve specified shear loads that are to be reported in the proposed evaluation report, the hold-downs shall be evaluated as noted in Section 3.1.4 of this criteria. The shear wall assemblies described in the evaluation report must include a reference to the commercial hold-down and the appropriate ICC-ES evaluation report on the hold-down.

3.7 Proprietary Wall Panel Structural Testing Other than Racking: Structural tests other than the racking test are beyond the scope of this acceptance criteria. Structural analysis in accordance with the appropriate code or testing in accordance with the appropriate ICC-ES criteria is required, to derive other required structural properties.

4.0 PROPRIETARY WALL PANEL LOAD TEST METHODS

4.1 Proprietary Wall Panels Subjected to Racking for Wind and/or Seismic Design Categories A, B and C for Wood Construction and A and B for Steel Construction under the IBC and IRC and Seismic Zones 0, 1 and 2 under the UBC for Both Steel and Wood Construction:

4.1.1 Purpose: Proprietary wall panels shall be tested for racking shear in accordance with ASTM E 72, Section 14 (Racking Load—Evaluation of Sheathing Material on a Standard Wood Frame) and/or Section 15 (Racking Load—Evaluation of Sheathing Material (Wet) on a Standard Wood Frame) as specified in Section 4.1.7 of this criteria.

4.1.2 Proprietary Wall Panel Framing: The tested wall panel construction shall be in accordance with Sections 3.1 and 3.2 in this criteria. When wood framing is used, Douglas fir or southern pine lumber with a moisture content of 15 percent or less shall be used. The tests shall be conducted with the ASTM E 72 specified hold-down rods in place.

4.1.3 Loading Beam: The loading beam shall not be in contact with the sheathing material and shall not interfere with the movement of the sheathing material during the test procedure.

4.1.4 Loading Procedure: Loading procedure from ASTM E 72 shall be followed, except that the specimen shall be allowed to recover for 5 minutes after the load is removed following the first and second loading stages.

4.1.5 Compressive Deformation: An additional sensor shall be installed at the right lower corner of the specimen (Figure 7 of ASTM E 72) to measure bottom plate compressive deformation and the displacement of the wall stud relative to the base of the test fixture.

4.1.6 Horizontal Displacement: Horizontal displacement, used to establish the allowable shear, shall be calculated by removing the bottom plate uplift, bottom plate compressive deformation, and base slip (bottom plate slip) from the total wall deflection measured at the top of the specimen (top plate horizontal displacement), accounting for the tested aspect ratio.

4.1.7 Conditioning: The proprietary wall panels shall be tested in accordance with ASTM E 72, Section 15, unless the construction is limited to locations where the proprietary wall panel will not be subjected to wetting during construction. Wall panels, where the sheathing material is the water-resistive barrier, shall be tested in accordance with ASTM E 72, Section 15. The specimen may be allowed to air dry in accordance with the test standard, prior to testing, if the sheathing material is to be covered by an approved exterior wall covering. For sheathing not subjected to wetting during construction or in-service, the proprietary wall panels may be tested under ASTM E 72, Section 14.

4.1.8 Determination of Aspect Ratio of the Test Assembly: The aspect ratio for the sheathing material shall be determined by calculating the aspect ratio of the sheathed portion of the wall test assembly.

ACCEPTANCE CRITERIA FOR RACKING SHEAR EVALUATION OF PROPRIETARY SHEATHING MATERIALS ATTACHED TO LIGHT-FRAME WALL CONSTRUCTION OR CODE-COMPLYING SHEATHING ATTACHED TO LIGHT-FRAMED WALLS WITH PROPRIETARY FASTENERS (AC269)

4.2 Continuously Sheathed Wall Subjected to Racking for Wind and/or Seismic Design Categories A, B, and C for Wood Construction under the IRC:

4.2.1 Purpose: The testing described in this section shall be used to document use of a continuously sheathed wall for proprietary sheathing materials applied to wood stud walls in accordance with the IRC, as noted in Section 3.3.2 of this criteria.

4.2.2 Test Method: Continuously sheathed walls shall be tested for racking shear in accordance with the test procedure of ASTM E 564 to evaluate the conformance of the sheathing materials with Section R602.10.5 of the IRC. All of the configurations shown in Table 2 shall be tested.

Conditions of Acceptance: The measured test results for stiffness and ultimate strength shall be equal to or greater than the predicted values for the sheathing material using the reduction factors noted in Table 2. The predicted values for stiffness and ultimate strength are determined using Footnotes 1 and 2 of Table 2.

4.2.3 Loading Procedure: A displacement-controlled ramp function shall be permitted in lieu of the loading procedure of ASTM E 564 when an electronic data acquisition system is used. The maximum load shall be achieved in no less than five minutes and no more than twenty minutes.

4.2.4 Overturning Restraints: The ASTM E 564 requirements may be used for wood framing. Overturning restraints shall be provided at the wall line ends using corner returns framed in accordance with Figure R602.10.5 of the IRC, or prefabricated metal hold-down devices, as specified in Table 2.

4.2.5 Specimen Configuration and Sample Size: An 8-foot-by-8-foot (2.4 m by 2.4 m) specimen shall be tested with prefabricated hold-downs to establish the unit racking stiffness and unit shear (configuration 1 in Table 2). Two 8-foot-high-by-12-foot-wide (2.4 m by 3.6 m) specimens shall be tested with a 2-foot (0.6 m) and a 4-foot (1.2 m) corner (configurations 2 and 3 in Table 2, respectively). A minimum of six wall line configurations with openings shall be tested in accordance with configurations 4 to 9 in Table 2. Each configuration with openings shall be a minimum of 12 feet (3.60 m) long and shall have a minimum of one opening. Each opening shall be a minimum of 4 feet wide. Wall panels shall have the minimum length permitted by IRC Table R602.10.5 based on the adjacent openings. Each opening height included in IRC Table R602.10.5 (i.e., 100%, 85%, and 65% of wall height) shall be incorporated in at least one specimen configuration. Different wall heights need not be evaluated. Configuration 1 (Table 2) shall have a minimum sample size in accordance with ASTM E 564. Configurations 2 to 9 (Table 2) shall be permitted to have a minimum sample size of one wall specimen for each configuration.

4.2.6 Boundary Conditions: Pretension force on anchor bolts and hold-down devices shall not exceed 1,200 pounds (5 400 N). The loading beam shall have a bending stiffness capacity, EI , of no more than 330,000 kip-in² (e.g. 29,000 ksi × 11.3 in⁴). Additional gravity load shall not be applied to the specimens or testing fixtures. Anchor bolt size, spacing, and location shall be in

accordance with the applicable building code requirements (also refer to Section 6.1.5). A minimum of two anchor bolts shall be used for every continuous bottom plate section, except that one bolt shall be used for the 24-inch (610 mm) corner segment in Configuration 2.

4.2.6.1 Boundary Conditions for Configurations 2 and 3: For Configurations 2 and 3, for the purpose of conducting the tests, anchor bolts shall be permitted to be spaced at 24 inches on center (610 mm), and 3-inch-by-3-inch-by-¹/₄-inch-thick (76 mm by 76 mm by 6.35 mm thick) square plate washers shall be permitted to be installed between the wood bottom plate and the nut. An anchor bolt shall be located not more than 13 inches (330 mm) nor less than 11 inches (279 mm) from each end of the braced wall segment and the corner segment.

4.2.7 Amount of Sheathing Along a Braced Wall Line—Percent of Full-Height Sheathed Wall Required, Table R602.10.1 of the IRC: Testing of one additional wall configuration 8 from Table 2 is required to verify the increase in percentage of full-height wall sheathing required for Methods 2,4,5,6,7 or 8 as noted in Table R602.10.1 of the IRC. The test wall shall be modified to include additional percentage of sheathing (alternate to either Methods 2, 4, 5, 6, 7 or 8) as required in Table R602.10.1 of the IRC and shall be tested as noted in Sections 4.2.2 to 4.2.6.

Conditions of Acceptance: The actual test results (design load according to Section 4.4 of this criteria, and deformation at design load) shall be compared to the predicted results based on equivalency to Method 3 wall configuration 8 as determined using Section 2305.3.8.2 of the IBC. The actual value shall be equal to or greater than the predicted value for the Method 3 configuration 8 wall assembly to qualify for prescriptive design in accordance with the IRC.

Exception: Testing of Configuration 8 wall with additional percentage of proprietary sheathing shall not be required if the Configuration 8 value for design load and deformation at design load meets the conditions of acceptance.

4.3 Proprietary Wall Panels Subjected to Racking for Wind and/or Seismic Design Categories C, D, D0, D1, and D2 for Steel Construction and D, D0, D1, and D2, for Wood Construction under the IBC and IRC and Seismic Zones 3 and 4 under the UBC:

4.3.1 Purpose: Testing in accordance with Section 4.1 shall be conducted prior to testing in accordance with this section. Proprietary wall panels shall be tested for cyclic shear in accordance with the *Standard Method of Cyclic (Reversed) Test for Shear Resistance of Framed Walls for Buildings*, by the Structural Engineers Association of Southern California (SEAOSC), dated August 1, 1996 (revised January 20, 1997), with the modifications to the SEAOSC document as noted in Section 5.1 of ICC-ES Acceptance Criteria for Prefabricated Wood Shear Panels (AC130).

4.3.2 Determination of Aspect Ratio of the Test Assembly: The aspect ratio for the sheathing material shall be determined by calculating the aspect ratio of the sheathed portion of the wall test assembly.

ACCEPTANCE CRITERIA FOR RACKING SHEAR EVALUATION OF PROPRIETARY SHEATHING MATERIALS ATTACHED TO LIGHT-FRAME WALL CONSTRUCTION OR CODE-COMPLYING SHEATHING ATTACHED TO LIGHT-FRAMED WALLS WITH PROPRIETARY FASTENERS (AC269)

4.4 Design Loads:

4.4.1 Design Racking Shear Loads Derived from Testing Under Section 4.1 of This Acceptance Criteria:

The design racking shear (pounds per foot or N/m) for the test samples shall be the lesser of the loads based on a drift limit or ultimate load limit, determined as follows:

4.4.1.1 Ultimate Load: For wood framed wall panels, the allowable stress design (ASD) allowable racking shear (pounds per foot or N/m) is the average ultimate load divided by a safety factor of 3 divided by the length of the wall panel. For cold-formed steel framed wall panels under allowable stress design (ASD), the allowable racking shear (pounds per foot) is the average ultimate load divided by a safety factor (Ω) of 2.5 divided by the length of the wall panel. For cold-formed steel framed wall panels under load and resistance factor design (LRFD), the available shear (pounds per foot) is the average ultimate load multiplied by a resistance factor (ϕ) of 0.55 divided by the length of the wall panel.

4.4.1.2 Drift Limit: The design racking shear (pounds per foot) is the applied average load in pounds (N) that causes a horizontal displacement of 0.2 inch (5.1 mm) divided by the length of the wall panel. The minimum applied average load at this displacement limit shall be 1,200 pounds (5 400 N).

4.4.2 Design Loads Derived from Testing Under Section 4.3 of this Acceptance Criteria: The design racking shear (pounds per foot or N/m) for the test sample shall be the lesser of the loads based on a drift limit or ultimate load limit, determined as noted in Section 5.1.3 or 5.1.4 of AC130, whichever is applicable; except for use of a safety factor of 3.0 for wood studs and 2.5 for steel studs. Drift limits shall be determined using a maximum deflection amplification factor, C_d , of 2.

5.0 QUALITY CONTROL

Quality control requirements shall be as noted in the ICC-ES acceptance criteria for the proprietary sheathing material. Quality control requirements for the code-complying sheathing shall be as required by the code.

6.0 EVALUATION REPORT RECOGNITION

6.1 Installation: The following is information that shall be included in the ICC-ES evaluation report for the sheathing:

6.1.1 Cutting of Proprietary Wall Panels: Statement that cutting the wall panels for wall openings is not permitted.

6.1.2 Holes and Notches in Framing Members:

6.1.2.1 Wood Framing Members: Holes and notches may be installed in the framing at predetermined locations only as noted in the evaluation report. The ICC-ES evaluation report shall state the limitations for hole and notch sizes and locations ascertained by testing.

6.1.2.2 Steel Framing Members: Holes and notches may be installed in the framing members at predetermined locations only as ascertained by testing and noted in the evaluation report.

6.1.3 Penetrations in Sheathing Materials: Penetrations in the sheathing material will be permitted only at predetermined locations as noted in the evaluation report. The ICC-ES evaluation report shall state the limitations for hole and notch sizes and locations ascertained by testing.

6.1.4 Aspect Ratios: The aspect ratio shall be reported in the ICC-ES evaluation report and shall not exceed 2:1.

6.1.5 The wall assemblies shall be detailed in the evaluation report based on the tested assemblies and shall be in accordance with the applicable code when using prescriptive design procedures.

6.2 Conditions of Use: The following Conditions of Use for proprietary wall panels installed under the IBC, IRC, and UBC shall be included in the evaluation report, as applicable:

6.2.1 Special inspection complying with Section 1704 of the IBC must be provided for structures assigned to Seismic Design Categories C and D. Special inspections in Seismic Design Categories C and D must be provided for nailing, bolting, anchoring and other fastening of components within the seismic-force-resisting system, including connections of the wall panels and braced wall lines to drag struts and hold-downs, in accordance with IBC Sections 1705.1, to 1705.3, 1707.1 and 1707.3. A statement of special inspections complying with IBC Section 1705 must be provided to the code official.

6.2.2 For the use of proprietary wall panels and braced wall lines in Exposure B where the basic wind speed is 120 mph or greater and in Exposures C and D where the basic wind speed is 110 mph or greater, special inspection must be provided in accordance with IBC Sections 1705.1, 1705.2 and 1705.4, except for buildings designed and constructed in accordance with IBC Section 2308 or the IRC. A statement of special inspections complying with IBC Section 1705 shall be provided to the code official. (This includes addressing requirements in IBC Sections 1705.4.1 and 1705.4.2.)

6.2.3 For proprietary sheathing materials and proprietary fasteners of code-complying sheathing tested to this criteria, earthquake load resistance shall be determined using the following maximum values: $R = 2$, $\Omega_o = 2.5$, $C_d = 2$ under the IBC with a maximum height of 35 feet (19.8 m) for Seismic Design Category D; and $R = 4.5$, $\Omega = 2.8$ under the UBC with a maximum height of 65 feet (19.8 m) for Seismic Zones 3 and 4. This criteria is not applicable to Seismic Design Categories E and F. ■

ACCEPTANCE CRITERIA FOR RACKING SHEAR EVALUATION OF PROPRIETARY SHEATHING MATERIALS ATTACHED TO LIGHT-FRAME WALL CONSTRUCTION OR CODE-COMPLYING SHEATHING ATTACHED TO LIGHT-FRAMED WALLS WITH PROPRIETARY FASTENERS (AC269)

TABLE 1—BRACED WALL PANEL CONSTRUCTION SHEAR RESISTANCE FOR THE INTERNATIONAL RESIDENTIAL CODE®

METHOD	MATERIAL	MINIMUM PANEL LENGTH (feet and inches)	ALLOWABLE SHEAR RESISTANCE (plf)	
			Framing Spacing (inches)	
			16	24
1	Nominal 1-by-4 continuous diagonal let-in brace	4'-7" for 8 ft. wall height 5'-9" for 10 ft. wall height	Note 2	Note 2
2	⁵ / ₈ -inch wood boards applied diagonally	4'-0"	Note 2	Note 2
3	Wood structural panel ³	4'-0"	200 ^{1,3}	230 ^{1,3}
4	¹ / ₂ -inch or ²⁵ / ₃₂ -inch structural fiberboard sheathing	4'-0"	125 ¹	Note 2
5	¹ / ₂ -inch gypsum wallboard	8'-0"	Note 2	125 ¹
6	Particleboard wall sheathing	4'-0"	120 ¹	Note 2
7	Portland cement plaster	4'-0"	180 ¹	Note 2
8	Hardboard panel siding	Entire wall	Note 2	Note 2

For **SI**: 1 inch = 25.4 mm, 1 foot = 0.3 m, 1 plf = 14.59 N/m.

¹Allowable shear resistance values are based on the IBC one-sided sheathed ASTM E 72 tests in the dry condition.

²Allowable shear resistance values not provided in the IBC shall be determined by testing in accordance with **Section 4.1** of this acceptance criteria (**dry condition only**). **The allowable shear values shall be determined in accordance with Section 4.4.1 of this criteria.** In no case shall the allowable shear resistance for this comparison be less than 150 plf (2 189 N/m).

³Allowable load for the 16-inch framing is based on ⁵/₁₆-inch-thick wood structural panels, and the 24-inch framing is based on the ³/₈-inch-thick wood structural panels.

ACCEPTANCE CRITERIA FOR RACKING SHEAR EVALUATION OF PROPRIETARY SHEATHING MATERIALS ATTACHED TO LIGHT-FRAME WALL CONSTRUCTION OR CODE-COMPLYING SHEATHING ATTACHED TO LIGHT-FRAMED WALLS WITH PROPRIETARY FASTENERS (AC269)

TABLE 2—TEST MATRIX FOR CONTINUOUSLY SHEATHED SHEAR WALLS FOR THE INTERNATIONAL RESIDENTIAL CODE®

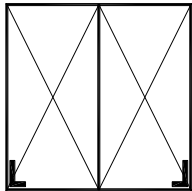
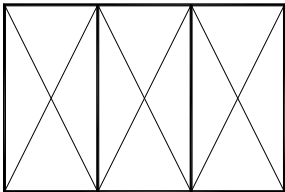
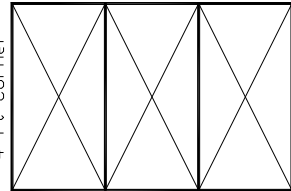
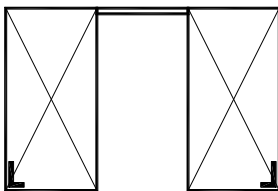
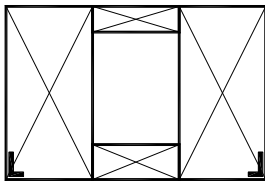
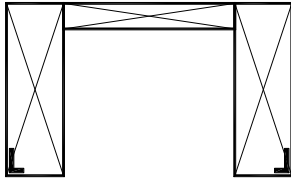
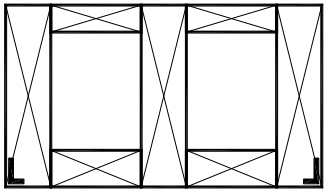
Config.	Sketch ^{3,4,5}	Size H x W, feet	Max Opening Height, %	Reduction Factor ^{1,2}	Type of Openings	Segment Aspect Ratio ⁶
1 ³		8x8	0%	1.0	None	1:1
2 ⁴	2-ft Corner 	8x12	0%	0.80	None	1:1.5
3 ⁴	4-ft Corner 	8x12	0%	0.90	None	1:1.5
4 ⁵		8x12	100%	0.40	Full height	2:1
5 ⁵		8x12	65%	0.51	Window	2:1
6 ⁵		8x13.3	85%	0.21	Door	3:1
7 ⁵		8x14	65%	0.28	2-Windows	4:1

ACCEPTANCE CRITERIA FOR RACKING SHEAR EVALUATION OF PROPRIETARY SHEATHING MATERIALS ATTACHED TO LIGHT-FRAME WALL CONSTRUCTION OR CODE-COMPLYING SHEATHING ATTACHED TO LIGHT-FRAMED WALLS WITH PROPRIETARY FASTENERS (AC269)

TABLE 2—TEST MATRIX FOR CONTINUOUSLY SHEATHED SHEAR WALLS FOR THE INTERNATIONAL RESIDENTIAL CODE® (Continued)

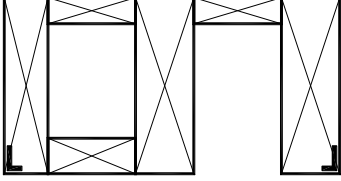
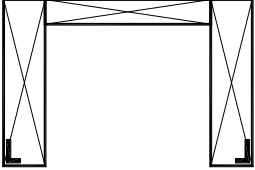
Config.	Sketch ^{3,4,5}	Size H x W, feet	Max Opening Height, %	Reduction Factor ^{1,2}	Type of Openings	Segment Aspect Ratio ⁶
8 ⁵		8x15.3	65%, 85%	0.29	Window and Door	4:1, 3:1
9 ⁵		8x12	85%	0.16	Garage Door	4:1

For SI: 1 foot = 0.3 m.

Footnotes:

1. The predicted racking stiffness for use with Section 3.3.2 shall be determined as the product of the reduction factor, the unit racking stiffness (from Configuration 1 specimen), and the wall length.
2. The predicted ultimate load capacity for use with Section 3.3.2 shall be determined as the product of the reduction factor, the unit shear (from Configuration 1 specimen), and the wall length.
3. Configuration 1 shall be tested with prefabricated metal holddown devices at each end of the wall.
4. Configurations 2 and 3 shall be tested with 2 foot (0.6 m) and 4 foot (1.20 m) respectively corner returns at each end of the wall and shall be detailed in accordance with Figure R602.10.5 of the IRC.
5. Configurations 4 through 9 shall be tested with prefabricated metal holddown devices at each end of the wall.
6. Segment Aspect Ratio is the aspect ratio for an individual full height panel, using an 8 foot high segment and the width of panel. Aspect Ratio is defined in Section R202 of the IRC.