



ICC Evaluation Service, Inc.
Birmingham Regional Office
900 Montclair Road, Suite A
Birmingham, AL 35213
tel: 205.599.9800
fax: 205.599.9850
www.icc-es.org

November 23, 2009

TO: PARTIES INTERESTED IN EVALUATION REPORTS ON ANCHORAGE TO CONCRETE

SUBJECT: Acceptance Criteria for Mechanical Anchors in Concrete Elements, Subject AC193-1009-R1 (BG/ME)

Dear Madam or Sir:

Enclosed is a copy of the subject revised acceptance criteria approved by the ICC-ES Evaluation Committee on November 1, 2009, effective immediately.

The approved revisions will permit reports to be issued in accordance with the 2009 or 2006 *International Building Code* and corrects some editorial errors.

Evaluation reports issued on or after the effective date noted above, and falling within the scope of this criteria, will be required to comply with the enclosed edition of the criteria. Evaluation reports issued prior to the effective date may be in compliance either with the enclosed acceptance criteria or with the previous edition. Evaluation reports based on a superseded version of an acceptance criteria must be brought into compliance with the most recent edition at the time the reports are reissued. Therefore, applicants should submit data verifying compliance at the time they apply for re-examination.

ICC-ES evaluation reports issued on or after the effective date noted above, both new reports and conversions of legacy reports, must comply with this criteria if they fall within its scope.

If you have any questions, please contact Brian Gerber, at (800) 423-6587, extension 3260. You may also reach us by e-mail at es@icc-es.org.

Yours very truly,

A handwritten signature in black ink that reads 'Gary G. Nichols'.

Gary Nichols, P.E.
Vice President

GN/jw:raf

Enclosure

cc: Evaluation Committee

ACCEPTANCE CRITERIA FOR MECHANICAL ANCHORS IN CONCRETE ELEMENTS

AC193

Approved November 2009

Effective November 1, 2009

Previously approved February 2009, May 2008, February 2008, December 2007, June 2007, October 2006, June 2006, October 2005, June 2005, February 2004, October 2003, June 2003, April 2002

PREFACE

Evaluation reports issued by ICC Evaluation Service, Inc. (ICC-ES), are based upon performance features of the International family of codes and other widely adopted code families, including the Uniform Codes, the BOCA National Codes, and the SBCCI Standard Codes. Section 104.11 of the *International Building Code*® reads as follows:

The provisions of this code are not intended to prevent the installation of any materials or to prohibit any design or method of construction not specifically prescribed by this code, provided that any such alternative has been approved. An alternative material, design or method of construction shall be approved where the building official finds that the proposed design is satisfactory and complies with the intent of the provisions of this code, and that the material, method or work offered is, for the purpose intended, at least the equivalent of that prescribed in this code in quality, strength, effectiveness, fire resistance, durability and safety.

Similar provisions are contained in the Uniform Codes, the National Codes, and the Standard Codes.

This acceptance criteria has been issued to provide all interested parties with guidelines for demonstrating compliance with performance features of the applicable code(s) referenced in the acceptance criteria. The criteria was developed and adopted following public hearings conducted by the ICC-ES Evaluation Committee, and is effective on the date shown above. All reports issued or reissued on or after the effective date must comply with this criteria, while reports issued prior to this date may be in compliance with this criteria or with the previous edition. If the criteria is an updated version from the previous edition, a solid vertical line (|) in the margin within the criteria indicates a technical change, addition, or deletion from the previous edition. A deletion indicator (→) is provided in the margin where a paragraph has been deleted if the deletion involved a technical change. This criteria may be further revised as the need dictates.

ICC-ES may consider alternate criteria, provided the report applicant submits valid data demonstrating that the alternate criteria are at least equivalent to the criteria set forth in this document, and otherwise demonstrate compliance with the performance features of the codes. Notwithstanding that a product, material, or type or method of construction meets the requirements of the criteria set forth in this document, or that it can be demonstrated that valid alternate criteria are equivalent to the criteria in this document and otherwise demonstrate compliance with the performance features of the codes, ICC-ES retains the right to refuse to issue or renew an evaluation report, if the product, material, or type or method of construction is such that either unusual care with its installation or use must be exercised for satisfactory performance, or if malfunctioning is apt to cause unreasonable property damage or personal injury or sickness relative to the benefits to be achieved by the use of the product, material, or type or method of construction.

Acceptance criteria are developed for use solely by ICC-ES for purposes of issuing ICC-ES evaluation reports.

ACCEPTANCE CRITERIA FOR MECHANICAL ANCHORS IN CONCRETE ELEMENTS (AC193)

1.0 INTRODUCTION

1.1 Purpose: The purpose of this criteria is to establish requirements for recognition of mechanical anchors in concrete elements in ICC Evaluation Service, Inc. (ICC-ES), evaluation reports under the 2009 *International Building Code*[®], the 2006 *International Building Code*[®] and the 1997 *Uniform Building Code*[™]. Bases of recognition are IBC Section 104.11 and UBC Section 104.2.8.

The reason for development of this criteria is to allow for recognition of the use of mechanical anchors in concrete, since the prescriptive requirements of Chapter 19 of the IBC and Chapter 19 of the UBC need supplemental procedures for establishing the structural capacities of mechanical anchors used to create connections between structural concrete and attachments.

1.2 Scope: This criteria applies to mechanical anchors used to resist loads in cracked and uncracked normal-weight or structural lightweight concrete, including concrete-filled metal deck floor and roof assemblies. The criteria calls for assessment of load capacity, reliability, service conditions, design procedures, and quality control. Special inspection is required during anchor installation, as noted in Section 5.4 of this criteria. Additional statements regarding scope are within Chapters 1 and 3 of ACI 355.2.

1.3 Codes and Referenced Standards: Where standards are referenced in this criteria, these standards shall be applied consistently with the code upon which compliance is based. Standards editions listed in this section apply to all codes. Where standards editions are not listed in this section, Table 1 summarizes the specific date applicable to each code.

1.3.1 2009 *International Building Code*[®] (2009 IBC), International Code Council.

1.3.2 2006 *International Building Code*[®] (2006 IBC), International Code Council.

1.3.3 1997 *Uniform Building Code*[™] (UBC).

1.3.4 ACI 211.1-91 (2002), Standard Practice for Selecting Proportions for Normal, Heavyweight and Mass Concrete, American Concrete Institute.

1.3.5 ACI 211.2-98 (2004), Standard Practice for Selecting Proportions for Structural Lightweight Concrete, American Concrete Institute.

1.3.6 ACI 318 (2005), Building Code Requirements for Structural Concrete, American Concrete Institute.

1.3.7 ANSI B212.15-1994, American National Standard for Cutting Tools—Carbide-Tipped Masonry Drills and Blanks for Carbide-Tipped Masonry Drills, American National Standards Institute.

1.3.8 ACI-355.2, Qualification of Post-Installed Mechanical Anchors in Concrete, American Concrete Institute.

1.3.9 ASTM A 153, Specification for Zinc (Hot-Dip) Coating on Iron and Steel Products, ASTM International.

1.3.10 ASTM A 370, Standard Test Methods and Definitions for Mechanical Testing of Steel Products, ASTM International.

1.3.11 ASTM B 695, Specification for Coatings of Zinc Mechanically Deposited on Iron and Steel, ASTM International.

1.3.12 ASTM C 31, Standard Practice for Making and Curing Concrete Test Specimens in the Field, ASTM International.

1.3.13 ASTM C 33-03, Standard Specification for Concrete Aggregates, ASTM International.

1.3.14 ASTM C 39, Standard Test Method for Compressive Strength of Cylindrical Concrete Specimens, ASTM International.

1.3.15 ASTM C 42, Standard Test Method for Obtaining and Testing Drilled Cores and Sawed Beams of Concrete, ASTM International.

1.3.16 ASTM C 78-00, Standard Test Method for Flexural Strength of Concrete Using Simple Beam with Third-Point Loading, ASTM International.

1.3.17 ASTM C 150, Standard Specification for Portland Cement, ASTM International.

1.3.18 ASTM C 330, Standard Specification for Lightweight Aggregates for Structural Concrete, ASTM International.

1.3.19 ASTM E 4-03, Standard Practices for Force Verification of Testing Machines, ASTM International.

1.3.20 ASTM E 8-04, Standard Test Methods for Tension Testing of Metallic Materials, ASTM International.

1.3.21 ASTM E 119, Standard Test Methods for Fire Tests of Building Construction and Materials, ASTM International.

1.3.22 ASTM E 488-96 (2003), Standard Test Methods for Strength of Anchors in Concrete and Masonry Elements, ASTM International.

1.3.23 ASTM F 1624-06, Standard Test Method for Measurement of Hydrogen Embrittlement Threshold in Steel by the Incremental Step Loading Technique, ASTM International.

1.3.24 ASTM G 5-94 (2004), Standard Reference Test Method for Making Potentiostatic and Potentiodynamic Anodic Polarization Measurements, ASTM International.

1.4 Definitions:

1.4.1 ACI 355.2: The referenced document in Section 1.3.8 with amendments described in Annex 1.

1.4.2 Anchor Test Series: A group of identical anchors tested under identical conditions. Identical conditions are diameter, length, embedment, spacing, edge distance, concrete density/weight, test member thickness, and concrete compressive strength.

1.4.3 Mechanical Anchor: The mechanical anchor includes the displacement-controlled anchor, torque-

ACCEPTANCE CRITERIA FOR MECHANICAL ANCHORS IN CONCRETE ELEMENTS (AC193)

controlled anchor, undercut anchor and screw anchor defined in Section 2.1 of ACI 355.2.

1.4.4 Test Member: The concrete element receiving anchors to be tested.

1.4.5 Other Definitions: Definitions in the IBC, IRC, UBC, ACI 318 Appendix D and ACI 355.2 apply within this criteria.

1.4.6 Test Specimen: The anchor being tested to determine its performance capacities.

2.0 BASIC INFORMATION

2.1 General: The following information shall be submitted:

2.1.1 Product Description: Anchors shall be described as to:

- 2.1.1.1 Generic or trade name.
- 2.1.1.2 Manufacturer's catalog number.
- 2.1.1.3 Nominal thread size.
- 2.1.1.4 Nominal anchor or sleeve diameter.
- 2.1.1.5 Anchor length.
- 2.1.1.6 Permitted manufacturing tolerances.

2.1.1.7 Basic materials, including appropriate physical properties before and after manufacture and protective coatings, shall be described. If the anchor consists of component parts involving different materials, differences shall be noted.

2.1.1.8 Appropriate National Standards for the Materials of the Anchors: Reports of physical properties for materials used in test specimens shall be submitted. The reports shall be generated by a mill or accredited testing laboratory. Where actual material strength exceeds the specified strength, test results shall be adjusted to the specified minimum strength of the anchor material. Where no physical property specification exists, acceptable properties for quality control purposes shall be established by physical property tests.

2.1.2 Installation Instructions: Manufacturer's published instructions for installation, application, and design shall be submitted.

2.1.3 Packaging and Identification: Information on anchor performance and identification shall be determined and reported in accordance with Chapter 6 of ACI 355.2. The methods of packaging anchors shall be described. The manufacturer's name or insignia, and the anchor type and size, shall be marked on the anchor itself or on packaging units. The evaluation report number (ESR-XXXX) and name of the inspection agency shall appear on packaging units.

2.1.4 Field Preparation: Information concerning methods of preparing anchors and concrete for installation shall be described.

2.2 Testing Laboratories: Testing laboratories shall comply with Section 2.0 of the ICC-ES Acceptance Criteria for Test Reports (AC89), and Section 4.2 of the ICC-ES Rules of Procedure for Evaluation Reports. The testing laboratory shall verify that all elements of the test program and analysis were in compliance with this criteria. The

testing laboratory shall conduct or directly verify all procedures. All required testing shall be conducted by an independent accredited testing laboratory in their facility, except that up to 50 percent of the service-condition tests required by ACI 355.2 are permitted to be witnessed by the accredited testing laboratory in the manufacturer's facility, as noted in Annex 1, Section 4.3. Additional testing can be conducted by the manufacturer as noted in Section 4.3 of Annex 1.

2.3 Test Reports: Test reports shall comply with AC85. In addition the test reports shall include information described in Section 13 of ASTM E 488 and Chapter 11 of ACI 355.2, as well as the following:

2.3.1 Mode of failure for each test (e.g., concrete cracking, concrete spalling, anchor pullout, anchor shear, ductile steel failure, etc.).

2.3.2 Photographs of test equipment and typical failures.

2.3.3 Report approval by a registered design professional.

2.3.4 Verification that test specimen sampling complies with Section 2.4.

2.3.5 Manufacturer's published installation instructions.

2.3.6 Strength of Test Specimen Materials: The test report shall note the strength of the test specimen materials. The appropriate specification shall be referenced. When no specification exists, acceptable properties for quality control purposes shall be established by physical tests. A minimum of three anchor element specimens shall be tested to establish steel properties,

2.3.7 Normalization of Concrete and Steel Strengths: Test specimen test capacities shall be normalized, as required, in accordance with Section A1 of ACI 355.2 and the normalized values reported within the test report.

2.4 Product Sampling: Sampling of the mechanical anchors for tests under this criteria shall comply with Sections 3.1, 3.3 and 3.4 of AC85 and Section 4.2 of ACI 355.2.

2.5 Design Loads: The anchor design shall be in accordance with ACI 318 Appendix D. Load combinations specified in Sections D.4.4 and D.4.5 of the ACI 318 Appendix D shall apply in lieu of load combinations in the applicable code. Data obtained from the test reports shall be included in the ICC-ES evaluation report when required or permitted by ACI 318 Appendix D.

2.6 Combined Loads: Loads for anchors subjected to combined tension and shear forces shall be computed in accordance with Section D.7 of ACI 318 Appendix D.

3.0 TEST AND PERFORMANCE REQUIREMENTS

3.1 Durability: When anchors are recognized for exterior exposure or damp environments, evidence of durability shall be submitted. The steel shall be corrosion-resistant, stainless, or zinc-coated steel. The zinc coating shall be either hot-dipped in accordance with ASTM A 153 Class C or D; mechanically deposited in accordance with ASTM B 695 with a Class 65 coating having a minimum thickness of 2.1 mils (0.053 mm); or demonstrated through

ACCEPTANCE CRITERIA FOR MECHANICAL ANCHORS IN CONCRETE ELEMENTS (AC193)

tests to be equivalent to the coatings previously described in this sentence. The corrosion-resistant materials shall be tested as set forth in Annex 1, Section 6.3.5.

3.2 Concrete: The concrete used in the anchor tests of Section 3.3 shall comply with the following:

3.2.1 Concrete mix design shall follow recommendations for proportioning in ACI 211.1 or ACI 211.2 or ACI 318. The concrete shall also comply with Section 5.1 of ACI 355.2. Proportions may be varied to meet local requirements and to achieve desired nominal compressive strength. The reason for any variation shall be described in the test report. No cementitious additives shall be added to the concrete test members.

3.2.2 Portland cement shall comply with ASTM C 150. Additional requirements in Section 5.1.2 of ACI 355.2 apply.

3.2.3 Coarse and fine aggregate in concrete shall comply with ASTM C 33 for normal-weight concrete and ASTM C 330 for structural lightweight concrete. The aggregate description shall include the rock and mineral components, shape, hardness, maximum size, and grading specification. Additional requirements in Section 5.1.1 of ACI 355.2 also apply.

3.2.4 Concrete test cylinders shall be prepared in accordance with ASTM C 31. Cylinders shall be stored and cured in accordance with Section 9.3.1 of ASTM C 31 (field cure). To determine the compressive strength of test members, cylinders shall be tested in accordance with ASTM C 39 and Section 3.2.8 of this criteria.

3.2.5 When no test cylinders are available, or where there is a question as to whether the concrete cylinders represent the concrete compressive strength of the test members, compressive strength shall be determined using drilled cores from test members. Cores shall be obtained, prepared, and tested in accordance with ASTM C 42 and Section 3.2.8 of this criteria.

3.2.6 Test Members:

3.2.6.1 General: Test members shall be prepared in accordance with Section 6.4 of ASTM E 488 and Appendix A3 of ACI 355.2.

3.2.6.2 Concrete-filled Metal Deck: Concrete used as fill on metal deck test specimens shall be prepared in accordance with Annex 1, Section A3.4. Concrete fill on metal decking specimens shall represent the minimum concrete fill thickness, maximum decking depth, minimum flute width and minimum decking thickness for this application. Results for tests conducted in structural lightweight concrete fill shall be permitted to be used for applications in normal-weight concrete fill. Metal decks used in all tests shall be evaluated by material property tests to determine the tensile strength, yield strength, and elongation in accordance with the appropriate standard for the metal grade. In addition, the base-metal thickness shall be determined, exclusive of coatings. Test results shall be based on the evaluation of three specimens in each thickness. Where measured properties vary from specified values, the influence of the variations on anchor tests shall be considered in the analysis.

3.2.7 Reinforcement may only be used to stabilize test members during transportation or as required in

Sections A3.1.2 and A3.2 of ACI 355.2. Reinforcing elements in concrete test members shall be outside the potential failure region of each test specimen or anchor group. The test laboratory shall verify the location of the reinforcing.

3.2.8 Compressive Strength Determination:

3.2.8.1 Concrete compressive strengths at time of anchor tests shall comply with the ranges specified in Section 5.1.3 of ACI 355.2.

3.2.8.2 Test members shall be cured a minimum of 21 days prior to the beginning of anchor tests in accordance with Section A3.3 of ACI 355.2.

Exception: For tests to determine performance in high-early-strength or uncured concrete, a lesser curing period may be used.

3.2.8.3 Where high-early-strength cement is used, curing shall be for a minimum of seven days, with a two-day allowable minus tolerance. Two cylinders shall be tested in accordance with ASTM C 39 to determine compressive strength. The average compressive strength shall be determined within 12-hour period immediately preceding or following any test series.

3.2.8.4 For concrete less than 90 days old, two tests of two cylinders, or cores, each prepared according to Section 3.2.4 of 3.2.5, shall be performed at the beginning and ending of anchor testing in accordance with Table 1. The beginning of the anchor test shall be concurrent with the initiation of anchor testing. The beginning and ending strength results shall be averaged (four cylinders or cores, total) to establish the strength of the test members during the test period.

3.2.8.5 For concrete aged 90 days or more, the compressive strength test shall be a single test of three cylinders or cores, performed within 30 days of any anchor testing.

3.2.8.6 Reported concrete compressive strength for any anchor test series shall be determined from tests in this section, within the time limitations shown in Table 2 of this criteria.

3.3 Anchor Load Test Program:

3.4 Anchor tests shall be performed in accordance with Section 4.1 of this criteria.

3.5 Test Specimen Behavior: Test specimen behavior shall be evaluated and reported in accordance with Section 5.5 of ACI 355.2. The report shall be sealed by a registered design professional.

3.6 Test Specimen Categories: Test specimen categories shall be determined and reported based on the characteristic capacities in accordance with Chapter 10 and Appendix A2 of ACI 355.2. The report shall be sealed by a registered design professional.

3.7 Fire Resistance (Optional): Test specimens intended for fire-resistive construction shall be evaluated for load resistance during fire exposure. General guidelines for fire exposure are in ASTM E 119.

3.8 Changes to Product: Changes to product shall be qualified in accordance with Section 4.4 of ACI 355.2. ICC-ES shall approve the test program before tests are conducted.

ACCEPTANCE CRITERIA FOR MECHANICAL ANCHORS IN CONCRETE ELEMENTS (AC193)

4.0 TEST METHODS

4.1 Load Test Requirements:

4.1.1 Test requirements are summarized in Section 4.1 and Tables 4.1 and 4.2 of ACI 355.2.

4.1.2 Reference tests shall be conducted in accordance with Section 7.0 of ACI 355.2, based on the schedules in Section Tables 4.1 and 4.2 of ACI 355.2.

4.1.3 Reliability tests shall be conducted in accordance with Section 8.0 of ACI 355.2 based on the schedules in Section Tables 4.1 and 4.2 of ACI 355.2.

4.1.4 Service-condition tests shall be conducted in accordance with Section 9.0 of ACI 355.2 based on the schedules in Section Tables 4.1 and 4.2 of ACI 355.2.

4.1.5 Tests in cracked concrete shall conform to Section 5.4 of ACI 355.2

4.1.6 Holes for test specimens shall be drilled and cleaned in accordance with manufacturer's published recommendations, including recommendations on hole diameter and depth. All procedures shall be conducted or directly verified by an accredited testing laboratory acceptable to ICC-ES.

4.1.7 Concrete used in the anchor load tests shall comply with Section 3.2 of this criteria.

4.1.8 Only tools typically used in field installations are permitted. Brand, model number, and size of power tool and drill bit shall be reported. Drill bit requirements shall comply with Section 5.2.2 of ACI 355.2. Compliance with applicable standards, such as ANSI B212.15, shall be reported when appropriate. Diameters and lengths of drill bits used in tests shall be measured and reported by the testing laboratory.

4.1.9 All test specimens shall be installed perpendicular to the surface of the test member within a 6-degree tolerance, in a manner representative of actual field installations.

4.1.10 Installation and setting of test specimens shall comply with Section 5.2 of ACI 355.2. Pertinent data such as anchor embedment, displacement, depth, nominal torque, etc., shall be observed and noted by the test laboratory.

4.1.11 Test equipment for pullout and shear loading shall be adequate to impose anticipated ultimate loads and shall comply with the requirements of ASTM E 488. If loading is not carried to failure, the highest value achieved will be considered the ultimate load.

4.1.12 Direction of loading for all tensile testing shall be coaxial with the embedded test specimen.

4.1.13 The test equipment shall not impose pullout or shear reaction loading on the surface or edge of the concrete test member within a distance given in Table 2 of ASTM E 488. Equipment used to apply a shear load shall be designed to minimize frictional resistance, using a concrete surface finish specified in ASTM E 488 and Section 5.2.1.2 of ACI 355.2.

4.1.14 Displacements under tension and shear loading shall be recorded in a continuous manner for each test specimen tested. The displacement shall be measured as a function of the direction of load application. ASTM E 488, Section 5.5, "Anchor Displacement

Measurement," and Section 8.6.1, "Continuous Load Application," shall apply.

4.1.15 Embedment: Test specimens shall be tested at the minimum embedment, h_{ef} , for which recognition is desired. For recognition of variable embedment depths, test specimens shall be tested in accordance with Section 5.5.3.2 of ACI 355.2. Values for untested intermediate depths may be interpolated from test results.

4.1.16 Slab Thickness: The minimum allowable slab thickness shall be 2 times h_{ef} , unless other thicknesses are substantiated with acceptable test data. See Annex 1, Sections 9.1.1 to 9.1.3.

5.0 QUALITY CONTROL

5.1 The products shall be manufactured under an approved quality control program with inspections by an inspection agency accredited by the International Accreditation Service (IAS) or as otherwise acceptable to ICC-ES. The program shall address requirements in Section 6.3.3 of ACI 355.2, except that inspection agency inspections shall be done at least four times per year.

5.2 Quality documentation complying with the ICC-ES Acceptance Criteria for Quality Documentation (AC10) shall be submitted.

5.3 Where anchors are used for seismic or wind load resistance, **special inspection requirements** shall conform to Sections 1705, 1706 and 1707 of the IBC.

5.4 Special inspection is required in accordance with Section 1704.13 of the IBC and Section 1701.5.2 of the UBC. For each type of anchoring system, the manufacturer shall submit inspection procedures to verify proper usage.

6.0 EVALUATION REPORT RECOGNITION

6.1 The evaluation report shall state that structural design of anchors shall be done in accordance with ACI 318, Appendix D.

6.2 The evaluation report shall include a description of the anchors, design loads, stiffnesses or other load deflection information, installation requirements, special inspection requirements, product identification. The report shall also include the following findings:

6.2.1 Fatigue and Shock Loading: Since an ICC-ES acceptance criteria for evaluating data to determine the performance of anchors subjected to fatigue or shock loading is unavailable at this time, the use of these anchors under these conditions is beyond the scope of this report.

6.2.2 Fire-resistive Construction: (*This version applies to torque-controlled expansion anchors and undercut anchors.*) Where not otherwise prohibited in the code, anchors are permitted for use with fire-resistance-rated construction provided that at least one of the following conditions is fulfilled:

- Anchors are used to resist wind or seismic forces only.
- Anchors that support a fire-resistance-rated envelope or a fire-resistance-rated membrane, are protected by approved fire-resistance-rated materials, or have been evaluated for resistance to fire exposure in accordance with recognized standards.

ACCEPTANCE CRITERIA FOR MECHANICAL ANCHORS IN CONCRETE ELEMENTS (AC193)

- Anchors are used to support nonstructural elements.
- (This version applies to displacement-controlled anchors and screw anchors.) Anchors are not permitted to support fire-resistance-rated construction. Where not otherwise prohibited by the code, anchors are permitted for installation in fire-resistance-rated construction provided that at least one of the following conditions is fulfilled.
- Anchors are used to resist wind or seismic forces only.
- Anchors that support gravity load-bearing structural elements are within a fire-resistance-rated envelope or a fire-resistance-rated membrane, are protected by approved fire-resistance-rated materials, or have been evaluated for resistance to fire exposure in accordance with recognized standards.
- Anchors are used to support nonstructural elements.

6.3 Mandatory Information: The evaluation report shall include the information summarized in Tables 11.1 and 11.2 of ACI 355.2 and the following:

6.4 Optional Information: The evaluation report may include the following information, based on the evaluation under ACI 355.2 and this criteria:

6.4.1 Information on seismic use in structures assigned to Seismic Design Category C, D, E, or F (IBC) or Seismic Zone 2, 3, or 4 (UBC).

6.4.2 Information on use in structural lightweight concrete.

6.4.3 Strength design values determined in accordance with ACI 318 Appendix D may be converted to values suitable for use with allowable stress design load combinations. Conversions shall be in accordance with the following:

6.4.3.1 General: For anchors designed using load combinations in accordance with IBC Section 1605.3 (Allowable Stress Design), allowable loads shall be established using the equations below:

$$T_{allowable, ASD} = \frac{\phi N_n}{\alpha}$$

and

$$V_{allowable, ASD} = \frac{\phi V_n}{\alpha}$$

where:

- $T_{allowable, ASD}$ = Allowable tension load (lbf or kN)
- $V_{allowable, ASD}$ = Allowable shear load (lbf or kN)
- N_n = Lowest design strength of an anchor or anchor group in tension as determined in accordance with ACI 318 Appendix D and 2009 IBC Section 1908.1.9 or 2006 IBC Section 1908.1.16.
- V_n = Lowest design strength of an anchor or anchor group in shear as determined in accordance with ACI

318 Appendix D and 2009 IBC Section 1908.1.9 or 2006 IBC Section 1908.1.16.

α = Conversion factor calculated as a weighted average of the load factors for the controlling load combination. In addition, α shall include all applicable factors to account for non-ductile failure modes and required over-strength.

The interaction shall be calculated in compliance with ACI 318 Appendix D Section D.7 as follows:

For shear loads $V \leq 0.2V_{allowable, ASD}$, the full allowable load in tension shall be permitted.

For tension loads $T \leq 0.2T_{allowable, ASD}$, the full allowable load in shear shall be permitted.

$$\text{For all other cases: } \frac{T}{T_{allowable}} + \frac{V}{V_{allowable}} \leq 1.2$$

6.4.4 A single table for illustration of calculated Allowable Stress Design (ASD) values for each anchor diameter and embedment with the following design assumptions (listed as footnotes to the table) shall be included in the evaluation report:

1. Single anchor with static tension load only
2. Concrete determined to remain uncracked for the life of the anchorage
3. Load combination 9-2 from ACI 318 Section 9.2 (no seismic loading)
4. 30% dead load and 70% live load, controlling load combination 1.2D + 1.6L
5. Calculation of weighted average for $\alpha = 0.3*1.2 + 0.7*1.6=1.48$
6. $f'_c = 2,500$ psi (normal weight concrete)
7. $C_{a1} = C_{a2} \geq C_{ac}$
8. $h \geq h_{min}$

Table title: "Example Allowable Stress Design Values for Illustrative Purposes"

6.4.5 Relevant dimensional information for the use of anchors in concrete-filled metal deck floor and roof assemblies, as well as the supplemental conditions for design contained in Annex 1, Sections 10.3, 10.4, 10.5 and 10.6. Such information shall reflect the specimens used for testing.

6.5 Limitations:

6.5.1 Evaluation reports shall note that use of anchors in structures assigned to Seismic Design Categories C, D, E or F (IBC); or Seismic Zones 2, 3, or 4 (UBC), is beyond the scope of the report.

Exception: Anchors qualified in accordance with test numbers 18 and 19, Annex 1, Table 4.2.

6.5.2 The evaluation report shall note that the design of screw anchors in accordance with ACI 318 Appendix D is valid for screw anchors with a thread length of at least 80 percent of the nominal embedment depth. Anchors with a thread length less than 80 percent of the

ACCEPTANCE CRITERIA FOR MECHANICAL ANCHORS IN CONCRETE ELEMENTS (AC193)

nominal embedment depth shall be designed as single anchors.

6.5.3 The evaluation report shall note that use of anchors in lightweight concrete is beyond the scope of the report.

Exceptions:

1. The use of anchors in structural sand-lightweight concrete shall be recognized provided that, in lieu of ACI 318 D.3.4, N_b , N_{pn} , V_b and V_{cp} shall be multiplied by 0.60.

2. The use of anchors in structural lightweight concrete-filled metal deck assemblies shall be recognized provided the anchors are qualified with structural lightweight concrete in accordance with test numbers 21 and 22, Annex 1, Table 4.2.

3. The use of anchors for redundant applications in structural sand-lightweight concrete shall be recognized provided that, F_{ra} shall be multiplied by 0.60

6.6 Special Inspection: Special inspection details based on information described in Section 5.4 shall be included in the evaluation report. The special inspector shall make periodic inspections during anchor installation to verify anchor type, anchor dimensions, concrete type, concrete compressive strength, hole dimensions, anchor spacing, edge distances, concrete thickness, anchor embedment, and adherence to the manufacturer's published installation instructions. The special inspector shall be present as often as required in accordance with the "statement of special inspection."

6.7 Redundant Applications: For anchors qualified exclusively for use in redundant applications as defined in Section 2.1.18 of Annex 1, the evaluation report shall include the information summarized in Table 11.3 in Annex 1 of this criteria. Anchor design shall be in accordance with Appendix A4 of Annex 1. ■

TABLE 1—APPLICABLE EDITIONS OF REFERENCED STANDARDS

REFERENCED STANDARD	STANDARD EDITION	
	2009 IBC	2006 IBC
ACI 318	2008	2005
ACI 355	2007	2004
ASTM A 153	2005	2003
ASTM B 695	2004	2000
ASTM C 31	2006	1998
ASTM C 39	2005	2003
ASTM C 42	2004	2003
ASTM C 150	2007	2004
ASTM C 330	2005	2004
ASTM E 119	2007	2000

TABLE 2—STRENGTH TEST TIME LIMITATIONS

AGE OF CONCRETE AT BEGINNING OF ANCHOR TEST	MAXIMUM TIME BETWEEN STRENGTH TESTS (Test Period)	COMMENTS
Less than 21 days	3 days	See Sections 3.2.8.2 and 3.2.8.3, for special tests only
21–35 days	7 days	None
36–56 days	14 days	None
57–90 days	30 days	None
More than 90 days	60 days	See Section 3.2.8.5

ANNEX 1

Annex 1 summarizes amendments to ACI 355.2. These amendments supersede applicable portions in ACI 355.2. For the purpose of satisfying this acceptance criteria, Annex 1 shall be used with ACI 355.2. The revisions herein reflect the difference in content from ACI 355.2. Tables of ACI 355.2 that are modified by this Annex are presented in their modified form in Annex 1. The numbering system within Annex 1 of AC193 uses the number that corresponds to the location in ACI 355.2 where that change would be located. The revisions herein reflect the difference in content from ACI 355.2.

Keywords: anchors; cracked concrete; expansion anchors; fasteners; mechanical anchors; post-installed anchors; screw anchors; undercut anchors, redundant applications.

1.3 ACI 355.2 applies only to post-installed mechanical anchors (torque-controlled expansion anchors, displacement controlled expansion anchors, undercut anchors and screw anchors), placed into predrilled holes and anchored within the concrete by mechanical means.

1.4 ACI 355.2 applies to post-installed expansion and undercut anchors with an effective embedment depth h_{ef} , greater than or equal to $1\frac{1}{2}$ inches (40 mm) and post-installed screw anchors with $(h_{nom} - h_s)$ greater than or equal to $1\frac{1}{2}$ inches (40 mm).

Exception: Where qualified exclusively for use in redundant applications as defined in Section 2.1.18, ACI 355.2 applies to post-installed expansion and undercut anchors and having an effective embedment depth greater than or equal to 1 inch (25 mm) and post-installed screw anchors with $(h_{nom} - h_s)$ greater than or equal to 1 inch (25 mm).

2.1.10 *Screw anchor* – A post-installed anchor that is a threaded mechanical fastener placed in a predrilled hole. The anchor derives its tensile holding strength from the mechanical interlock of the fastener threads with the grooves cut into the concrete during the anchor installation.

2.1.11 through 2.1.17 – Re-number all referenced sections accordingly. Current 2.1.10 becomes 2.1.11, etc.

2.1.19 Redundant applications – Applications in which multiple anchors support linear elements that are capable, in the event that one anchor fails or exhibits excessive deflection, of redistributing the load to neighboring anchors. Anchors qualified exclusively for use in redundant applications shall not be used in single anchor applications or in group anchorages. Anchors shall be limited to interior applications. Where durability is established in accordance with Section 3.1 of AC 193, the exception to Section 1.4 does not apply.

2.2—Notation

c_{cr} = edge distance necessary to develop the full concrete breakout strength of a single anchor without spacing and edge effects, in. (mm)

h_{ef} = effective embedment depth, in. (mm) for expansion and undercut anchors measured from the concrete surface to the deepest point at which the anchor tension load is transferred to the concrete; see Fig. 2.4;
for screw anchors = $0.85(h_{nom} - 0.5h_t - h_s)$; see Fig. 2.6

Insert the following notation:

F_{ar} = characteristic resistance of an anchor in cracked concrete for anchors qualified exclusively for redundant applications, lb. (N).

$F_{ra,deck}$ = characteristic resistance of an anchor installed through the soffit of concrete-filled metal deck floor and roof assemblies for anchors qualified exclusively for redundant applications, lb. (N).

h_{nom} = distance between embedded end of concrete screw and concrete surface, in. (mm)

h_s = length of the embedded end of the screw anchor without full height of thread (= thread runout + length without thread), in. (mm)

h_t = thread pitch, in. (mm)

h_{hole} = overall depth of the drilled hole, in. (mm)

N_{eq} = the maximum tension load to be applied in the simulated seismic tension test in accordance with Table 9.1, Fig. 9.1 and Eq. (9-1), lb (N)

N_i = the intermediate tension load to be applied in the simulated seismic tension test in accordance with Table 9.1 and Fig. 9.1, equal to $0.75N_{eq}$, lb (N)

N_m = the minimum tension load to be applied in the simulated seismic tension test in accordance with Table 9.1 and Fig. 9.1, equal to $0.50N_{eq}$, lb (N)

ACCEPTANCE CRITERIA FOR MECHANICAL ANCHORS IN CONCRETE ELEMENTS (AC193)

$N_{eq, reduced}$	=	a reduced maximum tension load at which the anchor successfully completes the simulated seismic tension test, lb (N)
$N_{i, reduced}$	=	a reduced intermediate tension load at which the anchor successfully completes the simulated seismic tension test, equal to $0.75N_{eq, reduced}$, lb (N)
$N_{m, reduced}$	=	a reduced minimum tension load at which the anchor successfully completes the simulated seismic tension test, equal to $0.50N_{eq, reduced}$, lb (N)
N_{ra}	=	characteristic tensile capacity of an anchor in cracked concrete for anchors qualified exclusively for redundant applications. (5% fractile of test results.), lb. (N).
$N_{st, mean}$	=	average ultimate steel capacity determined from tensile tests on full-sized anchor specimens, lb (N)
$N_{u, con, mean}$	=	average ultimate load determined from confined reference tests, lb (N).
$N_{sust, con}$	=	sustained load used for confined reference tests, lb (N).
T_{screw}	=	specified maximum setting torque to prevent anchor failure during installation, ft-lb. (N-m)
T_u	=	mean ultimate torque moment, as measured in setting method tests, ft-lb (N-m)
$T_{5\%}$	=	5% fractile of the ultimate torque moments, T_u , calculated in accordance with ACI 355.2, Section A2, ft-lb (N-m)
V_{eq}	=	the maximum shear load to be applied in the simulated seismic shear test in accordance with Table 9.2, Fig. 9.2 and either Eq. (9-3) or Eq. (9-4), lb (N)
V_i	=	the intermediate shear load to be applied in the simulated seismic shear test in accordance with Table 9.2 and Fig. 9.2, equal to $0.75V_{eq}$, lb (N)
V_m	=	the minimum shear load to be applied in the simulated seismic shear test in accordance with Table 9.2 and Fig. 9.2, equal to $0.50V_{eq}$, lb (N)
$V_{eq, reduced}$	=	a reduced maximum shear load at which the anchor successfully completes the simulated seismic shear test, lb (N)
$V_{i, reduced}$	=	a reduced intermediate shear load at which the anchor successfully completes the simulated seismic shear test, equal to $0.75V_{eq, reduced}$, lb (N)
$V_{m, reduced}$	=	a reduced minimum shear load at which the anchor successfully completes the simulated seismic shear test, equal to $0.50V_{eq, reduced}$, lb (N)
V_{ra}	=	characteristic shear capacity of an anchor in cracked concrete for anchors qualified exclusively for redundant applications. (5% fractile of test results.), lb. (N).
V_s	=	nominal shear strength in shear of a single anchor as governed by the steel strength in accordance with ACI 318, lb (N)

Fig 2.4 – Insert new Fig. 2.4. Renumber figure 2.4 to become Figure 2.5.

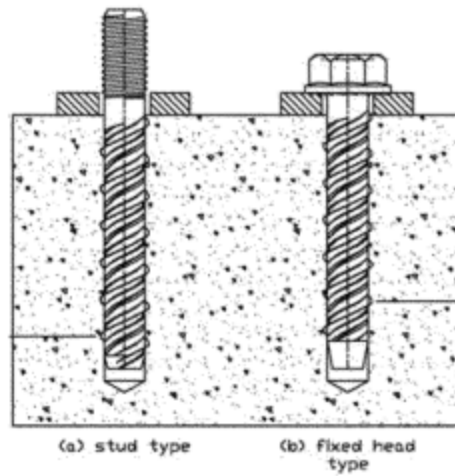

Revise caption of Fig. 2.5 (old Fig 2.4)

Fig. 2.5 – Effective embedment depth of expansion and undercut anchors

Fig. 2.6 - Insert new Fig. 2.6

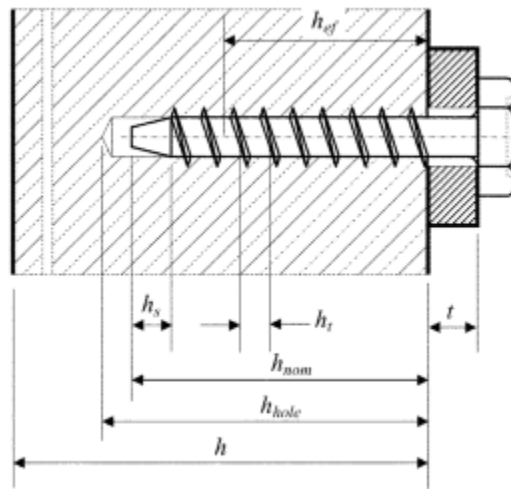

Fig. 2.6 – Effective embedment depth of screw anchors.

3.1 ACI 355.2 applies to post-installed mechanical anchors intended for use in structural applications addressed by ACI 318 and subjected to static or seismic loads in tension, shear, or combined tension and shear. Applicable anchors are shown in Fig. 2.1, 2.2, 2.3 and 2.4 (balance of section unchanged).

Exceptions: Where qualified exclusively for use in redundant applications as defined in Section 2.1.18, ACI 355.2 applies to post-installed mechanical anchors subjected to static or wind loads in tension, shear, or combined tension and shear. Applicable anchors are shown in Fig. 2.1, 2.2, 2.3 and 2.4.

ACCEPTANCE CRITERIA FOR MECHANICAL ANCHORS IN CONCRETE ELEMENTS (AC193)

Replace Table 4.1 with the following:

TABLE 4.1—TEST PROGRAM FOR EVALUATING ANCHOR SYSTEMS FOR USE IN UNCRACKED CONCRETE

Test Number	Reference	Purpose	Description	Concrete Strength	Member Thickness	Drill Bit Diameter	Minimum Sample Size*
<i>Reference tests</i>							
1	7.2.1	Reference test in uncracked low-strength concrete	Tension-single anchor with no edge influence	Low	$\geq h_{min}$	d_m	5
2	7.2.1	Reference test in uncracked high-strength concrete	Tension-single anchor with no edge influence	High	$\geq h_{min}$	d_m	5
3	7.2.2	Reference test for screw anchors- Confined test in uncracked high-strength concrete	Confined tension - single anchor away from edges	High	$\geq h_{min}$	d_m	5 ^{a,b}
<i>Reliability tests</i>							
4	8.2	Sensitivity to reduced installation effort	Tension-single anchor with no edge influence	Varies with anchor	$\geq h_{min}$	d_m^\dagger	5
5	8.3	Sensitivity to large hole diameter	Tension-single anchor with no edge influence	Low	$\geq h_{min}$	d_{max}	5
6	8.4	Sensitivity to small hole diameter	Tension-single anchor with no edge influence	High	$\geq h_{min}$	d_{min}	5
7	8.5	Reliability under repeated load	Repeated tension-single anchor with no edge influence, residual capacity	Low	$\geq h_{min}$	d_m	5 [‡]
8	8.7	Reliability of screw anchors against brittle failure	Method A Embrittlement test - single anchor away from edges	High	$\geq h_{min}$	d_m	5 ^{a,b}
			Method B Embrittlement test	-	-	-	c
9	8.8.2	Reliability of screw anchors when set with impact screw driver	Setting test – single anchor away from edges	Low	$\geq h_{min}$	d_{max}	15
10	8.8.3	Reliability of screw anchors when set with a torque wrench in low-strength concrete	Setting test – single anchor away from edges	Low	$\geq h_{min}$	d_{max}	10
11	8.8.4	Reliability of screw anchors when set with a torque wrench in high-strength concrete	Setting test – single anchor away from edges	High	$\geq h_{min}$	d_{min}	10
<i>Service-condition tests</i>							
12	9.2	Verification of full concrete capacity in corner with two edges located at $1.5h_{ef}$	Tension-single anchor with two edges located at $1.5h_{ef}$	Low	h_{min}	d_m	4
13	9.3	Minimum spacing and edge distance to preclude splitting on installation	High installation tension (torque or direct)-two anchors near edge	Low	h_{min}	d_m	5
14	9.4	Shear capacity of anchor steel [§]	Shear-single anchor with no edge influence	Low	$\geq h_{min}$	d_m	5
15	9.7	Torque Test (Optional)	Effect of torque on anchor tension force	High	$\geq h_{min}$	d_m	5

*Minimum sample size for each anchor diameter, unless otherwise noted.

†Drilling diameters for undercuts are specified in Table 5.6.

‡Tests are not required for each anchor diameter. Test smallest, middle, and largest anchor diameter. For screw anchors, test all diameters.

§Test all diameters at minimum embedment, h_{ef} .

^aTests are not required if the conditions in Section 8.7.1.1 are fulfilled.

^bPerform tests to match those required in Sections 8.7.2.1 or 8.7.2.2.

^cThe number of test specimens is described in Section 8.7.2.2.3.5.1.

ACCEPTANCE CRITERIA FOR MECHANICAL ANCHORS IN CONCRETE ELEMENTS (AC193)

Replace Table 4.2 with the following:

TABLE 4.2—TEST PROGRAM FOR EVALUATING ANCHOR SYSTEMS FOR USE IN CRACKED AND UNCRACKED CONCRETE

Test Number	Reference	Purpose	Description	Crack Opening Width, in (mm)	Concrete Strength	Member Thickness	Drill Bit Diameter	Minimum Sample Size, n
<i>Reference tests</i>								
1	7.2.1	Reference test in uncracked low-strength concrete	Tension-single anchor with no edge influence	—	Low	$\geq h_{min}$	d_m	5
2	7.2.1	Reference test in uncracked high-strength concrete	Tension-single anchor with no edge influence	—	High	$\geq h_{min}$	d_m	5
3	7.2.1	Reference test in cracked low-strength concrete	Tension-single anchor with no edge influence	0.012 (0.3)	Low	$\geq h_{min}$	d_m	5
4	7.2.1	Reference test in cracked high-strength concrete	Tension-single anchor with no edge influence	0.012 (0.3)	High	$\geq h_{min}$	d_m	5
5	7.2.2	Reference test for screw anchors - Confined test in uncracked high-strength concrete	Confined tension - single anchor away from edges	—	High	$\geq h_{min}$	d_m	5 ^{a,b}
<i>Reliability tests</i>								
6	8.2	Sensitivity to reduced installation effort	Tension-single anchor with no edge influence	0.012 (0.3)	Varies with anchor type	$\geq h_{min}$	d_m^\dagger	5
7	8.3	Sensitivity to crack width and large hole diameter	Tension-single anchor with no edge influence	0.020 (0.5)	Low	$\geq h_{min}$	d_{max}	5
8	8.4	Sensitivity to crack width and small hole diameter	Tension-single anchor with no edge influence	0.020 (0.5)	High	$\geq h_{min}$	d_{min}	5
9	8.6	Tests in cracks whose opening width is cycled	Sustained tension-single anchor with no edge influence, residual capacity	0.004 to 0.012 (0.1 to 0.3)	Low	$\geq h_{min}$	d_{max}^\S	5
10	8.5	Reliability of screw anchors under repeated load	Repeated tension – single anchor away from edges, residual capacity	—	Low	$\geq h_{min}$	d_m	5
11	8.7	Reliability of screw anchors against brittle failure	Method A Embrittlement test - single anchor away from edges	—	High	$\geq h_{min}$	d_m	5 ^{a,b}
			Method B Embrittlement Test	-	-	-	-	c
12	8.8.2	Reliability of screw anchors when set with impact screw driver	Setting test – single anchor away from edges	—	Low	$\geq h_{min}$	d_{max}	15
13	8.8.3	Reliability of screw anchors when set with a torque wrench in low-strength concrete	Setting test – single anchor away from edges	—	Low	$\geq h_{min}$	d_{max}	10
14	8.8.4	Reliability of screw anchors when set with a torque wrench in high-strength concrete	Setting test – single anchor away from edges	—	High	$\geq h_{min}$	d_{min}	10
<i>Service-condition tests</i>								
15	9.2	Verification of full concrete capacity in corner with two edges located at $1.5h_{ef}$	Tension-single anchor with two edges located at $1.5h_{ef}$	—	Low	h_{min}	d_m	4
16	9.3	Minimum spacing and edge distance to preclude splitting on installation	High installation tension (torque or direct)-two anchors near edge	—	Low	h_{min}	d_m	5
17	9.4	Shear capacity of anchor steel [‡]	Shear-single anchor with no edge influence	—	Low	$\geq h_{min}$	d_m	5
18	9.5	Seismic tension	Pulsating tension, single anchor, with no edge influence	0.020 (0.5)	Low	$\geq h_{min}$	d_m	5
19	9.6	Seismic shear	Alternating shear, single anchor, with no edge influence	0.020 (0.5)	Low	$\geq h_{min}$	d_m	5
20	9.7	Torque Test (Optional)	Effect of torque on anchor tension force	—	High	$\geq h_{min}$	d_m	5
21	9.8	Tension capacity in concrete fill on deck-soffit installation	Tension–single anchor away from edges	—	Low or high	h_{min}	d_m	5
22	9.9	Shear capacity in concrete fill on deck soffit installation	Shear toward nearest edge of flute–single anchor in lower flute	—	Low or high	h_{min}	d_m	5

*Minimum sample size for each anchor diameter, unless otherwise noted.

†Drilling diameters for undercuts are specified in Table 5.6.

‡Test all diameters at minimum embedment, h_{ef} .

§Test of undercut anchors use d_m .

||These tests are optional.

ACCEPTANCE CRITERIA FOR MECHANICAL ANCHORS IN CONCRETE ELEMENTS (AC193)

¹If the critical edge distance is $c_{cr} \geq 1.5 h_{ef}$ then for applications with $c < c_{cr}$ in at least one direction, the concrete breakout strength of anchors in tension calculated according to ACI 318 D5.2, shall be multiplied by a factor ψ_{edge} given by Eq. (9-1).

^aTests are not required if the conditions in 8.7.1.1 are fulfilled.

^bPerform tests to match those required in Sections 8.7.2.1 or 8.7.2.2.

^cThe number of test specimens is described in Section 8.7.2.2.3.5.1.

New Table 4.3:

TABLE 4.3 — TEST PROGRAM FOR EVALUATING ANCHORS QUALIFIED EXCLUSIVELY FOR REDUNDANT APPLICATIONS IN CRACKED AND UNCRACKED CONCRETE

Test Number	Reference	Purpose	Description	Crack width in. (mm)	Concrete Strength	Member Thickness	Drill Diameter	Minimum Sample Size ^a , n
<i>Reference tests</i>								
1	7.2.1	Reference test in uncracked low-strength concrete	Tension-single anchor with no edge influence	-	low	$\geq h_{min}$	d_m	5
2	7.2.1	Reference test in cracked low-strength concrete	Tension-single anchor with no edge influence	0.008 (0.2)	low	$\geq h_{min}$	d_m	5
3	7.2.2	Reference test for screw anchors in uncracked low-strength concrete b	Confined tension - single anchor away from edges	-	low	$\geq h_{min}$	d_m	5
<i>Reliability tests</i>								
4	8.2	Sensitivity to reduced installation effort	Tension-single anchor with no edge influence	0.008 (0.2)	Varies with anchor type	$\geq h_{min}$	d_{max}	5
5	8.3	Sensitivity to crack width and large hole diameter	Tension-single anchor with no edge influence	0.014 (0.35)	low	$\geq h_{min}$	d_{max}	5
6	8.4	Sensitivity to crack width and small hole diameter	Tension-single anchor with no edge influence	0.014 (0.35)	high	$\geq h_{min}$	d_{min}	5
7	8.5	Reliability under repeated load	Repeated tension - single anchor with no edge influence, residual tension	-	low	$\geq h_{min}$	d_m	3
8	8.7	Reliability of screw anchors against brittle failure b	Method A - Embrittlement Test	-	low	$\geq h_{min}$	d_m	5
			Method B - Embrittlement Test	-	-	$\geq h_{min}$	-	c
9	8.8.2	Reliability of screw anchors when set with a impact screw driver	Setting test-single anchor with no edge influence	-	low	-	d_{max}	15
10	8.8.3	Reliability of screw anchors when set with a torque wrench in low strength concrete	Setting test-single anchor with no edge influence	-	low	$\geq h_{min}$	d_{max}	10
11	8.8.4	Reliability of screw anchors when set with a torque wrench in high strength concrete	Setting test-single anchor with no edge influence	-	high	$\geq h_{min}$	d_{min}	10
<i>Service-condition tests</i>								
12	9.4	Shear capacity of anchor	Shear-single anchor with no edge influence	0.008 (0.2)	low	$\geq h_{min}$	d_m	5d
13	9.8	Tension capacity in concrete fill on deck-soffit installation	Tension-single anchor away from edges	-	low	h_{min}	d_m	5
14	9.9	Shear capacity in concrete fill on deck-soffit installation	Shear toward nearest edge of flute - single anchor, lower flute	-	low	h_{min}	d_m	5

a. Drilling diameters for undercut anchors are specified in Table 5.6

b. Tests are not required if the conditions in Section 8.7.1.1 are fulfilled

c. The number of test specimens is described in Section 8.7.2.2.3.5.1

d. Tests are required at minimum embedment. Additional tests may be performed at deeper embedments.

4.1 Test Sequence

Perform four types of tests in the following sequence:

1. Identification tests to evaluate the anchor’s compliance with the critical characteristics (Chapter 6);
2. Reference tests to establish baseline performance against which subsequent tests are to be compared (Chapter 7);
3. Reliability tests to confirm the reliability of the anchor under adverse installation procedures and long-term use (Chapter 8); and
4. Service-condition tests to evaluate the performance of the anchor under expected service conditions (Chapter 9).

Test requirements are summarized in Tables 4.1 and 4.2. Determine the acceptability of the anchor using the criteria prescribed in Chapter 6 through 9. Determine the anchor category (an index of the anchor’s sensitivity to conditions of installation and use) using the criteria prescribed in Chapter 10. Report the lowest anchor category by diameter as prescribed in Chapter 11. For anchors with multiple embedment depths, refer to Table 5.7.

ACCEPTANCE CRITERIA FOR MECHANICAL ANCHORS IN CONCRETE ELEMENTS (AC193)

Exception: For anchors qualified exclusively for redundant applications, test requirements are summarized in Table 4.3. Determine the acceptability of the anchor using the criteria prescribed in Chapters 6 through 9. Determine the anchor category (an index of the anchor's sensitivity to conditions of installation and use) using the criteria prescribed in Chapter 10. For anchors with multiple embedment depths, refer to Table 5.7.

4.2.2 For anchor systems supplied with different materials, pretensioning application mechanisms, or coatings, or that are manufactured with different production methods, perform the torque tests in accordance with Section 9.7.4. If the results do not meet the requirements of Section 9.7.4.2, perform the complete test program for each anchor material, coating, production method, or pretensioning application mechanism.

4.2.3 The sample size given in Tables 4.1, 4.2 and 4.3 are the minimum required to satisfy the requirements of the standard. At the discretion of the independent testing and evaluation agency or manufacturer, the sample size shall be permitted to be increased.

4.3—Testing by Manufacturer

The required minimum number of reference and reliability and at least 50% of the service-condition test series given in Table 4.1, 4.2 and 4.3 of AC193 shall be performed by the independent testing and evaluation agency (Section 12.0) in their facility. Not more than 50% of the sample tested for each service-condition test series required by ACI 355.2 shall be permitted to be performed by the manufacturer. All such tests shall be witnessed by an independent accredited testing laboratory.

Additional results of tests performed by the manufacturer shall be permitted to be considered in the evaluation. All tests performed by the manufacturer shall be permitted to be considered only if the results are statistically equivalent to those of the independent testing and evaluation agency (Section 2.1.12). The number of tests conducted by the manufacturer shall not exceed the number of tests by the independent accredited testing laboratory.

4.4—Changes to Product

Before an anchor is changed, the manufacturer shall report the nature and significance of the change to the independent test and evaluation agency (Chapter 12.0), who shall determine which tests (if any) shall be performed.

4.4.1 Tests for determining equivalence of expansion and undercut anchors of different production methods, materials, coatings, or prestressing mechanisms (for example, bolt versus nut; head configuration).

4.4.1.1 Determine the pretensioning forces in the anchors of different production methods, materials, coatings, or prestressing mechanisms according to the procedure of Section 9.7.2 at $0.5 T_{inst}$ and T_{inst} of the anchors of the same diameters and embedments. The torques may be different to give the same pretensioning force.

4.4.1.2 Requirement—Reference and shear tests (Test 1, 2, and 14 of Table 4.1; Test 1, 2, 3, 4, 17 and optionally 18 and 19 of Table 4.2; and Test 1, 2 and 12 of Table 4.3) shall be performed on the anchors of different production methods, materials, coatings, or prestressing mechanisms and shall show statistical equivalency to the original product.

4.4.1.3 Requirement—Reliability and service condition tests may be omitted if **all** the following conditions are met:

4.4.1.3.1 Prestressing forces at $0.5 T_{inst}$ and $1.0 T_{inst}$ are statistically equivalent;

4.4.1.3.2 The geometry of the anchors is identical except for head configuration:

4.4.1.3.3 For torque—controlled expansion anchors, the friction between cone and sleeve (internal friction) and the friction between sleeve and concrete (external friction) are identical. This condition shall be considered to be fulfilled if the anchors are made out of the same material, any coatings are the same, and the surface roughness and hardness of the cone and the sleeve are statistically equivalent. In addition, for anchors made out of different materials (e. g. galvanized and corrosion resistant steel) the internal friction between cone and sleeve will mainly depend on a coating.

4.4.1.3.4 For displacement-controlled expansion anchors, the degree of expansion of partial and reference expansion are statistically equivalent

4.4.1.3.5 For undercut anchors, the undercut of the concrete shall be identical in both models for full and partial expansion. In addition, an undercut anchor that gives a follow-up expansion during loading shall comply with the requirements for torque-controlled expansion anchors in Section 4.4.1.3.3.

4.4.1.4 If the requirements of Section 4.4.1.2 and 4.4.1.3 are not met, test the anchors of different production methods, materials, coatings, or prestressing mechanisms in accordance with Table 4.1, 4.2 or 4.3.

4.4.2 Test for determining equivalence of screw anchors of different production methods, materials, or coatings.

ACCEPTANCE CRITERIA FOR MECHANICAL ANCHORS IN CONCRETE ELEMENTS (AC193)

4.4.2.1 For screw anchors of different production methods, materials, or coatings, establish a maximum setting torque, T_{screw} . Perform testing in accordance with the procedures of Section 8.8, on anchors of the same diameters and embedments.

4.4.2.2 Requirement—Maximum setting torque, T_{screw} , shall comply with requirements of Section 8.8.

4.4.2.3 Requirement—Reference and shear tests (Test 1, 2, and 14 of Table 4.1; Test 1, 2, 3, 4, 17 and optionally 18 and 19 of Table 4.2; and Test 1, 2, 3 and 12 of Table 4.3) shall be performed on the screw anchors of different production methods, materials, or coatings and shall show statistical equivalency to the original product. Additionally, the tests for reliability of screw anchors for brittle failure (Table 4.1 Test 8, Table 4.2, Test 11 and Test 8, Table 4.3) and reliability under repeated load (Table 4.1, Test 7 and Table 4.2, Test 10) shall be performed.

4.4.2.4 If the requirements of Section 4.4.2.2 and 4.4.2.3 are not met, test the screw anchors of different production methods, material, or coatings in accordance with Table 4.1 or 4.2.

5.1.3 (2006 IBC only) *Concrete strength*—Test anchors in test members cast of concrete within two nominal compressive strength ranges, based on compressive strength specimens prepared and tested in accordance with ASTM C 31 and ASTM C 39 (see Appendix A3.3.1). The compressive strength of the cylinders shall be within these ranges:

Low-strength concrete: 2,500 to 4,000 psi (17 to 28 MPa);
High-strength concrete: 6,500 to 8,500 psi (45 to 60 MPa).

5.2.1.1 Install anchors according to the manufacturer's instructions, except as otherwise prescribed in ACI 355.2. Report any deviations. The verification of alternative hole drilling methods such as diamond core drilling shall be in accordance with Section 5.2.4.

5.2.3.2.1 For the reliability tests performed with reduced installation effort (Table 4.1, Test 4, Table 4.2, Test 6 and Table 4.3, Test 4), install and set the anchor with a setting torque of $0.5 T_{inst}$. Do not reduce the torque from this amount.

5.2.3.3.1 *Partial expansion*—Set a minimum of five anchors using the weight and number of drops from Table 5.5 for partial expansion. For each anchor, measure the depth of the plug from the upper end of the anchor. Calculate the average depth of the plug for the set anchors. Modify (shorten) the manufacturer's setting tool to provide the calculated setting depth. Use this setting tool for Table 4.1, Test 4, Table 4.2, Test 6 and Table 4.3, Test 4.

5.2.3.3.2 *Reference expansion*—Prepare a setting tool for tests 5, 6 and 7 of table 4.1, Test 7, 8 and 9 of Table 4.2, or Tests 5, 6, and 7 of Table 4.3 using the same method described in 5.2.3.1, but using the number of drops for evaluation of reference expansion from Table 5.5.

5.2.3.4 *Setting of undercut anchors*—Install undercut anchors as specified in Table 5.6. Table 5.6 provides for combinations of parameters for various undercut anchor types. In other tests prescribed in Tables 4.1, 4.2 and 4.3, drill a cylindrical hole with a diameter as given in Tables 4.1, 4.2 and 4.3 and produce the undercut as per manufacturer's instructions. In tests Table 4.1 Test 4, Table 4.2 Test 6, and Table 4.3 Test 4 set undercut anchors using a combination of the specified setting tolerance that produces the minimum bearing surface in the concrete.

5.2.3.5 – *Setting of screw anchors*

5.2.3.5.1 Permitted setting methods for screw anchors shall be defined by the manufacturer. For those systems that are to be set with a torque wrench, the installation torque T_{screw} shall be specified. For those systems set with a machine (impact screw driver, other), the type of machine and maximum power output rating shall be specified. Alternately, the characteristics of acceptable machines in terms of power output shall be specified.

5.2.3.5.2 For all tests in Table 4.1, Tables 4.2 and 4.3 (except Tests 9, 10, and 11 in Table 4.1 and Tests 12, 13, and 14 in Table 4.2 and Test 9, 10 and 11 in Table 4.3), install the screw anchor until the head just contacts the fixture and the fixture can no longer be moved by hand.

For those systems that may be set with either a specified installation torque or with a machine, the anchors shall be set with a torque wrench and the specified installation torque, T_{screw} , shall not be exceeded. If upon the application of the specified installation torque the fixture remains loose, the specified installation torque, T_{screw} , shall either be re-established at a higher level until this condition is satisfied or the anchor shall be deemed unsuitable. For those systems set with a range of machines that satisfy a maximum power output rating specified by the manufacturer, an impact screw driver with maximum power output specified in the manufacturer's installation instructions for the anchor size shall be used. The test laboratory shall select the screw driver with maximum power output for this application from the screw drivers on the market fulfilling the specifications of

ACCEPTANCE CRITERIA FOR MECHANICAL ANCHORS IN CONCRETE ELEMENTS (AC193)

the anchor manufacturer based on its experience or the results of the pre-tests. Following installation of the anchor in accordance with the manufacturers published installation instructions, the fixture shall be checked by hand to determine that it is not loose.

5.2.4 Alternative drilling methods—The qualification of the anchor for installation with drilling methods other than carbide hammer-drilling shall be predicated on fulfillment of the following requirements.

5.2.4.1 Tests—Perform supplemental tests in accordance with Table 5.8 using the alternative drilling method. Install anchors in accordance with the manufacturer's published installation instructions.

5.2.4.2 Requirements—The results of supplemental tests are required in Section 5.2.4.1 shall be shown to be statistically equivalent to the results of corresponding tests conducted with carbide hammer-drill bits in accordance with this criteria. If this requirement is not met, recognition of the alternate drilling method is dependent on the successful completion of all tests as described in ACI 355.2 with the exception of Test No. 14 in Table 4.1 Test No. 17 in Table 4.2 and Test 12 in Table 4.3.

5.5.1.1 To be acceptable, the tensile load-displacement behavior of single anchors shall be predictable except as noted in 5.5.1.2. Figure 5.2 provides examples of acceptable and unacceptable load-displacement curves for the types of anchors covered by ACI 355.2. For each anchor tested, a load plateau with a corresponding slip greater than 5% of the displacement at ultimate load, or a temporary drop in load, is not acceptable at load levels less than N_1 . For tests in uncracked concrete, N_1 is taken as the smaller of $0.8N_u$ and $A_{se} f_y$. For tests in cracked concrete, N_1 is taken as the smaller of $0.7N_u$ and $A_{se} f_y$. These requirements shall be fulfilled in the reference tests (Tests 1 and 2 of Table 4.1 and Tests 1, 2, 3 and 4 of Table 4.2), reliability tests (Tests 4, 5, 6, the initial loading and residual capacity of Test 7 and the residual capacity of Test 8, Method A of Table 4.1 and Tests 6, 7, 8, the residual capacity of Test 9, the initial loading and residual capacity of Test 10 and the residual capacity of Test 11, Method A of Table 4.2), and service condition tests (Tests 12 and 13 of Table 4.1 and Tests 15, 16 and the residual capacity of Test 18 of Table 4.2).

Exception: For anchors qualified exclusively for redundant application to be acceptable, the tensile load displacement behavior of single anchors shall be predictable except as noted in 5.5.1.2. Figure 5.2 provides examples of acceptable and unacceptable load-displacement curves for the types of anchors within the scope of ACI 355.2. For each anchor tested, a load plateau with a corresponding slip greater than 5% of the displacement at ultimate load, or a temporary drop in load, is not acceptable at load levels less than N_1 . For test in uncracked and cracked concrete, N_1 is taken as the smaller of $0.4 N_u$ and $A_{se} f_y$. These requirements shall be fulfilled in the reference tests (Test 1 and 2 of Table 4.3), and the reliability test (Test 4, 5, 6 the initial loading and residual capacity of Test 7, and the residual capacity of Test 8, Method A of Table 4.3)

5.5.3 Modes of failure —The failure modes for tension loading are concrete cone failure, steel fracture, pullout or pull-through, test member splitting, and side-face blowout. The failure modes for shear loading are steel failure and concrete breakout for anchors located near an edge. Figures 5.3 and 5.4 give examples of these failure modes. Report the failure mode for each individual anchor tested and the strength (k values for concrete, $f_{u, test}$ for steel failure, and N_p for pull out and pull-through failure) for each test series.

If during a test series different failure modes occur, and one failure mode predominates and other failure modes occur, and are of similar capacities, note the failure modes and failure loads of the test in the test report. Report the average failure load, taking into account all results as the failure load associated with the predominate failure mode.

If no failure mode predominates in a test, test additional anchors to obtain at least five samples for each failure mode and conduct a significant difference test to see if the capacities for the different failure modes are statistically different.

Exception: For anchors qualified exclusively for redundant applications, refer to Section 5.5.4

5.5.3.1 If an anchor of a particular diameter has only one embedment depth, then tests are performed to establish the appropriate data. If steel failure is the only failure mode report $f_{u, test}$ for steel failure, and report the minimum permissible k value for concrete from Table 7.1. Alternatively, to determine k for concrete failure, it shall be permitted to use a shallower embedment depth or a higher-strength steel bolt, as long as it does not affect the functioning of the anchor.

Exception: For anchors qualified exclusively for redundant applications, refer to Section 5.5.4.

5.5.3.2 If there is more than one embedment depth specified for an anchor diameter, perform tests according to Table 5.7. Report the respective failure modes and the lowest k value for concrete failure, $f_{u, test}$ for steel failure, and N_p for pullout and pull-through failure. Where different failure modes occur in a test series involving a single diameter and different embedment depths, report each observed failure mode and its corresponding characteristic strength.

ACCEPTANCE CRITERIA FOR MECHANICAL ANCHORS IN CONCRETE ELEMENTS (AC193)

Exception: For anchors qualified exclusively for redundant applications, if there is more than one embedment depth specified for an anchor diameter, perform tests according to Table 5.7. Refer to Section 5.5.4 for additional requirements.

5.5.4 For anchors qualified exclusively for redundant – The possible failure modes for tension loading are concrete cone failure, steel fracture, pullout or pull-through, test member splitting, or side-face blowout. The possible failure modes for shear loading are steel failure and concrete breakout for anchors located near an edge. Figures 5.3 and 5.4 provide examples of these failure modes. Report the failure mode for each individual anchor tested and the strength (N_{ra} for tension loading and V_{ra} for shear loading) for each test series.

TABLE 5.7 — REQUIRED EMBEDMENT DEPTHS FOR TEST PROGRAM

Embedment depth to be tested for given diameter	Test number for embedment depths		
	Shallow	Deep	All
Table 4.1	3, 4, 5, 6, 7, 8, 9, 10, 12, 13, 14, 15	3, 4, 5, 6, 7, 8, 11, 12	1, 2
Table 4.2	5, 6, 7, 8, 9, 10, 11, 12, 13, 15, 16, 17, 18, 19, 20	5, 6, 7, 8, 9, 10, 11, 14, 15, 18, 19	1, 2, 3, 4, 20, 21
Table 4.3	3, 4, 5, 6, 7, 8, 9, 10, 12	3, 4, 5, 6, 7, 8, 11	1, 2

TABLE 5.8—REQUIRED SUPPLEMENTAL TESTS FOR EACH ALTERNATIVE DRILLING METHOD

Table	Table 4.1 and 4.3*	Table 4.2†
Test Nos.	1,2,4,5, and 6	1,2,3,4,6,7, and 8

*If the tolerances on the bit diameter do not exceed the limiting values given in Table 5.9, Tests 5 and 6 may be omitted.

†Tests 7 and 8 may be conducted with a standard core drill bit diameter (medium) if the tolerances on the core drill bit diameter do not exceed the limiting values given in Table 5.9.

TABLE 5.9—CORE DRILL BIT LIMITING TOLERANCES

BIT DIAMETER		UPPER LIMIT ON TOLERANCE	
in.	mm	in.	mm.
$< \frac{3}{4}$	< 18	0.004	0.1
$\frac{7}{8} - 1\frac{1}{4}$	20 - 30	0.06	0.15
$> 1\frac{1}{4}$	> 30	0.008	0.2

6.3.4 Length identification—Every anchor, if available for installation in more than one length per anchor diameter, shall be marked with the actual numerical length or with a length code according to Table 6.1 that is visible and legible after installation.

TABLE 6.1—LENGTH IDENTIFICATION CODES

LENGTH CODE		LENGTH OF ANCHOR	
		in.	mm
A	Black	1½ < 2	38 < 51
B	White	2 < 2½	51 < 63
C	Red	2½ < 3	63 < 76
D	Green	3 < 3½	76 < 89
E	Yellow	3½ < 4	89 < 102
F	Blue or Purple	4 < 4½	102 < 114
G	Brown	4½ < 5	114 < 127
H	Orange	5 < 5½	127 < 140
I		5½ < 6	140 < 152
J		6 < 6½	152 < 165
K		6½ < 7	165 < 178
L		7 < 7½	178 < 191
M		7½ < 8	191 < 203
N		8 < 8½	203 < 216
O		8½ < 9	216 < 229
P		9 < 9½	229 < 241
Q		9½ < 10	241 < 254
R		10 < 11	254 < 267
S		11 < 12	267 < 305
T		12 < 13	305 < 330
U		13 < 14	330 < 366
V		14 < 15	366 < 381
W		15 < 16	381 < 406
X		16 < 17	406 < 432
Y		17 < 18	432 < 457
Z		18 < 19	457 < 483
AA		19 < 20	483 < 508
BB		20 < 21	508 < 533
CC		21 < 22	533 < 559
DD		22 < 23	559 < 584
EE		23 < 24	584 < 610
FF		24 < 25	610 < 635

6.3.5 Durability—When durability specifications (corrosion-resistant coatings or materials) are given by the manufacturer, the anchors shall be tested for conformance to the specified standards.

6.3.6 Classification of Anchor Steel as Ductile or Brittle—Elongation and reduction of area shall be determined according to a recognized standard and reported on the data sheet (Chapter 11). If the elongation is at least 14 percent and the reduction of area is at least 30 percent, the anchor shall be considered to meet the ductile steel requirements. If the ductility and reduction of area cannot be determined, the anchor shall be reported as brittle in the report.

Exception: For anchors qualified exclusively for redundant applications, this section does not apply.

7.1 — Purpose

Reference tests are performed to obtain baseline values for the reliability of service-conditions tests. The reference test requirements are given in 7.2 through 7.3, and in Table 4.1 for uncracked concrete, Table 4.2 for both cracked and uncracked concrete, and Table 4.3 for anchors qualified exclusively for redundant applications in cracked concrete. The results...(balance unchanged)

7.2— Reference tension test for single anchors without spacing and edge effects (**Table 4.1, Tests 1, 2, and 3, Table 4.2, Test 1, 2, 3, 4 and 5, or Table 4.3, Tests 1, 2 and 3.**)

7.2.1 Requirements for reference tests—Perform tension tests in accordance with Table 4.1, Tests 1, 2 and 3, Table 4.2, Tests 1, 2, 3, 4 and 5, or Table 4.3 Test 1, 2 and 3. Perform the tests on anchors installed in low-strength and high-strength concrete. The coefficient of variation *v* of the ultimate tension load in any test series, including those performed with an increased number of replicates, shall not exceed 15%. If the coefficient of variation obtained from the original or cumulative test series does not meet this requirement, the sample size shall be permitted to be increased. If this requirement is not met, the anchor shall be considered unqualified.

7.2.2 Requirements for confined reference tests—Confined tests are specified primarily to ensure steel or pull-out failure. Figure 7.1 shows a typical confined tension test setup for concrete screws, whereby the reaction force is transferred into concrete in close proximity to the anchor element. The diameter of the hole in the fixture, *d_f*, shall be $1.5d_o \leq d_f \leq 2d_o$ where *d_o* is the outside diameter of the threads (see Figure 8.3). To reduce the confinement of the concrete by friction, a sheet of tetrafluoroethylene (TFE), polytetrafluoroethylene (PTFE), fluorinated ethylene propylene (FEP) or perfluoroalkoxy (PFA) of

ACCEPTANCE CRITERIA FOR MECHANICAL ANCHORS IN CONCRETE ELEMENTS (AC193)

0.020 +/- 0.004 inches (0.5 +/- 0.1 mm) corresponding to the area of the fixture shall be placed between the fixture and the concrete surface. The thickness of the fixture, t_{pl} , shall be the greater of $3/8$ inch (10 mm) or $d_o/2$.

7.3—Required calculations using results of reference tests

7.3.1 For concrete failure—It shall be permitted to use the mean value of test results $F_{u,test,i}$ for establishment of the effectiveness factor k using Eq. (7-1) and Table 7.1. The results of reference tests in low- and high-strength concrete, normalized to a common compressive strength according to A1.2, shall be permitted to be considered together in establishing $F_{u,test,i}$.

$$k_m = \frac{F_{u,test,i}}{\beta \cdot h_{ef}^{1.5} \sqrt{f_{c,test,i}}} \tag{7-1}$$

where:

- k_m = mean effectiveness factor for use with Table 7.1;
- β = $1 - \frac{0.19}{\sqrt{n}}$ = conversion factor corresponding to a one-sided 10% probability of exceedence at 90% confidence and a coefficient of variation of the base population $v = 15\%$
- n = number of replicates in the test series being considered
- $F_{u,test,i}$ = mean value of test results

If the calculated k values are less than the minimum permissible values of Table 7.1, determine the characteristic tension resistance in accordance with Section 7.3.3.

Exception: Anchors qualified exclusively for redundant applications, shall comply with 7.3.4.

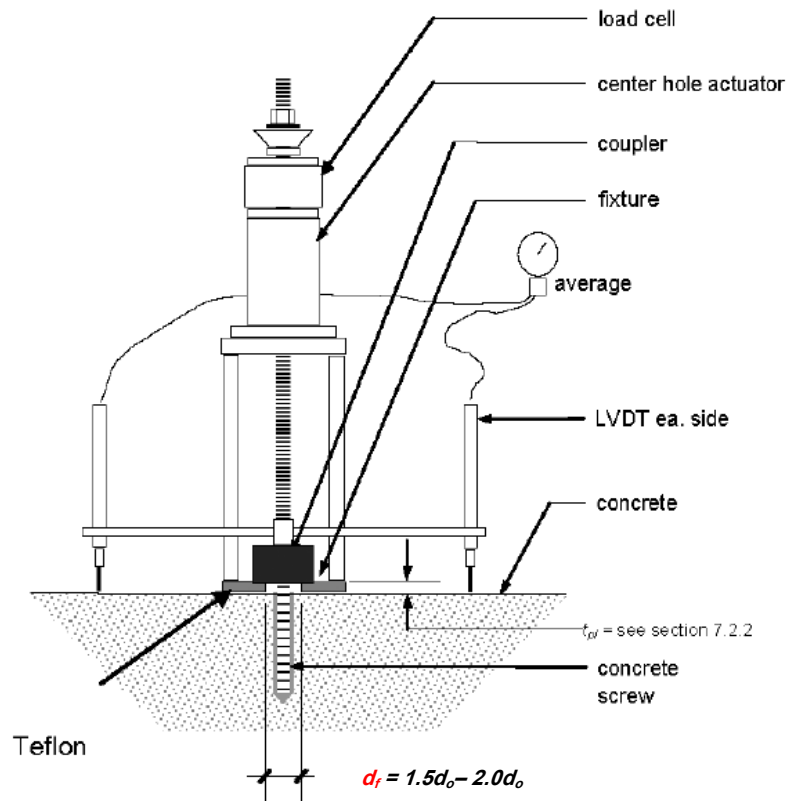

FIGURE 7.1—EXAMPLE OF CONFINED TENSION TEST SETUP FOR CONCRETE SCREWS

TABLE 7.1—MINIMUM AND MAXIMUM VALUES OF EFFECTIVENESS FACTOR, k_m

Type of Test	Permissible range of calculated effectiveness factor k_m		Value of k to be reported in Tables 11.2 or 11.2	
	inch-pound	SI	inch pound	SI
Cracked concrete k_{cr}	$22.5 \leq k_m < 32$ $k_m \geq 32$	$9.5 \leq k_m < 13.5$ $k_m \geq 13.5$	17 24	7 10
Uncracked concrete k_{uncr}	$32.0 \leq k_m < 40.0$ $k_m \geq 40.0$	$13.5 \leq k_m < 16.5$ $k_m \geq 16.5$	24 30	10 12.5

7.3.2 For steel failure in tension, cracked and uncracked concrete—When steel failure occurs for the embedment and steel strength reported in Table 11.1 or 11.2, as applicable, the k -values shall be permitted to be calculated according to Section 7.3.1 for the concrete compressive strength of the test series using the mean failure load. The k -value reported shall not be less than the minimum permissible k -value in Table 7.1. Alternatively, $N_{b,m,i}$ shall be permitted to be established using tests on the same anchor with a reduced embedment, a higher-strength steel, or both, to produce failure by concrete breakout.

Exception: For anchors qualified exclusively for redundant applications, shall comply with 7.3.4.

7.3.3 For pullout failure in tension, cracked and uncracked concrete—For pullout or pull-through failures, calculate the characteristic tensile capacity, N_p , using the test data in accordance with the procedure in Appendix A2, report N_p , and use k = the minimum permissible value of k in Table 7.1.

Exception: For anchors qualified exclusively for redundant applications, shall comply with 7.3.4.

ACCEPTANCE CRITERIA FOR MECHANICAL ANCHORS IN CONCRETE ELEMENTS (AC193)

7.3.4 For anchors qualified exclusively for redundant applications, for all failure modes (concrete failure, steel failure, pull out failure or pull-through failure) — Calculate the characteristic tensile capacity, N_{ra} using the data in accordance with the procedure in Appendix A1 and A2 and report N_{ra} .

8.1 — Purpose

Reliability tests are performed to establish that the anchor is capable of safe, effective behavior under normal and adverse conditions, both during installation and in service. The reliability test requirements for uncracked concrete (Table 4.1) and both cracked and uncracked concrete (Table 4.2) are given in this chapter. The reliability test requirements for anchors qualified exclusively for redundant applications (Table 4.3) are also given in this Chapter. The results of the reliability tests shall be used to establish the anchor category in accordance with Chapter 10.

8.2 Reliability testing using reduced installation in effort (Table 4.1, Test 4 and Table 4.2, Test 6 and Table 4.3, Test 4).

8.2.1 Purpose—These reliability tests determine the sensitivity of the anchor to adverse installation conditions. Perform these tests under tension loading. These tests do not apply to screw anchors.

8.2.2 General test conditions— In cracked concrete, use a minimum crack-opening width of 0.012 in. (0.3 mm)

Exception: For anchors qualified exclusively for redundant applications, use a minimum crack opening width of 0.008 in. (0.2 mm).

8.3 – Reliability in low-strength concrete with large drill bit (Table 4.1, Test 5 and Table 4.2, Test 7 and Table 4.3 Test 5).

8.3.1 Purpose — These reliability tests are performed in uncracked concrete (Table 4.1) to evaluate the sensitivity of the anchor to low-strength concrete and oversized holes. They are performed in cracked concrete (Table 4.2 or Table 4.3) to evaluate the sensitivity of the anchor to low-strength concrete, oversized holes and opened cracks.

8.3.2 General test conditions— Perform tests under tension loading in low-strength concrete for all anchor types with a drill bit of diameter d_{max} . For anchor tests in cracked concrete, use a minimum crack-opening width of 0.020 in. (0.5 mm). The anchor capacity determined in this test series shall be used to establish the anchor category according to Chapter 10.

Exception: For anchors qualified exclusively for redundant applications, use a minimum crack opening width of 0.014 in. (0.35 mm).

8.4 – Reliability in high-strength concrete with small drill bit (Table 4.1, Test 6 and Table 4.2, Test 8 and Table 4.3, Test 6).

8.4.2 General test conditions— Perform tests under tension loading in high-strength concrete for all anchor types. Use a drill bit of diameter d_{min} . In cracked concrete tests, use a minimum crack-opening width of 0.020 in. (0.5 mm). The anchor capacity as determined in this test series shall be used to establish the anchor category according to Chapter 10.

Exception: For anchors qualified exclusively for redundant applications, use a minimum crack opening width of 0.014 in. (0.35 mm).

8.5 – Reliability under repeated load (Table 4.1, Test 7 and Table 4.2, Test 10 for Screw Anchors and Table 4.3, Test 7).

8.5.2.1 Installation of screw anchors—Set the screw anchor on an beveled washer (inclination angle $\geq 4^\circ$, hardness \geq HRC 38, fixture hole oversize $\leq 1/8"$) Install the screw anchor in accordance with 5.2.3.5.2. The most adverse head style shall be identified and tested by the agency. The point of maximum dimension of the head shall contact the beveled washer. In cases where the product geometry includes a fillet under the anchor head or where the head is countersunk, the bevel washer shall be modified such that the fillet shall not be in contact with the bevel washer (see Fig. 8.2).

The position is shown in Figure 8.3. Following anchor installation, the screw anchor head is permitted to either partially contact the beveled washer (see Figure 8.3.a) or in full contact against the washer (see Figure 8.3b). Any position of the anchor head within and including the extreme positions shown in Figure 8.3 shall be acceptable.

ACCEPTANCE CRITERIA FOR MECHANICAL ANCHORS IN CONCRETE ELEMENTS (AC193)

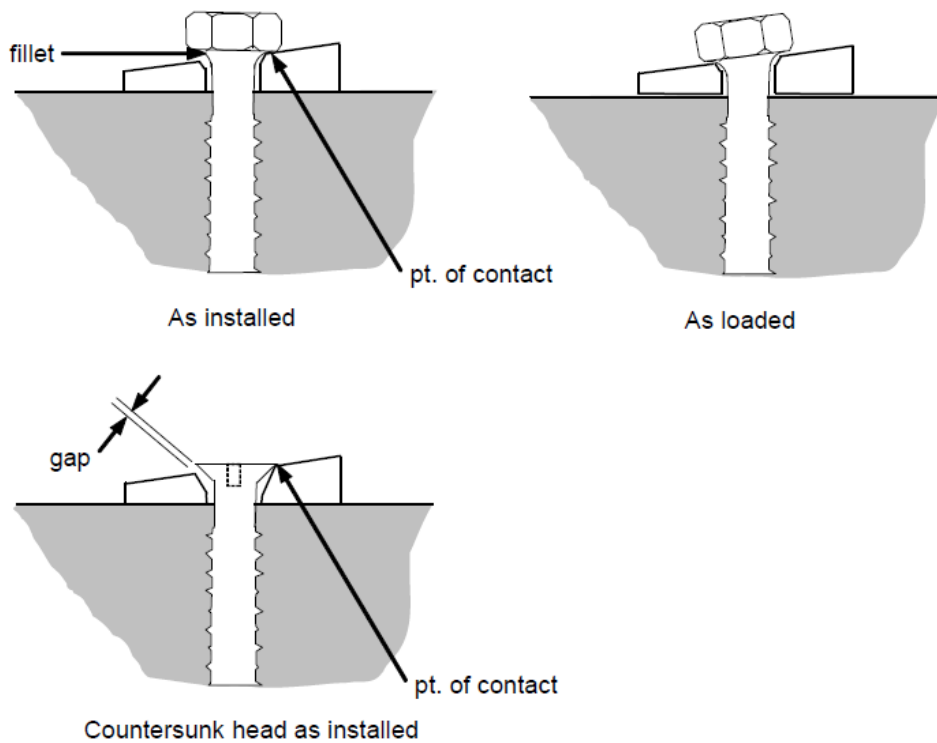

Figure 8.2—BEVEL WASHER GEOMETRY FOR DIFFERENT HEAD SHAPES

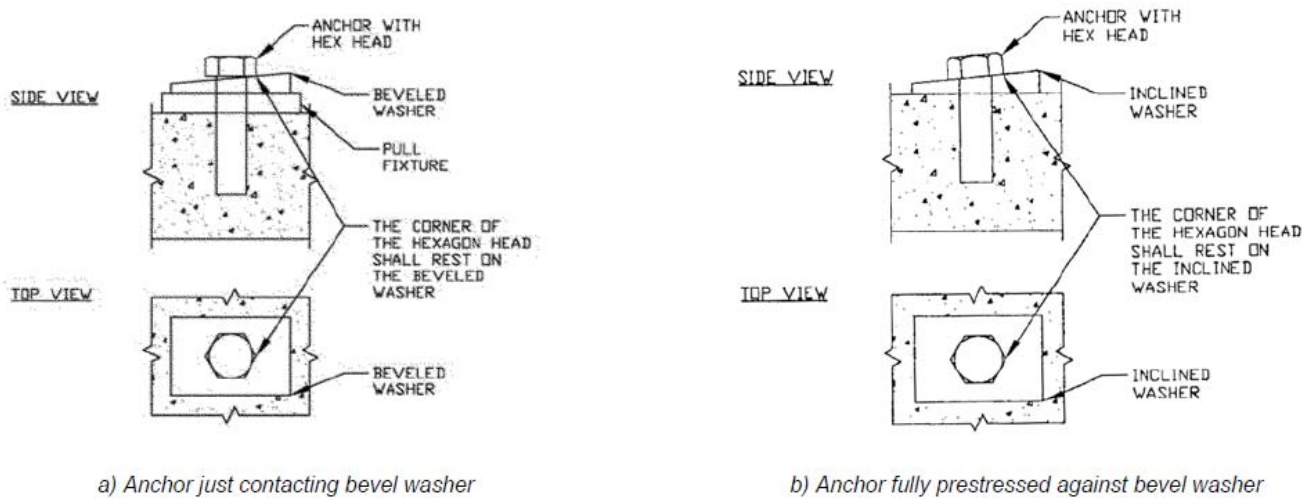

Figure 8.3—ACCEPTABLE POSITION OF THE ANCHOR HEAD IN TESTS WITH REPEATED LOADS

8.5.3 Requirement—Anchor displacements shall show a stabilization of movement. The coefficient of variation, v , of the ultimate tension load in any test series shall not exceed 20 percent. The sample size shall be permitted to be increased if the coefficient of variation of the original sample size does not meet this requirement. If this requirement is not met, the anchor shall be considered unqualified. If this requirement is not met, repeat this test with a reduced maximum load until the condition is met. Then reduce the characteristic pullout, pull-through, or steel capacity in proportion to the reduction in the maximum load.

ACCEPTANCE CRITERIA FOR MECHANICAL ANCHORS IN CONCRETE ELEMENTS (AC193)

8.6—Reliability in cracked concrete where crack width is cycled (Table 4.2, Test 9)

8.6.5 Requirement—In each test, the anchor displacement shall be less than 0.080 in. (2.0 mm) after the initial 20 cycles of crack opening and closing, and less than 0.120 in. (3.0 mm) after 1000 cycles, except as permitted in the following.

If the anchor displacement exceeds these limits during the crack cycling portion of the test, it shall be permitted to increase the number of replicates. For a sample size of 10 to 20 replicates, one of the tested anchors shall be permitted to exhibit a maximum displacement of 0.120 in. (3.0 mm) after the initial 20 cycles and 0.160 in. (4.0 mm) after 1000 cycles. For sample sizes larger than 20, 5% of the tested anchors shall be permitted to exhibit these increased displacements. If the requirements are not met, repeat the tests with a reduced sustained tension load, $N_{w,red}$, on the anchor until the requirements are met. If the tests are performed with a reduced tension load $N_{w,red}$, pullout or pull-through data reported in Table 11.2 shall reflect tests conducted with $N_{w,red}$. The characteristic capacity N_p shall be calculated by Eq. (8-2).

$$N_p = \frac{N_{w,red}}{0.3} \sqrt{\frac{f'_c}{f'_{c,test}}} \quad (8-2)$$

where

N_p = characteristic pullout or pull-through capacity to be reported in Table 11.2;
 $N_{w,red}$ = reduced static tension load applied to anchor during crack cycling portion of test

The characteristic residual tension capacity, $N_{b,r}$, shall be evaluated from the peak loads recorded in the tension tests conducted subsequent to crack cycling as per Section 8.6.4, and shall be used in establishing the anchor category as described in Chapter 10. The coefficient of variation, v , of the ultimate tension loads recorded in any test series shall not exceed 20%. The number of replicates may be increased to meet this requirement. If this requirement is not met, the anchor shall be reported as unqualified for cracked concrete.

8.7—Reliability of screw anchors for brittle failure (Table 4.1 Test 8 and Table 4.2, Test 11 and Table 4.3, Test 8)

8.7.1 Purpose—These reliability tests are intended to verify sufficient insensitivity to stress-induced hydrogen embrittlement cracking under conditions as may occur in service. This test series is not required for anchors fulfilling the requirements of 8.7.1.1.

8.7.1.1 Pre-qualified concrete screw anchors—Anchor diameters meeting all three items A, B, and C over the entire length of the fastener excluding the length h_s (see Figure 8.4) are not sensitive to brittle failure and therefore do not have to be tested:

- A. Core hardness \leq 36 HRC
- B. Case hardness \leq 55 HRC
- C. Case depth \leq 0.02 inches (0.5 mm). Case depth is defined as the depth within the cross section with hardness $>$ 36 HRC.

Note: The above given values for hardness and case depth represent upper tolerance limits in manufacturing drawings.

To check whether these conditions are fulfilled, measurements shall be performed at least directly below the head, at a distance h_s from the tip of the concrete screw and in the middle between those 2 points (see Figure 8.4) on 3 samples per diameter and length from each manufacturing process, material, coating and design.

The core hardness shall be measured at a depth of 0.020 inches (0.5 mm) from the shank surface, and the case hardness at least at a depth of 0.002 and 0.010 inch (0.05 and 0.25 mm) from the shank surface, see Figure 8.5.

Hardness readings shall be determined using a microhardness indenter (such as Vickers or Knoop) and converted to the Rockwell C scale in accordance with reference ASTM A 370.

8.7.2 General test conditions—Where tests in concrete are required, concrete screws shall be installed in an uncracked high strength concrete specimen having a minimum compressive strength of 7,500 psi (51.7 MPa) in accordance with the manufacturer's instructions. Where steel failure occurs in the reference tests, the concrete strength corresponding to those tests may be used.

8.7.2.1 Concrete screw anchors with axially uniform hardness properties—Testing of concrete screw anchors with axially uniform hardness properties shall be done in accordance with Method A and Method B. Test specimens shall have a core hardness equal to the upper limit of the specified hardness range with a tolerance of $+0/-2$ HRC.

In accordance with the Method B requirements of Section 8.7.2.2.3, perform the required number of tests on all diameters from each manufacturing process, material, coating, and design.

ACCEPTANCE CRITERIA FOR MECHANICAL ANCHORS IN CONCRETE ELEMENTS (AC193)

8.7.2.2 Concrete screw anchors with axially nonuniform hardness properties—Testing of concrete screw anchors with axially nonuniform hardness properties shall be done in accordance with Method A and Method B. Test specimens shall have a core hardness equal to the upper limit of the specified hardness range with a tolerance of +0/-2 HRC.

8.7.2.2.1 Method A

Perform 5 tests on all diameters from each manufacturing process, material, coating, and design. Tests shall be conducted at shallow (min h_{nom}) and deep embedments (max h_{nom}) per diameter. For concrete screws with different head forms, anchors with the most adverse head form shall be tested. If the most adverse head form cannot be readily identified, tests with different head forms shall be performed.

8.7.2.2.1.1 The borehole shall be drilled with a medium drill bit diameter d_m . The concrete specimen shall be chosen large enough to preclude splitting failure. Alternatively, the specimen can be cast in a steel ring. Only one test per concrete specimen shall be performed at a time unless a concrete specimen is used that can accommodate more than one anchor.

At the concrete screw location, a bottomless container covering an area of at least 15 square inches (9677 mm²) with a height of at least 1 inch (25.4 mm) shall be affixed to the concrete and filled with a saturated calcium hydroxide solution [$C_a(OH)_2$] having a pH = 12.6 ± 0.1 measured at $77^\circ F \pm 2^\circ F$ ($25^\circ C \pm 1^\circ C$). During the test the head of the concrete screw shall be submerged in the fluid. The temperature during the test shall be maintained at $77^\circ F \pm 9^\circ F$ ($23^\circ C \pm 5^\circ C$). Furthermore the pH-value shall be kept constant by measuring the pH value after 5 days. If the pH-value exceeds the tolerance value (as might occur due to interaction with the concrete) the solution shall be replaced.

The material of the counter electrode shall be stainless steel or activated titanium. The reference electrode is defined by its composition. Its accuracy should be controlled by calibration with a new electrode (tolerance ± 20 mV). The tip of the reference electrode should be located at a distance equal to approximately $0.5h_{nom}$ (see Fig. 8.6) from the concrete surface. This can be achieved by a bore hole depth equal to approximately $0.5h_{nom}$. The length of the counter electrode should be equal to approximately h_{nom} . Reference and counter electrode shall be placed in drilled holes with a diameter of approximately $1/16$ inch (1.6 mm) larger than the diameter of the electrode. The reference electrode should be located as close as possible to the concrete screw and not farther away than 6 inches (152 mm). The distance between reference electrode and counter electrode shall not exceed 2 inches (51 mm).

Before testing, coatings of any kind shall be partially removed in shape of a longitudinal strip to allow hydrogen evolution on the steel surface. The concrete screw shall be subjected to a constant tension load $N_{sust,con} = \min\{0.7N_{u,con,mean}, 0.5N_{st,mean}\}$ over a period of minimum 240 hours. $N_{u,con,mean}$ is the average ultimate tensile load of the confined reference tests, multiplied

by
$$\sqrt{\frac{f'_{c,test}}{f'_{c,ref}}}$$

During the duration of the test, a constant electrochemical potential shall be established and shall be held constant with potentiostatic control or by other appropriate means at $-1200 \text{ mV} \pm 20 \text{ mV}$ (SCE) measured against a saturated calomel electrode (SCE). A suggested test setup is shown in Figure 8.7. Other types of electrodes (e.g. Ag/AgCl) may be used with appropriate correction of the potential.

Following the constant load portion of the test, unload the concrete screw and perform a confined tension test to failure ($N_{u,con,res}$) using the test set-up as shown in Fig. 7.1.

8.7.2.2.1.2 Requirements—During the constant load portion of the test (240 hours), no anchor shall fail. The load displacement behavior as observed in the residual tension test shall conform to the requirements of Section 5.5.1.1. The failure load shall be compared to confined reference tension tests. The ratio of the residual failure loads and the reference test results shall be used to establish the anchor category as described in Chapter 10.

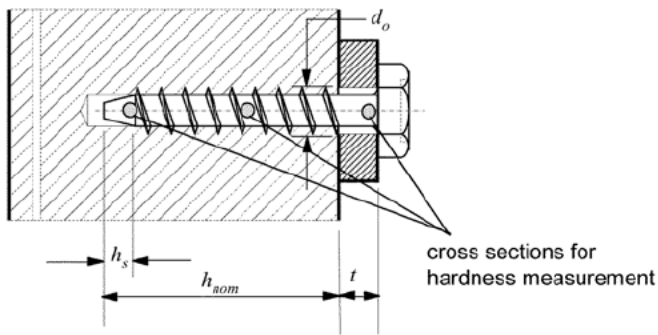

FIGURE 8.4—CONCRETE SCREW WITH SECTIONS FOR HARDNESS MEASUREMENT

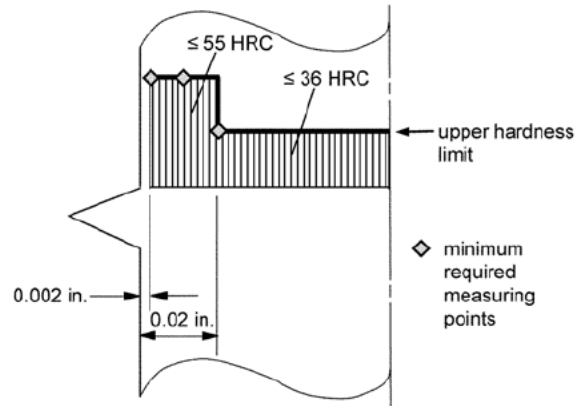

FIGURE 8.5—HARDNESS CRITERIA UNDER WHICH NO TESTS ARE REQUIRED

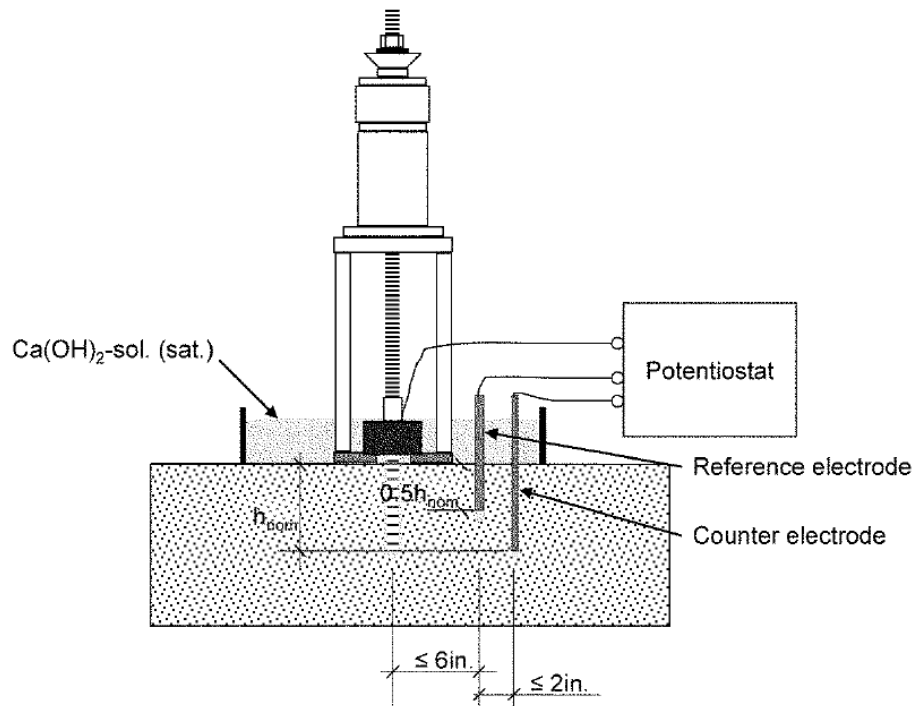

FIGURE 8.6—CONFINED TEST SETUP FOR CHECKING BRITTLENESS OF CONCRETE SCREWS

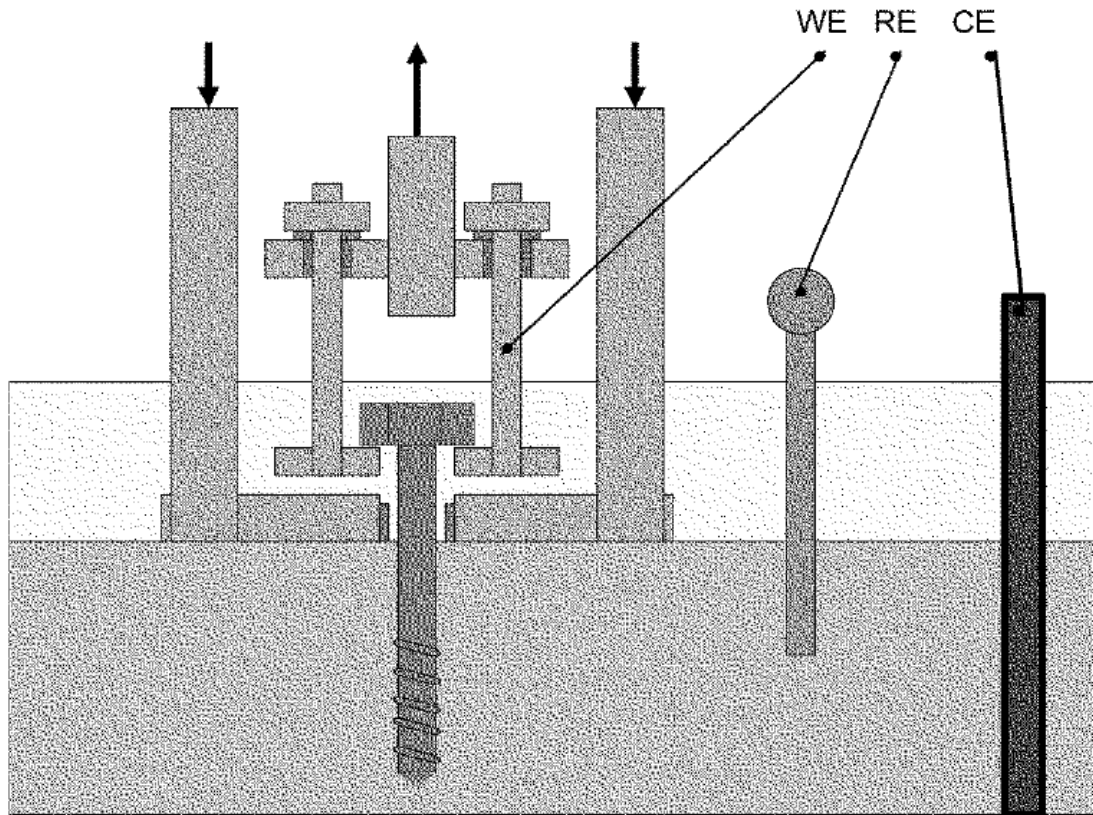

FIGURE 8.7—DETAILS OF ATTACHMENT FOR ANCHOR DURING TEST FOR BRITTLENESS OF CONCRETE SCREWS

8.7.2.2.2—Alternate Method A

In the Alternate Method A, the test is performed as unconfined test with a beveled washer under the anchor head (see Figure 8.8).

8.7.2.2.2.1 The borehole shall be drilled with a medium drill bit diameter d_m . The concrete specimen shall be chosen large enough to preclude splitting failure. Alternatively, the specimen may be cast in a steel ring. Only one test per concrete specimen shall be performed at a time unless a concrete specimen is used that can accommodate more than one anchor.

The screw anchor shall be set on a beveled washer [inclination angle $\geq 4^\circ$, hardness \geq HRC 38, fixture hole oversize $\leq 1/8$ inch (3.2 mm)]. The point of maximum dimension of the head shall contact the beveled washer. The position is shown in Figure 8.2. Following anchor installation, the screw anchor head may either partially contact the beveled washer (see Figure 8.3a) or be in full contact against the washer (see Figure 8.3.b). Any position of the anchor head within and including the extreme positions shown in Figure 8.2 shall be acceptable. For screws with fillets under the head or where the head is a countersunk configuration, see Section 8.5.2.1.

At the concrete screw location, a bottomless container covering an area of at least 15 square inches (9677 mm²) with a height of at least 1 inch (25.4 mm) shall be affixed to the concrete and filled with a saturated calcium hydroxide solution Ca(OH)₂ having a pH = 12.6 \pm 0.1 measured at 77°F \pm 2°F (25°C \pm 1°C). During the test the head of the concrete screw shall be submerged in the fluid. The temperature during the test shall be maintained at 77°F \pm 9°F (25°C \pm 5°C). Furthermore, the pH-value shall be kept constant by measuring the pH value after 5 days. If the pH-value exceeds the tolerance value (as might occur due to interaction with the concrete) the solution shall be replaced.

The material of the counter electrode shall be stainless steel or activated titanium. The reference electrode is defined by its composition. Its accuracy should be controlled by calibration with a new electrode (tolerance ± 20 mV). The tip of the reference electrode should be located at a distance equal to approximately $0.5h_{nom}$ (see Figure 8.8) from the concrete surface. This can be achieved by a bore hole depth equal to approximately $0.5h_{nom}$. The length of the counter electrode should be equal to approximately h_{nom} . Reference and counter electrode shall be placed in drilled holes with a diameter of approximately 1/16 inch (1.6 mm) larger than the diameter of the electrode. The reference electrode should be located as close as possible to the

ACCEPTANCE CRITERIA FOR MECHANICAL ANCHORS IN CONCRETE ELEMENTS (AC193)

concrete screw and not farther away than 6 inches (152 mm). The distance between reference electrode and counter electrode shall not exceed 2 inches (51 mm).

Before testing, coatings of any kind shall be partially removed in shape of a longitudinal strip to allow hydrogen evolution on the steel surface.

The concrete screw shall be subjected to a constant tension load $N_{sust} = \min\{0.7N_{u,mean}; 0.5N_{st,mean}\}$ over a period of 100 hours minimum. $N_{u,mean}$ is the average ultimate tensile load of the reference tests according to Table 4.1, test number 2 or Table 4.2, test number 2 multiplied by

$$\sqrt{\frac{f'_{c,test}}{f'_{c,ref}}}$$

During the duration of the test, a constant electrochemical potential shall be established and shall be held constant with potentiostatic control or by other appropriate means at $-1200 \text{ mV} \pm 20 \text{ mV}$ (SCE) measured against a saturated calomel electrode (SCE). Other types of electrodes (e.g. Ag/AgCl) may be used with appropriate correction of the potential. A suggested test setup is shown in Figure 8.8.

8.7.2.2.2—Requirements—During the constant load portion of the test (100 hours), no anchor shall fail. If concrete failure occurs the test shall be repeated. The load displacement behavior as observed in the residual tension tests shall conform to the requirements of Section 5.5.1.1. The failure load shall be compared to reference tension tests according to Table 4.1, Test 2, Table 4.2, Test 2 or Table 4.3, Test 1. The ratio of the residual failure loads and the reference test results shall be used to establish the anchor category as described in Section 10.

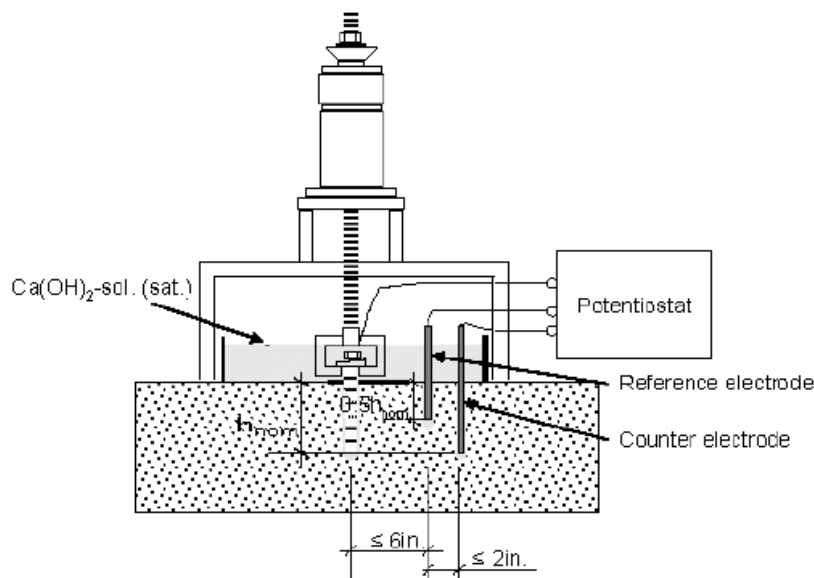

FIGURE 8.8—UNCONFINED TEST SETUP WITH BEVEL WASHER UNDER ANCHOR HEAD FOR CHECKING BRITTLINESS OF CONCRETE SCREWS (METHOD A1)

8.7.2.2.3 Method B

8.7.2.2.3.1 This test method applies to concrete screw anchors that can be loaded in tension or bending during installation and in service. This test method is limited to evaluating hydrogen induced embrittlement due to processing (IHE) and environmental exposure (EHE). This test method is limited to ferrous fasteners that are susceptible to time-delayed fracture caused by the diffusion of hydrogen under stress.

A four-point bend specimen undergoes sustained load and slow strain rate testing by using incremental loads and hold times under displacement control to measure a threshold stress in an accelerated manner in accordance with Test Method ASTM F 1624. The test is an accelerated incrementally increasing step load test method that measures the threshold for hydrogen stress cracking.

ACCEPTANCE CRITERIA FOR MECHANICAL ANCHORS IN CONCRETE ELEMENTS (AC193)

8.7.2.2.3.2 Referenced Documents:

Referenced documents are those contained in Section 2 of ASTM F 1624.

8.7.2.2.3.3 Terminology:

environmental hydrogen embrittlement (EHE)—environment embrittlement caused by hydrogen introduced into steel from external sources.

internal hydrogen embrittlement (IHE)—embrittlement caused by residual hydrogen from processing

FFS (B)—fast fracture strength in air of a fastener specimen in bending, determined in accordance with ASTM E 8.

process—a defined event or sequence of events that may include pretreatments, plating, or coating and post treatments that are being evaluated or qualified.

core threshold —the maximum load at the onset of cracking of the core that is identified by a 5 percent drop in load under displacement control where the test specimen does not continue to maintain the test load to the next two step load levels.

8.7.2.2.3.4 Test Specimens:

The test specimens shall be selected by the testing laboratory and shall be representative of the production fasteners as to base metal, diameter, thread configuration, coating and hardness profile. Test specimens shall have a core hardness equal to the upper limit of the specified hardness range with a tolerance of +0/-2 HRC. A separate series of tests under Method B are not required for different fastener lengths having the same base metal, diameters, thread configurations, coating and hardness profiles.

Specimens shall be ultrasonically cleaned in acetone for 5 to 10 minutes to remove any contaminants such as oils and dirt. Acid cleaning shall not be allowed.

Test specimens shall be cut from the randomly selected samples as shown in Figure 8.9 and such specimens shall be of sufficient length for proper insertion into the gripping devices to achieve the selected four point bending. See Figure 8.10 for an example of a gripping device to achieve the selected four point bending. The cut sample to be tested shall include the portion of the fastener with uniform screw thread configuration but shall exclude the non-threaded portion of the fastener and any case hardened induction zones at the end of the fastener. Before testing, test specimens obtained from fasteners with coatings of any kind shall have the coating removed in the shape of a longitudinal strip and be positioned on the tensile side of the test specimen. The above coating removal shall occur within the space of the minimum two threads as shown in Figure 8.10.

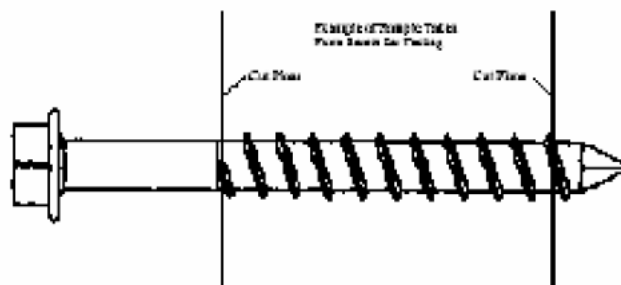

FIGURE 8.9—ILLUSTRATION OF TEST SPECIMEN EXTRACTION

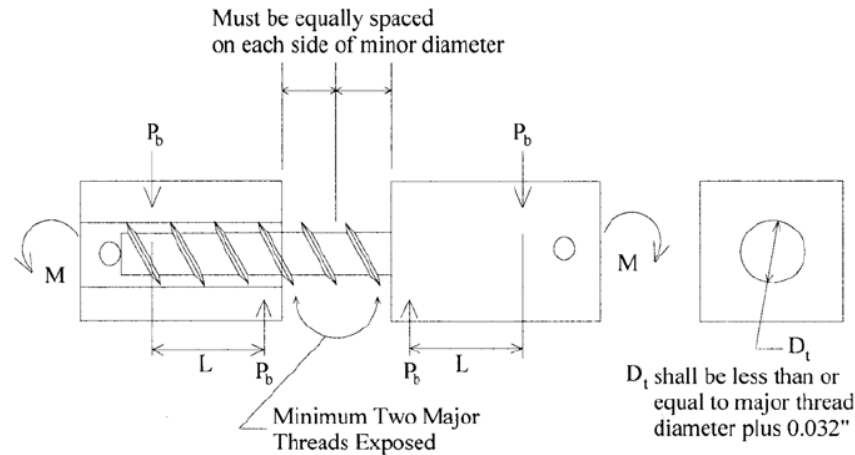

FIGURE 8.10—EXAMPLE OF FOUR POINT LOAD GRIPPING DEVICE

8.7.2.2.3.5 Summary of Test Method:

8.7.2.2.3.5.1 Mandatory Test: Specimens shall be tested in the hydrogen embrittling environmental conditions specified in ASTM F 1624 using the step load procedure of Section 8 of ASTM F 1624 except as modified herein. A minimum of three tests are required as follows:

1. First test is a 20/5/1 (twenty steps in five percent increments with a 1-hour hold for each step).
2. Second test is a 10/5/2 (first ten steps of the test), followed by a 10/5/4 (second ten steps of the test). Loading is not released during the transition from the 2-hour to 4-hour hold requirement.
3. Third test is a repeat of the second test.

If an invariant value within 5 percent is obtained in two consecutive tests as a result of the completion of the three minimum required tests, no further tests are required. Otherwise, additional tests at longer hold times shall be performed until an invariant value within 5 percent is obtained in two consecutive tests. The loading rate shall be slow enough to ensure that a core threshold will be detected if deleterious amounts of hydrogen are present in "worst case" scenario.

The load used for determination of the value of each of the steps (i.e. loads divided by the number of steps) for the first test shall be based on the average value of tensile strength resulting from the three bending (FFS(B) tests in air based upon the minimum diameter cross-section of the fasteners. The load used for determination of the value of each of the steps (i.e. load divided by the number of steps) for each of the subsequent tests shall be 110 percent of the core threshold value determined in the previous test but not more than the load used to establish the steps in the previous test.

The lowest core threshold value established by the two consecutive tests used to meet the invariant value requirement from the hydrogen embrittling environmental conditions test shall be autographically recorded in terms of load versus time and included as part of the report required by Section 8.7.2.2.3.8.

8.7.2.2.3.6 Apparatus:

8.7.2.2.3.6.1 Testing Equipment: Testing equipment shall be within the guidelines of calibration, force range, resolution, and verification of ASTM E 4.

8.7.2.2.3.6.2 Gripping Devices: Various types of gripping devices may be used for the four-point bending to transmit the measured load applied by the testing equipment to the test specimen. Figure 8.10 illustrates an example of a four point gripping device.

8.7.2.2.3.6.3 Test Environment: The test shall be conducted in an aggressive hydrogen producing environment by imposing a cathodic galvanic potential in salt water contained in an appropriate inert container.

8.7.2.2.3.6.3.1 Potentiostatic Control: The corrosion potential of the specimen shall be controlled with a reference Saturated Calomel Electrode (SCE) or equivalent reference electrode such as Ag/AgCl in accordance with ASTM G 5. The imposed potential is cathodic and shall be set at -1.2 ± 0.025 V versus SCE (V_{SCE}) in a 3.5 percent by weight NaCl solution.

8.7.2.2.3.7 Calculations: Calculations shall be in conformance with Section 9 of ASTM F 1624.

ACCEPTANCE CRITERIA FOR MECHANICAL ANCHORS IN CONCRETE ELEMENTS (AC193)

8.7.2.2.3.8 Report: A test report shall be produced in accordance with Section 10 of ASTM F 1624 and shall include the audiographic recordings specified in Section 8.7.2.2.3.5.1.

8.7.2.2.3.9 Conditions of Acceptance: The equivalent tensile load calculated from the lowest core threshold value determined in Section 8.7.2.2.3.5.1 shall be not less than 70 percent of the mean tensile load determined using the confined concrete reference test under Table 4.1, Test 3, Table 4.2, Test 5, or Table 4.3, Test 3 for the maximum embedment depth for which recognition is requested. Such reference test values shall be normalized to 7,500 psi (51.7 MPa) concrete if pullout is the dominant failure mode in the reference test.

Exception: For anchors qualified exclusively for redundant applications, reference test values shall be normalized to 2,500 psi (17.2 MPa) compressive strength concrete if pullout is the dominant failure mode in the reference test.

In order to compensate for variable moments of inertia due to fastener cross-sectional dimensional variations, the comparison of equivalent tensile load shall be based on a c^e/l^e value calculated from the tensile and bending tests of the fasteners outside of an embrittled environment (tested in ambient air).

The c^e/l^e value is calculated using the relationships as follows:

$$\text{Bending Test (air)} \quad f_{b,tensile\ air} = M_{max,air}/l \quad (8-3)$$

The value of $f_{b,tensile\ air}$ used in Eq. 8-3 shall be the average value of three tests.

$$\text{Tension Test (air)} \quad f_{t,tensile\ air} = P_{max\ air}/A \quad (8-4)$$

The value of $f_{t,tensile\ air}$ used in Eq. 8-4 shall be the average value of three tests.

$$\text{Solving for } c^e/l^e \text{ as follows:} \quad c^e/l^e = P_{max\ air}/AM_{max,air} \quad (8-5)$$

The c^e/l^e value thus determined is then used to convert the lowest core threshold value determined under the step loading in Section 8.7.2.2.3.5 into a tensile stress $f_{tensile,environmental}$. This value is then used for conversion to a tensile load $P_{max\ environmental}$ using the same A from Eq. 8-4 for the tension test.

$$f_{tensile,environmental} = M_{max\ environmental} (c^e/l^e) \quad (8-6)$$

$$P_{max\ environmental} = f_{tensile,environmental} (A) \quad (8-7)$$

$$P_{max\ environmental} \geq 0.70 P_{confined\ air} \quad (8-8)$$

where:

- A = the least cross-sectional area of the fastener along the length of the test specimen, in² (mm²).
- c^e/l^e = computed equivalent c/l value based on Eq. 8-5 using the relationships shown in Eq. 8-3 and Eq. 8-4 for bending and tension respectively, in./in⁴ (mm/mm⁴).
- $f_{b,tensile\ air}$ = maximum tensile stress determined from the bending test performed in air (See FFS(B) definition in Section 8.7.2.2.3), psi (MPa).
- $f_{t,tensile\ air}$ = maximum tensile stress determined from the tension test performed in air. (See test required to establish N_u in Section 6.3.2 and Sections 2.1.1.8 and 2.3.6 of AC193, psi (MPa).
- $P_{max\ air}$ = maximum load at failure in the tension test performed in air, lb (N).
- $M_{max,air}$ = maximum moment at failure in the bending test performed in air, lb-in (N-mm).
- $f_{tensile,environmental}$ = maximum tensile stress determined from the bending test performed in embrittling solution, psi (MPa).
- $P_{max\ environmental}$ = maximum tensile load computed based on lowest core threshold value determined in Section 8.7.2.2.3.5, lb (N).
- $M_{max\ environmental}$ = maximum moment computed based on lowest core threshold value determined in Section 8.7.2.2.3.5, lb (N).
- $P_{confined\ air}$ = maximum load determined in the confined tension test in Table 4.1, Test 3, Table 4.2, Test 5 or Table 4.3, Test 3, lb (N).

ACCEPTANCE CRITERIA FOR MECHANICAL ANCHORS IN CONCRETE ELEMENTS (AC193)

8.8—Reliability tests of screw anchors to setting method (Table 4.1, Tests 9, 10 and 11, Table 4.2, Tests 12, 13 and 14, and Table 4.3, Tests 9, 10 and 11)

8.8.1 These reliability tests shall be performed in uncracked concrete to evaluate the setting method of screw anchors with impact screw drivers and torque wrenches in accordance with the following options.

- (i) If an impact screw driver is specified, perform tests according to Section 8.8.2;
- (ii) If a torque wrench is specified, perform tests according to Sections 8.8.3 and 8.8.4;
- (iii) If both an impact screw driver and a torque wrench are specified, perform tests according to Sections 8.8.2, 8.8.3, and 8.8.4.
- (iv) If the manufacturer specifies that a torque-limiting tool shall be used for the installation of the anchor, (Table 4.1, Tests 9, 10 and 11, Table 4.2, Test 12, 13 and 14, and Table 4.3, Tests 9, 10 and 11) shall not be required. A torque limiting tool shall be capable of disengaging from the anchor head within 1 second of the anchor head coming into contact with the test fixture. The independent testing and evaluation agency shall verify that these requirements are met.

8.8.2—Reliability of screw anchors when set with impact screw driver (Table 4.1, Test 10, Table 4.2, Test 13 and Table 4.3, Test 10)

8.8.2.1 *Purpose*—These reliability tests shall be performed to evaluate the setting of screw anchors with impact screw driver tools. The tests shall be performed in uncracked concrete to determine if impact screw drivers can be used to set screw anchors correctly and reliably.

8.8.2.2 *General Conditions*—The tests shall be performed in low-strength uncracked concrete using a drill bit diameter of d_{max} and anchors corresponding to the shallowest embedment for each anchor diameter. An impact screw driver with maximum power output specified in the manufacturer's installation instructions for the anchor size shall be used. The test laboratory shall select the screw driver with maximum power output for this application from the screw drivers on the market fulfilling the specifications of the anchor manufacturer based on its experience or the results of the pre-tests. The manufacturer shall specify whether the product shall be permitted to be loosened and reinstalled with the impact screw driver to facilitate attachment, realignment, etc. If this installation procedure is permitted, tests in accordance with Section 8.8.2.2.3 shall be performed. If this installation procedure is not permitted, tests in accordance with Section 8.8.2.2.4 shall be performed.

8.8.2.2.3 To qualify anchors for re-tightening, perform tests according to one of the following options:

Option A:

1. Install the anchor in accordance with the manufacturer's installation instructions.
2. Back the anchor out of the hole a minimum of one full turn by the method described in the manufacturer's installation instructions.
3. Re-install the anchor with the impact screw driver. The maximum power to the head of the screw anchor shall be applied by the impact screw driver. The screw driver shall be switched off automatically after 5 seconds.

Option B:

1. Install the anchor in accordance with the manufacturer's installation instructions.
2. Back the anchor out of the hole a minimum of one full turn by the method described in the manufacturer's installation instructions.
3. Re-install the anchor with the impact screw driver. The maximum power to the head of the screw anchor shall be applied by the impact screw driver. The screw driver shall be switched off automatically after 3 seconds.
4. Perform separate tests in accordance with Section 8.8.2.2.4.

Option C:

1. Install the anchor in accordance with Section 8.8.2.2.4.
2. Back the anchor out of the hole a minimum of one full turn by the method described in the manufacturer's installation instructions.
3. Re-install the anchor with the impact screw driver. The maximum power to the head of the screw anchor shall be applied by the impact screw driver. The screw driver shall be switched off automatically after 3 seconds.

8.8.2.2.4 For anchors that are not to be qualified for re-tightening, install the anchor until the anchor head contacts the fixture. In tests performed with the stud type version, the anchor shall be supported on the bottom of the drilled hole ($h_{hole} \approx h_{nom}$). The screw driver shall be switched off automatically after 5 seconds.

8.8.2.3 *Requirement*—No anchor failure (steel rupture or concrete failure) shall occur in all tests. Exception: one anchor failure is allowed if the number of tests is doubled. The manufacturer shall specify that the product may not be loosened and re-tightened unless the supplementary tests described in Section 8.8.2.2.3 are successfully completed.

ACCEPTANCE CRITERIA FOR MECHANICAL ANCHORS IN CONCRETE ELEMENTS (AC193)

8.8.3—Reliability of screw anchors when set with a torque wrench in low strength concrete (Table 4.1, Test 10, Table 4.2, Test 13, and Table 4.3, Test 11)

8.8.3.1 Purpose—These reliability tests shall be performed in uncracked concrete to evaluate the sensitivity of the anchor to low-strength concrete when set with a torque wrench.

8.8.3.2 General Test Conditions—Perform tests under torque loading in low-strength concrete for all anchor types. Use a drill bit of diameter d_{max} and anchors corresponding to the shallowest embedment for each anchor diameter. Install the anchor with a calibrated torque wrench. In tests performed with the stud type version the anchor shall be supported on the bottom of the drilled hole ($h_{hole} \approx h_{nom}$). Increase the torque up to failure (steel rupture or concrete failure). Determine the ultimate torque moments of the test series T_u and the 5% fractile of the ultimate torques.

8.8.3.3 Requirements—The maximum torque moment required to set the anchor at the designated setting depth and to achieve full bearing of the head of the screw against the fixture shall not exceed T_{screw} . If upon the application of the specified installation torque the fixture remains loose, the specified installation torque, T_{screw} , shall either be re-established at a higher level until this condition is satisfied or the anchor shall be deemed unsuitable.

Eq. (8-9) and Eq. (8-10) shall be fulfilled. Exception: If in all tests steel failure occurs, Eq. (8-9) may be omitted. If Eq. (8-10) is fulfilled, Eq. (8-9) may be omitted.

Tests with steel failure

$$T_{5\%} \geq 1.4 \cdot \alpha_3 \cdot T_{screw} (f_{u,test}/f_{ut}) \quad (8-9)$$

Tests with concrete failure

$$T_{5\%} \geq 2.0 \cdot \alpha_3 \cdot T_{screw} (f_{c,test}/f_{c,m})^{0.5} \quad (8-10)$$

where:

$T_{5\%}$	=	5% fractile of the ultimate torque moments, T_u
α_3	=	1.0 for $v \leq 15\%$
	=	$1.0 + (v (\%) - 15) \cdot 0.03$ for $15\% < v \leq 30\%$,
v	=	coefficient of variation of ultimate torque moments.
f_{cm}	=	2,500 psi (17.2 MPa) (concrete compression strength to which test results are to be normalized)

8.8.4—Reliability of screw anchors when set with a torque wrench in high-strength concrete – (Table 4.1, Test 11, Table 4.2, Test 14, and Table 4.3, Test 11)

8.8.4.1 Purpose—These reliability tests shall be performed in uncracked concrete to evaluate the sensitivity of the anchor to high-strength concrete when set with a torque wrench.

8.8.4.2 General Test Conditions—Perform tests under torque loading in high-strength concrete for all anchor types. Use a drill bit of diameter d_{min} and the deepest embedment for each diameter. In tests performed with the stud type version the anchor shall be supported on the bottom of the drilled hole ($h_{hole} \approx h_{nom}$). Increase the torque up to failure. Determine the ultimate torque moments of the test series (T_u) and the 5% fractile of the ultimate torque. For anchors that do not fail with the application of 350 ft-lb (475 N-m) of torque, the value of T_u may be taken as 350 ft-lb (475 N-m).

8.8.4.3 Requirements—The maximum torque moment required to set the anchor at the designated setting depth and to achieve full bearing of the head of the screw against the fixture shall not exceed T_{screw} . If upon the application of the specified installation torque the fixture remains loose, the specified installation torque T_{screw} shall either be re-established at a higher level until this condition is satisfied or the anchor shall be deemed unsuitable.

Eq. (8-9) and Eq. (8-10) shall be fulfilled whereby in Eq. (8-10), the value of $f_{c,m}$ shall be taken as 6,500 psi (44.8 MPa).

Exception: If in all tests steel failure occurs Eq. (8-10) may be omitted.

9.1 Purpose and General Conditions

9.1.1 Minimum member thickness—The manufacturer shall specify the minimum member thickness, h_{min} , corresponding to each anchor diameter and embedment depth, subject to fulfillment of the requirements in Sections 9.2 and 9.3. Optionally, h_{min} shall be determined by installation tests described in Section 9.1.2. In no case shall h_{min} be less than the drilled hole depth + Δh whereby $\Delta h = 2 d_0 \geq 1.25$ in. (30 mm).

ACCEPTANCE CRITERIA FOR MECHANICAL ANCHORS IN CONCRETE ELEMENTS (AC193)

Exception: For anchors qualified exclusively for redundant applications, h_{min} shall be greater of $2 h_{ef}$ or 4 inches (102 mm). Section 9.1.2 and 9.1.3 are not applicable.

9.1.2 Optionally, the minimum specified member thickness, h_{min} , shall be permitted to be determined by separate installation tests. A minimum of 10 installation tests shall be performed for the maximum embedment depth, h_{ef} , associated with each anchor diameter to show that drilling of the hole and installation (e.g., setting, torquing) of the anchor do not result in cracking or breakthrough of the concrete member. Each test shall consist of drilling the hole, setting the anchor and inspecting the test specimen for visible concrete cracking or spalling. For the purpose of these tests, the test member (slab, beam) shall be supported with a shear span length (distance from anchor to support) of not less than $1.5 h_{ef}$. Drilling equipment and setting procedures shall be representative of normal anchor installation as specified by the anchor manufacturer.

9.1.3 For values of h_{ef} for which h_{min} has not been determined by tests as described in Section 9.1.2, or by supporting the test member during drilling and anchor installation for the tests as described in Sections 9.2 and 9.3, $h_{min} = 2.0 h_{ef}$ but not less than the drilled hole depth + Δh whereby $\Delta h = 2d_0 \geq 1.25$ in. (30 mm).

9.2 Service-condition tension test with a single anchor with two edges (corner) (Table 4.1, Test 12 and Table 4.2, Test 15)

9.2.1 Purpose—The purpose of this test is to determine whether the anchor meets the requirement that the critical edge distance shall be $\leq 1.5 h_{ef}$, in members having the minimum specified thickness, h_{min} , to be reported for that anchor. Perform tests on single anchors in uncracked, low-strength concrete at a corner with equal edge distances of $1.5 h_{ef}$ and specified test member thickness h_{min} . If $h_{min} < 2.0 h_{ef}$, and separate tests as described in Section 9.1.2 have not been performed to establish h_{min} , the test member (slab or beam) shall be supported with a shear span length (distance from anchor to support) not less than $1.5 h_{ef}$. Drilling equipment and setting procedures shall be representative of normal anchor installation as specified by the manufacturer. Subsequent to drilling the holes and setting the anchors, the balance of tests in accordance with Section 9.2 shall be permitted to be conducted without supports.

9.2.2 Requirements for critical edge distance—Verify that the drilling of the hole and installation (e.g., setting or torquing) of the anchor do not result in cracking or breakthrough of the concrete member. If cracking or breakthrough of the concrete member occurs in any test, it shall be permitted to increase h_{min} and to repeat the tests until no cracking or breakthrough occurs in any test. Furthermore, it shall be verified that the critical edge distance $\leq 1.5 h_{ef}$. The ultimate capacity of the anchor with two edge distances of $1.5 h_{ef}$ shall be statistically equivalent (Section 2.1.12) to the capacity from the reference tests performed away from the edges. For anchors that do not satisfy this requirement, the distance from the two edges shall be increased until the requirement is met. Report the critical edge distance c_{cr} and the corresponding minimum member thickness, h_{min} , in Table 11.1 or 11.2.

9.3 Service condition test at minimum edge distance and minimum spacing (Table 4.1, Test 13 and Table 4.2, Test 16).

9.3.2 General test conditions—Test all diameters of all anchor types in uncracked, low-strength concrete, with a drill bit of diameter d_m . Install two anchors at the minimum spacing s_{min} , and the minimum edge distance c_{min} , in test members with the minimum thickness h_{min} , to be reported for the anchor. Place the two anchors in a line parallel to the edge of a concrete test element at a distance of at least $3 h_{ef}$ from other groups. Select the minimum spacing s_{min} , minimum edge distance c_{min} , and minimum thickness h_{min} , depending on the characteristics of the anchor.

Separate bearing plates shall be permitted to be used for each anchor, to simplify the detection of concrete cracking. The distance to the edge of the bearing plate from the centerline of the corresponding anchor shall be three times the diameter d_o , of the anchor being tested. If $h_{min} < 2.0 h_{ef}$, and separate tests as described in Section 9.1.2 have not been performed to establish h_{min} , the test member (slab, beam) shall be supported with a shear span length (distance from anchor to support) of not less than $1.5 h_{ef}$. Drilling equipment and setting procedures shall be representative of normal anchor installation as specified by the anchor manufacturer. Subsequent to drilling the holes and setting the anchors, the balance of tests in accordance with Section 9.2 shall be permitted to be conducted without supports.

9.3.3 For torque-controlled anchors and for screw anchors that are either set with an impact screw driver or with a torque wrench, torque (balance of section unchanged)

9.3.4 For load-controlled undercut anchors and for screw anchors that are set with an impact screw driver only, install the anchors according to the manufacturer's installation instructions and load the group of two anchors in tension to failure.

9.3.6 Requirement—Verify that the drilling of the hole and installation (e.g. setting or torquing) of the anchor do not result in cracking or breakthrough of the concrete member. If cracking or breakthrough of the concrete member occur in any test, it shall be permitted to increase h_{min} and to repeat the tests until no cracking or breakthrough occurs in any test. For torque-controlled expansion anchors and for screw anchors that are either set with an impact screw driver or with a torque wrench,

ACCEPTANCE CRITERIA FOR MECHANICAL ANCHORS IN CONCRETE ELEMENTS (AC193)

the 5 percent fractile of the maximum recorded torque calculated according to Appendix A2 and normalized to $f'_c = 2,500 \text{ lb/in}^2$ (17.2 MPa) by Eq. A 1.1 shall be larger than the lesser of $1.7 T_{inst}$ or $1.0 T_{inst} + 100 \text{ ft-lb}$ (138 Nm). For screw anchors, T_{inst} shall be replaced by T_{screw} . If this requirement is not met, repeat the tests with increased values for c_{min} and for s_{min} until the requirement is met. For displacement-controlled expansion and undercut anchors, and load-controlled undercut anchors and screw anchors that are set with an impact screw driver only, the edge shall not be damaged during the setting process and the characteristic failure load shall be equal to, or greater than, the characteristic resistance for concrete cone breakout failure calculated according to provisions of ACI 318 Appendix D. If the anchors do not meet these requirements, determine c_{min} and s_{min} according to the following:

- holding c_{min} constant, increase s_{min} , install the anchors according to Sections 9.3.3, 9.3.4 or 9.3.5 until no splitting occurs;
- holding s_{min} constant, increase c_{min} , install the anchors according to Sections 9.3.3, 9.3.4 or 9.3.5 until no splitting occurs, or
- increase c_{min} and s_{min} , install the anchors according to Sections 9.3.3, 9.3.4 or 9.3.5 until no splitting occurs.

Report these minimum edge and spacing distances and the corresponding minimum member thickness h_{min} , in Table 11.1 or 11.2.

9.4 Service-condition shear test for single anchors without spacing and edge effects (Table 4.1, Test 14, Table 4.2, Test 17, and Table 4.3, Test 12)

9.4.1 Purpose—This test is performed to evaluate the shear capacity of anchors. Perform shear tests in uncracked low-strength concrete with a drill bit diameter d_m for all anchor diameters at minimum embedment h_{ef} . At the option of the manufacturer, additional tests shall be permitted to be performed at deeper embedments. Normalize results in accordance with Appendix A1 and calculate V_{st} using Appendix A2. Characteristic shear capacities V_{st} obtained shall be reported in Tables 11.1 and 11.2, where the values are less than those obtained from ACI 318, Appendix D.6.1.2(b) Equation (D-20).

Exception: For anchors qualified exclusively for redundant applications, refer to section 9.4.3

9.4.2 For anchors evaluated according to Table 4.2 in cracked concrete, shear tests shall be performed in cracked concrete with a crack width of 0.012 in. (0.3 mm) with the load applied parallel to the crack. Characteristic shear capacities V_{st} obtained shall be reported in Table 11.2, where the values are less than those obtained from ACI 318, Appendix D.6.1.2 (b) Equation (D-20).

Exception: For anchors qualified exclusively for redundant applications, refer to section 9.4.3

9.4.3 For anchors qualified exclusively for redundant applications, test according to Table 4.3, Test 12 in cracked concrete. Shear tests shall be performed in cracked concrete with a crack width of 0.008 in. (0.2 mm) with the load applied parallel to the crack. Characteristic shear capacities, V_{ra} obtained shall be reported in Table 11.3.

9.5 Service-condition, simulated seismic tension tests (Table 4.2, Test 18)

9.5.1 Purpose—These optional tests are intended to evaluate performance of anchors, subjected to seismic tension loads including effects of concrete cracking. If these seismic tests are performed, they shall only be acceptable as part of the total cracked concrete test program of Table 4.2.

9.5.2 Test each anchor diameter at embedments as specified in Table 5.7. Install the anchor in a closed crack in accordance with Section 5.4.1. If no torque is specified by the manufacturer, finger-tighten the anchor prior to testing. Test internally threaded anchors with the bolt specified by the manufacturer and report the bolt type in Table 11.2. Open the crack by $\Delta w = 0.020 \text{ in.}$ (0.5 mm) where Δw is additive to the initial (hairline) crack width. Subject the anchors to the sinusoidal tension loads specified in Table 9.1 and Fig. 9.1 with a cycling frequency between 0.1 and 2 Hz, whereby N_{eq} , N_m , and N_i are as follows:

$$N_{eq} = 0.5 F_{u,test,3} \sqrt{\frac{f_{c,test,18}}{f_{c,test,3}}} \quad (9-1)$$

where:

- $F_{u,test,3}$ = mean tension capacity in cracked concrete from reference tests (Table 4.2, Test 3);
 $f_{c,test,18}$ = measured compressive strength of the concrete used for the simulated seismic tension tests (Table 4.2, Test 18);

ACCEPTANCE CRITERIA FOR MECHANICAL ANCHORS IN CONCRETE ELEMENTS (AC193)

- $f_{c,test,3}$ = measured compressive strength of the concrete used for the reference tests (Table 4.2, Test 3).
- N_m = one fourth the mean tension capacity in cracked concrete from reference test; and
- N_i = $(N_{eq} + N_m) / 2$

Record the crack width, anchor displacement and applied tension load in accordance with Section 5.4.3.

Following completion of the simulated seismic-tension cycles, open the crack to a width not less than the crack opening width as measured at the end of the cyclic test and load the anchor in tension to failure. Record the maximum tension load (residual tension capacity), the corresponding displacement, and plot the load-displacement response. If the anchor fails before completing the number of cycles required in Table 9.1, record the number of cycles and load at failure.

9.5.3 Requirements—All anchors in a test series shall complete the simulated seismic-tension load history specified in Table 9.1 and Fig. 9.1. Failure of an anchor to develop the required tension resistance in any cycle prior to completing the loading history specified in Table 9.1 and Fig. 9.1 shall be recorded as an unsuccessful test. The mean residual capacity of the anchors in the test series shall be equal to or greater than 160 percent of N_{eq} as given by Eq. (9-1).

Successful completion of the cyclic loading history and fulfillment of the residual tension capacity requirement of this Section shall be reported together with an anchor capacity N_p , equal to the value determined from the static test results in cracked concrete, to be reported in Table 11.2 for use in cases that include earthquake loading. If the pull-out or pull-through failure modes do not predominate in the reference tension tests in cracked concrete (Table 4.2, Tests 3 and 4), the basic concrete breakout strength in tension of a single anchor in cracked concrete, N_b , as determined in accordance with ACI 318 shall be reported, whereby the value of k is determined in accordance with Section 7.3.

If the anchor fails to fulfill the above requirements at N_{eq} , it shall be permitted to conduct the test with reduced cyclic loads conforming to the loading history specified in Table 9.1 and Fig. 9.1 whereby $N_{eq, reduced}$, $N_{i, reduced}$ and $N_{m, reduced}$ are substituted for N_{eq} , N_i and N_m , respectively. All anchors in a test series shall complete the simulated seismic-tension load history. Failure of an anchor to develop the required tension resistance in any cycle prior to completing the loading history given Table 9.1 shall be recorded as an unsuccessful test. The mean residual capacity of the anchors in the test series in the tension test shall be at least 160% of the reduced peak load $N_{eq, reduced}$. Successful completion of the reduced cyclic loading history and fulfillment of the residual tension capacity requirement of this Section shall be reported together with an anchor pullout capacity N_p as given by Eq. (9-2) to be reported in Table 11.2 for use in cases that include earthquake loading.

$$N_p = N_b \frac{N_{eq, reduced}}{N_{eq}} \tag{9-2}$$

The value of N_b as given in Eq. (9-2) shall be determined in accordance with ACI 318 whereby the value of k is determined in accordance with Section 7.3. If the pull-out or pull-through failure modes predominate in the reference tension tests in cracked concrete (Table 4.2, Tests 3 and 4), N_p shall be substituted for N_b in Eq. (9-2). Anchors of a given diameter that are tested at shallow and deep embedments as per Table 5.7 shall be evaluated at each embedment depth independently. Evaluation of intermediate embedment depths not tested shall be by linear interpolation.

9.6 Service-condition, simulated seismic shear tests (Table 4.2, Test 19)

9.6.1 These optional tests are intended to evaluate the performance of anchors subjected to seismic shear loads, including the effects of concrete cracking. If these seismic tests are performed, they shall only be acceptable as part of the total cracked concrete test program of Table 4.2.

9.6.2 Test each anchor diameter at embedments as specified in Table 5.7. Install the anchor in a closed crack in accordance with Section 5.4.1. If no torque is specified by the manufacturer, finger-tighten the anchor prior to testing. Test internally threaded anchors with the bolt specified by the manufacturer and report the bolt type in Table 11.2. Open the crack by $\Delta w = 0.020$ in. (0.5 mm) where Δw is additive to the initial (hairline) crack width. Subject the anchors to the sinusoidal shear loads specified in Table 9.2 and Fig. 9.2 with the shear load applied parallel to the direction of the crack, whereby V_{eq} , V_m , and V_i are as follows:

$$V_{eq} = 0.5 F_{u, test, 17} \left[\frac{f_{u, test, 19}}{f_{u, test, 17}} \right] \tag{9-3}$$

where:

- $F_{u, test, 17}$ = the mean anchor shear capacity as measured in tests (Table 4.2, Test 17);
- $f_{u, test, 19}$ = the mean steel strength of the tested anchors in the simulated seismic shear tests (Table 4.2, Test 19);

ACCEPTANCE CRITERIA FOR MECHANICAL ANCHORS IN CONCRETE ELEMENTS (AC193)

$f_{u,test,17}$	=	the mean steel strength of the tested anchors in the service condition shear tests (Table 4.2, Test 17);
V_m	=	one-fourth of the mean shear capacity in cracked concrete from test or calculated from steel capacity; and
V_i	=	$(V_{eq} + V_m) / 2$

If the service condition shear tests (Table 4.2, Test 17) have not been performed, V_{eq} shall be permitted to be evaluated as per Eq. (9-4).

$$V_{eq} = 0.5 (0.7 A_{se} \cdot f_{u,test,19}) \quad (9-4)$$

The frequency of loading shall be between 0.1 and 2 Hz. To reduce the potential for uncontrolled slip during load reversal, the alternating shear loading shall be permitted to be approximated by the application of two half-sinusoidal load cycles at the desired frequency connected by a reduced-speed, ramped load as shown in Fig. 9.3.

Record the crack width, anchor displacement and applied load in accordance with Section 5.4.3. Plot the load-displacement history in the form of hysteresis loops.

Following completion of the simulated seismic-shear cycles, open the crack to a width not less than the crack opening width as measured at the end of the cyclic shear test and load the anchor in shear to failure. Record the maximum shear load (residual shear capacity), the corresponding displacement, and plot the load-displacement response.

9.6.3 Requirements—All anchors in a test series shall complete the simulated seismic-shear load history specified in Table 9.2 and Fig. 9.2. Failure of an anchor to develop the required shear resistance in any cycle prior to completing the loading history specified in Table 9.2 and Fig. 9.2 shall be recorded as an unsuccessful test. The mean residual capacity of the anchors in the test series shall be at least 160 percent of V_{eq} as given by Eq. (9-3) or Eq. (9-4).

Successful completion of the cyclic loading history and fulfillment of the residual shear capacity requirement of this Section shall be reported together with an anchor capacity V_s , equal to the characteristic value, V_{st} , determined from the static shear test results (Table 4.2, Test 17), to be reported in Table 11.2 for use in cases that include earthquake loading.

If the anchor fails to fulfill the above requirements at V_{eq} , it shall be permitted to conduct the test with reduced cyclic loads conforming to the loading history specified in Table 9.2 and Fig. 9.2 whereby $V_{eq, reduced}$, $V_{i, reduced}$ and $V_{m, reduced}$ are substituted for V_{eq} , V_i and V_m , respectively. All anchors in a test series shall complete the simulated seismic-shear load history. Failure of an anchor to develop the required shear resistance in any cycle prior to completing the loading history given Table 9.2 shall be recorded as an unsuccessful test. The mean residual capacity of the anchors in the test series in the tension test shall be at least 160% of the reduced peak load $V_{eq, reduced}$. Successful completion of the reduced cyclic loading history and fulfillment of the residual shear capacity requirement of this Section shall be reported together with a nominal anchor shear capacity V_s to be reported in Table 11.2 for use in cases that include earthquake loading.

$$V_s = V_{st} \cdot \frac{V_{eq, reduced}}{V_{eq}} \quad (9-5)$$

For a given anchor diameter, all embedment depths greater than the tested embedment depth shall be qualified at the value of V_s determined in accordance with Eq. (9-5). Evaluation of V_s for embedment depths between the tested embedment depths shall be by linear interpolation.

9.7—Torque Tests (Table 4.1, Test 15 and Table 4.2, Test 20)

9.7.1 Purpose—These optional torque tests are performed in uncracked concrete for establishing whether or not the anchors of the same design, but of different production methods, materials, coatings, or prestressing mechanisms have the same performance. The tests also can be used to establish the appropriate installation or tightening torques so that the anchor is installed or tightened appropriately and the anchor does not function in the yield range of the material.

9.7.2 General test conditions—Fig 9.4 gives the test setup. The fixture shall contain all parts shown in Fig. 9.4. During the test use a setup that avoids the turning of the washer on the fixture. One method is the use of double-sided abrasive paper. Apply a torque with a calibrated torque wrench until it cannot take further torque, or at least to $1.3 T_{inst}$. Measure the tension force in the bolt as a function of the applied torque.

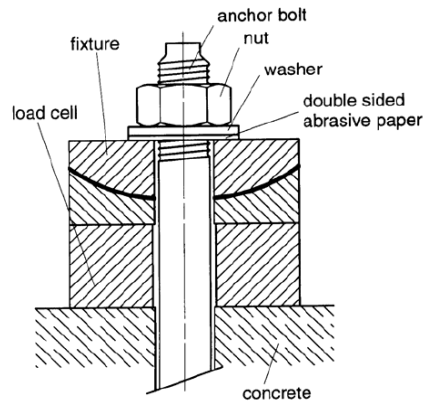

FIGURE 9.4—TORQUE TEST SETUP

9.7.3 Requirement—The 95% fractile of the tension force at a torque of $1.3T_{inst}$ shall be less than the yield force ($A_{se} f_y$) or for anchors without a defined yield strength, $1.3T_{inst}$ shall be less than ($A_{se} \times 0.8f_{ult}$) of the bolt or anchor rod for torque-controlled expansion anchors, and of the sleeve for displacement-controlled expansion anchors. For torque-controlled expansion anchors with nuts, no turning of the anchors shall occur up to a torque of $1.3T_{inst}$. After the test the connection shall be capable of being disassembled.

9.8 Service-condition tension test, installation through the soffit of concrete-filled metal deck floor and roof assemblies (Table 4.2, Test 21 or Table 4.3, Test 13)

9.8.1 Purpose—These optional tests are intended to evaluate the tension performance of anchors installed through metal decking into concrete fill.

9.8.2 Tests—Install anchors through the metal decking and into the concrete fill in accordance with manufacturer's instructions. (See Fig. A3.2). To qualify anchor installation into the lower flute of metal decking, test anchors shall be installed as depicted in Figure A3.2, with the maximum desired offset from the lower flute centerline. To qualify anchor installation into the upper flute of metal decking, the test anchors shall be installed in the upper flute. Perform tension tests in accordance with ASTM E 488, with continuous measurement of load and displacement.

9.8.2 Requirements—The coefficient of variation, v , of the peak tension loads in the test series shall not exceed 15 percent. The sample size shall be permitted to be increased if the coefficient of variation obtained from the original sample size does not meet this requirement. If this requirement is not met, the anchor shall be considered unqualified for this application.

9.9—Service-condition shear test, installation through the soffit of concrete-filled metal deck floor and roof assemblies (Table 4.2, Test 22 or Table 4.3, Test 14)

9.9.1 Purpose—These optional tests are intended to evaluate the shear performance of anchors installed through metal decking into concrete fill.

9.9.2 Tests—Install anchors through the metal decking and into the concrete fill in accordance with manufacturer's instructions. To qualify anchor installation into the lower flute of metal decking, test anchors shall be installed as depicted in Figure A3.2, with the maximum desired offset from the lower flute centerline. To qualify anchor installation into the upper flute of metal decking, the test anchors shall be installed in the upper flute. Perform shear tests with the loads applied perpendicular to the flute and toward the nearest flute edge in accordance with ASTM E 488, with continuous measurement of load and displacement.

9.9.3 Requirements—The coefficient of variation, v , of the peak shear loads in the test services shall not exceed 15 percent. The sample size shall be permitted to be increased if the coefficient of variation obtained from the original sample size does not meet this requirement. If this requirement is not met, the anchor shall be considered unqualified for this application.

TABLE 10.1—ESTABLISHMENT OF ANCHOR CATEGORIES

SMALLEST RATIO OF CHARACTERISTIC CAPACITIES	ANCHOR CATEGORY
$0.80 \leq N_{b,r} / N_{b,o}$	1
$0.70 \leq N_{b,r} / N_{b,o} < 0.80$	2
$0.60 \leq N_{b,r} / N_{b,o} < 0.70$	3
$0.50 \leq N_{b,r} / N_{b,o} < 0.60$	Refer to Section 10.1.1
If $N_{b,r} / N_{b,o} < 0.50$	Anchor is unqualified

10.1.1 For anchors with the smallest ratio of characteristic capacities ($N_{b,r}/N_{b,o}$) less than 0.60 and greater than or equal to 0.50, the anchor shall be assigned anchor category 3 and N_p taken from Section 7.3.3 shall be multiplied by the ratio ($N_{b,r}/N_{b,o}$)/0.60.

Exception for anchors qualified exclusively for redundant applications: For each combination of anchor diameter and embedment depth, compute the ratio of the characteristic capacity $N_{b,r}$ in each reliability test to the characteristic tension capacity $N_{b,o}$ in the corresponding reference test as shown in Table 10.2.

Determine the characteristic capacity in accordance with Appendix A2. The K value used in calculating the characteristic capacity in each reliability test and in the corresponding reference test shall be the K value associated with the reliability test or reference test that has the fewest number of respective replicates.

TABLE 10.2 — TESTS USED TO CALCULATE RELIABILITY/REFERENCE RATIOS FOR ANCHORS QUALIFIED EXCLUSIVELY FOR REDUNDANT APPLICATIONS

Reliability Test in (Table 4.3)	Reference Test in (Table 4.3)
4	2
5	2
6	2
7	1
8	1 or 3 (depending on test method)

10.3 The characteristic tension capacity evaluated from the results of Test No. 21, Table 4.2 in accordance with Appendices A1 and A2 shall be taken as the pullout capacity N_p , in uncracked concrete. The pullout capacity in cracked concrete shall be evaluated as $\Psi_{3,pullout} N_p$, where $\Psi_{3,pullout}$ is evaluated in accordance with Eq. (10-1). The anchor category shall be taken as established in accordance with Section 10.1 and 10.2.

$$\Psi_{3,pullout} = N_{p,cr} / N_{p,uncr} \tag{10-1}$$

where:

- $\Psi_{3,pullout}$ = the ratio of measured pullout capacities in normal-weight uncracked and cracked concrete.
- $N_{p,cr}$ = the measured pullout capacity in normal-weight cracked concrete, lb (N).
- $N_{p,uncr}$ = the measured pullout capacity in uncracked normal-weight concrete, lb (N).

Exception: For anchors qualified exclusively for redundant applications, the characteristic tension capacity evaluated from the results of Test No. 13, Table 4.3 in accordance with Appendices A1 and A2 shall be multiplied by $\Psi_{4,pullout}$ where $\Psi_{4,pullout}$ is evaluated in accordance with Eq. (10-2). The anchor category shall be taken as established in accordance with Section 10.1 and 10.2.

$$\Psi_{4,pullout} = N_{ra,cr} / N_{ra,uncr} \tag{10-2}$$

where:

- $\Psi_{4,pullout}$ = the ratio of measured pullout capacities in normal-weight uncracked and cracked concrete.
- $N_{ra,cr}$ = the characteristic tension capacity evaluated from the results of Test No. 2, Table 4.3 in accordance with Appendices A1 and A2, lb (N).
- $N_{ra,uncr}$ = the characteristic tension capacity evaluated from the results of Test No. 1, Table 4.3 in accordance with Appendices A1 and A2, lb (N).

ACCEPTANCE CRITERIA FOR MECHANICAL ANCHORS IN CONCRETE ELEMENTS (AC193)

10.4 The characteristic shear capacity evaluated from the results of Test No. 22, Table 4.2 in accordance with Appendices A1 and A2 shall be taken as the steel strength of the anchor in shear, V_s , in uncracked and cracked concrete.

Exception: For anchors qualified exclusively for redundant applications, the characteristic shear capacity evaluated from the results of Test No. 14, Table 4.3 in accordance with Appendices A1 and A2 shall be recorded.

10.5 Anchors installed in the soffit of concrete-filled metal deck assemblies shall be placed in the lower flute and shall have an axial spacing along the flute equal to the greater of $3h_{ef}$ or $1.5 \times$ flute width.

10.6 For the design of anchor in the lower flute of concrete on metal deck assemblies in accordance with ACI 318 Appendix D, the following supplemental requirements shall apply.

Exception: For anchors qualified exclusively for redundant applications, the value $F_{ra\ deck}$ shall be the lesser of the characteristic tension capacity evaluated per 10.3 or the characteristic shear capacity evaluated per 10.4 and 10.6.1 and 10.6.2 do not apply. Report $F_{ra\ deck}$ in Table 11.3.

10.6.1 *Tension*—For the case of anchors installed in the lower flute of concrete on metal deck assemblies in accordance with 10.3 and loaded in tension, the evaluation of the concrete breakout capacity in accordance with ACI 318 Appendix D5.2 is not required.

10.6.2 *Shear*—For the case of anchors installed in the lower flute of concrete filled metal deck assemblies in accordance with 10.4 and loaded in shear, evaluation of the concrete breakout capacity in accordance with ACI 318 Appendix D6.2 and the pryout capacity in accordance with ACI 318 Appendix D6.3 are not required.

11.2 Format of the data sheet—Report the data required by ACI 355.2 in the format shown in Table 11.1, 11.2 or 11.3. Add other observations as appropriate and include them in the evaluation report. For anchors qualified exclusively for redundant applications, report the lower of N_{ra} and V_{ra} as F_{ra} in Table 11.3.

11.4.5 Maximum output power rating for tools used for anchor installation.

11.4.6 Proprietary torque-limiting installation tools, if required.

11.4.7 Proprietary power installation tools, if required.

ACCEPTANCE CRITERIA FOR MECHANICAL ANCHORS IN CONCRETE ELEMENTS (AC193)

TABLE 11.1—SAMPLE FORMAT FOR REPORTING ANCHOR DATA FOR ANCHORS QUALIFIED FOR USE IN UNCRACKED CONCRETE ONLY

ANCHOR SYSTEM QUALIFIED FOR USE IN UNCRACKED CONCRETE IN ACCORDANCE WITH TEST PROGRAM OF TABLE 4.1								
Characteristic	Symbol	Units	Section Reference	Nominal Anchor Diameters				
				Smaller Diameters (if any)	3/8 inch (M10)	1/2 inch (M12)	5/8 inch (M16)	Larger Diameters (if any)
Installation Information								
Outside diameter	d_o	in. (mm)	2.2					
Effective embedment depth	h_{ef}	in. (mm)	2.2					
Installation torque	T_{inst}	ft-lb (N × m)	2.2					
Minimum edge	c_{min}	in. (mm)	2.2					
Minimum spacing	s_{min}	in. (mm)	2.2					
Minimum concrete thickness	h_{min}	in. (mm)	2.2					
Critical edge distance ¹	C_{cr}	in. (mm)	2.2, 9.2					
Anchor Data								
Category number	1, 2, or 3	—	10.1					
Yield strength of anchor steel	f_y	lb/in ² (MPa)	2.2					
Ultimate strength of anchor steel	f_{ut}	lb/in ² (MPa)	2.2					
Tensile stress area	A_{se}	in ²	2.2					
Shear stress area	A_{se}	in ²	2.2					
Shear strength of sleeved anchors	V_s	lb (N)	9.4.1					
Effectiveness factor for concrete breakout	k_{uncr}	—	7.3.1 7.3.2 7.3.3					
Modification factor for absence of cracks	$\psi_{c,n}$	—	2.2	1.0	1.0	1.0	1.0	1.0
Pullout or pull-through resistance from tests	N_p	lb (N)	7.3.3					
Axial stiffness in service load range	β	lb/in. (kN/mm)	5.5.2					
Coefficient of variation for axial stiffness in service load range	n	%	5.5.2					

¹If the critical edge distance is $c_{cr} \geq 1.5 h_{ef}$ then for applications with $c < c_{cr}$ in at least one direction, the concrete breakout strength of anchors in tension calculated according to ACI 318 D5.2, shall be multiplied by a factor ψ_{edge} given by Eq. (9-1).

ACCEPTANCE CRITERIA FOR MECHANICAL ANCHORS IN CONCRETE ELEMENTS (AC193)

TABLE 11.2—SAMPLE FORMAT FOR REPORTING ANCHOR DATA
FOR ANCHORS QUALIFIED FOR USE IN BOTH CRACKED AND UNCRACKED CONCRETE

ANCHOR SYSTEM QUALIFIED FOR USE IN CRACKED AND UNCRACKED CONCRETE IN ACCORDANCE WITH TEST PROGRAM OF TABLE 4.2								
Characteristic	Symbol	Units	Section Reference	Nominal Anchor Diameters				
				Smaller Diameters (if any)	$\frac{3}{8}$ inch (M10)	$\frac{1}{2}$ inch (M12)	$\frac{5}{8}$ inch (M16)	Larger Diameters (if any)
Installation Information								
Outside diameter	d_o	in. (mm)	2.2					
Effective embedment depth	h_{ef}	in. (mm)	2.2					
Installation torque	T_{inst}	ft-lb (N × m)	2.2					
Minimum edge	c_{min}	in. (mm)	2.2					
Minimum spacing	s_{min}	in. (mm)	2.2					
Minimum concrete thickness	h_{min}	in. (mm)	2.2					
Critical edge distance ¹	c_{cr}	in. (mm)	2.2					
Anchor Data								
Category number	1, 2, or 3	—	10.1					
Yield strength of anchor steel	f_y	lb/in ² (MPa)	2.2					
Ultimate strength of anchor steel	f_{ut}	lb/in ² (MPa)	2.2					
Tensile stress area	A_{se}	in ²	2.2					
Shear stress area	A_{se}	in ²	2.2					
Shear strength of anchors	V_s	lb (N)	9.4 9.4.1					
Effectiveness factor—uncracked concrete	k_{uncr}	—	7.3.1 7.3.2 7.3.3					
Effectiveness factor—cracked concrete	K_{cr}	—	7.3.1 7.3.2 7.3.3					
$\Psi_{c,n}$ for ACI 318 design in cracked concrete	$\Psi_{c,n}$		2.2	1.0	1.0	1.0	1.0	1.0
$\Psi_{c,n} = k_{uncr}/K_{cr}$ for ACI 318 design in uncracked concrete	$\Psi_{c,n}$	—	2.2					
Pullout or pull-through resistance from tests	N_p	lb (N)	7.3.3					
Tension resistance from single anchor for seismic loads	N_{eq}	lb (N)	9.5					
Shear resistance of single anchor for seismic loads	V_{eq}	lb (N)	9.6					
Axial stiffness in service load range	B	lb/in. (kN/mm)	5.5.2					
Coefficient of variation for axial stiffness in service load range	N	%	5.5.2					

¹If the critical edge distance is $c_{cr} \geq 1.5 h_{ef}$ then for applications with $c < c_{cr}$ in at least one direction, the concrete breakout strength of anchors in tension calculated according to ACI 318 D5.2, shall be multiplied by a factor ψ_{edge} given by Eq. (9-1).

TABLE 11.3 — SAMPLE FORMAT FOR REPORTING ANCHOR DATA FOR ANCHORS QUALIFIED EXCLUSIVELY FOR REDUNDANT APPLICATIONS

ANCHOR SYSTEM QUALIFIED EXCLUSIVELY FOR USE WITH REDUNDANT APPLICATIONS IN CRACKED CONCRETE IN ACCORDANCE WITH TEST PROGRAM OF TABLE 4.3								
Characteristic	Symbol	Units	Section Reference	Nominal Anchor Diameters				
				3/16 inch (M5)	1/4 inch (M6)	5/16 inch (M10)	3/8 inch (M12)	larger diameter (if any)
Installation Information								
Outside diameter	d_o	in. (mm)	2.2					
Nominal embedment depth	h_{nom}	in. (mm)	2.2					
Effective embedment depth	h_{ef}	in. (mm)	2.2					
Installation Torque	T_{inst}	ft - lb. (N-m)	2.2					
Minimum edge	c_{min}	in. (mm)	2.2					
Minimum spacing	s_{min}	in. (mm)	2.2					
Minimum spacing, concrete over metal deck	$s_{min, deck}$	in. (mm)	2.2					
Minimum concrete thickness	h_{min}	in. (mm)	2.2					
Anchor Data								
Category number	1, 2 or 3	-	10.1					
Strength reduction factor	ϕ_{ra}	-	A4.2.7					
Resistance, normal weight concrete	F_{ra}	lbs. (kN)	A4.2.6					
Resistance, sand lightweight concrete over metal deck	$F_{ra, deck}$	lbs. (kN)	10.6					

A1.2—Concrete breakout or splitting failure

Normalize capacities in proportion to $\sqrt{f'_c}$ as prescribed by Eq. (A1-1)

Exception: For anchors qualified exclusively for redundant applications, reliability tests need not be normalized.

A1.3—Pullout and pull-through failure

The influence of the concrete strength on the pullout or pull-through failure load shall be established by tests. Report the capacity at the lowest concrete compressive strength of the range and the capacity variation as a function of concrete strength (for example, linear, or as a specific mathematical function of the concrete compressive strength.)

Exception: For anchors qualified exclusively for redundant applications, the influence of the concrete strength on the pullout or pull-through failure load for reference and service-condition tests shall be normalized in proportion to $\sqrt{f'_c}$ as prescribed by Eq. (A1-1). For anchors qualified exclusively for redundant applications, reliability tests need not be normalized.

ACCEPTANCE CRITERIA FOR MECHANICAL ANCHORS IN CONCRETE ELEMENTS (AC193)

A3.2—Tests in cracked concrete

Test members shall be permitted to contain reinforcement to allow handling, the distribution of loads transmitted by test equipment, or both. Place the reinforcement so that the capacity of the tested anchor is not affected.

The crack opening width shall be approximately uniform throughout the member thickness. The member thickness shall not be less than h_{min} but at least 4 in. (100 mm). To control the location of cracks and to help ensure that the anchors are installed to the full depth in the crack, crack inducers shall be permitted to be installed in the member, provided they are not situated so as to influence the test results. An example of the test member is given in Fig. A3.1. For test members that use internal reinforcement to control the crack width, the reinforcement shall be placed so that there is no influence on the performance of the anchors. The cross-sectional reinforcement ratio of the concrete members used for cracked concrete tests should be about 1 percent with a spacing of the top and bottom crack control reinforcement bars ≤ 10 inches (254 mm). The reinforcement shall be permitted to be in the cone of concrete. The centerline to centerline distance between the reinforcement and the anchor shall be greater than $0.4 h_{ef}$. An example of a test member is given in Fig. A3.1.

A3.4—Test members for testing anchors installed in the soffit of concrete fill on metal deck floor and roof assemblies

Cast test members having the minimum concrete fill thickness, maximum decking depth, minimum flute width and minimum metal thickness that the assessment should cover. The concrete fill shall contain no reinforcing. Lightweight concrete fill shall be permitted to be used. Test members may be inverted and placed flat on the floor of the test facility to facilitate tension testing of anchors installed through the decking and into the fill concrete. Test set-up details are shown in Fig. A3.2.

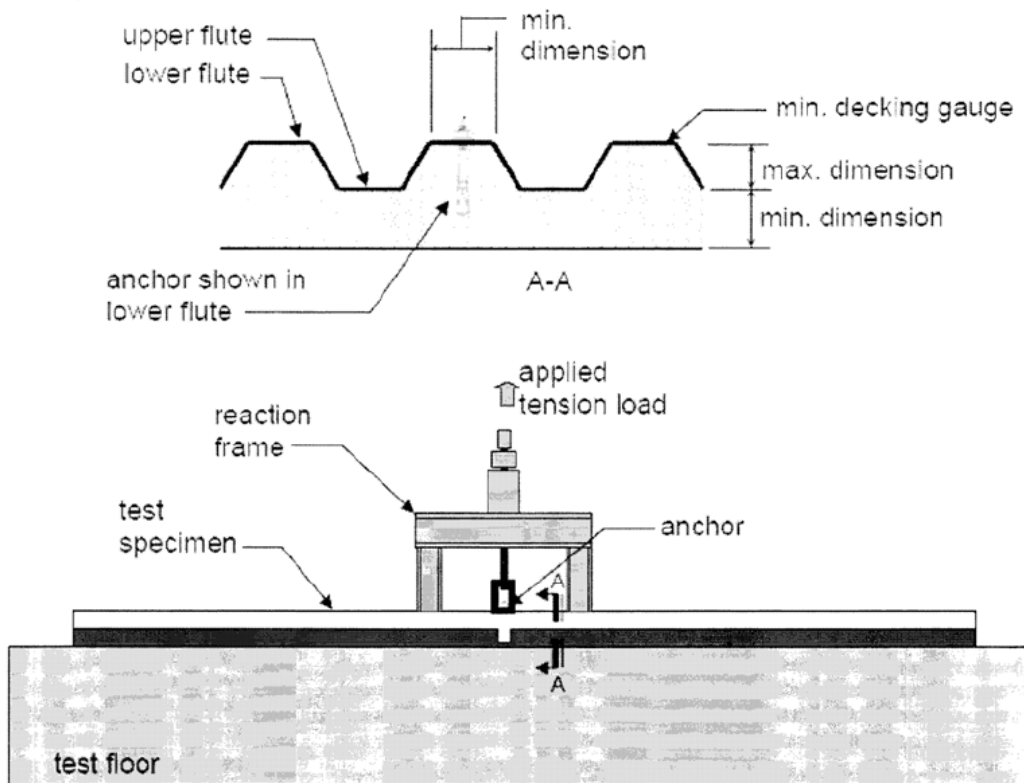

FIGURE A3.2

**APPENDIX A4 - REQUIREMENTS FOR THE DESIGN OF ANCHORS
QUALIFIED EXCLUSIVELY FOR REDUNDANT APPLICATIONS**

A4.1 General:

A4.1.1 For an anchoring system designed with redundancy, the load maintained by an anchor that experiences failure or excessive deflection can be transmitted to neighboring anchors without significant consequences to the fixture or remaining resistance of the anchoring system. In addition to the requirements for anchors, the fixture being attached shall be able to resist the forces acting on it assuming one of the fixing points is not carrying load. It is assumed that by adhering to the limits placing on n_1 , n_2 and n_3 below, redundancy will be satisfied.

A4.1.2 Anchors qualified for redundant applications may be designed for use in normal weight and sand-lightweight cracked and uncracked concrete. Concrete compressive strength of 2,500 psi shall be used for design. No increase in anchor capacity is permitted for concrete compressive strengths greater than 2,500 psi. The anchor installation is limited to concrete with a compressive strength of 8,500 psi or less.

A4.1.3 Redundant applications shall be limited to structures assigned to Seismic Design Categories A or B only.

A4.1.4 The ability of the fixed element to transfer loads to adjacent anchors to adjacent anchors shall be justified to the satisfaction of the code official.

A4.1.5 Redundant applications shall be limited to support of nonstructural elements.

A4.2 Strength Design:

A4.2.1 For strength design, a redundant system is achieved by specifying and limiting the following variables (See Fig. A4.1):

- n_1 = the total number of anchorage points supporting the linear element
- n_2 = number of anchors per anchorage point
- n_3 = factored load at each anchorage point, lbs., using load combinations from IBC Section 1605.2.1 or ACI 318 Section 9.2

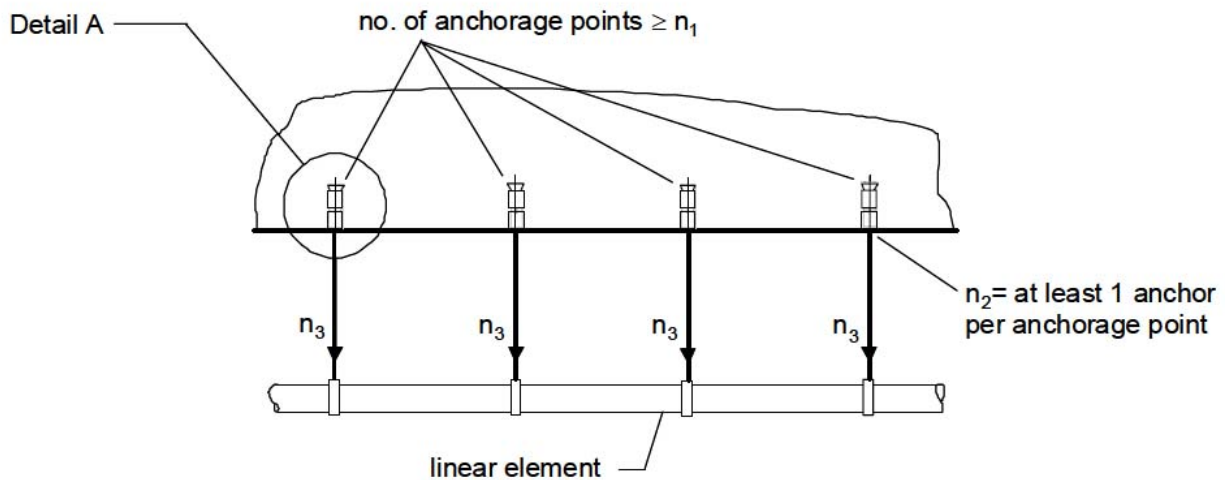

FIGURE A4.1 — DEFINITION OF n_1 , n_2 , AND n_3

A4.2.2 The following combinations have been determined to be adequate in satisfying redundancy for strength design of typical fixtures (See Fig. A4.2):

$$n_1 \geq 4, n_2 \geq 1 \text{ and } n_3 \leq 675 \text{ lbs. (3005 N)} \quad (\text{or})$$

$$n_1 \geq 3, n_2 \geq 1 \text{ and } n_3 \leq 450 \text{ lbs. (2005 N)}$$

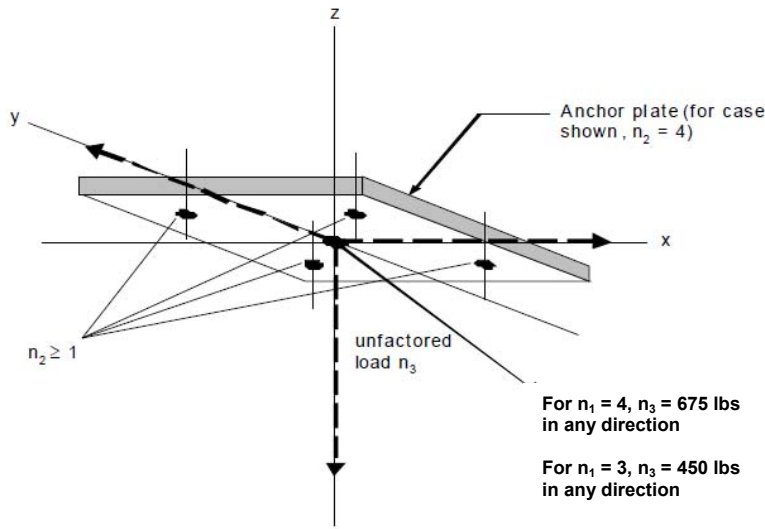

FIGURE A4.2 — DETAILS A FOR STRENGTH DESIGN

A4.2.3 For the redundant applications of anchors loaded in tension the following equation shall be satisfied:

$$\phi_{ra} F_{ra} \geq N_{ua} \tag{Eq. A4-1}$$

A4.2.4 For the redundant applications of anchors loaded in shear the following equation shall be satisfied:

$$\phi_{ra} F_{ra} \geq V_{ua} \tag{Eq. A4-2}$$

A4.2.5 For combined tension and shear loading the following equation shall be satisfied:

$$\phi_{ra} F_{ra} \geq \sqrt{(N_{ua})^2 + (V_{ua})^2} \tag{Eq. A4-3}$$

A4.2.6 In Eq. A4-1, A4-2 and A4-3, F_{ra} is the lowest characteristic resistance in lbs. (N) determined from testing and evaluation of data in accordance with Table 4.3, is independent of load direction, and is applicable for cracked and uncracked concrete.

A4.2.7 In Eq. A4-1, A4-2 and A4-3, ϕ_{ra} is determined from the table below based on the anchor category evaluated in accordance with AC193:

Anchor Category	ϕ_{ra}
1	0.65
2	0.55
3	0.45

A4.2.8 For the redundant applications of fasteners installed in structural sand-lightweight concrete, the resistance shall be replaced with $0.6 \phi_{ra} F_{ra}$ in Eq. A4-1, A4-2 and A4-3.

A4.2.9 For the redundant applications of fasteners installed in the lower flute of structural sand-lightweight concrete on metal deck assemblies, F_{ra} shall be replaced with $F_{ra,deck}$ in Eq. A4-1, A4-2 and A4-3.

A4.3 Allowable Stress Design

A4.3.1 For allowable stress design, a redundant system is achieved by specifying and limiting the following variables:

ACCEPTANCE CRITERIA FOR MECHANICAL ANCHORS IN CONCRETE ELEMENTS (AC193)

n_1 = the total number of anchorage points supporting the linear element
 n_2 = number of anchors per anchorage point
 n_3 = load at each anchorage point, lbs. (N)

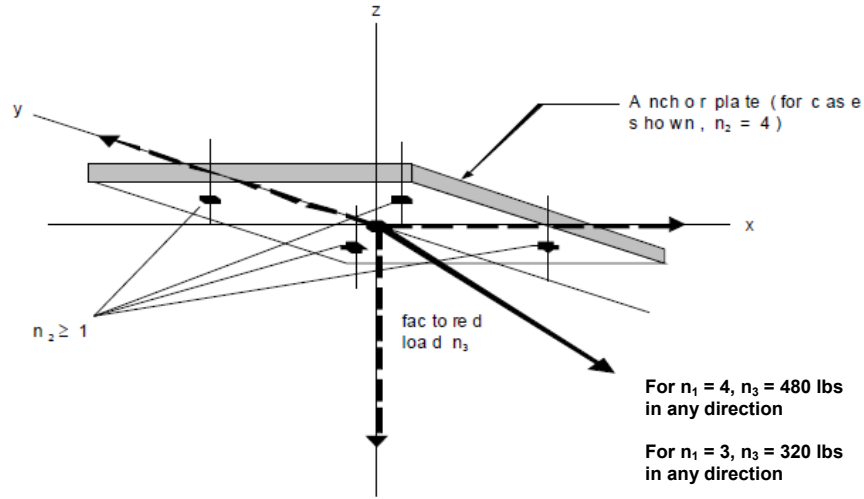

FIGURE A4.3 — DETAIL A FOR ALLOWABLE STRESS DESIGN

A4.3.2 The following combinations have been determined to be adequate in satisfying redundancy for allowable stress design of typical fixtures (see Fig. A4.3):

$$n_1 \geq 4, n_2 \geq 1 \text{ and } n_3 \leq 480 \text{ lbs. (2135 N)} \quad (\text{or})$$

$$n_1 \geq 3, n_2 \geq 1 \text{ and } n_3 \leq 320 \text{ lbs. (1425 N)}$$

A4.3.3 Design values for use with allowable stress design shall be established in accordance with AC193 Section 6.4.3 taking $R_d = \Phi_{ra} F_{ra}$.

A4.4 Required Edge Distances, Spacings, and Thicknesses

A4.4.1 The minimum edge distances, spacings and member thicknesses shall be observed:

Edge distance	$C_{min} = C_{ac}$	= $3h_{ef} \geq 4 \text{ in. (102 mm)}$
Spacing	S_{min}	= $4h_{ef} \geq 8 \text{ in. (203 mm)}$
Spacing, metal deck	$S_{min,deck}$	= $3h_{ef} \geq 1.5 \times \text{flute width}$
Member thickness	h_{min}	= $2h_{ef} \geq 3 \text{ in. (76 mm)}$