



ICC Evaluation Service, Inc.  
Los Angeles Business/Regional Office  
5360 Workman Mill Road  
Whittier, CA 90601  
tel: 562.699.0543  
fax: 562.695.4694  
www.icc-es.org

December 1, 2009

**TO: PARTIES INTERESTED IN PLASTIC GLAZED SKYLIGHTS**

**SUBJECT: Proposed Revisions to the Acceptance Criteria for Plastic Glazed Skylights, Subject AC16-1209-R2 (RK/DP)**

Dear Madam or Sir:

The revisions proposed to the subject acceptance criteria, as presented in the enclosed criteria draft, are being posted on the ICC-ES web site to allow for public comment. The revisions are based on the revisions proposed in the enclosed e-mail dated October 16, 2009, from Dan State of Solatube, which included a copy of a previous industry letter dated October 20, 2008. The proposed revisions include:

1. Deletion of the additional air infiltration tests from Section A3.3.
2. Deletion of Section A6.2, which currently requires the evaluation reports to indicate compliance with the air infiltration conditions of acceptance.

The proposed revisions are similar to revisions proposed at the October 6, 2009, ICC-ES Evaluation Committee hearing under subject AC16-1009-R1. The previously proposed revisions were held for further study by the committee in response to concerns raised by both the industry and ICC-ES staff over the content of published evaluation reports in regard to air infiltration test results being applicable to all of the skylight sizes recognized in the evaluation reports.

The difference between the currently proposed revisions and those considered at the October 2009 hearing is the proposed deletion of Section A6.2.

The ICC-ES staff concurs with the new proposed deletion of Section A6.2 in conjunction with deletion of Section A3.3, since published evaluation reports would not be required to contain air infiltration results of the tested skylight, and thus would not imply that all skylight sizes noted in the evaluation report have been evaluated for, and comply with, the condition of acceptance for air infiltration testing.

You are cordially invited to submit written comments, within 30 days of the date of this letter. Please use the comment form on the web site attaching any letters to the form. An explanation of the alternate criteria process can be found on our web site at [http://www.icc-es.org/Criteria\\_Development/alternative\\_criteria\\_process.shtml](http://www.icc-es.org/Criteria_Development/alternative_criteria_process.shtml).

All comments received in the 30-day comment period will be considered. During this same 30-day period, however, the draft criteria will be balloted to the Evaluation Committee. If the public comments raise major issues, generate controversy, or require the criteria to be substantially rewritten, then ICC-ES staff may decide to reballot the criteria; or place a revised draft on the web site for further public comment; or put the criteria on the agenda for a future Evaluation Committee meeting.

Correspondence received and a memo outlining staff's resolution of the comments in the correspondence will be posted on the web site shortly after the close of the comment period.

Your cooperation is requested in forwarding to the Los Angeles business/regional office all material directed to the Evaluation Committee. Parties interested in the deliberations of the committee should refrain from communicating, whether in writing or verbally, with committee members. The committee reserves the right to refuse communications that do not comply with this request.

Newly approved acceptance criteria may involve test methods or test protocols that are not currently included in the scope of testing services offered by accredited testing laboratories. As noted in the ICC-ES Rules of Procedure for Evaluation Reports, the scope of the laboratory's accreditation must include the type of testing that is to be reported to ICC-ES. We encourage accredited laboratories to expand their scopes of accreditation to include testing under newly approved acceptance criteria. Please note that testing laboratories must be accredited by the International Accreditation Service (IAS) or by another accreditation body that is a signatory to the International Laboratory Accreditation Cooperation Mutual Recognition Arrangement. For further information, please contact IAS at (562) 699-0541, extension 3309, or send an e-mail to [pmccullen@iasonline.org](mailto:pmccullen@iasonline.org).

Please submit all comments using the form on the web site. Attach any letters to the comment form. If you have any questions (not comments), please contact the undersigned at (800) 423-6587, extension 3275, or David Pereg, Staff Engineer, at extension 3275. You may also reach us by e-mail at [es@icc-es.org](mailto:es@icc-es.org).

Yours very truly,

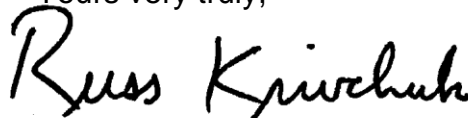

Russ Krivchuk  
Senior Staff Engineer

RK/raf

Enclosures

cc: Evaluation Committee

**Rosalind Fazel**

---

**From:** State, Dan [dstate@solatube.com]  
**Sent:** Friday, October 16, 2009 5:36 PM  
**To:** Russ Krivchuk  
**Cc:** Rosalind Fazel; Roger LeBrun; Dave De Block  
**Subject:** Subject AC16-0209-R1  
**Attachments:** VELUX&ODLletter102008

**Importance:** High

Dear Mr. Krivchuk,

We would like to thank you one more time for working with us on this issue and to take the time to listen to our concerns during and after the Hearings in Los Angeles on October 06, 2009.

At this moment is our understanding that based on your letter dated September 01, 2009 and additional supporting documents, including the Proposed September 2009 AC16, the staff proposed deletion of Section A3.3. We are supporting this deletion as indicated during the hearing.

Please find attached the initial letter from VELUX and ODL as supporting document for staff proposed change of Section A3.3.

During the hearing on October 06, 2009, we expressed our concern about another proposed change by ICC-ES staff: **Section A6.2.**

The Acceptance Criteria AC16 Section A3.1.1, indicates THAT ONE SKYLIGHT OF EACH SKYLIGHT MODEL shall be tested for all three sequential tests: air infiltration, water penetration and uniform load, **in order to qualify entire family of the same construction (model).**

As mentioned during the hearing we consider that the proposed change for Section # A6.2 will create confusion/misunderstandings for our end customers (architects/engineers).

The goal of the Acceptance Criteria is to define what tests are required to comply with existing codes.

The scope of the evaluation report is to review the test data and conclude on compliance with the code for entire family of products, not only for one size.

By indicating what size was tested for Air Infiltration, will trigger questions concerning what size was tested for Water Penetration and/or Uniform Load? Are the other sizes in the family passing the Air Infiltration test? Etc.

Furthermore, in order to avoid this kind of situation and to comply with existing codes, we would like to propose deletion of Section A6.2 in its entirety, and renumber the rest of Section A6 as needed.

Please advise if you need any additional info/comments.

Thanks

Dan State

Code Compliance Manager  
Solatube International, Inc.  
T: 760-477-9437  
M: 760-455-9966  
F: 760-599-9517

**To:** ICC Evaluation Service, Inc.  
Attn: Mr. Russ Krivchuk, P.E.  
5360 Workman Mill Road  
Whittier, CA 90601

October 20, 2008

**From:**

VELUX America Inc.  
P.O. Box 5001  
Greenwood, SC  
29648-5001

ODL Tubular Skylights  
133 Mata Way  
San Marcos, CA  
92069

**Subject: AC16 and AC17 – Requested Change**

Dear Mr. Krivchuk:

During a phone conversation we had a few weeks ago I expressed concern about a provision common to both of the above Acceptance Criteria, and was inquiring about the most efficient way to have the provisions revisited and perhaps changed or removed from the criteria documents. Based on your suggestion, we have decided to formally request that ICC-ES revise AC16 and AC17, as soon as reasonably practical, as indicated in this letter.

**Background**

On June 5, 2007 the ICC-ES Evaluation Committee approved extensive rewrites of major portions of Part A for both of these criteria. In separate staff memos for each criteria, dated May 1, 2007, rationale for those rewrites contain the following statement:

“The enclosed proposed criteria includes provisions under Section A3.3 for additional air infiltration tests when the size of the specimen tested under Section 3.1 is not the most critical skylight size, to evaluate a series of skylight sizes for air infiltration. Section A3.3 is based on an assumption that the skylights perimeter length relates to air infiltration performance.”

It is this new Section A3.3 that we are addressing in this letter.

**Proposed Changes**

Delete Section A3.3 in its entirety, and renumber the rest of Section A3 as needed. Applies to both AC16 and AC17.

**Reasoning**

- A. In Section A1.1 of both criteria documents, several ICC code references are listed. None of the references directly refer to air infiltration performance as a “basis for recognition” for product evaluation.
- B. The referenced IBC Section **2405** and IRC Section **R308.6** both prescribe testing and labeling conforming to *AAMA/WDMA/CSA 101/I.S.2/A440* in order to determine a product’s “performance grade rating”. Air leakage performance limits in that standard/specification are an essential component of the “performance grade rating” a product will receive. For skylights, the air leakage limit specified corresponds to the IECC and the IRC Chapter 11 limits. The standard/specification also states that performance grade ratings achieved by the prescribed “gateway size” or “maximum size tested” also apply to smaller, identically constructed units.
- C. Air leakage is mainly associated with thermal performance, although it also can influence indoor air quality\*. Another key measure of thermal performance for a skylight is U-Factor. Both air leakage and U-Factor are expressed in “0.XX/square foot” units. The National

Fenestration Rating Council assigns only one certified U-Factor value to cover all similarly-constructed sizes, and use of this value has been accepted as adequate by the building industry regardless of actual product size. It follows that air leakage should be similarly treated. (\*In most areas, some air exchange with the exterior is beneficial and desirable.)

- D. Even though they are not part of the "basis for recognition" code sections, it is nevertheless instructive to look at the IECC and IRC Chapter 11 sections related to air leakage determination. 2006 IECC Sections 402.4.2 and 502.4.1, and 2006 IRC Section N1102.4.2, all require non-site-built fenestration to be tested for air leakage in accordance with either the above standard/specification or to NFRC 400. Testing the "gateway" size (or "maximum size tested" if a gateway size is not available) is adequate per the AAMA/... standard/specification. Testing the NFRC "standard size or larger" is called for in NFRC 400. There is explicit test size reference in both, and it is inaccurate to conclude that "the code" requires a "worst case" size be tested to be compliant.
- E. Staff's rationale statement also assumes that air leakage is mostly a function of perimeter length. While this may be true for some designs, it is definitely not true for designs that use a condensation drainage system employing weep holes that do not change with size. These holes will be the major source of air leakage in such designs. Weep holes are very common elements for skylights due to the higher likelihood of condensation in overhead fenestration.
- F. Actual air leakage through fenestration openings is driven more by variations in the quality of installation and variable ambient conditions than by product characteristics. To impose additional testing costs that yield little or no benefit when there are much larger influencers is clearly unwarranted.

We are always available to address any questions, or any clarifications you may require, related to the above. We look forward to your response.

Best regards,

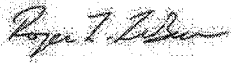

Roger LeBrun  
Product Certification Engineer  
VELUX



David A. De Block  
Director of Product Code Compliance  
ODL

## PROPOSED REVISIONS TO THE ACCEPTANCE CRITERIA FOR PLASTIC GLAZED SKYLIGHTS

### AC16

Proposed December 2009

Previously approved February 2008, June 2007, June 2006, October 2005,  
June 2004, October 2003, July 2002, April 1997, January 1997, January 1989

## PREFACE

Evaluation reports issued by ICC Evaluation Service, Inc. (ICC-ES), are based upon performance features of the International family of codes and other widely adopted code families, including the Uniform Codes, the BOCA National Codes, and the SBCCI Standard Codes. Section 104.11 of the *International Building Code*® reads as follows:

The provisions of this code are not intended to prevent the installation of any materials or to prohibit any design or method of construction not specifically prescribed by this code, provided that any such alternative has been approved. An alternative material, design or method of construction shall be approved where the building official finds that the proposed design is satisfactory and complies with the intent of the provisions of this code, and that the material, method or work offered is, for the purpose intended, at least the equivalent of that prescribed in this code in quality, strength, effectiveness, fire resistance, durability and safety.

Similar provisions are contained in the Uniform Codes, the National Codes, and the Standard Codes.

ICC-ES may consider alternate criteria, provided the report applicant submits valid data demonstrating that the alternate criteria are at least equivalent to the criteria proposed in this document, and otherwise meet the applicable performance requirements of the codes. Notwithstanding that a product, material, or type or method of construction meets the requirements of the criteria proposed in this document, or that it can be demonstrated that valid alternate criteria are equivalent to the criteria in this document and otherwise meet the applicable performance requirements of the codes, ICC-ES retains the right to refuse to issue or renew an evaluation report, if the product, material, or type or method of construction is such that either unusual care with its installation or use must be exercised for satisfactory performance, or malfunctioning is apt to cause unreasonable property damage or personal injury or sickness relative to the benefits to be achieved by the use of the product, material, or type or method of construction.

*Acceptance criteria are developed for use solely by ICC-ES for purposes of issuing ICC-ES evaluation reports.*

# PROPOSED REVISIONS TO THE ACCEPTANCE CRITERIA FOR PLASTIC GLAZED SKYLIGHTS

## PART A

### INTERNATIONAL BUILDING CODE AND INTERNATIONAL RESIDENTIAL CODE

#### A1.0 INTRODUCTION

**A1.1 Purpose:** The purpose of Part A of this acceptance criteria is to establish requirements for plastic glazed skylights to be recognized in an ICC Evaluation Service, Inc. (ICC-ES), evaluation report under the 2006 *International Building Code*® (IBC) and the 2006 *International Residential Code*® (IRC). Bases of recognition are IBC Sections 104.11, 2405, and 2610, and IRC Sections R104.11 and R308.6.

The reason for development of this criteria is to establish guidelines for the evaluation of plastic glazed skylights and to provide additional information to clarify the requirements of the IBC, IRC and documents referenced by those codes.

**A1.2 Scope:** This criteria is applicable to the evaluation of fixed or operable skylights, with plastic glazing and frames and sash members of wood, steel, plastic and homogeneous (not thermally broken, poured-and-debridged members) aluminum construction. For purposes of this criteria, fiberglass-reinforced plastic is considered to be a plastic. This criteria is applicable to curb mount, deck mount and tubular skylights installed in accordance with IBC Sections 2405 and 2610 and IRC Section R308.6. The tubular skylights are limited to installations in nonfire-resistance-rated construction. Skylights with plastic or wood frames are limited to buildings permitted to be of combustible construction.

#### A1.3 Codes and Reference Documents:

**A1.3.1** 2006 *International Building Code*® (IBC), International Code Council.

**A1.3.2** 2006 *International Residential Code*® (IRC), International Code Council.

**A1.3.3** AAMA/WDMA/CSA 101/I.S.2/A440-05 (A440), Standard/Specification for Windows, Doors, and Unit Skylights, American Architectural Manufacturers Association, Window and Door Manufacturers Association, and Canadian Standards Association.

**A1.3.4** ANSI Standard Z35.1 - 1972, American National Standards Institute.

**A1.3.5** Aluminum Design Manual, ADM 1-00, The Aluminum Association.

**A1.3.6** ASTM D256-93a, Test for Impact Resistance of Plastic and Electrical Insulating Materials, ASTM International.

**A1.3.7** ASTM D 618-61 (1981), Methods for Conditioning Plastics and Electrical Insulating Materials, ASTM International.

**A1.3.8** ASTM D 635-03, Test Method for Rate of Burning and/or Extent and Time of Burning of Self-Supporting Plastics in a Horizontal Position, ASTM International.

**A1.3.9** ASTM D 638-01, Test Method for Tensile Properties of Plastics, ASTM International.

**A1.3.10** ASTM D 790-86, Test Methods for Flexural Properties of Unreinforced and Reinforced Plastics and Electrical Insulating Materials, ASTM International.

**A1.3.11** ASTM D 1435-99, Practice for Outdoor Weathering of Plastics, ASTM International.

**A1.3.12** ASTM D 1929-96 (2001)<sup>e01</sup>, Test Method for Ignition Properties of Plastics, ASTM International.

**A1.3.13** ASTM D 2559-92, Specification for Adhesives for Structural Laminated Wood Products for Use under Exterior (Wet Use) Exposure Conditions, ASTM International.

**A1.3.14** ASTM D 2565-99, Practice for Operating Xenon Arc-Type Light Exposure Apparatus With and Without Water for Exposure of Plastics, ASTM International.

**A1.3.15** ASTM D 2843-99 (2004), Test Method for Density of Smoke from the Burning or Decomposition of Plastics, ASTM International.

**A1.3.16** ASTM D 4226-85, Test Method for Impact Resistance of Rigid Poly (Vinyl Chloride) (PVC) Building Products, ASTM International.

**A1.3.17** ASTM D 4329-99, Practice for Fluorescent UV Exposure of Plastics, ASTM International.

**A1.3.18** ASTM D 4364-94, Practice for Performing Accelerated Outdoor Weathering of Plastics Using Concentrated Natural Sunlight, ASTM International.

**A1.3.19** ASTM D 4803-93, Test Method for Predicting Heat Buildup in PVC Building Products, ASTM International.

**A1.3.20** ASTM E 84-04, Test Method for Surface Burning Characteristics of Building Materials, ASTM International.

**A1.3.21** ASTM E 108-04, Standard Test Method for Fire Tests of Roof Coverings, ASTM International.

**A1.3.22** ASTM E 283-04, Test Method for Determining the Rate of Air Leakage Through Exterior Windows, Curtain Walls and Doors Under Specified Pressure Differences Across the Specimen, ASTM International.

**A1.3.23** ASTM E 330-02, Test Method for Structural Performance of Exterior Windows, Curtain Walls, and Doors by Uniform Static Air Pressure Difference, ASTM International.

**A1.3.24** ASTM E 547-00, Test Method for Water Penetration of Exterior Windows, Skylights, Doors, and Curtain Walls by Cyclic Static Air Pressure Difference, ASTM International.

**A1.3.25** ASTM G 153-00a, Standard Practice for Operating Enclosed Carbon Arc Light Apparatus for Exposure of Nonmetallic Materials, ASTM International.

**A1.3.26** UL 746C (November 29, 2001), Standard for Polymeric Materials—Use in Electrical Equipment Evaluations, Underwriters Laboratories, Inc.

**A1.3.27** UL 790-04, Test Method for Fire Resistance of Roof Covering Materials, Underwriters Laboratories Inc.

#### A1.4 Definitions:

**A1.4.1 Curb Mount Skylights:** Skylights designed to be installed on a curb attached to the roof structure.

**A1.4.2 Deck Mount Skylights:** Skylights designed to be

## PROPOSED REVISIONS TO THE ACCEPTANCE CRITERIA FOR PLASTIC GLAZED SKYLIGHTS

installed directly on the roof structure without the need for a curb.

**A1.4.3 Operable Skylight:** A skylight which is intended to be opened and closed.

**A1.4.4 Tubular Skylights:** Skylights that consist of an exterior glazing, glazing support base (frame), 6- to 24-inch-diameter (152 to 610 mm) reflective tube (used to transmit light from the exterior glazing to the ceiling opening), and a ceiling adaptor and light diffuser at the ceiling.

**A1.4.5 Skylight Components:** Components of the skylights including the glazing, glazing retainer, frame or glazing support base, sash and fasteners. Components of tubular skylights also include a reflective tube, ceiling adaptor and diffuser.

**A1.4.6 Structural Test Pressure:** The test pressure (load) that is applied to the test specimen to determine structural load capacity. The structural test pressure (load) shall be a minimum of the allowable load multiplied by a safety factor. See Section A3.1.5.4 for applicable safety factors.

**A1.4.7 Excessive Deflection:** Excessive deflection is dome deflection that continues to increase without a corresponding increase in load.

**A1.4.8 Permanent Deflection:** The inability of any points where deflection is measured to return to within "D" inch(es) of their original positions within five minutes of removal of the load. "D" is equal to 1 percent of the longest side of the skylight.

### A2.0 BASIC INFORMATION

**A2.1 General:** The following information shall be submitted:

**A2.1.1 Product Description:** Complete information concerning the skylights shall be in the quality documentation required in Section A5.0 and shall include dimensions, configuration, component specifications (including glazing type, thickness, manufacturer's name and product designation), and manufacturing process. The information on the skylights shall include the following:

**A2.1.1.1** Generic or trade name.

**A2.1.1.2** Manufacturer's catalog or model number.

**A2.1.1.3** Outside curb dimensions.

**A2.1.1.4** Inside curb dimensions.

**A2.1.1.5** Dimensioned section profiles of skylight components such as the frame and glazing retainer.

**A2.1.1.6** Description of the materials, including physical properties of the materials from which the skylight components are manufactured, such as the frame glazing retainer and fasteners.

**A2.1.1.7** Thickness, prior to thermoforming, of plastic glazing material, for each skylight size.

**A2.1.1.8** Dome rise above the horizontal plane of the exterior face of the support frame, for each skylight size.

**A2.1.1.9** Description of shape of dome.

**A2.1.1.10** Dimensioned drawings of assembled skylight.

**A2.1.1.11** Description of adhesive(s) used, if any, to adhere wood components, including a description of the curing method.

**A2.1.2 Installation Instructions:** Installation instructions with scaled drawings of skylight mounting details, including clearances; type, spacing and quantity of fasteners; caulking and other information associated with installation.

**A2.1.3 Identification:** A description of the method of field identification of the skylight.

**A2.1.3.1 General:** A permanent label, conspicuously located on each skylight, shall bear the manufacturer's name and address, model number, evaluation report number, plastic classification (CC1 or CC2) of the plastic glazing, thickness of plastic glazing material prior to thermoforming, allowable loads and the name or logo of the inspection agency.

**A2.1.3.2 Safety Labeling:** Skylights shall bear a warning label complying with Class 1, ANSI Standard Z35.1, specifications for accident prevention signs, similar to the following, with signal and key words at least 1/4 inch high;



**A2.2 Testing Laboratories:** Testing laboratories shall comply with Section 2.0 of the ICC-ES Acceptance Criteria for Test Reports (AC85) and Section 4.2 of the ICC-ES Rules of Procedure for Evaluation Reports.

**A2.3 Test Reports:** Test reports shall comply with AC85, and shall include the information specified in A440 Section 5.4 and the following information:

**A2.3.1 General:**

**A2.3.1.1** Statements regarding sampling of the test specimens consistent with Section A2.4.

**A2.3.1.2** Verification that a qualified representative of the testing laboratory determined that the specimens complied with drawings and descriptions set forth in the report of tests.

**A2.3.1.3** Detailed drawings of the skylight, showing dimensioned section profiles, material specifications for retaining frame and curb, and any other pertinent construction details. Any modification of skylights to obtain reported values shall be noted on drawings.

**A2.3.1.4** Verification that a qualified representative of the testing laboratory witnessed installation of the test specimens and that the installation complied with the published instructions of the skylight manufacturer.

**A2.3.1.5** Pertinent data, such as fastener size, type and spacing, and maximum gap between the skylight frame and the curb for curb-mounted skylights, shall be observed and noted.

**A2.3.2 Reports of Load Tests:**

**A2.3.2.1** Tabulation of test load increments.

**A2.3.2.2** Duration of test loads.

## PROPOSED REVISIONS TO THE ACCEPTANCE CRITERIA FOR PLASTIC GLAZED SKYLIGHTS

**A2.3.2.3** Written account of observations during and after tests, including the visual observation of each load increment; loads that produce inversion of the dome to, or beyond, the horizontal plane of the exterior face of the support frame; and permanent deformation at locations specified for each skylight tested.

**A2.3.2.4** Mode of failure for each tested skylight.

**A2.3.2.5** Statement from the testing agency indicating that tests were conducted in accordance with this criteria, or a full description of any deviations.

### **A2.3.3 Reports of Water-resistance Tests:**

**A2.3.3.1** Slope of tested skylights.

**A2.3.3.2** Water-application rates.

**A2.3.3.3** Record of all points of water penetration on the interior face of the test specimens.

**A2.3.3.4** Statement from the testing laboratory indicating success or failure of the test specimen.

**A2.4 Product Sampling:** Sampling of the skylights for tests under Part A of this criteria shall comply with the independent sampling requirements of Section 3.1 of AC85.

## **A3.0 TEST AND PERFORMANCE REQUIREMENTS**

### **A3.1 Sequential Testing:**

**A3.1.1 General:** Testing shall be conducted on one skylight of each skylight model in the sequence indicated in Sections A3.1.2 through A3.1.5. (See A440 Section 5.1.1.) Skylight test specimens shall be mounted in a manner consistent with the submitted installation instructions. (See Section A2.1.2.)

The air infiltration, water penetration and uniform load tests on operable skylights shall be performed with the skylights in the closed and latched position.

Prior to the conducting of the uniform load tests of Section A3.1.5, inner domes and/or flat glazing panels shall either be removed or holes of sufficient size and quantity shall be drilled in all but the outer dome to enable the pressure on both sides of each inner dome or flat glazing panel to be equalized. The test pressure differential shall be measured across the outer dome. Testing shall be performed on the largest skylight to be included in the evaluation report. For recognition of smaller skylights, with the same allowable load as the tested skylights, the smaller skylights shall be of the same construction with the same glazing thickness prior to thermoforming and have similar plastic glazing configuration (for example, dome or pyramid); glazing height-to-least width ratio (percent rise); skylight length-to-width aspect ratio; and fastener spacing and type.

### **A3.1.2 Operating Force for Operable Skylights:**

**A3.1.2.1 Procedure:** If the skylight is an operable skylight, the skylight shall be tested in accordance with A440 Section 5.3.1, with excessive operating force as defined in Section 5.3.1 of A440 deemed to be failure. The A440 permission to adjust the tested specimen prior to retesting and permission to select a new test specimen if the skylight has excessive operating force is not allowed under this acceptance criteria.

**A3.1.2.2 Conditions of Acceptance:** The skylight shall comply with the requirements for roof windows as outlined in A440 Table 5.

### **A3.1.3 Air Infiltration:**

**A3.1.3.1 Procedure:** The skylight shall be tested in accordance with A440 Section 5.3.2. The test pressure shall be 1.57 psf (75 Pa).

**A3.1.3.2 Conditions of Acceptance:** The skylight shall comply with the requirements outlined in A440 Table 6, with a maximum allowable air leakage of 0.3 cfm/ft<sup>2</sup> (1.5 L/s·m<sup>2</sup>).

### **A3.1.4 Water Penetration:**

**A3.1.4.1 Procedure:** The skylight shall be tested in accordance with A440 Section 5.3.3, except as amended by this criteria. The skylight shall be tested at the lowest slope for which recognition is sought. Testing shall be in accordance with ASTM E 547, with an air pressure differential of 2.92 psf (140 Pa) or 15 percent of the design load, whichever is greater. The water penetration test shall consist of four test cycles, with each cycle consisting of five minutes with the pressure applied and one minute with the pressure released, during which the water spray is continuously applied for a total test duration of 24 minutes, minimum.

Where the manufacturer offers or specifies an interior insect screen, the water penetration resistance test shall be performed with the insect screen removed.

**A3.1.4.2 Conditions of Acceptance:** There shall be no water leakage on the interior side of the tested skylight.

### **A3.1.5 Uniform Load Testing:**

**A3.1.5.1 General:** Test equipment for superimposed loading shall be adequate to develop anticipated ultimate loads. If loading is not carried to failure, the highest value achieved will be considered the ultimate. Application of uniform loads shall be by differential air pressure [pounds per square foot (Pascals)] exerted with a vacuum or pressure pump.

Deflection-measuring devices, as required by Section 11.2.2 of ASTM E 330, shall be installed to measure deflection of the skylight framing members.

Additionally, for domed skylights, measurements shall be perpendicular to the tangent of the original surface. For "free-blown" units, measuring devices must be located at the highest point and at points located halfway up the dome from the midpoint of each side. For "pyramids," measuring devices shall be located at the uppermost point and at points halfway down each rib.

For flat skylights, measurements shall be made at the center of the skylight and at the midpoint of each side. The deflection gauges shall be installed so that the deflection of the plastic glazing material can be measured without being influenced by possible movement of, or movement within, the test unit or supporting members.

Prior to the conducting of the uniform load test, the skylights shall be conditioned in accordance with Procedure A of ASTM D 618.

### **A3.1.5.2 Uniform Load Deflection Test:**

**A3.1.5.2.1 Procedure:** Load test procedures shall comply with Procedure A of ASTM E 330, with the following modifications:

a. A load equal to one-half the anticipated allowable load shall be applied and held for one minute. Deflection readings shall be taken. The load shall then be released and deflection readings shall be taken after a recovery period of not less than one minute nor more than five minutes at zero load. The test specimen shall be evaluated for permanent

## PROPOSED REVISIONS TO THE ACCEPTANCE CRITERIA FOR PLASTIC GLAZED SKYLIGHTS

damage.

b. The anticipated allowable load shall then be applied and held for one minute. Deflection readings shall be taken. The load shall then be released; deflection readings shall be taken after a recovery period of not less than one minute nor more than five minutes at zero load. The test specimen shall be evaluated for permanent damage.

c. The test loads shall be applied as positive pressures and then as negative pressures. The sequence of loading shall be permitted to be reversed at the option of the testing laboratory.

**A3.1.5.2.2 Conditions of Acceptance:** There shall be no permanent damage to the glazing, fasteners, hardware parts, support arms or actuating mechanisms, disengagement, or any other damage which causes the operable skylights to become inoperable.

### A3.1.5.3 Uniform Load Structural Test:

**A3.1.5.3.1 Procedure:** Load test procedures shall comply with Procedure A of ASTM E 330, with the following modifications:

a. A load equal to one-half the structural test pressure (see Section A1.4.6) shall be applied and held for one minute. The load shall then be released and permanent deflection readings shall be taken after a recovery period of not less than one minute nor more than five minutes at zero load. The test specimen shall be evaluated for permanent damage.

b. The structural test pressure shall then be applied and held for one minute. The load shall then be released; permanent deflection readings shall be taken after a recovery period of not less than one minute nor more than five minutes at zero load. The test specimen shall be evaluated for permanent damage.

c. The test loads shall be applied as positive pressures and then as negative pressures. The sequence of loading shall be permitted to be reversed at the option of the testing laboratory.

d. As an option, tests may be carried to failure to gain more information on frame capacity by increasing loads in maximum increments of 10 psf (478 Pa), with each load held for one minute.

**A3.1.5.3.2 Conditions of Acceptance:** There shall be no glazing breakage (such as cracking, crazing, creasing or strain marring), deglazing of the skylight, or permanent damage to fasteners, hardware parts, support arms or actuating mechanisms, disengagement, or any other damage which causes operable skylights to become inoperable. There shall be no excessive or permanent deflection of the glazing of skylights with domed glazing, except as provided in Section ~~A3.4~~ **A3.3**. The deflection of the glazing of flat glazed skylights shall not exceed L/20 with the structural test pressure applied to the specimen. There shall be no permanent deflection of any frame member in excess of  $1/250$  of its span.

**A3.1.5.4 Safety Factors:** The safety factor which shall be applied to the allowable load to establish the structural test pressure, shall comply with the following:

1. Positive or inward pressure: 3.0
2. Negative or outward pressure: 2.0

**A3.2 Additional Uniform Load Testing:** In addition to the

uniform load tests required under Section A3.1, a minimum of two additional, identical skylights shall be subjected to, and comply with, the uniform load tests of Section A3.1.5. These skylights shall not be the specimens tested under Section A3.1 that have been reglazed. The requirements in Section A3.1.1 regarding test specimen installation and pressure differential across the outer dome are applicable to these additional uniform load tests.

**Exemptions:** The additional uniform load tests of this criteria section (Section A3.2) are not required under either of the two following conditions:

1. The results of the positive load test of Section A3.1 may be used when the ultimate load exceeds 60 psf (2.874 kN/m<sup>2</sup>) and the allowable roof live load is limited to a maximum of 20 psf (0.958 kN/m<sup>2</sup>).

2. The results of the negative load test of Section A3.1 may be used when the ultimate load exceeds 60 psf (2.874 kN/m<sup>2</sup>) and the allowable wind uplift load is limited to a maximum of 20 psf (0.958 kN/m<sup>2</sup>).

~~**A3.3 Additional Air Infiltration Tests:** If the skylights tested under Section A3.1 do not have the largest perimeter length-to-glazing area ratio, then the largest skylight with the largest perimeter length-to-glazing area ratio shall be subjected to, and comply with, the air infiltration test of Section A3.1.3.~~

### ~~A3.4~~ **A3.3 Skylights With Excessive Dome Deflection:**

~~**A3.4.1 A3.3.1 General:** Compliance with this criteria section (Section ~~A3.4~~ **A3.3**) is required for skylights which demonstrate excessive dome deflection at the structural test pressure in the uniform load testing of Sections A3.1.5 and A3.2.~~

~~**A3.4.2 A3.3.2 Uniform Load:** The skylights tested in accordance with Sections A3.1.5 and A3.2 must demonstrate compliance with the conditions of acceptance in Section A3.1.5.3.2, except that the load that causes excessive deflection shall be equal to, or exceed, 1.5 times the allowable load. Upon release of the ultimate load, the dome shall return, unassisted, to within "D" inch(es) of its original configuration within five minutes of load removal. "D" is equal to 1 percent of the longest side of the skylights.~~

~~**A3.4.3 A3.3.3** The additional plastic glazing weathering tests of Section A4.1.4 shall be conducted.~~

~~**Exception:** In lieu of conducting the additional plastic glazing weathering tests of Section ~~A3.4~~ **A4.1.4**, skylights used as test specimens under Sections A3.1.5 and A3.2 shall be installed and exposed to natural weathering for a minimum of five years prior to testing. The test specimens shall be representative of the product under consideration, and the location of the skylights shall be approved prior to removal by the testing agency. As an alternate to the natural weathering, the skylights may be weathered by accelerated weathering methods, equivalent to the requirements specified in Section A4.1.2.2.~~

~~**A3.4.4 A3.3.4 Cyclic Load Tests:** One skylight specimen shall be subjected to a positive cyclic load test with the following requirements:~~

~~**A3.4.4.1 A3.3.4.1** Uniform loads shall be applied by differential air pressure exerted on the skylight by a vacuum or pressure pump.~~

~~**A3.4.4.2 A3.3.4.2** Seventy-five percent of the allowable load shall be applied and held for one minute. Upon release of pressure, initial readings shall be recorded after a recovery~~

## PROPOSED REVISIONS TO THE ACCEPTANCE CRITERIA FOR PLASTIC GLAZED SKYLIGHTS

period of not more than five minutes at zero load.

**A3.4.4.3 A3.3.4.3** Full test load (test load = allowable load  $\times$  1.5) shall be applied and maintained for one minute, while visual observations are recorded. Pertinent deflection readings shall be taken prior to the positive loading being increased to the ultimate uniform load (ultimate uniform load = allowable load  $\times$  3.0). The ultimate uniform load shall be maintained for one minute, while visual observations are made and deflections recorded.

**A3.4.4.4 A3.3.4.4** Pressure shall be reduced to zero. The dome shall return, unassisted, to within "D" inch(es) (mm) of its unloaded configuration. (For explanation of the "D" dimension, see Section **A3.4.2 A3.3.2**.) After a recovery period of not more than five minutes, the test shall be repeated for a minimum of 25 cycles.

**A3.4.4.5 A3.3.4.5** Failure due to cyclic loading is defined as plastic cracking, crazing, creasing, or strain marring; or glazing disengagement or permanent deflection. In addition, excessive deflection of the plastic dome shall not occur at a positive load equal to, or less than, 1.5 times the allowable load.

**A3.5 A3.4** Evidence that the allowable load capacity of the fasteners attaching the skylight to the roof structure equals, or exceeds, the allowable wind uplift pressure determined under Section A3.1. In the absence of code-recognized or nationally recognized allowable loads for fasteners, small-scale fastener tests are necessary. Prior to tests being conducted, a suggested test program should be submitted to ICC-ES for review.

### **A3.6 A3.5 Distributed Load Tests:**

**A3.6.1 A3.5.1 Procedure:** Operable skylights shall be tested in accordance with the distributed load test described in Section 5.3.6.6.2 of A440. The test shall be conducted on one of each of the operable skylight models having the same size and design as the skylights tested under Section A3.1.

**A3.6.2 A3.5.2 Condition of Acceptance:** The specimens must comply with the conditions of acceptance in Section 5.3.6.6.2 of A440, resisting a minimum load of 5.0 psf.

**A3.7 A3.6** Weathering (outdoor or weatherometer) and strength tests of the plastic glazing material shall be conducted in accordance with Section A4.1. The skylight report applicant does not need to submit these reports of tests if the plastic glazing material is recognized in a current ICC-ES evaluation report as complying with these requirements.

**A3.8 A3.7** The plastic glazing material shall be demonstrated to comply with IBC Section 2606.4. Reports of tests that are needed are self-ignition temperature (minimum 650°F when tested in accordance with ASTM D 1929); smoke-developed index (ASTM E 84 or ASTM D 2843); and plastic combustibility classification (Class CC1 or Class CC2 tested in accordance with ASTM D 635). The skylight report applicant does not need to submit these reports of tests, if the plastic glazing material is recognized under a current ICC-ES evaluation report for these requirements.

**A3.9 A3.8** A Class B Burning-brand test is required under the following conditions:

**A3.9.1 A3.8.1** On flat or corrugated plastic skylights mounted at slopes less than 4:12. See Section A4.2. For purposes of this criteria, this minimum roof slope is applicable to skylights recognized for use under the IBC and

IRC.

**A3.9.2 A3.8.2** On dome-shaped skylights that rise above the mounting flange a distance less than the dome rise requirements of IBC Section 2610.3. For purposes of this criteria, the dome rise requirements of IBC Section 2610.3 are applicable to skylights recognized for use under the IRC. See Section A4.2.

**A3.9.3 A3.8.3** On any skylight with a plastic skylight glazing exposed edge that is not protected with metal or other noncombustible material. See Section A4.3.

**Exception:** Testing in accordance with Section A4.3 is not required if the skylight is limited to installations where nonclassified roof coverings are permitted.

**A3.10 A3.9 Adhesives:** Adhesive for structural applications of skylight wood components shall comply with ASTM D 2559. Adhesives of skylight wood components for other uses shall comply with A440 Section 6.3.2.2.

**A3.11 A3.10** Weathering and strength tests of the plastic material of skylight frames and glazing retainer caps shall be conducted in accordance with Section A4.4. These tests are not required if the plastic material is protected from exposure to ultraviolet light by metal cladding.

**A3.12 A3.11** Temperature cycling tests of the plastic material of skylight frames and glazing retainer caps shall be conducted in accordance with Section A4.5.

**A3.13 A3.12 Deformation/Creep Tests:** Plastic frames that do not directly transfer loads axially to the supporting sash are beyond the scope of these criteria. When plastic frames transfer loads eccentrically to the supporting sash, flexural deflection of the frame can occur. The proponent must investigate and determine the effect of deformation under long-term loads or creep on product performance. The proponent must submit a proposed test program to ICC-ES for review prior to testing.

**A3.14 A3.13** Reports of tests of the material of the tube of tubular skylights shall demonstrate compliance with IBC Section 803.1 or 803.2.

**A3.15 A3.14** Reports of tests conducted in accordance with UL 746 C on tubular skylights installed in accordance with the manufacturer's instructions shall demonstrate that the tube passes the 5 lb-ft (6.78 N · m) ball impact test without cracking, product disassembly or rupture.

**A3.16 A3.15** Reports of tests shall demonstrate that the light-diffusing, plastic lens used in tubular skylights complies with IBC Sections 2606.4 and 2606.7.2.

## A4.0 TEST METHODS

### A4.1 Weathering (Outdoor and Weatherometer) and Strength Tests:

**A4.1.1** The tests, procedures and standards described in Section A4.1 are applicable to the exterior light-transmitting plastic glazing materials of all skylights. Tests shall be conducted in accordance with either Section A4.1.2 or Section A4.1.3. Dome skylights recognized in accordance with Section **A3.4 A3.3** shall also be tested in accordance with Section A4.1.4.

**A4.1.2** Testing under this section (Section A4.1.2) is applicable to any plastic glazing material.

**A4.1.2.1** For each plastic material, Type I tensile specimens are cut from the plastic material and tested in accordance with ASTM D 638. For materials that are

## PROPOSED REVISIONS TO THE ACCEPTANCE CRITERIA FOR PLASTIC GLAZED SKYLIGHTS

nonisotropic (physical properties in the machine direction that are different from the physical properties in the cross-machine direction), there should be a total of 20 specimens: five specimens for each direction for the control specimens, and five specimens for each direction for the weathered specimens. For materials that are isotropic (consistent physical properties in both directions), there need be only 10 total specimens. Five of the specimens shall be used as control and the remaining five specimens are to be exposed to the exposure testing of Section A4.1.2.2 prior to tension testing. Either the tested materials shall have the thickness intended for end use, or the tests can be conducted on the thinnest and thickest material thicknesses of the range of thicknesses intended for end use.

**A4.1.2.2** The exposure specimens are to be tested in accordance with ASTM D 2565, utilizing cycle No. 2. Exposure duration shall be 3000 hours.

As an alternative, the exposure specimens may be exposed for five years in southern Florida at a 45-degree, south-facing exposure.

**A4.1.2.3** Control and weathered plastic specimens shall be examined under 5× magnification. Surface changes such as chalking, cracking, checking, crazing, or erosion, or other characteristics that might affect performance of the plastic, are unacceptable.

**A4.1.2.4** The tensile properties of the exposed and control specimens shall be determined in accordance with ASTM D 638.

**A4.1.2.5** For acceptance, the average tensile strength and modulus of elasticity of the exposed specimens shall not be less than 90 percent of the average values of the control specimens. Tensile strength is defined under this criteria as either the tensile strength at yield (for materials that exhibit a distinct yield point, i.e., ductile materials) or as the tensile strength at break (for materials with no distinct yield point, i.e., non-ductile materials).

**A4.1.3** Testing under this section is limited to those plastic glazing materials that break upon impact in the Charpy Test and to those plastic glazing materials that have completed testing before July 2002.

**A4.1.3.1** Two 3-inch-by-9-inch (76 mm by 229 mm) panels are required for each thickness of plastic material. One panel shall be treated as control.

**A4.1.3.2** For each thickness of plastic material, one panel shall be subjected to accelerated weathering tests for 2,000 hours in accordance with ASTM G 153. The operating cycle shall be Cycle 1 set forth in Table X1.1 of ASTM G 153.

As an alternate to the 2,000-hour, ASTM G 153, carbon-arc weathering, the xenon-arc weathering requirements specified in Section 24.211.3.3 of UBC Standard 24-2 may be used; or the plastic material may either be exposed to 36,805 Langleys of ultraviolet irradiance at an angle 90 degrees from the horizontal in accordance with Procedure B of ASTM E 838, or exposed for five years in southern Florida, with a southern exposure, at a 45-degree angle.

**A4.1.3.3** Control and weathered plastic specimens shall be examined under 5× magnification. Surface changes such as chalking, cracking, checking, crazing, or erosion, or other characteristics that might affect performance of the plastic, are unacceptable.

**A4.1.3.4** Five 1/2-inch-by-5-inch (12.7 mm by 127 mm) specimens shall be cut from both the control and weathered samples, with all specimens evaluated as described in Method B, "Single Beam (Charpy-Type) Test" of ASTM D 256. Specimens shall be unnotched and tested at a span of 4 inches (102 mm). The weathered specimens shall have their exposed surface in tension.

**Note:** The Charpy Test is used solely as a means of assessing retention of mechanical properties of the plastic after weathering. It should not be considered to have any significance as a measure of the impact resistance of the product tested.

**A4.1.3.5** For acceptance, maximum loss of impact strength after weathering shall not be greater than 25 percent.

**A4.1.4** The following additional tests are required for dome skylights recognized in accordance with Section A3.4 **A3.3:**

**A4.1.4.1** Twenty representative samples of each plastic thickness shall be used, of which ten shall be held as controls and the remainder shall be weathered in accordance with Section A4.1.2.2.

**A4.1.4.2** The control and weathered plastic specimens shall be inspected under a 5× magnification, and any cracking or deleterious effects noted. Surface changes such as chalking, cracking, checking, crazing, erosion or other characteristics that might affect performance of the plastic are unacceptable.

**A4.1.4.3** One half of the control and weathered specimens shall be bent at an angle of rotation around a mandrel having a radius no larger than the minimum bend radius and the same angle of rotation of the plastic that occurs when the dome inverts in the full-scale positive load tests. Each small-scale specimen shall be bent around the mandrel a minimum of 25 times and held in the bent position for at least 1 minute. Cracking, crazing, strain marring or other characteristics that might affect performance of the weathered plastic are unacceptable.

**A4.1.4.4** Comparative tensile and elongation tests shall be conducted in accordance with ASTM D 638 on the control and weathered specimens, following the mandrel bend test. Weathered specimens, subjected to the mandrel bend test, shall have no loss in average tensile strength and a maximum elongation reduction of 20 percent.

**A4.1.4.5** Comparative flexural bending tests shall be conducted in accordance with ASTM D 790 on the control and weathered specimens. Weathered specimens shall have no loss in average flexural strength or calculated modulus of elasticity.

**A4.2 Class B Burning-brand Test Required by Section A3.9.1 or A3.9.2 A3.8.1 or A3.8.2:**

**A4.2.1** Skylights manufactured in a flat or corrugated configuration mounted at a slope less than 4:12 (33 1/3%), or skylights with a dome-shaped configuration with a rise above the mounting flange less than the dome rise requirements of IBC Section 2610.3 shall pass the Class B burning-brand test in accordance with ASTM E 108 or UL 790. The Class B brand shall be ignited as required by ASTM E 108 or UL 790. This test is to be performed on the largest size skylight in each profile and material thickness.

**A4.2.2** A Class B brand shall be placed on the surface of the plastic material at the location considered the most vulnerable. Each brand is secured to the specimen by No. 18,

## PROPOSED REVISIONS TO THE ACCEPTANCE CRITERIA FOR PLASTIC GLAZED SKYLIGHTS

B. & S. gage soft wire. A second brand shall be applied after all burning resulting from the first brand has ceased.

**A4.2.3** Wind must be directed on the brand at the most critical direction, as determined by the testing agency.

**A4.2.4** Each test shall be continued either until the brand is consumed and all evidence of flame, glow and smoke has disappeared from both the exposed surface of the material being tested and the underside of the test deck, or until failure occurs. The results of tests in which the brands do not show progressive and substantially complete consumption after application to the skylight are to be disregarded.

**A4.3 Class B Burning-brand Test Required by Section A3.9.3 A3.8.3:** The following are necessary for Class B burning-brand tests required by Section ~~A3.9.3~~ **A3.8.3:**

**A4.3.1** Skylights with plastic lights or domes not protected by metal or other noncombustible material shall be subjected to a burning-brand test procedure, shown in Figure 1.

**A4.3.2** The Class B burning-brand shall be ignited as required by ASTM E 108 or UL 790, as applicable.

**A4.3.3** The burning-brand shall self-extinguish without transferring the fire to the dome.

**A4.4 Weathering (Outdoor or Weatherometer) and Strength Tests:** The following are required for the weathering and strength tests of plastic frames and glazing retainer caps:

**A4.4.1** Ten 1-inch-by-6-to-10-inch (25.4 mm by 152 to 254 mm) samples are cut from the plastic. Cut edges may be protected. Half of the samples shall be treated as control.

**A4.4.2** Five of the samples shall be subjected to one of the following weathering conditions. The surface exposed in the test shall represent the surface exposed in the end use.

**A4.4.2.1** Accelerated weathering tests for 2,000 hours in accordance with ASTM Specification G 153. The operating schedule shall be Cycle 1 set forth in Table X1.1 of ASTM G 153.

**A4.4.2.2** Accelerated weathering tests, in accordance with ASTM Specification D 2565. Exposure shall be for 2,900 hours with exposure Cycle 1.

**A4.4.2.3** Exposure to 36,805 Langleys of ultraviolet (UV) irradiance in accordance with Procedure B of ASTM D 4364 using Spray Cycle 1.

**A4.4.2.4** Outdoor weathering per ASTM D 1435 with exposure for five years with a southern exposure at a 45-degree angle in a hot humid climate, a hot arid climate and a northern industrial climate.

**A4.4.2.5** Accelerated weathering tests according to ASTM D 4329. Exposure shall be for 2,000 hours with cycles of 8 hours UV at 158°F (70°C) followed by four hours condensation at 104°F (40°C).

**A4.4.3** Both the control and weathered samples shall be evaluated to assess retention of mechanical properties of the plastic after weathering by one of the following two methods:

**A4.4.3.1** Rigid PVC plastics subject to outdoor weathering in accordance with Section A4.4.2.4 shall be evaluated as described in Procedure B of ASTM D 4226.

For acceptance, the minimum impact strength after two years of outdoor weathering shall be not less than 0.60 in.-lb./mil (2.67 N-m/mm). In addition, there shall be no visible signs of cracking or chipping after five years. Alternatively, the plastics may be evaluated as described in Section A4.4.3.2 of these criteria.

**A4.4.3.2** Other plastics, such as fiberglass, shall be evaluated as described in ASTM D 638 and ASTM D 790. Any loss in mechanical properties shall be accounted for in the design of the plastic frame. The allowable load shall be determined according to Section A3.1 of this criteria, with reduction to accommodate any loss in mechanical properties.

### A4.5 Temperature Cycling Tests:

**A4.5.1 Specimens:** A representative sample skylight frame with glazing shall be subjected to 24 consecutive cycles of this test. The specimens shall be installed in a rigid wood frame simulating the field installation procedure recommended by the manufacturer. The test decks shall be installed at the minimum horizontal slope recommended for recognition. Test specimens shall be mounted in a compartment so one side of the specimens can be maintained at 73.4°F (23°C) throughout testing. The apparatus shall allow variable temperatures to the other side (weather side) of the specimen.

**A4.5.2 Procedure:** During the first hour, the weather side temperature shall be decreased from 73.4°F (23°C) to -22°F (-30°C) and then maintained at -22°F (-30°C) for one hour. During the third hour, the weather side temperature shall be increased to 73.4°F (23°C). In the next hour the weather side temperature shall be raised to 122°F (49°C) and then maintained for an additional hour. During the two-hour period, radiant heat shall be applied to the weather side of the specimens. The radiant heat must impose, and maintain for one hour, a temperature on the frame equivalent to the sum of the maximum heat build-up plus the ambient test temperature of 122°F (49°C).

Maximum heat buildup shall be determined in accordance with ASTM D 4803 using horizontal samples and using the darkest colors being recognized.

During the sixth hour, the radiant heat source shall be turned off and the temperature of the weather side compartment lowered to 73.4°F (23°C). The exposures may be suspended between cycles, such as on weekends or holidays, provided the samples are maintained at 73.4°F (23°C).

**A4.5.3 Conditions of Acceptance:** At the conclusion of 24 cycles, the product shall have no crazing, cracking or other deleterious surface or joint changes at the end of the test. Additionally, there shall be no sign of failure or distress at fastener locations or at skylight frame corners.

### A5.0 QUALITY CONTROL

**A5.1** The skylights shall be manufactured under an approved quality control program with inspections by an inspection agency accredited by the International Accreditation Service (IAS) or otherwise acceptable to ICC-ES.

**A5.2** Quality documentation complying with the ICC-ES Acceptance Criteria for Quality Documentation (AC10) shall be submitted.

### A6.0 EVALUATION REPORT RECOGNITION

**A6.1** The evaluation report shall include the maximum

**PROPOSED REVISIONS TO THE ACCEPTANCE CRITERIA FOR PLASTIC GLAZED SKYLIGHTS**

allowable positive and negative loads on the skylights reported in pounds per square foot (psf).

~~A6.2 The evaluation report shall indicate compliance with the air infiltration conditions of acceptance (see Section A3.1.3.2).~~

**A6.3 A6.2** The evaluation report shall reference the specific published installation instructions or installation drawings, including applicable dates and revision number of the installation instructions or drawings.

**A6.4 A6.3** The evaluation report shall indicate that the skylights are to be installed in accordance with IBC Sections 2405 and 2610 and IRC Section R308.6.

**A6.5 A6.4** Evaluation reports on plastic framed skylights include a statement that the skylights with plastic frames are limited to installations where a roof covering classification is not required.

## PART B

# UNIFORM BUILDING CODE, BOCA NATIONAL BUILDING CODE AND STANDARD BUILDING CODE

### B1.0 INTRODUCTION

**B1.1 Purpose:** The purpose of Part B of this criteria is to establish requirements for recognition of plastic skylights in ICC Evaluation Service, Inc. (ICC-ES), evaluation reports under Sections 2409 and 2603 of the 1997 *Uniform Building Code*<sup>™</sup> (UBC), Sections 2407, 2405.3.2 and 2404.6 of the 1999 *Standard Building Code*<sup>®</sup> (SBC) and Sections 2405.0 and 2608.0 of the BOCA<sup>®</sup> *National Building Code/1999* (BNBC).

The reason for development of this criteria is to establish guidelines for the evaluation of plastic glazed skylights since the UBC, SBC and BNBC do not include qualification, design and quality requirements for plastic glazed skylights.

Any specified test may be waived if performance of the skylights submitted for recognition is predictable based on accepted engineering principles.

**B1.2 Codes and Reference Documents:** Where standards are referenced in this criteria, the standards shall be applied consistently with the code (UBC, SBC or BNBC) upon which recognition of the skylights is based. Editions of the standards applicable to each code are noted below or are summarized in Table 1.

**B1.2.1** 1997 *Uniform Building Code*<sup>™</sup> (UBC).

**B1.2.2** BOCA *National Building Code/1999* (BNBC).

**B1.2.3** 1999 *Standard Building Code* (SBC).

**B1.2.4** ANSI Standard Z35.1 - 1972, American National Standards Institute.

**B1.2.5** Aluminum Design Manual, October 1994, The Aluminum Association.

**B1.2.6** ASTM D 618, Method for Conditioning Plastics and Electrical Insulating Materials, ASTM International.

**B1.2.7** ASTM D 635, Test Method for Rate of Burning and/or Extent and Time of Burning of Self-Supporting Plastics in a Horizontal Position, ASTM International.

**B1.2.8** ASTM D 638, Test Method for Tensile Properties of Plastics, ASTM International.

**B1.2.9** ASTM D 790, Test Methods for Flexural Properties of Unreinforced and Reinforced Plastics and Electrical Insulating Materials, ASTM International.

**B1.2.10** ASTM D 1929, Test Method for Ignition Properties of Plastics, ASTM International.

**B1.2.11** ASTM D 2565, Practice for Operating Xenon Arc-Type Light Exposure Apparatus With and Without Water for Exposure of Plastics, ASTM International.

**B1.2.12** ASTM D 2843, Test Method for Density of Smoke from the Burning or Decomposition of Plastics, ASTM International.

**B1.2.13** ASTM E 84, Test Method for Surface Burning Characteristics of Building Materials, ASTM International.

**B1.2.14** ASTM E 108, Standard Test Method for Fire Tests of Roof Coverings, ASTM International.

**B1.2.15** ASTM E 330, Test Method for Structural Performance of Exterior Windows, Curtain Walls, and Doors by Uniform Static Air Pressure Difference, ASTM International.

**B1.2.16** ASTM E 331, Test Method for Water Penetration of Exterior Windows, Curtain Walls, and Doors by Uniform Static Air Pressure Difference, ASTM International.

**B1.2.17** ASTM E 838, Performing Accelerated Outdoor Weathering Using Concentrated Natural Sunlight, ASTM International.

**B1.2.18** ASTM G 153-00a, Standard Practice for Operating Enclosed Carbon Arc Light Apparatus for Exposure of Nonmetallic Materials, ASTM International.

**B1.2.19** UL 790, Test Method for Fire Resistance of Roof Covering Materials, Underwriters Laboratories Inc.

### B1.3 Definitions:

**B1.3.1 Excessive Deflection:** Excessive deflection is dome deflection that continues to increase without a corresponding increase in load.

**B1.3.2 Permanent Deflection:** The inability of any points where deflection is measured to return to within "D" inch(es) of their original position within five minutes of removal of the load. "D" is equal to 1 percent of the longest side of the unit.

**B1.3.3 Plastic Skylight:** A prefabricated unit consisting in whole or in part of translucent or transparent plastic over a roof opening for admitting light. Plastic skylights shall comply with UBC Sections 2409 and 2603, SBC Sections 2407, 2405.3.2 and 2404.6, and BNBC Sections 2405.0 and 2608.0.

### B2.0 BASIC INFORMATION

**B2.1** Skylight test specimens shall be of standard manufacture and be representative (as to dimensional specifications, materials and finish) of the product for which recognition is sought. The test unit shall be mounted in a manner consistent with its intended installations.

**B2.2** Skylight descriptions shall include:

**B2.2.1** Generic or trade name.

**B2.2.2** Manufacturer's catalog or model number.

**B2.2.3** Outside curb dimension.

**B2.2.4** Inside curb dimension.

**B2.2.5** Thickness, prior to thermoforming, of plastic glazing material, for each size.

**B2.2.6** Dome rise above the horizontal plane of the exterior face of the support frame, for each size.

**B2.2.7** Materials, and the physical properties of the materials, from which the components are manufactured. The components include the dome, frame, curb, corrosion-resistant fasteners and flashing. For use under the UBC, fasteners in contact with aluminum components and separation of aluminum from dissimilar materials shall be in accordance with UBC Sections 2004.2 and 2004.3. For use under the SBC or BNBC, fasteners in contact with aluminum and separation of aluminum from dissimilar materials shall

**PROPOSED REVISIONS TO THE ACCEPTANCE CRITERIA FOR PLASTIC GLAZED SKYLIGHTS**

be in accordance with Section 6.6.1 of Part I-A or I-B of the Aluminum Design Manual.

**B2.2.8 Configuration** (e.g., flat, pyramidal, domed, corrugated).

**B2.2.9 Scaled drawings of mounting details**, including metal and wood-curb details, type and spacing of fasteners, caulking, or other information associated with installation.

**B2.2.10 Manner of field identification.** A permanent label, conspicuously located on each skylight, shall bear the manufacturer's name and address, evaluation report number, plastic classification (CC1 or CC2) and thickness of plastic glazing material prior to thermoforming.

**B2.2.11 Manufacturer's installation instructions.**

**B2.2.12 Safety labeling.** Skylights shall bear a warning label complying with Class I, ANSI Standard Z35.1 specifications for accident prevention signs, similar to the following, with signal and key words at least 1/4 inch high:

**SAFETY LABEL ILLUSTRATION**

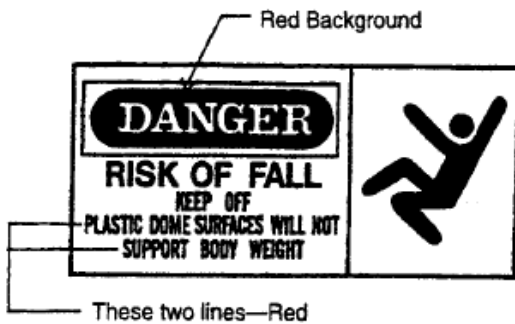

All other print to be black

**B2.3 Testing and Laboratories, Reports of Tests and Product Sampling:**

**B2.3.1 Testing Laboratories:** Testing laboratories shall comply with Section 2.0 of the ICC-ES Acceptance Criteria for Test Reports (AC85) and Section 4.2 of the ICC-ES Rules of Procedure for Evaluation Reports.

**B2.3.2 Test Reports:** Test reports shall comply with AC85. See also, Section B5.0.

**B2.3.3 Product Sampling:** Sampling of the plastic skylights and of the components of plastic skylights for tests under Part B of this criteria is permitted to comply with Section 3.2 of AC85.

**B3.0 REQUIRED DATA**

**B3.1 Uniform load tests to determine the maximum allowable loads for domed and flat skylights.** See Section B4.1.

**B3.2 Evidence that the allowable load capacity of the fasteners attaching the unit to the roof structure equals, or exceeds, the allowable wind uplift pressure determined under Section B4.1.12.** In the absence of code-recognized or nationally recognized allowable loads for fasteners, small-scale fastener tests are necessary. Prior to conducting tests, a suggested test program should be submitted to ICC-ES for

review.

**B3.3 Weathering** (outdoor and weatherometer) and strength tests. See Section B4.2.

**B3.4 Smoke-density, self-ignition temperature and burn rate/extent classification tests.** These tests may be waived, provided plastic is recognized under a current ICC-ES evaluation report. See Section B4.3.

**B3.5 A Class B Burning-brand test is required under the following conditions:**

**B3.5.1 On flat or corrugated plastic units mounted at slopes less than 4:12.** See Section B4.4.

**B3.5.2 On dome-shaped skylights that rise above the mounting flange a distance less than the dome rise requirements of UBC Section 2603.7.1 (item 2), BNBC Section 2608.3 or SBC Section 2604.6.3.**

**B3.5.3 On any skylight with an exposed edge that is not protected with metal or other noncombustible material.** See Section B4.5.

**B3.6 Water-resistance tests:** See Section B4.6.

**EXCEPTION:** In lieu of conducting water-resistance tests, independent documentation of field performance of representative units, as determined by ICC-ES, may be furnished.

**B4.0 TESTING PROCEDURE**

**B4.1 Uniform Load Tests to Determine Maximum Allowable Loads for Domed and Flat Skylights:**

**B4.1.1** The load tests are conducted on the largest unit in each profile and material thickness. Recognition of smaller units is dependent on similar dome-height-to-least-width ratios (percent rise), length-to-width aspect ratio, material thicknesses and fastener spacing and type.

**B4.1.2** The average ultimate load shall be based on at least three tests in each series.

**EXCEPTIONS:**

1. The results of two tests may be used when the higher value and lower value do not exceed their average by more than 10 percent and the lower value is used, with the required factors of safety. If the higher value and lower value exceed their average by more than 10 percent and the lower value exceeds an ultimate load of 60 psf (2.874 kN/m<sup>2</sup>), recognition of the unit may be granted, provided the allowable roof live load does not exceed 20 psf (0.958 kN/m<sup>2</sup>).

2. The results of one positive load test per largest unit size may be used when the ultimate load exceeds 60 psf (2.874 kN/m<sup>2</sup>) and the allowable roof live load does not exceed 20 psf (0.958 kN/m<sup>2</sup>).

3. The results of one negative load test may be used when the ultimate load exceeds 60 psf (2.874 kN/m<sup>2</sup>) and the allowable wind uplift load does not exceed 20 psf (0.958 kN/m<sup>2</sup>).

**B4.1.3** Installation of the unit shall comply with published recommendations of the manufacturer. Pertinent data, such as fastener size, type and spacing, and maximum gap between extruded curb and wood framing on curb-mounted

## PROPOSED REVISIONS TO THE ACCEPTANCE CRITERIA FOR PLASTIC GLAZED SKYLIGHTS

units, shall be observed and noted, in the test report, by the testing agency. The method of installing the test specimens will establish the installation method recognized in the evaluation report. Operable skylights shall be tested in the closed and latched position.

**B4.1.4** Inner dome(s) and/or flat lights shall be removed before testing. In lieu of this, holes of sufficient size and quantity shall be drilled in all but the outer dome, enabling the pressure on each side of each inner dome or flat light to be equalized. The holes shall be located in a manner such that the strength of each inner dome or flat light is not affected. The test pressure shall be measured across the outer dome.

**B4.1.5** Test equipment for superimposed loading shall be adequate to develop anticipated ultimate loads. If loading is not carried to failure, the highest value achieved will be considered the ultimate value.

**B4.1.6** For skylights under positive uniform loading, deflection measuring devices shall be located at critical points, in order that adequate measurements can be made to evaluate performance.

**B4.1.6.1** For domed skylights, measurements shall be perpendicular to the tangent of the original surface. For "free-blown" units, measuring devices must be located at the highest point and at points located half way up the dome from the midpoint of each side. For "pyramids," measuring devices shall be located at the uppermost point and at points halfway down each rib.

**B4.1.6.2** For flat skylights, measurements shall be made at the center of the skylight and at the midpoint of each side. The deflection gauges shall be installed so that the deflection of the plastic glazing material can be measured without being influenced by possible movement of, or movement within, the test unit or supporting members.

For each test unit, deformation due to positive loads shall be recorded at each load increment, to develop a comprehensive curve indicating the load which produces a deflection of  $L/20$  when measured normal to the shortest span involved. Exceptions to this requirement shall be discussed with the ICC-ES staff prior to testing.

**B4.1.7** For domed skylights, ultimate load is defined as the load causing plastic cracking, crazing, creasing, strain marring; excessive or permanent deflection; or disengagement of the dome unit.

**B4.1.8** For flat skylights, failure at ultimate load is defined as plastic cracking, crazing, creasing, strain marring, permanent deflection, or disengagement of the unit.

**B4.1.9** For recognition of positive allowable loads of 20 psf to 35 psf ( $0.96 \text{ kN/m}^2$  to  $1.68 \text{ kN/m}^2$ ) [60 to 105 psf ( $2.87$  to  $5.03 \text{ kN/m}^2$ ) ultimate loads, respectively]:

The allowable load is the lesser of the average ultimate load divided by a safety factor of 3.0, the load causing a framing or curb member deflection of  $L/180$  where "L" is the curb length, or the load that causes a flat plastic skylight deflection of  $L/20$  of the shortest span.

The ultimate positive load for each size and type of unit

shall be determined and the tests conducted in accordance with the following:

**B4.1.9.1** Prior to testing, units shall be stabilized to the testing environment in accordance with Procedure A, ASTM D 618.

**B4.1.9.2** Uniform loads shall be applied by differential air pressure exerted with a vacuum or pressure pump.

**B4.1.9.3** Positive load testing shall comply with Procedure A of ASTM E 330, when modified as follows:

**B4.1.9.3.1** Seventy-five percent of the allowable load is applied and held for one minute. The pressure is then released and initial readings are recorded after a recovery period of not more than five minutes at zero load.

**B4.1.9.3.2** The allowable load is applied and held for one minute. Pertinent deflection readings and visual observations are then recorded.

**B4.1.9.3.3** Positive loading is then continued, in 5 psf ( $0.24 \text{ kN/m}^2$ ) increments, up to the ultimate uniform load. At each load increment, the load is held for one minute, and pertinent deflection readings and visual observations are recorded. Pressures are not released prior to increasing pressure to the next incremental load.

**B4.1.10** As an alternate to Section B4.1.9, for recognition of domed units for positive allowable loads of 20 psf to 35 psf ( $0.96 \text{ kN/m}^2$  to  $1.68 \text{ kN/m}^2$ ), the following is necessary:

**B4.1.10.1** The average ultimate load, as defined in Section B4.1.7, of at least three test specimens shall be at least three times the allowable load, except that the load causing excessive deflection shall exceed 1.5 times the allowable load. Upon release of the ultimate load, the dome shall return, unassisted, to within "D" inch(es) of its original configuration within five minutes of load removal. "D" is equal to 1 percent of the longest side of the unit. Application of loads to the test units must be in accordance with Sections B4.1.9.1 through B4.1.9.3.

**B4.1.10.2** The additional tests on weathered plastics specified in Section B4.2.4 shall be conducted.

**EXCEPTION:** In lieu of conducting the additional tests on weathered plastics, representative skylights which have been installed and exposed to natural weathering for a minimum of five years may be subjected to transverse load tests as described in Section B4.1.10.1. The test specimens shall be representative of the product under consideration, and the location of units shall be approved prior to removal by the testing agency. As an alternate to the natural weathering, the skylights may be weathered by accelerated weathering methods, equivalent to the requirements specified in Section B4.2.2.2.

**B4.1.10.3** For each unit recognized in accordance with Section B4.1.10 of this criteria, one specimen shall be subjected to a positive cyclic load test with the following requirements:

**B4.1.10.3.1** Uniform loads shall be applied by differential air pressure exerted on the unit as noted in Section B4.1.9.2.

**B4.1.10.3.2** Seventy-five percent of the allowable load is applied and held for one minute. Upon release of pressure, initial readings are recorded after a recovery period of not more than five minutes at zero load.

## PROPOSED REVISIONS TO THE ACCEPTANCE CRITERIA FOR PLASTIC GLAZED SKYLIGHTS

**B4.1.10.3.3** Full test load (test load = allowable load  $\times$  1.5) is applied and maintained for one minute, while visual observations are recorded. Pertinent deflection readings are taken prior to increasing positive loading to the ultimate uniform load (ultimate uniform load = allowable load  $\times$  3.0). The ultimate uniform load is maintained for one minute, while visual observations are made and deflections recorded.

**B4.1.10.3.4** Pressure is reduced to zero. The dome shall return, unassisted, to within "D" inch(es) (mm) of its unloaded configuration. (For explanation of "D" dimension, see Section B4.1.10.1.) After a recovery period of not more than five minutes, the test is repeated for a minimum of 25 cycles.

**B4.1.10.3.5** Failure due to cyclic loading is defined as plastic cracking, crazing, creasing, strain marring; or disengagement or permanent deflection. In addition, excessive deflection of the plastic dome shall not occur at a positive load equal to or less than 1.5 times the allowable load.

**B4.1.11** For recognition of positive allowable loads greater than 35 psf (1.68 kN/m<sup>2</sup>) [105 psf (5.03 kN/m<sup>2</sup>) ultimate load], additional data will be required that addresses long-term loading and the effects of weathering.

**B4.1.12 Negative Wind Loads:** Except as permitted under Exception 3 of Section B4.1.2, the allowable wind uplift pressure to be recognized shall be substantiated by calculations which derive the negative wind pressure by using a minimum factor of safety of 2 applied to the results of negative uniform load tests. The fasteners attaching the unit to the roof shall be justified in accordance with Section B3.2 of this criteria. The negative uniform load tests shall be conducted in accordance with the following:

**B4.1.12.1** Prior to testing, units shall be stabilized as specified in Section B4.1.9.1.

**B4.1.12.2** Application of uniform loads shall be by differential air pressure exerted by a vacuum or pressure pump.

**B4.1.12.3** The allowable load is applied and held for one minute.

**B4.1.12.4** Loads are increased in 5 psf (0.24 kN/m<sup>2</sup>) increments up to the ultimate uniform negative load (ultimate uniform negative load = allowable load  $\times$  2.0). Load at each increment shall be held for one minute. Pressures are not released prior to application of the next load increment.

### **B4.2 Weathering (Outdoor and Weatherometer) and Strength Tests:**

**B4.2.1** The tests, procedures and standards described in Section B4.2 are applicable to the exterior light-transmitting plastic glazing materials of all skylights. Tests shall be conducted in accordance with either Section B4.2.2 or Section B4.2.3. Dome skylights recognized in accordance with Section B4.1.10 shall also be tested in accordance with Section B4.2.4.

**B4.2.2** Testing under this section (B4.2.2) is applicable to any plastic glazing materials.

**B4.2.2.1** For each plastic material, Type I tensile specimens are cut from the plastic material and tested in accordance with ASTM D 638. For materials that are nonisotropic (physical properties in the machine direction

that are different from the physical properties in the cross-machine direction), there should be a total of 20 specimens: five specimens for each direction for the control specimens, and five specimens for each direction for the weathered specimens. For materials that are isotropic (consistent physical properties in both directions), there need be only 10 total specimens. Five of the specimens shall be used as control and the remaining five specimens are to be exposed to the exposure testing of Section B4.2.2.2 prior to tension testing. Either the tested materials shall have the thickness intended for end use, or the tests can be conducted on the thinnest and thickest material thicknesses of the range of thicknesses intended for end use.

**B4.2.2.2** The exposure specimens are to be tested in accordance with ASTM D 2565, utilizing cycle No. 2. Exposure duration shall be 3000 hours.

As an alternative, the exposure specimens may be exposed for five years in southern Florida at a 45-degree, south-facing exposure.

**B4.2.2.3** Control and weathered specimens shall be examined under 5 $\times$  magnification. Surface changes such as chalking, cracking, checking, crazing, or erosion, or other characteristics that might affect performance of the plastic, are unacceptable.

**B4.2.2.4** The tensile properties of the exposed and control specimens shall be determined in accordance with ASTM D 638.

**B4.2.2.5** For acceptance, the average tensile strength and modulus of elasticity of the exposed specimens shall not be less than 90 percent of the average values of the control specimens. Tensile strength is defined under this criteria as either the tensile strength at yield (for materials that exhibit a distinct yield point, i.e., ductile materials) or as the tensile strength at break (for materials with no distinct yield point, i.e., non-ductile materials).

**B4.2.3** Testing under this section (B4.2.3) is limited to those plastic glazing materials that break upon impact in the Charpy Test and to those plastic glazing materials that have completed testing before July 2002.

**B4.2.3.1** Two 3-inch-by-9-inch (76 mm by 229 mm) panels are required for each thickness of plastic material. One panel shall be treated as control.

**B4.2.3.2** For each thickness of plastic material, one panel shall be subjected to accelerated weathering tests for 2,000 hours in accordance with ASTM G 153. The operating cycle shall be Cycle 1 set forth in Table X1.1 of ASTM G 153.

As an alternate to the 2,000-hour carbon-arc weathering, the xenon-arc weathering requirements specified in Section 24.211.3.3 of UBC Standard 24-2 may be used; or the plastic material may either be exposed to 36,805 Langley's of ultraviolet irradiance at an angle 90 degrees from the horizontal in accordance with Procedure B of ASTM E 838, or exposed for five years in southern Florida, with a southern exposure, at a 45-degree angle.

**B4.2.3.3** Control and weathered plastic specimens shall be examined under 5 $\times$  magnification. Surface changes such as chalking, cracking, checking, crazing, or erosion, or other characteristics that might affect performance of the plastic, will be unacceptable.

## PROPOSED REVISIONS TO THE ACCEPTANCE CRITERIA FOR PLASTIC GLAZED SKYLIGHTS

**B4.2.3.4** Five 1/2-inch-by-5-inch (12.7 mm by 127 mm) specimens shall be cut from both the control and weathered samples, with all specimens evaluated as described in Method B, "Single Beam (Charpy-Type) Test" of ASTM D 256, "Test for Impact Resistance of Plastic and Electrical Insulating Materials." Specimens shall be unnotched and tested at a span of 4 inches (102 mm). The weathered specimens shall have their exposed surface in tension.

**Note:** The Charpy Test is used solely as a means of assessing retention of mechanical properties of the plastic after weathering. It should not be considered to have any significance as a measure of the impact resistance of the product tested.

**B4.2.3.5** For acceptance, maximum loss of impact strength after weathering shall not be greater than 25 percent.

**B4.2.4** The following additional tests are required for dome skylights recognized in accordance with Section B4.1.10:

**B4.2.4.1** Twenty representative samples of each plastic thickness shall be used, of which ten shall be held as controls and the remainder shall be weathered in accordance with Section B4.2.2.2.

**B4.2.4.2** The control and weathered plastic specimens shall be inspected under a 5× magnification, and any cracking or deleterious effects noted. Surface changes such as chalking, cracking, checking, crazing, erosion or other characteristics that might affect performance of the plastic are unacceptable.

**B4.2.4.3 Mandrel Bend Test:** One half of the control and weathered specimens shall be bent at an angle of rotation around a mandrel having a radius no larger than the minimum bend radius and the same angle of rotation of the plastic that occurs when the dome inverts in the full-scale positive load tests. Each small-scale specimen shall be bent around the mandrel a minimum of 25 times and held in the bent position for at least 1 minute. Cracking, crazing, strain marring or other characteristics that might affect performance of the weathered plastic are unacceptable.

**B4.2.4.4** Comparative tensile and elongation tests shall be conducted in accordance with ASTM D 638 on the control and weathered specimens, following the mandrel bend test. Weathered specimens, subjected to the mandrel bend tests, shall have no loss in average tensile strength and a maximum elongation reduction of 20 percent.

**B4.2.4.5** Comparative flexural bending tests shall be conducted in accordance with ASTM D 790 on the control and weathered specimens. Weathered specimens shall have no loss in average flexural strength or calculated modulus of elasticity.

### **B4.3 Smoke-density, Self-ignition Temperature and Flame-spread Classification Tests:**

**B4.3.1 General:** The plastic material shall be an approved plastic complying with UBC Section 217, for use under the UBC, or BNBC Section 2604 for use under the BNBC. The requirements may be satisfied by utilizing a plastic recognized in a current ICC-ES report, or by submitting reports of tests as noted elsewhere in Section B4.3. Recognition is limited to the maximum thickness and density tested.

**B4.3.2 Smoke-density Test:** The maximum smoke-density rating shall not exceed 450, when tested in accordance with UBC Standard 8-1, for use under the UBC, or ASTM E 84 for use under the BNBC; or shall not be greater than 75, when tested in accordance with UBC Standard 26-5, for use under the UBC, or ASTM D 2843 for use under the SBC and BNBC. In both test procedures, samples shall be tested at the maximum thickness and density intended for use.

**B4.3.3 Self-ignition Temperature Test:** Plastic material shall have a self-ignition temperature of 650°F (343°C) or greater when tested in accordance with UBC Standard 26-6, for use under the UBC, or ASTM D 1929 for use under the SBC and BNBC.

**B4.3.4 Burn Rate/Extent Classification Test:** Plastic material shall be classified as either CC1 or CC2 when tested in accordance with UBC Standard 26-7, for use under the UBC, or ASTM D 635 for use under the SBC and BNBC.

### **B4.4 Class B Burning-brand Test Required by Section B3.5.1 or B3.5.2:**

**B4.4.1** Skylights manufactured in a flat or corrugated configuration mounted at a slope less than 4:12 (33<sup>1</sup>/<sub>3</sub>%), or in a dome-shaped configuration with a rise above the mounting flange less than the dome rise requirements of UBC Section 2603.7.1 (Item 2), BNBC Section 2608.3 or SBC Section 2604.6.3, shall pass the Class B burning-brand test in accordance with UBC Standard 15-2 for use under the UBC, or ASTM E 108 or UL 790 for use under the SBC or ASTM E 108 for use under the BNBC. The Class B brand is ignited as required by UBC Standard Section 15.202.4.3, ASTM E 108 or UL 790, as applicable. This test is to be performed on the largest size unit in each profile and material thickness.

**B4.4.2** A Class B brand is placed on the surface of the plastic material at the location considered the most vulnerable. Each brand is secured to the specimen by No. 18, B. & S. gage soft wire. The second brand is applied after all burning resulting from the first brand has ceased.

**B4.4.3** Wind must be directed on the brand at the most critical direction, as determined by the testing agency.

**B4.4.4** Each test is continued either until the brand is consumed and all evidence of flame, glow and smoke has disappeared from both the exposed surface of the material being tested and the underside of the test deck, or until failure occurs. The results of tests in which the brands do not show progressive and substantially complete consumption after application to the unit are to be disregarded.

**B4.5 Class B Burning-brand Test Required by Section B3.5.3:** The following are necessary for Class B burning-brand tests required by Section B3.5.3:

**B4.5.1** Skylights with plastic lights or domes not protected by metal or other noncombustible material shall be subjected to a burning-brand test procedure, shown in Figure 1.

**B4.5.2** The Class B burning-brand is ignited as required by UBC Standard Section 15.202.4.3, ASTM E 108 or UL 790, as applicable.

**B4.5.3** The burning-brand shall self-extinguish without transferring the fire to the dome.

**B4.6 Water-resistance Test:** The following are required for

## PROPOSED REVISIONS TO THE ACCEPTANCE CRITERIA FOR PLASTIC GLAZED SKYLIGHTS

the water-resistance test:

**B4.6.1** One water-resistance test is conducted on the largest unit in each profile and dome shape.

**B4.6.2** Installation of the test specimen shall comply with published recommendations of the manufacturer, and shall be representative of actual installation.

**B4.6.3** The test unit shall be installed at the lowest slope for which recognition is sought.**B4.6.4** The water-resistance test shall comply with ASTM E 331 using the standard pressure differential of 2.86 lbf per square foot (0.137 kN/m<sup>2</sup>) with a test duration of 15 minutes.

**B4.6.5** The condition of acceptance is that there shall be no water leakage on the interior side of the unit.

### **B5.0 TEST REPORTS AND COMMENTS**

**B5.1** Reports of load tests shall include the following information:

**B5.1.1** Dates of the test and the report.

**B5.1.2** Description of test sample (manufacturer's name and address, source of supply, dimensions, model types, material specifications, labeling and other pertinent information).

A qualified representative of the testing laboratory shall witness the installation of the test units.

**B5.1.3** Detailed drawings of the unit, showing dimensioned section profiles, installation and spacing of anchorage, material specifications for retaining frame and curb, and any other pertinent construction details. Any modification of units to obtain reported values shall be noted on drawings.

**B5.1.4** Tabulation of test load increments.

**B5.1.5** Duration of test loads.

**B5.1.6** Written account of observations during and after tests, including the visual observation of each load increment; loads that produce inversion of the dome to or beyond the horizontal plane of the exterior face of the support frame; and permanent deformation at locations

specified for each unit tested.

**B5.1.7** Mode of failure for each unit.

**B5.1.8** Statement from the testing agency indicating that tests were conducted in accordance with this criteria, or a full description of any deviations therefrom.

**B5.1.9** Pressures imposed on each test specimen, and identification of each specimen, particularly with respect to distinguishing features or differences from companion specimens. A separate drawing for each unit will not be required if differences are noted on the drawings provided.

**B5.1.10** Extrapolation of test data is prohibited.

**B5.2** Reports of tests on smoke density, self-ignition temperature and flame-spread shall address items noted in the applicable test standard.

**B5.3** Test reports on Class B burning-brand tests shall address items noted in UBC Standard 15-2, ASTM E 108 or UL 790, as applicable.

**B5.4** Reports of weatherometer tests shall address items noted in Section B4.2.2 or B4.2.3.

**B5.5** Reports of water-resistance tests shall address items noted in Sections B5.1.1 through B5.1.3 and B5.1.6 through B5.1.10, of this criteria. Additionally, the following items shall be provided:

**B5.5.1** Water-application rates.

**B5.5.2** Record of all points of water penetration on the interior face of the test specimens.

**B5.5.3** Statement from the testing laboratory indicating success or failure of the test specimen.

### **B6.0 QUALITY CONTROL**

**B6.1** A quality control manual complying with the ICC-ES Acceptance Criteria for Quality Control Manuals (AC10) shall be submitted.

**B6.2** Third-party follow-up inspections are not required under Part B of this acceptance criteria. ■

PROPOSED REVISIONS TO THE ACCEPTANCE CRITERIA FOR PLASTIC GLAZED SKYLIGHTS

TABLE B1—CROSS REFERENCE OF EDITIONS OF STANDARDS

STANDARD	1997 UBC	1999 BNBC	1999 SBC
ASTM D 256	-93a	-93a	-93a
ASTM D 618	-61 (1981)	-61 (1981)	-61 (1981)
ASTM D 635	UBC Standard 26-7	-97	-88
ASTM D 638	-01	-01	-01
ASTM D 790	-86	-86	-86
ASTM D 1929	UBC Standard 26-6	-96	-77 (1985)
ASTM D 2565	-99	-99	-99
ASTM D 2843	UBC Standard 26-5	-93	-88
ASTM E 84	UBC Standard 8-1	-98 <sup>1</sup>	-95
ASTM E 108	UBC Standard 15-2	-96	-95
ASTM E 330	-84	-97	-84
ASTM E 331	-86	-93	-93
ASTM E 838	Discontinued 1992	—	—
ASTM G 153	-00a	—	—
UL 790	UBC Standard 15-2	-98 <sup>1</sup>	-97

<sup>1</sup>UL790 does not apply under the 1999 BNBC.

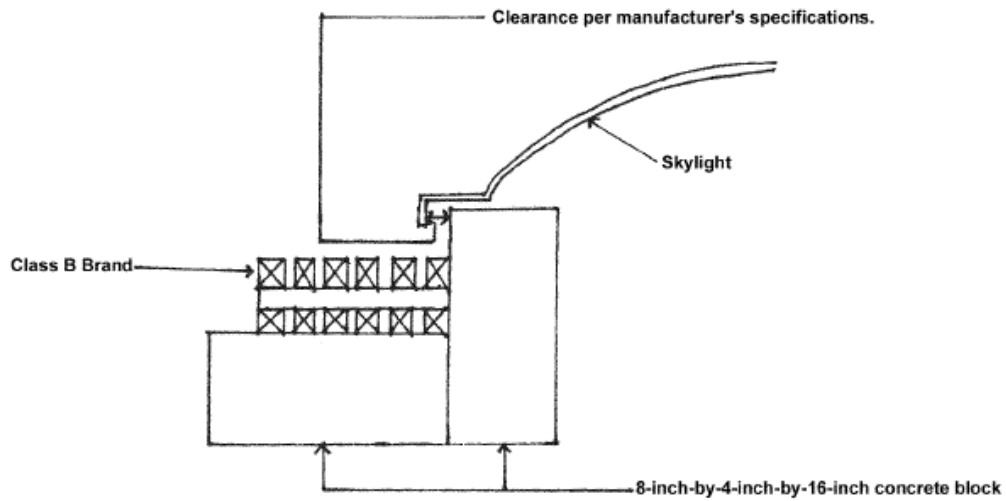

Brand shall be installed against the concrete block.

For SI: 1 inch = 25.4 mm, 1 foot = 304.8 mm.

FIGURE 1