



ICC Evaluation Service, Inc.  
Birmingham Regional Office  
900 Montclair Road, Suite A  
Birmingham, AL 35213  
tel: 205.599.9800  
fax: 205.599.9850  
www.icc-es.org

March 10, 2010

**TO: PARTIES INTERESTED IN EVALUATION REPORTS ON ADHESIVE ANCHORS IN MASONRY ELEMENTS**

**SUBJECT: Revisions to the Acceptance Criteria for Adhesive Anchors in Masonry Elements Subject: AC58-1209-R1, (ME/BG)**

Dear Madam or Sir:

In December 2009, proposed revisions to the subject acceptance criteria were posted on the ICC-ES web site for public comment, under the alternative criteria process. The revised criteria was concurrently balloted to the ICC-ES Evaluation Committee, which approved the revisions with an effective date of January 1, 2010.

A copy of the revised acceptance criteria is enclosed. Evaluation reports issued on or after the effective date noted above, and falling within the scope of this criteria, will be required to comply with the enclosed edition of the criteria. Evaluation reports issued prior to the effective date may be in compliance either with the enclosed criteria or with the previous edition. Evaluation reports based on a superseded version of an acceptance criteria must be brought into compliance with the most recent edition at the time the reports are reissued. Therefore, affected report holders should submit data verifying compliance at the time they apply for re-examination.

If you have any questions, please contact Brian Gerber at (800) 423-6587, extension 3260. You may also reach us by e-mail at [es@icc-es.org](mailto:es@icc-es.org).

Yours very truly,

A handwritten signature in black ink that reads 'Gary G. Nichols'.

Gary G. Nichols, P.E., SECB  
Vice President

ME/BG/GN/md:raf

Enclosure

cc: Evaluation Committee

## ACCEPTANCE CRITERIA FOR ADHESIVE ANCHORS IN MASONRY ELEMENTS

AC58

Approved December 2009

Effective January 1, 2010

Previously approved December 2006, June 2005, February 2005,  
November 2001, January 2001, July 2000, January 1999, January 1998,  
September 1997, April 1995, January 1995

### PREFACE

Evaluation reports issued by ICC Evaluation Service, Inc. (ICC-ES), are based upon performance features of the International family of codes and other widely adopted code families, including the Uniform Codes, the BOCA National Codes, and the SBCCI Standard Codes. Section 104.11 of the *International Building Code*® reads as follows:

The provisions of this code are not intended to prevent the installation of any materials or to prohibit any design or method of construction not specifically prescribed by this code, provided that any such alternative has been approved. An alternative material, design or method of construction shall be approved where the building official finds that the proposed design is satisfactory and complies with the intent of the provisions of this code, and that the material, method or work offered is, for the purpose intended, at least the equivalent of that prescribed in this code in quality, strength, effectiveness, fire resistance, durability and safety.

Similar provisions are contained in the Uniform Codes, the National Codes, and the Standard Codes.

This acceptance criteria has been issued to provide all interested parties with guidelines for demonstrating compliance with performance features of the applicable code(s) referenced in the acceptance criteria. The criteria was developed and adopted following public hearings conducted by the ICC-ES Evaluation Committee, and is effective on the date shown above. All reports issued or reissued on or after the effective date must comply with this criteria, while reports issued prior to this date may be in compliance with this criteria or with the previous edition. If the criteria is an updated version from the previous edition, a solid vertical line (|) in the margin within the criteria indicates a technical change, addition, or deletion from the previous edition. A deletion indicator (→) is provided in the margin where a paragraph has been deleted if the deletion involved a technical change. This criteria may be further revised as the need dictates.

ICC-ES may consider alternate criteria, provided the report applicant submits valid data demonstrating that the alternate criteria are at least equivalent to the criteria set forth in this document, and otherwise demonstrate compliance with the performance features of the codes. Notwithstanding that a product, material, or type or method of construction meets the requirements of the criteria set forth in this document, or that it can be demonstrated that valid alternate criteria are equivalent to the criteria in this document and otherwise demonstrate compliance with the performance features of the codes, ICC-ES retains the right to refuse to issue or renew an evaluation report, if the product, material, or type or method of construction is such that either unusual care with its installation or use must be exercised for satisfactory performance, or if malfunctioning is apt to cause unreasonable property damage or personal injury or sickness relative to the benefits to be achieved by the use of the product, material, or type or method of construction.

*Acceptance criteria are developed for use solely by ICC-ES for purpose of issuing ICC-ES evaluation reports.*

# ACCEPTANCE CRITERIA FOR ADHESIVE ANCHORS IN MASONRY ELEMENTS (AC58)

## 1.0 INTRODUCTION

**1.1 Purpose:** The purpose of this acceptance criteria is to establish requirements for adhesive anchors in masonry elements to be recognized in an ICC-Evaluation Service, Inc. (ICC-ES), evaluation report under the 2009 and 2006 *International Building Code*® (IBC), the 2009 and 2006 *International Residential Code*® (IRC) and the 1997 *Uniform Building Code*™ (UBC). Bases of recognition are IBC Section 104.11, IRC Section R104.11 and UBC Section 104.2.8. The reason for the development of this criteria is to provide guidelines for the evaluation of alternative fasteners to those addressed by the code.

**1.2 Scope:** Anchors recognized under this criteria are limited to allowable stress design applications and uncracked masonry as an alternative to Section 1911 of IBC and Section 2.1.4 of TMS 402/ACI 530/ASCE 5 as referenced in Section 2107.1 of the IBC, Section R301.1.3 of the IRC or Sections 1923.1 and 2107.1.5 of the UBC.

**1.3 Codes and Referenced Standards:** Where standards are referenced in this criteria, these standards shall be applied consistently with the code (IBC, IRC or UBC) upon which compliance is based. For standards referenced in this criteria and the applicable code, editions of standards applicable to evaluation under the various codes are summarized in Table 8.

**1.3.1** 2009 *International Building Code*® (2009 IBC), International Code Council.

**1.3.2** 2009 *International Residential Code*® (2009 IRC), International Code Council.

**1.3.3** 2006 *International Building Code*® (2006 IBC), International Code Council.

**1.3.4** 2006 *International Residential Code*® (2006 IRC), International Code Council.

**1.3.5** 1997 *Uniform Building Code*™ (UBC).

**1.3.6** TMS 402/ACI 530/ASCE 5, Building Code Requirements for Masonry Structures, American Concrete Institute/Structural Engineering Institute of the American Society of Civil Engineers/The Masonry Society.

**1.3.7** AISC 335, Specification for Structural Steel Buildings—Allowable Stress Design and Plastic Design, American Institute of Steel Construction.

**1.3.8** ASTM A 153, Standard Specification for Zinc Coating (Hot-Dip) on Iron and Steel Hardware, ASTM International.

**1.3.9** ASTM A 490, Standard Specification for Heat-Treated Steel Structural Bolts, 150 ksi Minimum Tensile Strength, ASTM International.

**1.3.10** ASTM B 695, Standard Specification for Coatings of Zinc Mechanically Deposited on Iron and Steel, ASTM International.

**1.3.11** ASTM C 55, Standard Specification for Concrete Brick, ASTM International.

**1.3.12** ASTM C 62, Standard Specification for Building Brick (Solid Masonry Units Made From Clay or Shale), ASTM International.

**1.3.13** ASTM C 90, Standard Specification for Load-bearing Concrete Masonry Units, ASTM International.

**1.3.14** ASTM C 129, Standard Specification for Nonload-bearing Concrete Masonry Units, ASTM International.

**1.3.15** ASTM C 216, Standard Specification for Facing Brick (Solid Masonry Units Made from Clay or Shale), ASTM International.

**1.3.16** ASTM C 270, Standard Specification for Mortar for Unit Masonry, ASTM International.

**1.3.17** ASTM C 476, Standard Specification for Grout for Masonry, ASTM International.

**1.3.18** ASTM C 652, Standard Specification for Hollow Brick (Hollow Masonry Units Made From Clay or Shale), ASTM International.

**1.3.19** ASTM C 1314, Standard Test Method for Compressive Strength of Masonry Prisms, ASTM International.

**1.3.20** ASTM E 119, Standard Test Methods for Fire Tests of Building Construction and Materials, ASTM International.

**1.3.21** ASTM E 447, Standard Test Method for Compressive Strength of Masonry Prisms, ASTM International.

**1.3.22** ASTM E 488, Standard Test Method for Strength of Anchors in Concrete and Masonry, ASTM International.

**1.3.23** ASTM E 1512, Standard Test Methods for Testing Bond Performance of Adhesive-Bonded Anchors, ASTM International.

**1.3.24** Standard Method of Cyclic (Reversed) Load Test for Anchors in Concrete or Grouted Masonry, by the Structural Engineers Association of Southern California (SEAOSC); dated August 1, 1996, revised April 17, 1997.

## 1.4 Definitions:

**1.4.1 Anchor Test Series:** A group of identical anchors tested under identical conditions. Identical conditions are adhesive type, diameter, length, embedment, spacing, edge distance, masonry density/weight, test member thickness and masonry compressive strength.

**1.4.2 Adhesive Anchors (anchor):** A fastener placed in masonry that derives its holding strength from a chemical adhesive compound placed between the wall of the hole and the embedded portion of the anchor.

**1.4.3 Chemical Compound:** Organic compounds, comprised of resin and hardener components that form adhesives and cure when blended together. Examples of chemical compounds can include epoxies, polyurethanes, polyesters, methyl methacrylates and vinyl esters.

## 1.4.4 Edge Distance:

**1.4.4.1 Edge Distance (c):** The measure between the anchor centerline and the free edge of the masonry member.

## ACCEPTANCE CRITERIA FOR ADHESIVE ANCHORS IN MASONRY ELEMENTS (AC58)

**1.4.4.2 Critical Edge Distance ( $c_{cr}$ ):** The least edge distance at which the allowable load capacity of an anchor is applicable without reductions.

**1.4.4.3 Minimum Edge Distance ( $c_{min}$ ):** The least edge distance at which the anchors are tested for recognition.

**1.4.5 Embedment Depth ( $h_v$ ):** Distance from test member surface to installed end of anchor which is measured prior to setting of the anchor.

**1.4.6 New Masonry:** Masonry construction with mortar, grout and masonry units that complies with Section 3.1 of this criteria.

### 1.4.7 Spacing:

**1.4.7.1 Anchor Spacing ( $s$ ):** The measure between anchors, centerline to centerline distance.

**1.4.7.2 Critical Spacing ( $s_{cr}$ ):** The least anchor spacing distance at which the allowable load capacity of an anchor is applicable such that the anchor is not influenced by neighboring anchors.

**1.4.7.3 Minimum Spacing ( $s_{min}$ ):** The least anchor spacing at which the anchors are tested for recognition.

**1.4.8 Test Member:** The masonry prism receiving anchors to be tested.

**1.4.9 Uncracked Masonry:** Where analysis indicates no cracking ( $f_t < f_r$ ) due to service loads or deformations. For masonry,  $f_r$  is defined in TMS 402/ACI 530/ASCE 5 Section 3.1.8.2 (IBC) or UBC Section 2108.2.4.6.

## 2.0 BASIC INFORMATION

**2.1 General:** The following information shall be submitted:

**2.1.1 Product Description:** Anchors shall be described as to:

**2.1.1.1** Generic or trade name.

**2.1.1.2** Manufacturer's catalog number.

**2.1.1.3** Adhesive name.

**2.1.1.4** Adhesive packaging.

**2.1.1.5 Basic Materials:**

**2.1.1.5.1 Steel Anchoring Materials:** The bar, bolt, or threaded rod specifications shall be described. Description shall include protective coatings and compliance with an appropriate national standard including physical properties, i.e., tensile strength and hardness.

**2.1.1.5.2 Adhesive Components:** The description of the packaging system, mixing system, mixing ratios, gel time, setting time, storage information and shelf life.

**2.1.1.6 Material Properties:**

**2.1.1.6.1** The bar, bolt, or rod used in the anchor tests shall be tested for compliance with an appropriate national standard for verification of physical properties.

**2.1.1.6.2** For the adhesive used in the anchor tests, the components shall be tested as to establish a standard fingerprint for comparison on a random basis

with future production during the required quality control inspections. For quality control procedures, refer to Section 5.0 of this criteria. The following tests are performed at  $70^{\circ}\text{F} \pm 5^{\circ}\text{F}$  ( $21.1^{\circ}\text{C} \pm 2.77^{\circ}\text{C}$ ) to establish a fingerprint:

- Infrared Absorption Spectroscopy
- Bond Strength (ASTM E 1512)
- Specific Gravity
- Gel Time

Test methods not described here shall be proposed to and accepted by ICC-ES staff before commencing tests.

A detailed description of the procedures used to perform the infrared scan shall be submitted including the type of scanning method used. For injection-type systems, an initial scan of the individual resin and hardener components shall be performed. For capsule-type systems, a scan shall be performed on the individual resin, hardener and aggregate components. In capsule systems where the hardener is impregnated into the aggregate, the combination of these components shall be scanned.

Other test methods may be used with prior concurrence of ICC-ES staff.

**2.1.2 Installation Instructions:** Manufacturer's published instructions for installation, application, curing and design, including allowable loads, shall be submitted.

**2.1.3 Packaging and Identification:** A description of the method of packaging and field identification of the adhesive components. Identification provisions shall include the manufacturer's name and contact information, product numbers, expiration date and evaluation report number.

**2.2 Testing Laboratories:** Testing laboratories shall comply with Section 2.0 of the ICC-ES Acceptance Criteria for Test Reports (AC85) and Section 4.2 of the ICC-ES Rules of Procedure for Evaluation Reports.

**2.3 Test Reports:** Test reports shall include information specified in AC85, Section 13 of ASTM E 488 or Section 8 of ASTM E 1512, as applicable, along with information required to be reported in Section 4.0 of this criteria and as follows:

**2.3.1** Mode of failure for each test (e.g., masonry cracking, masonry spalling, anchor pullout, anchor shear, ductile steel failure, adhesive or grout fracture, etc.).

**2.3.2** Photographs of test equipment and typical failure.

**2.3.3** Report sealed by an registered design professional.

**2.3.4** Verification of anchor sampling at manufacturer's facilities by the testing laboratory. See Section 2.4 of this criteria.

**2.3.5 Strength of Anchoring Materials:** The test report shall note the strength of bolts, bars or threaded rods that are used in the test program as set forth in Section 2.1.1.6.1 of this criteria.

**2.3.6 Masonry Properties:** The test report shall describe the masonry properties as set forth in Sections 3.1 through 3.2 of this criteria.

## ACCEPTANCE CRITERIA FOR ADHESIVE ANCHORS IN MASONRY ELEMENTS (AC58)

**2.4 Product Sampling:** Sampling of the products for tests under this criteria shall comply with Section 3.1 of AC85.

**2.5 Data Analysis:** The documents containing analysis of data shall be sealed by a registered design professional.

### 3.0 TEST AND PERFORMANCE REQUIREMENTS

#### 3.1 Masonry:

**3.1.1** Masonry test specimens shall be prepared according to Chapter 21 of the IBC or UBC. Strength is determined according to either Table 2105.2.2.1.1 or Table 2105.2.2.1.2 of the IBC or Table 21-D of the UBC, where mortar and grout strength are 110 percent maximum of specified strength. As an alternative, strength is determined using prisms without limitations to unit, mortar and grout strength.

**3.1.2** Masonry units shall comply with the appropriate standard. The testing laboratory shall verify that masonry units comply with these standards:

**3.1.2.1** ASTM C 216, ASTM C 62, or ASTM C 652 (IBC or IRC), or UBC Standard 21-1 (UBC): Building Brick (clay or shale).

**3.1.2.2** ASTM C 55 (IBC or IRC) or UBC Standard 21-3 (UBC): Concrete Building Brick.

**3.1.2.3** ASTM C 90 (IBC or IRC) or UBC Standard 21-4 (UBC): Hollow and Solid Load-bearing Concrete Masonry Units.

**3.1.2.4** ASTM C 129 (IBC or IRC) or UBC Standard 21-5 (UBC): Nonload-bearing Concrete Masonry Units.

**3.1.3** Mortar shall be prepared in accordance with Section 2103 of the IBC or UBC or Section R607 of the IRC and ASTM C 270 (IBC or IRC) or UBC Standard 21-15 (UBC). The testing laboratory shall report the mortar composition, type, proportions and compliance with the standard.

**3.1.4** Grout shall be prepared in accordance with Section 2103 of the IBC or UBC and Section R609 of the IRC and ASTM C 476 (IBC or IRC) or UBC Standard 21-19 (UBC). The testing laboratory shall report grout composition, type, proportions and compressive strength.

**3.1.5** Masonry prisms shall be prepared according to ASTM C 1314 (IBC or IRC) or UBC Standard 21-17 (UBC). These prisms shall be tested according to ASTM C 1314 (IBC or IRC) or UBC Standard 21-17 (UBC) and Section 3.2 of this criteria.

**3.1.6** Reinforcement may only be used to stabilize test members during transportation. Reinforcing elements in masonry test members shall be outside the potential failure region of each test anchor or anchor group. The testing laboratory shall verify location of reinforcing.

#### 3.2 Masonry Strength Determination:

**3.2.1** Test members shall be aged a minimum of 21 days prior to the beginning of anchor tests.

**3.2.2** For masonry where strength is determined according to either the IBC Table 2105.2.2.1.1, or IBC Table 2105.2.2.1.2, or UBC Table 21-D, masonry unit, mortar and grout tests shall be done at 28 days of age.

**3.2.3** For masonry less than 90 days old, two tests of two prisms each, prepared according to Section 3.1, shall be tested at the beginning and ending of testing according to Table 1. The beginning test shall be concurrent with the initiation of anchor testing. The beginning and ending strength results shall be averaged (four prisms total) to establish the strength of the test members during the test period.

**3.2.4** For masonry aged 90 days or more, the prism strength shall be the average of a single test of three prisms determined after at least 90 days and within 30 days of anchor testing.

**3.2.5** Reported masonry strength for any anchor test series shall be determined from the tests in this section within the time limitations of Table 1.

#### 3.3 Allowable Loads:

**3.3.1 Allowable Bond Strength:** The allowable tension and shear bond strengths shall be determined by applying the factors of safety in Table 2 to the average ultimate static test loads. The adjustment for seismic or wind load set forth in Section 6.6.5 of this criteria is permitted according to Section 1605.3 of the IBC and Section 1612.3.2 of the UBC if the seismic tests in Section 4.4.7 are conducted.

When the load test program evaluates the anchor with variations in spacing, edge distance, embedment and slab thickness, allowable loads may need corresponding adjustments. Test load results can be analyzed to develop appropriate load adjustment factors, which are applied to the optimum allowable bond strength. When more than one load adjustment factor shall be applied, the product of the factors is used to determine design loads. Examples are anchors installed at reduced spacings and reduced edge distances.

**3.3.2 Allowable Steel Strength:** The allowable steel strength shall be based on the stresses as listed in Table J3.2 of AISC 360 which is referenced in Section 2205.1 of the IBC or Chapter 22, Division III, of the UBC. For materials not listed in the table, the allowable tensile stress,  $F_t$ , and the allowable shear stress,  $F_v$ , shall be calculated as follows:

$$F_t = 0.33 \times F_u$$

$$F_v = 0.17 \times F_u$$

where:

$$F_u = \text{Minimum specified ultimate tensile strength (psi or Pa).}$$

For reinforcing bars, the allowable steel tensile strength shall be based on 20,000 psi (138 MPa) for Grade 40 or Grade 50 reinforcement or 24,000 psi (165 MPa) for Grade 60 and higher reinforcement, applied to the cross-sectional area of the bar as listed in applicable specification for the reinforcing bars.

**3.3.3 Displacement:** Anchor displacement under load is limited to values in Tables 6 and 7.

**3.3.4 Service Loads:** The allowable service load in tension or shear shall be based on the least of the allowable bond strength, steel strength or displacement load. The allowable bond strength for the adhesive based on Sections 3.3.1 and 3.3.3 shall be tabulated along with the allowable load capacities for various threaded steel

## ACCEPTANCE CRITERIA FOR ADHESIVE ANCHORS IN MASONRY ELEMENTS (AC58)

anchor rod or reinforcing bars as described in Section 3.3.2.

**3.3.5 Combined Loads:** For anchors subjected to combined shear and tension forces, where testing has been performed in accordance with Test Series 15 and the results satisfy Equation 1, then  $n = 5/3$  in Equation 2. If no testing has been performed or Equation 1 is not met, then  $n = 1$  (straight line) in Equation 2.

$$\left(\frac{N_t}{N_u}\right)^{5/3} + \left(\frac{V_t}{V_u}\right)^{5/3} \geq 1 \quad \text{Eq. 1}$$

where:

$N_t$  = Average tension test load from combined loading Test Series 15.

$N_u$  = Average tension ultimate load from Test Series 2.

$V_t$  = Average shear test load from combined loading Test Series 15.

$V_u$  = Average shear ultimate load from Test Series 12.

$$\left(\frac{P_s}{P_t}\right)^n + \left(\frac{V_s}{V_t}\right)^n \leq 1 \quad \text{Eq. 2}$$

where:

$P_s$  = Applied service tension load.

$P_t$  = Service tension load.

$V_s$  = Applied service shear load.

$V_t$  = Service shear load.

**3.3.6 Masonry Test Strength:** The average masonry prism strength test results shall be within 10 percent of the nominal specified strengths.

## 4.0 TEST METHODS AND ANALYSIS

### 4.1 General Requirements:

**4.1.1** Anchors shall be tested in accordance with Table 3.

**4.1.2** The adhesive anchors shall be tested in both tension and shear using a high-strength steel anchor rod that has sufficient strength to develop the bond strength of the material. If the bond strength is not developed, then the ultimate load will be limited by the rod strength.

**4.1.3** Holes for anchor test specimens shall be drilled and cleaned in accordance with manufacturer's published recommendations including diameter and depth. Only tools typically used in field installations are permitted. Brand, model number and size of power tool and drill bit type shall be reported. Compliance with applicable standards shall be reported when appropriate. Drilling mode (e.g. rotation only or hammering with rotation) shall be reported for each base material. All procedures shall be conducted or directly verified by the testing laboratory.

**4.1.4** All test anchors shall be installed perpendicular to the surface of the test member with a 6 degree tolerance, in a manner representative of actual field installations.

**4.1.5** The preparation, mixing, placement, and curing of adhesives shall be observed and noted by the testing laboratory and/or inspection agency. Unless otherwise specified, adhesive materials shall be installed and cured at 70°F ± 5°F (21.1°C ± 2.77°C) for the minimum curing time specified in the manufacturer's published recommendations.

**4.1.6** Installation of anchors shall comply with published recommendations of the manufacturer. Pertinent data such as anchor embedment, depth, drill bit diameter, etc., shall be reported by the testing laboratory.

**4.1.7** When tightening torque is used to attach components to adhesive anchors, anchors shall be installed and tested at full torque or the torque tests described in Section 4.4.8 shall be conducted.

**4.1.8 Embedment:** Anchors shall be tested at the minimum embedment for which recognition is desired. For recognition of variable embedment depths at each diameter, anchors may be tested at minimum, medium and maximum embedment depths. Allowable load values for the untested intermediate depths may then be interpolated from test results.

### 4.2 Tests for Service Conditions:

**4.2.1** Tests for service conditions of anchors installed in masonry are performed to determine anchor performance for use in design data. This testing investigates not only the tension and shear performance, but also the effects of several influencing factors including anchor type, adhesive or grout materials, direction of loading, masonry strength, anchor location including spacing and edge distances, and anchor embedment.

The minimum allowable slab thickness shall be 1.5  $h_v$ , unless other thicknesses are substantiated with acceptable test data.

**4.2.2** To determine service conditions, test series 1 through 21 of Table 3 shall be performed as applicable. Where the series permits testing of certain diameters, other diameters may have characteristics established from these series, provided the diameter to embedment ratio is constant.

**4.2.2.1** Test series 1, 2, 3, and 12 establish the tension and shear performance of single anchors. If performance in only one masonry strength is considered, test series 2 and 3 may be eliminated. If test series 2 and 3 are eliminated, the data obtained will be applicable to higher masonry strengths.

**4.2.2.2** Test series 4, 5, 6, 7, 13 and 14 evaluate the critical edge distance,  $c_{cr}$ , and the minimum edge distance,  $c_{min}$ . Since edge distance is dependent on embedment depth, testing shall be performed to establish the relationship of edge distance to embedment where multiple embedments are to be reported. Where only one edge distance,  $c_{cr}$ , but not  $c_{min}$ , is to be recognized in the report, test series 5, 6, 7 and 14 may be eliminated.

**4.2.2.3** Test series 8 and 9 evaluate the critical spacing,  $s_{cr}$ , and the minimum spacing,  $s_{min}$ , performance of anchors. Where only one spacing,  $s_{cr}$ , but not  $s_{min}$ , is to be recognized in the report, test series 9 may be eliminated.

**4.2.2.4** Recognition will be based on the number and spacing of anchors tested. Groups consist of two to

## ACCEPTANCE CRITERIA FOR ADHESIVE ANCHORS IN MASONRY ELEMENTS (AC58)

four anchors with a spacing of less than 4 times the embedment. Test series 8 is mandatory. Group tests shall be conducted using the same size anchors in tension. All anchors shall be loaded simultaneously by a common fixture to distribute the load as equally as possible. Where only one spacing,  $s_{cr}$ , but not  $s_{min}$ , is to be recognized in the report, test series 11 may be eliminated.

### 4.3 Testing and Equipment:

**4.3.1 Equipment:** Test equipment for pullout and shear loading shall be adequate to impose anticipated ultimate loads and shall comply with the requirements of the section for test equipment of ASTM E 488. If loading is not carried to failure, the highest value achieved will be considered the ultimate load.

**4.3.2 Direction of Loading:** Direction of loading for all tensile testing shall be coaxial with the embedded anchor.

**4.3.3 Equipment Set-up:** Test equipment shall not impose pullout or shear reaction loading on the surface or edge of the masonry within a distance given in Table 2 of ASTM E 488. Equipment used to apply shear load shall be designed to minimize frictional resistance using a surface finish specified in ASTM E 488, Section 6.4.4.

**4.3.4 Displacement Measurement:** Displacements caused by shear and tension loads shall be recorded for each test specimen in a continuous manner. The displacement shall be indicated as a function of load and direction of load application and determined in accordance with Sections 5.5 and 8.6.1 of ASTM E 488. The load-displacement curve for tension shall show no decline or plateau until at least 0.7 times the average ultimate load as determined in Test Series 1 of Table 3.

**4.3.5** Where masonry strength is determined according to Section 3.2.2 of this criteria, anchors shall be tested when the test members are 21 to 35 days of age.

### 4.4 Suitability Requirements:

**4.4.1 General Requirements:** Environmental tests are described in ASTM E 1512, as well as other standards as noted. These tests evaluate the suitability of adhesive and grouted anchors under other conditions of use. Some of these tests are optional as noted in Table 3.

#### 4.4.2 Fire Resistance (optional test):

**4.4.2.1 Procedure:** Anchors intended for fire-resistance rated construction shall be evaluated for load resistance during fire exposure according to Section 7.8 of ASTM E 1512. General guidelines for fire exposure are given in ASTM E 119 or UBC Standard 7-1.

**4.4.2.2 Conditions of Acceptance:** Loads for hourly fire ratings shall established based on test results.

#### 4.4.3 Creep (optional):

**4.4.3.1 Procedure:** Unless otherwise noted, all tests are to be performed in accordance with ASTM E 488 and E 1512. Where differences occur, this criteria shall take precedence over ASTM E 488 and E 1512. The tests shall be conducted in accordance with either Section 7.1.2 of ASTM E 1512 as a restrained test, or in accordance with ASTM E 488 as an unrestrained test, but in either case all test series shall be of the same type. A test series shall consist of a minimum of three,  $1/2$ -inch-diameter (12.7 mm), all-thread rods embedded  $4\frac{1}{2}$  inches (114 mm) into

the masonry. Masonry used in all test series in this section of the criteria shall be composed of the same constituent materials, and the masonry prism strength shall be in accordance with Sections 3.2.2 and 3.3.6 at the time of static load tests and at initiation of creep tests, with a minimum masonry age of in accordance with Section 4.3.5. Anchors shall be installed at  $70^{\circ}\text{F} \pm 5^{\circ}\text{F}$  ( $21.1^{\circ}\text{C} \pm 2.77^{\circ}\text{C}$ ). Anchors shall be cured at  $70^{\circ}\text{F} \pm 5^{\circ}\text{F}$  ( $21.1^{\circ}\text{C} \pm 2.77^{\circ}\text{C}$ ) for  $7 \pm 5$  days prior to test commencement. Deviations in anchor diameter, embedment or masonry prism strength from those specified here shall be approved by ICC-ES prior to testing.

**4.4.3.1.1 Static Tension Test Series at  $70^{\circ}\text{F} \pm 5^{\circ}\text{F}$  ( $21.1^{\circ}\text{C} \pm 2.77^{\circ}\text{C}$ ):** A static tension load test series shall be performed at  $70^{\circ}\text{F} \pm 5^{\circ}\text{F}$  ( $21.1^{\circ}\text{C} \pm 2.77^{\circ}\text{C}$ ) to determine the average ultimate tension load. Results that are less than 85 percent of the average value shall be excluded from the determination of the average ultimate tension load, with the average value re-calculated using the remaining results.

**4.4.3.1.2 Static Tension Test Series at Elevated Temperature:** A static tension load test series shall be performed at a minimum masonry temperature of  $110^{\circ}\text{F} \pm 3^{\circ}\text{F}$  ( $43.33^{\circ}\text{C} \pm 1.67^{\circ}\text{C}$ ) to determine the average displacement at ultimate tension load. The masonry temperature shall be established as noted in Section 4.4.3.1.3 of this criteria. The average displacement shall satisfy limits in Table 4 or 5 of this criteria. Displacement results that are greater than 115 percent of the average value shall be excluded from the determination of the average displacement, with the average value re-calculated using the remaining results.

**4.4.3.1.3 Creep Test Series at Elevated Temperature:** Thermocouples shall be embedded a maximum of  $4\frac{1}{2}$  inches (114 mm) from the surface of the masonry into which the anchors are to be installed. The thermocouples shall be cast-in-place or installed into maximum  $1/2$ -inch-diameter (12.7 mm) holes drilled into cured masonry, with the holes sealed in a manner so as to ensure that temperature readings reflect the masonry temperature. After the anchor curing period, the temperature of the specimens shall be increased until the temperature, as determined from the thermocouples, is stabilized for at least 24 hours at the minimum elevated temperature of  $110^{\circ}\text{F} \pm 3^{\circ}\text{F}$  ( $43.33^{\circ}\text{C} \pm 1.67^{\circ}\text{C}$ ). A preload not exceeding 5 percent of the sustained creep load shall be applied before zeroing displacement readings. Sustained creep load is defined as 40 percent of the average ultimate load determined by Section 4.4.3.1.1 of this criteria. The remainder of the sustained creep load shall then be applied. The initial elastic displacement (additional displacement after the preload) shall be measured within 3 minutes of applying the sustained creep load. The masonry specimen temperature shall be recorded at maximum one-hour intervals. As an alternative, the masonry specimen temperature can be recorded at maximum 24-hour intervals, provided the heat chamber temperature necessary to maintain the required masonry temperature is maintained and is recorded at maximum one-hour intervals. For a smooth displacement-versus-time curve, displacements shall be measured at least hourly for the first six hours, and daily for the duration of the test. If the masonry test temperature falls below the minimum specified temperature (including tolerances) for over 24 hours, the creep test duration shall be extended to

## ACCEPTANCE CRITERIA FOR ADHESIVE ANCHORS IN MASONRY ELEMENTS (AC58)

account for the total period below the minimum specified temperature. Creep tests shall continue for a minimum of 42 days. The total displacement at 600 days, which includes the initial elastic displacement plus the creep displacement, is determined for each specimen by projecting a logarithmic trendline (determined by calculating a least-squares fit through the data points, using the equation  $y = c \cdot \ln x + b$ ), constructed from data from not less than the last 20 days (minimum of 20 data points) of the creep test, forward to 600 days.

**4.4.3.2 Conditions of Acceptance:** The average total displacement at 600 days of the creep test series, described in Section 4.4.3.1.3 of this criteria, shall be less than the average displacement at ultimate load determined from Section 4.4.3.1.2 of this criteria or less than 0.12 inch (3.05 mm), whichever is less.

### 4.4.4 In-service Temperature (required):

**4.4.4.1 Procedure:** Temperature effects are evaluated according to ASTM E 1512, Sections 7.1 and 7.6.

**4.4.4.2 Conditions of Acceptance:** Adjustment factors for service loads are established for each temperature.

### 4.4.5 Dampness (optional):

**4.4.5.1 Procedure:** Dampness effects are evaluated according to ASTM E 1512, Sections 7.1 and 7.7. Without the appropriate tests, the anchor system is limited to installation in dry holes. When only the damp hole test is conducted, the anchors are limited to installation in holes that are permitted to be wet, but standing water shall be removed.

**4.4.5.2 Conditions of Acceptance:** The average of the tension test results of the dampness specimens shall be at least 80 percent of the average of the control specimens, with each dampness specimen test result not varying more than 15 percent from the average of the dampness specimen results. Alternatively, all dampness specimen results shall be at least 80 percent of the average of the control specimens. The anchors in the control specimens shall be installed, cured and tested in the same manner and conditions as the dampness specimens. Masonry used in all tests in this section of the criteria shall be composed of the same constituent materials, and the masonry prism strength shall be in accordance with Sections 3.2.2 and 3.3.6 at the time of static load tests. All conditions are to be the same with regard to anchor installation, adhesive curing conditions, duration of adhesive cure prior to load application, test setup and test conditions.

### 4.4.6 Freezing and Thawing (optional):

**4.4.6.1 Procedure:** Freezing and thawing effects are evaluated according to ASTM E 1512, Sections 7.1 and 7.9. The surface area of the side of the masonry in which the anchors are installed shall be covered (within a minimum 3-inch (76 mm) radius from the center of the test anchor) with the specified  $\frac{1}{2}$ -inch (12.7 mm) depth of water. During the freezing and thawing exposure, a tension load shall be applied that is at least 40 percent of the average ultimate tension value of the control specimens. The anchors in the control specimens shall be installed, cured and tested in the same manner and conditions as the freeze-thaw specimens. Masonry used in

all tests under this section of the criteria shall be composed of the same constituent materials, and the masonry prism strength shall be in accordance with Sections 3.2.2 and 3.3.6 at the time of static load tests. All conditions are to be the same with regard to anchor installation, adhesive curing conditions, duration of adhesive cure prior to load application, test setup and test conditions.

**4.4.6.2 Conditions of Acceptance:** The average of the tension test results of the freeze-thaw specimens shall be at least 80 percent of the average of the control specimens, with each test result of the freeze-thaw specimens not varying more than 15 percent from the average of the freeze-thaw specimen results. Alternately, all freeze-thaw specimen results shall be at least 80 percent of the average of control specimens.

**4.4.7 Seismic Tests (optional):** Under a simulated seismic test program, tests shall be performed to determine the seismic tension and shear capacity of anchors. Either Seismic Method 1 or Seismic Method 2 is required for recognition of anchors for earthquake resistance and use of short-term load adjustment factors for wind load resistance. Seismic Methods 1 and 2 apply to testing in grouted masonry under the IBC, IRC and UBC.

### 4.4.7.1 Seismic Method 1 in Grouted Masonry (IRC or UBC):

**4.4.7.1.1 Procedure:** Test procedures shall conform to the SEAOSC Standard Method, except Sections 1.2, 2.1, 3.1, 3.7 and 3.10 are not applicable under this criteria.

**4.4.7.1.2 Conditions of Acceptance:** The anchor shall demonstrate equivalence to the code-complying anchor for which substitution is proposed, as defined in Section 3.3 of the referenced SEAOSC Standard Method.

### 4.4.7.2 Seismic Method 2 in Grouted Masonry (IBC, IRC or UBC):

**4.4.7.2.1 Procedure:** The anchors shall be subjected to a simulated pulsating sinusoidal seismic cycle, detailed in Figure 1, for tension; and a simulated alternating sinusoidal seismic cycle, detailed in Figure 2, for shear loading. The frequency of the loading shall be within the range of 0.1 to 2 Hz. Each seismic cycle test shall consist of at least five anchors. The  $\frac{1}{2}$ -inch-diameter (12.7 mm) or next-larger size of each anchor type (bar, bolt or rod), and the material type (i.e., carbon, stainless, etc.) to be recognized shall be tested at the shallowest and deepest embedments for which seismic recognition is desired. Where the  $\frac{1}{2}$ -inch (12.7 mm) diameter is unavailable, the size shall be selected in consultation with ICC-ES staff. For shear loading, if the anchors at the shallowest embedment meet the conditions of acceptance, seismic tests at deeper embedments may be omitted, provided the allowable load is limited to values established by the tests at the shallowest embedment.

Anchors shall be installed in accordance with the manufacturer's recommendations. For anchors installed with a tightening torque, anchors are installed at full torque, then the applied torque is reduced to 50 percent of the specified torque before applying the test load cycles, to simulate preload relaxation over time. For anchors installed with "turn of the nut," the installation

## ACCEPTANCE CRITERIA FOR ADHESIVE ANCHORS IN MASONRY ELEMENTS (AC58)

torque is measured at the specified number of turns for all samples. The anchors are then tightened to a torque that represents one-half of the average measured torque. For anchors with no specified tightening torque, the anchors are set finger-tight.

Testing shall be performed in grouted masonry, which shall comply with the strength requirements of Sections 3.1 and 3.2. A test series consisting of five anchors, installed in grouted masonry composed of the same constituent materials as that used for the cyclic test anchors, is used to establish the reference ultimate static load values,  $T_{ref}$  and  $V_{ref}$ , for tension and shear.

After the seismic cycles have been completed, each anchor shall be loaded in tension or shear, as applicable, to ultimate capacity.

**4.4.7.2.2 Tension Procedure:** The maximum tension load,  $N_s$ , shall be 1.5 times the tension value for which recognition is desired. The value for which recognition is desired shall be no larger than 133.33 percent of the allowable static load assigned to anchors installed under the same conditions (conditions such as grouted masonry strength, embedment and anchor diameter). The minimum load value for each load level shall not be greater than five percent of the ultimate static capacity in same-strength masonry. For all tension seismic qualification tests, data recording shall include, at a minimum, the peak values of each load cycle applied to the anchor, together with corresponding anchor displacements in the direction of the load. The load cycle is given in Table 4 and Figure 1.

**4.4.7.2.3 Shear Procedure:** The maximum shear test load,  $V_s$ , shall be 1.5 times the shear value for which recognition is desired. The value for which recognition is desired shall be no larger than 133.33 percent of the allowable static load assigned to anchors installed under the same conditions (conditions such as grouted masonry strength, embedment and anchor diameter). For shear loading, the load-displacement results shall be plotted as hysteretic loops. The load cycle is given in Table 5 and Figure 2. Alternating shear loading may be approximated by the application of two half-sinusoidal load cycles at the desired frequency, connected by a reduced-speed ramped loading, as shown in Figure 3.

### 4.4.7.2.4 Conditions of Acceptance:

1. Each anchor shall withstand the loading cycles without failure.

2. The average load in the tests performed on the anchors after the cyclic testing shall be at least 80 percent of the average ultimate static load,  $T_{ref}$  or  $V_{ref}$ , for anchors installed in the reference grouted masonry.

**Exception:** Where individual ultimate loads differ more than 15 percent from the average of the results, all ultimate loads shall be at least 80 percent of the average ultimate static load,  $T_{ref}$  or  $V_{ref}$ .

3. The maximum displacement during all phases of the seismic tests shall satisfy Equation 3 or Equation 4:

$$\Delta_{ns} \leq \frac{N_s}{T_{ref}} \Delta_{ult} \quad \text{Eq. 3}$$

where:

$T_{ref}$  = Average ultimate tension load based on tests described in Section 4.4.7.2.1.

$\Delta_{ns}$  = Measured maximum displacement during seismic tension test (inch or mm).

$\Delta_{ult}$  = Displacement limitation for ultimate tension and shear loads described in Table 6 or 7 (inch or mm).

$$\Delta_{vs} \leq \frac{2V_s}{V_{ref}} \Delta_{ult} \quad \text{Eq. 4}$$

where:

$V_{ref}$  = Average ultimate shear load based on tests described in Section 4.4.7.2.1.

$\Delta_{vs}$  = Measured maximum displacement during seismic shear test (inch or mm).

### 4.4.8 Torque Tests:

**4.4.8.1** In torque tests, the relation between the applied torque moment and the tension force in the bolt shall be measured. These measurements require a calibrated load cell with a measuring error of less than 3 percent throughout the entire measurement range, and a spherical hinge used as a fixture. Figure 4 of this acceptance criteria provides a schematic. Any rotation of the spherical part of the fixture shall be prevented. Masonry prism strength shall be in accordance with Sections 3.1 and 3.2.

The diameter of the clearance hole in the fixture shall correspond to the minimum values recommended by the adhesive anchor manufacturer. The torque moment,  $T_{inst}$ , specified in the adhesive anchor manufacturer's installation instructions shall be applied with a calibrated torque wrench in increments of approximately 90 degrees.

The prestressing force,  $F_p$ , in the anchor rod shall be measured as a function of the applied torque moment. Each diameter of adhesive anchor shall be tested. The minimum sample size per diameter is five. At the discretion of the testing laboratory or manufacturer, the sample size shall be permitted to be increased.

**4.4.8.2 Evaluation:** The following criteria shall be assessed:

$$F_{p, 95\%} \leq 0.6 N_{u, 5\%} \quad \text{Eq. 5}$$

where:

$F_{p, 95\%} = F_{p,m}(1 + K \cdot COV)$  = 95 percent fractile of prestressing forces,  $F_p$ , measured in the torque tests calculated for a confidence level of 90 percent with the mean prestressing force  $F_{p,m}$ , from the torque tests, the corresponding coefficient of variation,  $COV$ , and the appropriate  $K$ -value from Table 9 of this criteria.

$N_{u, 5\%} = N_{u,m}(1 - K \cdot COV)$  = 5 percent fractile of ultimate loads,  $N_u$ , measured in confined or unconfined pull-out tests at minimum embedment performed in uncracked masonry calculated for a confidence level of 90 percent with a mean pull-out capacity,  $N_{u,m}$ , from the pull-out tests, the corresponding coefficient of variation,  $COV$ , and the appropriate  $K$ -value from Table 9 of this report.

## ACCEPTANCE CRITERIA FOR ADHESIVE ANCHORS IN MASONRY ELEMENTS (AC58)

**4.4.8.3 Calculation:** In lieu of pull-out tests, Equation 5 may be satisfied by calculation of  $N_{u,5\%}$  using Equation 6:

$$F_{p,95\%} = \frac{T_{inst}}{k \times d} \text{ lb [N]} \quad \text{Eq. 6}$$

where:

$k_t$  = Torque factor. The torque factor shall be taken as a lower bound value. For normal threaded rods without lubricants or friction-reducing coatings,  $k_t = 0.2$  may be assumed.

### 5.0 QUALITY CONTROL

**5.1** The adhesive products shall be manufactured under an approved quality control program with inspections by an inspection agency accredited by the International Accreditation Service (IAS) or otherwise acceptable to ICC-ES. The quality program shall demonstrate the adhesive's continued compliance with specifications and fingerprint information noted in Section 2.1 of this criteria.

**5.2** Quality documentation complying with the ICC-ES Acceptance Criteria for Quality Documentation (AC10) shall be submitted.

### 6.0 EVALUATION REPORT RECOGNITION

The evaluation report shall include the following:

**6.1** Basic information required by Section 2.1, including product description, installation procedures, packaging and identification information.

**6.2 Exposure:** When anchors are recognized for exterior exposure or damp environments, evidence of durability shall be established by performing the freezing and thawing tests described in Section 4.4.6. The steel shall be corrosion-resistant, stainless steel or coated (zinc, aluminum, etc.) steel. The zinc coating on threaded rod shall be either hot-dipped in accordance with ASTM A 153 with a Class C or D coating weight, or mechanically deposited in accordance with ASTM B 695 with a Class 65 coating having a minimum thickness of 2.1 mils (0.533 mm). Without freeze-thaw tests, the anchor system is limited to interior use; installation in areas of moderate and negligible exterior weather conditions, as defined by Figure 1 of ASTM C 62 or Figure 21-1-1 of UBC Standard 21-1, is permitted.

**6.3 Treated Wood:** Steel anchoring materials in contact with preservative-treated and fire-retardant-treated wood shall be of zinc-coated steel or stainless steel. The coating weights for zinc-coated steel shall be in accordance with ASTM A 153.

**6.4 Installation Conditions:** Anchors shall be recognized for installation in water-filled or damp holes, provided dampness tests in accordance with Section 4.4.5 of this criteria show compliance with the conditions of acceptance.

**6.5 Special Inspection:** All adhesive anchors shall be installed with special inspection. For the IBC and IRC, special inspection shall conform to Section 1704 of the IBC; for the UBC, special inspection shall be in accordance with Section 1701 of the UBC. For each type of packaging or delivery system, the manufacturer shall

submit inspection procedures to verify proper use of adhesives.

**6.6 Evaluation Report Conditions of Use:** The evaluation report shall include the following as conditions of use:

**6.6.1 Fatigue and Shock Loading:** Since an ICC-ES acceptance criteria for evaluating data to determine the performance of adhesive anchors subjected to fatigue or shock loading is unavailable at this time, the use of these anchors under these conditions is beyond the scope of this report.

**6.6.2 Overhead and Wall Installations:** Adhesive anchors may be used to resist tension and shear forces in overhead or wall installations only if consideration is given to the effects of elevated temperature conditions on anchor performance. Figure \_\_\_\_\_ describes load reduction factors for elevated temperatures. (A note shall be included in this figure to state that these load reduction factors apply to tension and shear.)

**6.6.3 Fire-resistance-rated Construction:** Anchors are not permitted to support fire-resistance-rated construction. Where not otherwise prohibited by the code, anchors are permitted for installation in fire-resistance-rated construction provided that at least one of the following conditions is fulfilled:

- Anchors are used to resist wind or seismic forces only.
- Anchors that support gravity load-bearing structural elements are within a fire-resistance-rated envelope or a fire-resistance-rated membrane, are protected by approved fire-resistance-rated materials, or have been evaluated for resistance to fire exposure in accordance with recognized standards.
- Anchors are used to support nonstructural elements.

**6.6.4 Cracked Masonry:** Since an ICC-ES acceptance criteria for evaluating the performance of adhesive anchors in cracked masonry is unavailable at this time, the use of the anchors is limited to installation in uncracked masonry. Cracking occurs when  $f_t > f_r$  due to service loads or deformations.

#### 6.6.5 Seismic Load:

**6.6.5.1** (This version applies where acceptable test data is supplied under the IBC or the IRC.)

**6.6.5.1.1 Grouted Masonry:** The adhesive anchors described in the evaluation report are capable of resisting seismic and wind loads. When using the basic load combinations in accordance with IBC Section 1605.3.1, allowable loads are not permitted to be increased for seismic or wind loading. When using the alternative basic load combinations in IBC Section 1605.3.2 that include seismic or wind loads, the allowable shear and tension loads for anchors are permitted to be increased by  $33\frac{1}{3}$  percent, or the alternative basic load combinations may be reduced by a factor of 0.75.

**6.6.5.2** (This version applies where acceptable test data is not supplied under the IBC or the IRC.)

Use of the anchors to resist seismic loads is beyond the scope of this report. The allowable loads or

**ACCEPTANCE CRITERIA FOR ADHESIVE ANCHORS IN MASONRY ELEMENTS (AC58)**

load combinations for the adhesive anchors shall not be adjusted for anchors subjected to wind loads.

**6.6.5.3** (This version applies where acceptable test data is supplied under the UBC:)

When using the basic load combinations in accordance with UBC Section 1612.3.1, allowable loads are not permitted to be increased for wind or seismic loading. When using the alternative basic load combinations in UBC Section 1612.3.2 that include wind or seismic loads, the allowable shear and tension loads for anchors are permitted to be increased by  $33\frac{1}{3}$  percent.

**6.6.5.4** (This version applies where acceptable test data is not supplied under the UBC:)

Use of the anchors to resist seismic loads is beyond the scope of this report. The allowable loads or load combinations for the adhesive anchors shall not be adjusted for anchors subjected to wind loads.

**6.7** The safety factors used to develop the allowable bond strength shall be listed in the notes section of the table included in the ICC-ES evaluation report.

**6.8** The minimum allowable slab thickness shall be specified in the evaluation report, and shall be no less than  $1\frac{1}{2} h_v$ , unless other values are substantiated by testing. ■

**TABLE 1—STRENGTH TEST TIME LIMITATIONS**

AGE OF MASONRY AT BEGINNING OF ANCHOR TEST	MAXIMUM TIME BETWEEN STRENGTH TESTS (Test Period)	COMMENTS
Less than 21 days	3 days	Per Section 3.2.1, for special tests only
21 - 35 days	7 days	—
36 - 56 days	14 days	—
57 - 90 days	30 days	—
More than 90 days	—	See Section 3.2.4

**TABLE 2—FACTORS OF SAFETY (FS) FOR ADHESIVE ANCHORS IN MASONRY ELEMENTS**

	SEISMIC LOAD TEST			NO SEISMIC LOAD TEST <sup>1</sup>		
	FS		Adjustment for Seismic or Wind Load Permitted?	FS		Adjustment for Wind Load Permitted?
	UBC	IBC and IRC		UBC	IBC and IRC	
Creep Test	4	5	Yes	4	5	No
No Creep Test (Short-term Load only)	5.332	6.672	Yes	5.333	6.673	No

<sup>1</sup>Anchors are not recognized for resisting seismic loads.

<sup>2</sup>Anchors are recognized for resisting short-term seismic or wind loads only, not other loads.

<sup>3</sup>Anchors are recognized for resisting short-term wind loads only, not other loads.

ACCEPTANCE CRITERIA FOR ADHESIVE ANCHORS IN MASONRY ELEMENTS (AC58)

TABLE 3—TESTING SCHEDULE

TEST SERIES NUMBER	TEST	TEST SERIES MANDATORY OR OPTIONAL	ASTM E 488 SECTION	ICC-ES ACCEPTANCE CRITERIA SECTION	MASONRY COMPRESSIVE STRENGTH <sup>1</sup>					REMARKS <sup>3</sup>
						All Diameters	Small	Medium	Large	
<b>SERVICE CONDITIONS (Direction of loading: axial tension)</b>										
1	Single anchors	M	8.4.1	4.2.2.1	Minimum	5	—	—	—	ASTM E 488 Spacing and Edge Distance Guidelines
2	Single anchors	O	8.4.1	4.2.2.1	Medium	5	—	—	—	
3	Single anchors	O	8.4.1	4.2.2.1	Maximum	5	—	—	—	
4	Single anchors, critical edge distance	M	—	4.2.2.1	Minimum	—	5	5	5	$c = c_{cr}$
5	Single anchors, minimum edge distance	O	—	4.2.2.2	Minimum	—	5	5	5	$c = c_{min}$
6	Single anchors, critical edge distance	O	—	4.2.2.2	Maximum	—	5	5	5	$c = c_{cr}$
7	Single anchors, minimum edge distance	O	—	4.2.2.2	Maximum	—	5	5	5	$c = c_{min}$
8	Group of two anchors, critical spacing $s_{cr}$	M <sup>3</sup>	—	4.2.2.3	Minimum	—	5 (3/8")	—	5 (3/4")	$s = s_{cr}$
9	Group of two anchors, minimum spacing distance	O	—	4.2.2.3, 4.2.2.4	Minimum	—	5 (3/8")	—	5 (3/4")	$s = s_{min}$
10	Group of four anchors, critical spacing $s_{cr}$	O <sup>3</sup>	—	4.2.2.3, 4.2.2.4	Minimum	—	5 (3/8")	—	5 (3/4")	$s = s_{cr}$
11	Group of four anchors, minimum spacing $s_{min}$	O	—	4.2.2.3, 4.2.2.4	Minimum	—	5 (3/8")	—	5 (3/4")	$s = s_{min}$
<b>SERVICE CONDITIONS (Direction of loading: shear)</b>										
12	Single anchors <sup>4</sup>	M	8.4.2	4.2.2.1	Minimum	—	—	5	—	—
13	Single anchors, critical edge distance	O	—	4.2.2.2	Minimum	—	—	5	—	$c = c_{cr}$
14	Single anchors, minimum edge distance	O	—	4.2.2.2	Minimum	—	—	5	—	$c = c_{min}$
<b>SERVICE CONDITIONS (Direction of loading: oblique tension 45 degrees)</b>										
15	Single anchors	O	—	3.4.5	Minimum	3	—	—	—	$c = c_{cr}$
<b>SUITABILITY REQUIREMENTS</b>										
16	Fire resistive	O	—	4.4.2.	Minimum	See Section 7.1, 7.8, ASTM E 1512				—
17	Creep	O	—	4.4.3	Minimum	See Section 7.1, 7.5, ASTM E 1512				—
18	In-Service temperature	M	—	4.4.4	Minimum	See Section 7.1, 7.6, ASTM E 1512				—
19	Dampness	O	—	4.4.5	Minimum	See Section 7.1, 7.7, ASTM E 1512				—
20	Freezing and thawing	O	—	4.4.6	Minimum	See Section 7.1, 7.9, ASTM E 1512				—
21	Seismic	O	—	4.4.7, Table 2	Sec. 4.4.7.2.1	—	—	5	—	—

For SI: 1 inch = 25.4 mm, 1 psi = 6.89 kPa.

<sup>1</sup>Where anchors are evaluated at more than one masonry strength level, certain tests must be repeated at each masonry strength.

<sup>2</sup>s = spacing, c = edge distance.

<sup>3</sup>If Series 10 is conducted then Series 8 is considered an optional test.

<sup>4</sup>Tests for "single anchors, critical edge distance" (No. 13 series) should be tested first. If steel failure occurs, then tests for single anchors (No. 12 series) can be deleted.

**ACCEPTANCE CRITERIA FOR ADHESIVE ANCHORS IN MASONRY ELEMENTS (AC58)**

**TABLE 4—TENSION CYCLIC LOAD PROGRAM**

LOAD LEVEL	NUMBER OF CYCLES
$N_s$	10
$N_i$	30
$N_m$	100

where:

- $N_i$  = A load midway between  $N_s$  and  $N_m$ .
- $N_m$  = One-fourth the average ultimate tension load,  $T_{ref}$ , in masonry of the tested strength.
- $N_s$  = The maximum tension test load.

**TABLE 5—SHEAR CYCLIC LOAD PROGRAM**

LOAD LEVEL	NUMBER OF CYCLES
$\pm V_s$	10
$\pm V_i$	30
$\pm V_m$	100

where:

- $V_i$  = A load midway between  $V_s$  and  $V_m$ .
- $V_m$  = One-fourth the average ultimate shear load,  $V_{ref}$ , in masonry of the tested strength.
- $V_s$  = The maximum shear test load.

**TABLE 6—DISPLACEMENT LIMITATIONS (Imperial)**

ANCHOR DIAMETER (inches)	LIMITATION FOR DETERMINING DESIGN LOADS		LIMITATION FOR DETERMINING ULTIMATE LOADS
	Tension (inch)	Shear (inch)	Tension and Shear <sup>1</sup> (inches)
$\frac{3}{16}$	0.0357	0.0625	0.188
$\frac{1}{4}$	0.0385	0.0625	0.250
$\frac{5}{16}$	0.0417	0.0625	0.313
$\frac{3}{8}$	0.0455	0.0714	0.375
$\frac{1}{2}$	0.0500	0.0714	0.500
$\frac{5}{8}$	0.0556	0.0833	0.625
$\frac{3}{4}$	0.0625	0.0833	0.750
$\frac{7}{8}$	0.0714	0.1000	0.875
1	0.0833	0.1000	1.000
$1\frac{1}{8}$	0.1000	0.1250	1.125
$1\frac{1}{4}$	0.1250	0.1250	1.250
$1\frac{3}{8}$	0.1250	0.1667	1.375
$1\frac{1}{2}$	0.1250	0.1667	1.500

<sup>1</sup>The displacement under shear only applies to the shear deflection equation in Section 4.4.7.2.4, and is not to be used for establishing an ultimate load.

ACCEPTANCE CRITERIA FOR ADHESIVE ANCHORS IN MASONRY ELEMENTS (AC58)

TABLE 7—DISPLACEMENT LIMITATIONS (Metric)

ANCHOR DIAMETER (mm)	LIMITATION FOR DETERMINING DESIGN LOADS		LIMITATION FOR DETERMINING ULTIMATE LOADS
	Tension (mm)	Shear (mm)	Tension and Shear <sup>1</sup> (mm)
M6	1.0	1.6	6
M8	1.1	1.6	8
M10	1.2	1.8	10
M12	1.3	1.8	12
M16	1.4	2.2	16
M20	1.6	2.2	20
M22	1.8	2.6	22
M24	2.2	2.6	24
M30	3.0	3.0	30

<sup>1</sup>The displacement under shear only applies to the shear deflection equation in Section 4.4.7.2.4, and is not to be used for establishing an ultimate load.

TABLE 8—CROSS REFERENCE STANDARD EDITIONS<sup>1,2</sup>

STANDARD	1997 UBC	2006 IBC	2009 IBC	2006 IRC	2009 IRC
ACI 318	1995	2005	2008	2005	2008
TMS 402/ACI 530/ASCE 5	—	2005	2008	2005	2008
AISC 360	1989	2005	2005	2005	2005
ASTM A 490	1983a	2004	2004	2004	2004
ASTM C 55	UBC Standard 21-3	2003	2006	2003	2006
ASTM C 62	UBC Standard 21-1	2004	2005	2004	2005
ASTM C 90	UBC Standard 21-4	2003	2006b	2003	2006b
ASTM C 129	UBC Standard 21-5	—	—	2003	2006
ASTM C 216	UBC Standard 21-1	2004a	2007	2004a	2007
ASTM C 270	UBC Standard 21-15	2004	2007	2004	2007
ASTM C 476	UBC Standard 21-19	2002		2002	—
ASTM C 652	UBC Standard 21-1	2004a	2005a	2004a	2005a
ASTM C 1314	1991	2003b	2007a	—	2007
ASTM E 447	UBC Standard 21-17	—	—	—	—
ASTM E 119	UBC Standard 7-1	2000	2007	2000	2007
ASTM E 488	1996	1996	1996	1996	1996
ASTM E 1512	1993	1993	1993	1993	1993
ASTM A 153	1995	2003	2005	2003	2005
ASTM B 695	1991	2000	2004	2000	2004

<sup>1</sup>Blank entries indicate the standard is not applicable or referenced in the specific code.

<sup>2</sup>For standards referenced in the criteria, editions of standards applicable to various codes are summarized in this table.

ACCEPTANCE CRITERIA FOR ADHESIVE ANCHORS IN MASONRY ELEMENTS (AC58)

TABLE 9—K VALUES FOR EVALUATING THE CHARACTERISTIC CAPACITY AT 90 PERCENT CONFIDENCE

NUMBER OF TESTS	K
4	3.957
5	3.400
6	3.091
7	2.894
8	2.755
9	2.649
10	2.568
15	2.329
20	2.208
25	2.132
30	2.080
40	2.010
50	1.965
—	1.645

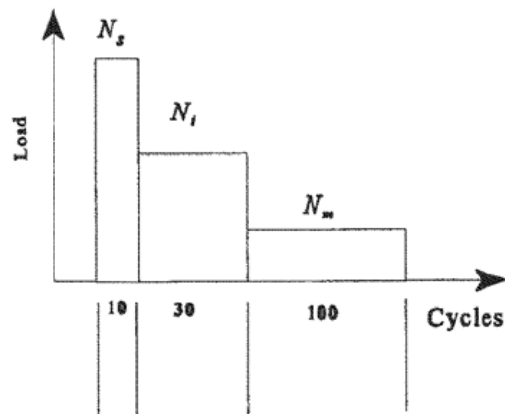

FIGURE 1—SEISMIC TENSION CYCLE

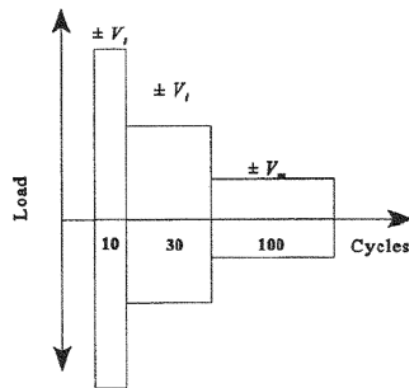

FIGURE 2—SEISMIC SHEAR CYCLE

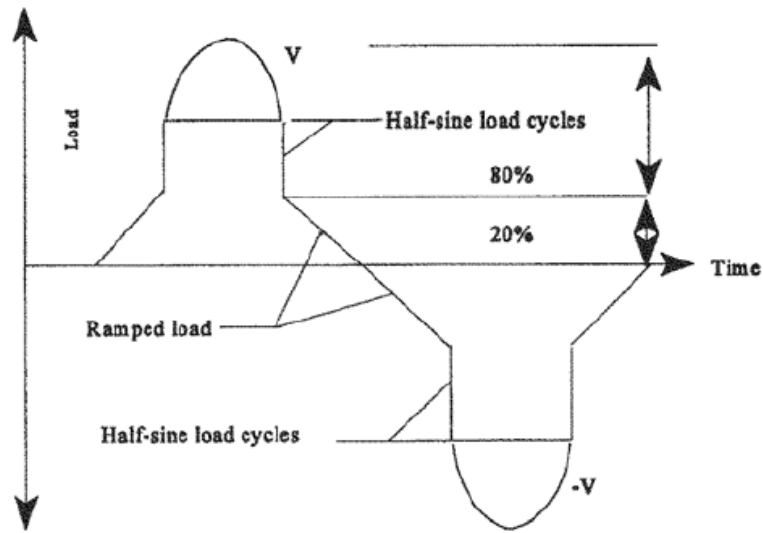

FIGURE 3—APPROXIMATION OF ALTERNATING SHEAR LOADING

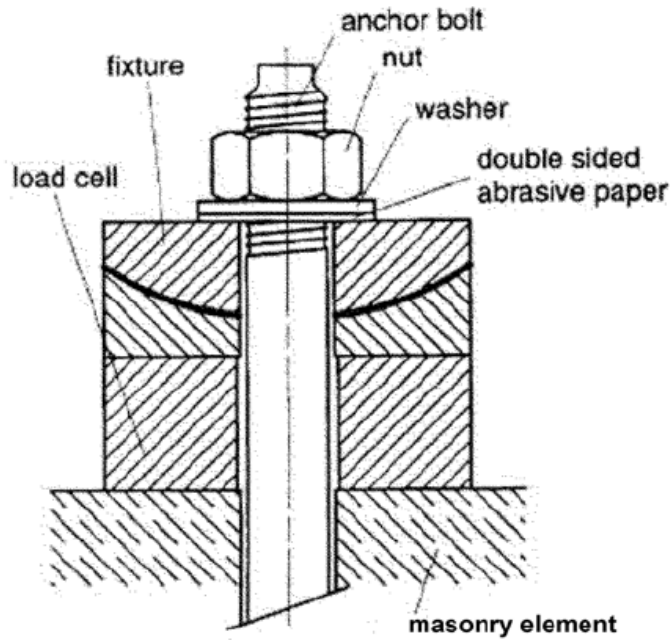

FIGURE 4—TORQUE TEST SCHEMATIC