



ICC Evaluation Service, Inc.
Birmingham Regional Office
900 Montclair Road, Suite A
Birmingham, AL 35213
tel: 205.599.9800
fax: 205.599.9850
www.icc-es.org

May 13, 2010

**TO: PARTIES INTERESTED IN EVALUATION REPORTS ON STEEL DECK
ROOF AND FLOOR SYSTEMS**

**SUBJECT: Proposed Revisions to the Acceptance Criteria for Steel Deck Roof and
Floor Systems, Subject AC43-0610-R2 (DM/WM)**

Hearing Information:

Wednesday, June 16, 2010
8:00 a.m.

DoubleTree Hotel
808 South 20th Street
Birmingham, Alabama 35205
(800) 222-8733

Dear Madam or Sir:

Revisions to the acceptance criteria in questions will be on the agenda of the Evaluation Committee hearing noted above. The criteria proposal is a modification of the proposal which was brought before the committee in February 2010. The modifications to the original proposal address comments received during the public review process and are noted in the enclosed criteria as double underline and double ~~strikeout~~. The following is a list of significant changes:

1. The Tri-Services Manual will remain in AC43 with the following conditions:
 - a. If welding is used on all connections as indicated in the Tri-Services Manual Sections 5-6a(1) thru 5-6a(4) and Sections 5-6a(6) and 5-6a(7), no full-scale testing is required for standard decks as described in Sections 5-6b and 5-6c.
 - b. Fasteners other than welds, welds not covered in the Tri-Services Manual, or a combination of Tri-Services welds and other fasteners require full-scale testing as indicated in Section 5-6a(5) of the Tri-Services Manual.
 - c. Powder-actuated or pneumatically driven fasteners are excluded from use in most seismic zones and categories in Section 5-6a(5) of the Tri-Services Manual. AC43 does not give an exception to this exclusion. If there is an objection to this, ICC-ES requests information to support the removal of the excluded use of these fasteners in seismic zones and categories. Upon receipt of the information, ICC-ES will edit AC43 to modify the Tri-Services Manual to delete this exception. Otherwise, ICC-ES will be required to follow the exception and will limit powder-actuated or pneumatically driven fasteners to Seismic Zone 1 and areas with a

wind velocity of less than 100 mph for the UBC and Seismic Category A and B and 110 mph (3-second gust) for the IBC.

- d. The steel decks will be limited to the thickness and standard shapes as indicated in the Tri-Services Manual.
 - e. Concrete fill decks will require full-scale testing.
2. The Steel Deck Institute's Diaphragm Design Manual, 3th edition (DDM03), will be used as follows:
- a. Fasteners used in side lap connections:
 - i. These fasteners can be generic screws, welds or button punches as described in Chapter 4 of DDM03, without testing to determine the connection strength and stiffness.
 - ii. Other types of fasteners used for side lap connections would require small-scale connection tests as described in AISI-S905.
 - iii. For generic screws listed in DDM03, the evaluation report will report the required screw as meeting the industry standard, ASTM C 1513.
 - b. Fasteners used in support or framing connections:
 - i. These fasteners can be generic screws, welds, or proprietary fasteners; however, different levels of testing are required.
 - ii. Generic screw connection values reported in DDM03, Section 4, can be used in the calculation of diaphragm. These connection values will be reported in the evaluation report as a minimum that has to be met by the screw used in the installation of the diaphragm. The evaluation report will also state that the screws used must have a current evaluation report which supports the connection values required by the diaphragm.
 - iii. If a full-scale test of the diaphragm is required (for other reasons given later), the generic screws used in the full-scale test have to be fingerprinted for connection strength and stiffness and these values reported in the evaluation report as the required screw values, not the generic values listed in DDM03.
 - iv. Proprietary fasteners require testing to AISI S905 to determine the shear strength and stiffness for the fastener in the connection. These values may be used in the calculation of the shear strength and stiffness of the diaphragm. The evaluation report will indicate the proprietary fastener required to be used in the installation of the diaphragm.
3. Section 4.2.3 of AC43 was removed in the 0210-R1 issue. Portions of Section 4.2.3 are being reinstated in this issue 0610-R2. The portions being reinstated are to provide information where AISI-S907 is not clear or is entirely unhelpful.

4. Section 4.2.6 is being removed. The analysis of diaphragm tests will now be in accordance with AISI-S907.
5. There is a conflict between the requirements of the Tri-Services Manual and SDI concerning the minimum cover of concrete over the steel deck. The Tri-Services Manual requires a minimum of 2.5 inches of cover over the steel deck in Section 5-6d. SDI requires a minimum of 2 inches of cover over the steel deck in ANSI/SDI-C1.0, Section 2.4.B.3.a.
6. Add the Standard for Composite Steel Floor Deck, ANSI/SDI C1.0-06.
7. Section 3.3.1.2 has been changed to correct the definition of D_{DL} under item (4). Also, this item gives a condition for the warping constant, but does not say what happens if the condition is not met. This item is being corrected to show what to do if the condition is not met.
8. Section 3.7 was added to address uplift capacity of deck attachments.
9. Evaluation report holders have brought it to our attention that it may be an overly restrictive interpretation of Section 6.4 (and Section 6.5) of AC43 to require a code-complying roof covering over the panels when used as a roof deck, for panels that have not been evaluated for compliance with AC166. The corrosion resistance of the fasteners and ability to seal the hole in the panels due to the fasteners is not a subject of AC43, nor is the corrosion resistance of the steel deck panel. These items are addressed in AC166, (Section 1.2 of AC43 currently directs the user of AC43 to AC166, if the steel deck panel is to be used as a roof covering). In response, the ICC-ES staff is proposing to replace Sections 6.4 and 6.5 with the statement below. The ICC-ES staff solicits comments on this proposed revision:

“6.4 Evaluation reports on steel deck roof systems, for which compliance with AC166 has not been evaluated, shall indicate that use of the steel deck roof systems as roof coverings is outside the scope of the report.”

You are cordially invited to submit written comments on agenda items, or to attend the Evaluation Committee hearing and present verbal comments. If you wish to contribute to the hearing, please note the following:

1. Written comments that are received by the Los Angeles business/regional office by **June 1, 2010**, will be forwarded to the committee prior to the hearing, and will be posted on the ICC-ES web site shortly after the comment deadline.
2. Written comments received up to ten days before the meeting, and staff memos responding to comments, will be posted to the web site on **June 10, 2010**.
3. ICC-ES is no longer providing printed copies at the meeting of proposed acceptance criteria, staff memos or public comments. These documents will be available on a limited number of CDs at the meeting, for uploading to computers; and ICC-ES will make arrangements with the hotel business center to have hard copies available for photocopying.

4. Written comments that miss the deadline noted in item (1), above, will only be available at the meeting if you provide 35 copies, collated, stapled, and three-hole punched, either at the meeting itself or to the Los Angeles business/regional office by **June 10, 2010**.
5. If you plan to speak for more than 15 minutes, or offer a visual presentation lasting longer, you should notify ICC-ES staff as far as possible in advance. There will be a computer, projector, and screen available at the meeting for anyone wishing to make a visual presentation, and presentations in most cases will need to be in PowerPoint format. Also, ICC-ES will need to be provided with your presentation at least a half-hour before the start of the relevant meeting session (morning or afternoon) on either a CD or a flash card.
6. If you have any special needs related to a presentation, you should contact ICC-ES staff well in advance of the meeting.
7. Any visual aids for viewing at committee meetings (charts, overhead transparencies, slides, videos, electronic presentations, etc.) will be permitted only if a copy is provided to ICC-ES, before the presentation, in a medium that can be retained with other records of the meeting.
8. Any materials submitted for committee consideration are considered nonconfidential and available for public discussion, as noted in Section 2.7 of the ICC-ES Rules of Procedure for the Evaluation Committee.
9. Prior to the meeting, you should refrain from trying to communicate directly with committee members about agenda items, either verbally or in writing. Committee members reserve the right to refuse such communications.

Your cooperation with these guidelines is much appreciated, as is your interest in the deliberations of the Evaluation Committee. If you have any question, please contact the undersigned at (800) 423-6587, extension 5681, or Woods McRoy, Senior Staff Engineer, at extension 5686. You may also reach us by e-mail at es@icc-es.org.

Yours very truly,

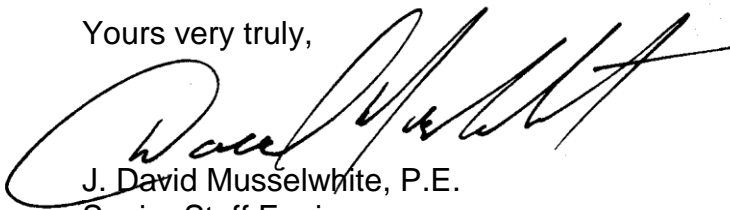

J. David Musselwhite, P.E.
Senior Staff Engineer

DM/raf

Enclosures

cc: Evaluation Committee



ICC EVALUATION SERVICE, INC., RULES OF PROCEDURE FOR THE EVALUATION COMMITTEE

1.0 PURPOSE

The purpose of the Evaluation Committee is to monitor the work of ICC-ES, in issuing evaluation reports; to evaluate and approve acceptance criteria on which evaluation reports may be based; and to sponsor related changes in the applicable codes.

2.0 MEETINGS

2.1 The Evaluation Committee shall schedule meetings that are open to the public in discharging its duties under Section 1, subject to Section 3.

2.2 All scheduled meetings shall be publicly announced.

2.3 Two-thirds ($\frac{2}{3}$) of the voting Evaluation Committee members shall constitute a quorum. A majority vote of members present is required on any action.

2.4 In the absence of the nonvoting chairman-moderator, Evaluation Committee members present shall elect an alternate chairman from the committee for that meeting. The alternate chairman shall be counted as a voting committee member for purposes of maintaining a committee quorum and to cast a tie-breaking vote of the committee.

2.5 Minutes of the meetings shall be kept.

2.6 An electronic audio record of meetings shall be made by ICC-ES; no other audio, video, electronic or stenographic recordings of the meetings will be permitted. Visual aids (including, but not limited to, charts, overhead transparencies, slides, videos, or presentation software) viewed at meetings shall be permitted only if the presenter provides ICC-ES before presentation with a copy of the visual aid in a medium which can be retained by ICC-ES with its record of the meeting and which can also be provided to interested parties requesting a copy. A copy of the ICC-ES recording of the meeting and such visual aids, if any, will be available to interested parties upon written request made to ICC-ES together with a payment as required by ICC-ES to cover costs of preparation and duplication of the copy. These materials will be available beginning five days after the conclusion of the meeting but will no longer be available after one year from the conclusion of the meeting.

2.7 Parties interested in the deliberations of the committee should refrain from communicating, whether in writing or verbally, with committee members regarding agenda items. All written communications and submissions regarding agenda items should be delivered to ICC-ES. All such written communications and submissions shall be considered nonconfidential and available for discussion in open session of an Evaluation Committee meeting, and shall be delivered at least ten days before the scheduled Evaluation Committee meeting if they are to be forwarded to the committee. Materials delivered to ICC-ES at least ten

days before the scheduled meeting will be posted on the ICC-ES web site (www.icc-es.org) prior to the meeting. After this time, parties wishing to submit materials for consideration by the Evaluation Committee must deliver a sufficient number of copies as directed by ICC-ES. Consideration of materials not received by ICC-ES at least ten days before the meeting is at the discretion of the Evaluation Committee. Following the meeting, ICC-ES will make all materials considered by the Evaluation Committee available on the web site for a maximum period of one year following the meeting. The committee reserves the right to refuse recognition of communications which do not comply with the provisions of this section.

3.0 CLOSED SESSIONS

Evaluation Committee meetings shall be open except that the chairman may call for a closed session to seek advice of counsel.

4.0 ACCEPTANCE CRITERIA

4.1 Acceptance criteria are established by the committee to provide a basis for issuing ICC-ES evaluation reports on products and systems under codes referenced in Section 2.0 of the Rules of Procedure for Evaluation Reports. They also clarify conditions of acceptance for products and systems specifically regulated by the codes.

Acceptance criteria may involve a product, material, method of construction, or service. Consideration of any acceptance criteria must be in conjunction with a current and valid application for an ICC-ES evaluation report, an existing ICC-ES evaluation report, or as otherwise determined by the Evaluation Committee.

4.2 Procedure:

4.2.1 Proposed acceptance criteria shall be developed by the ICC-ES staff and discussed in open session with the Evaluation Committee during a scheduled meeting, except as permitted in Section 5.0 of these rules.

4.2.2 Proposed acceptance criteria shall be available to interested parties at least 30 days before discussion at the committee meeting.

4.2.3 The committee shall be informed of all pertinent written communications received by ICC-ES.

4.2.4 Attendees at Evaluation Committee meetings shall have the opportunity to speak on acceptance criteria listed on the meeting agenda, to provide information to committee members.

4.3 Approval of acceptance criteria shall be as specified in Section 2.3 of these rules.

4.4 Actions of the Evaluation Committee may be

ICC EVALUATION SERVICE, INC., RULES OF PROCEDURE FOR THE EVALUATION COMMITTEE

appealed in accordance with the ICC-ES Rules of Procedure for Appeal of Acceptance Criteria or the ICC-ES Rules of Procedure for Appeals of Evaluation Committee Technical Decisions.

5.0 COMMITTEE BALLOTING FOR ACCEPTANCE CRITERIA

5.1 Acceptance criteria may be issued without a public hearing following a 30-day public comment period and a majority vote for approval by the Evaluation Committee when, in the opinion of ICC-ES staff, one or more of the following conditions have been met:

1. The subject is nonstructural, does not involve life safety, and is addressed in nationally recognized standards or generally accepted industry standards.
2. The subject is a revision to an existing acceptance criteria that requires a formal action by the Evaluation Committee, and public comments raised were resolved by staff with commenters fully informed.
3. Other acceptance criteria and/or the code provide precedence for the revised criteria.

5.2 Negative votes must be based upon one or more of the following, for the ballots to be considered valid and require resolution:

- a. *Lack of clarity*: There is insufficient explanation of the scope of the acceptance criteria or insufficient description of the intended use of the product or system; or the acceptance criteria is so unclear as to be unacceptable. (The areas where greater clarity is required must be specifically identified.)
- b. *Insufficiency*: The criteria is insufficient for proper evaluation of the product or system. (The provisions of the criteria that are in question must be specifically identified.)
- c. *The subject of the acceptance criteria is not within the scope of the applicable codes*: A report issued by ICC-ES is intended to provide a basis for approval under the codes. If the subject of the acceptance criteria is not regulated by the codes, there is no basis for issuing a report, or a criteria. (Specifics must be provided concerning the inapplicability of the code.)

d. *The subject of the acceptance criteria needs to be discussed in a public hearings*. The committee member requests additional input from other committee members, staff or industry.

5.3 An Evaluation Committee member, in voting on an acceptance criteria, may only cast the following ballots:

- Approved
- Approved with Comments
- Negative: Do Not Proceed

6.0 COMMITTEE COMMUNICATION

Direct communication between committee members, and between committee members and an applicant or concerned party, with regard to the processing of a particular acceptance criteria or evaluation report shall take place only in a public hearing of the Evaluation Committee. Accordingly:

6.1 Committee members receiving an electronic ballot should respond only to the sender (staff). Committee members who wish to discuss a particular matter with other committee members, before reaching a decision, should ballot accordingly and bring the matter to the attention of ICC-ES staff, so the issue can be placed on the agenda of a future committee meeting.

6.2 Committee members who are contacted by an applicant or concerned party on a particular matter that will be brought to the committee will refrain from private communication and will encourage the applicant or concerned party to forward their concerns through the ICC-ES staff in writing, and/or make their concerns known by addressing the committee at a public hearing, so that their concerns can receive the attention of all committee members. ■

Effective March 18, 2008

PROPOSED REVISIONS TO THE ACCEPTANCE CRITERIA FOR STEEL DECK ROOF AND FLOOR SYSTEMS

AC43

Proposed ~~December 2009~~ May 2010

Previously approved February 2008, October 2007, June 2006, February 2006,
October 2004, January 2002, July 1996

PREFACE

Evaluation reports issued by ICC Evaluation Service, Inc. (ICC-ES), are based upon performance features of the International family of codes and other widely adopted code families, including the Uniform Codes, the BOCA National Codes, and the SBCCI Standard Codes. Section 104.11 of the *International Building Code*® reads as follows:

The provisions of this code are not intended to prevent the installation of any materials or to prohibit any design or method of construction not specifically prescribed by this code, provided that any such alternative has been approved. An alternative material, design or method of construction shall be approved where the building official finds that the proposed design is satisfactory and complies with the intent of the provisions of this code, and that the material, method or work offered is, for the purpose intended, at least the equivalent of that prescribed in this code in quality, strength, effectiveness, fire resistance, durability and safety.

Similar provisions are contained in the Uniform Codes, the National Codes, and the Standard Codes.

ICC-ES may consider alternate criteria, provided the report applicant submits valid data demonstrating that the alternate criteria are at least equivalent to the criteria proposed in this document, and otherwise meet the applicable performance requirements of the codes. Notwithstanding that a product, material, or type or method of construction meets the requirements of the criteria proposed in this document, or that it can be demonstrated that valid alternate criteria are equivalent to the criteria in this document and otherwise meet the applicable performance requirements of the codes, ICC-ES retains the right to refuse to issue or renew an evaluation report, if the product, material, or type or method of construction is such that either unusual care with its installation or use must be exercised for satisfactory performance, or malfunctioning is apt to cause unreasonable property damage or personal injury or sickness relative to the benefits to be achieved by the use of the product, material, or type or method of construction.

Acceptance criteria are developed for use solely by ICC-ES for purposes of issuing ICC-ES evaluation reports.

PROPOSED REVISIONS TO THE ACCEPTANCE CRITERIA FOR STEEL DECK ROOF AND FLOOR SYSTEMS

1.0 INTRODUCTION

1.1 Purpose: The purpose of this criteria is to establish requirements for steel deck roof and floor systems to be recognized in an ICC Evaluation Service, Inc. (ICC-ES), evaluation report under the ~~2006~~ 2009 *International Building Code*[®] (IBC) and the ~~1997~~ *Uniform Building Code*[™] (UBC). ~~Bases~~ The basis of recognition are is IBC Section 104.11 and ~~UBC Section 104.2.8.~~

The reason for the development of this criteria is to provide a guideline for the evaluation of steel deck floor and roof systems, since the prescriptive requirements of Chapter 22 of the IBC and ~~Chapter 22 of the UBC~~ do not provide requirements for the systems being used as diaphragms or composite slabs.

1.2 Scope: This acceptance criteria is applicable to steel deck roof and floor systems consisting of steel deck panels attached to steel supports, with or without a concrete fill placed on top of the steel deck panels, where the concrete is structural normal-weight concrete, structural lightweight concrete or insulating concrete. This acceptance criteria is applicable to systems using power-actuated fasteners, tapping screws, welds, button punches or proprietary panel-to-panel mechanical ~~connections~~ devices such as clinch connections. The systems under this acceptance criteria may also include accessories, such as devices used to transfer shear forces at diaphragm boundaries.

This acceptance criteria is applicable to steel deck floor and roof systems used to support a gravity load and resist uplift loads; used as a component of horizontal diaphragms to resist lateral forces; and used as in fire-resistance-rated assemblies. Suitability of cellular deck panels for use as cellular metal floor raceways is outside the scope of this acceptance criteria.

Steel deck roof systems used as roof coverings also shall comply with requirements set forth in the ICC-ES Acceptance Criteria for Metal Roof Coverings (AC166).

1.3 Codes and Reference Standards:

1.3.1 ~~2006~~ 2009 *International Building Code*[®], International Code Council.

~~1.3.2~~ ~~1997~~ *Uniform Building Code*[™].

1.3.3 American Iron and Steel Institute (AISI):

~~1.3.3.1~~ ~~Specification for Design of Cold-Formed Steel Structural Members, 1986 with December 1989 addendum (referred to as 1986 ASD Specifications).~~

~~1.3.3.2~~ ~~Load and Resistance Factor Design Specification for Cold-Formed Steel Structural Members, March 1991, (referred to as 1991 LRFD Specifications).~~

~~1.3.3.3~~ ~~Specification for the Design of Cold-Formed Steel Structural Members, 1996 edition, (referred to as 1996 Specifications).~~

1.3.3.4 ~~AISI-NAS-04~~ S100-2007, North American Specification for the Design of Cold-formed Steel Structural Members, ~~2004~~ 2007 edition ~~with 2004 Supplement~~. The United States provisions under Appendix A of ~~AISI-NAS~~ S100 are applicable under this acceptance criteria.

1.3.3.5 ~~AISI TS-4-02~~ S904-08, Standard Test Methods for Determining the Tensile and Shear Strength of Screws, Part VI, AISI Manual - Cold-Formed Steel Design, ~~2002~~ 2008 edition.

1.3.3.6 ~~AISI TS-5-02~~ S905-08, Test Methods for Mechanically Fastened Cold-Formed Steel Connections, Part VI, AISI Manual - Cold-Formed Steel Design, ~~2002~~ 2008 edition.

1.3.3.7 AISI S907-08, Test Standard for Cantilever Test Method for Cold-Formed Steel Diaphragms, Part VI, AISI Manual - Cold-Formed Steel Design, 2008 edition.

1.3.3.8 AISI S909-08, Standard Test Method for Determining the Web Crippling Strength of Cold-Formed Steel Beams, Part VI, AISI Manual - Cold-Formed Steel Design, 2008 edition.

1.3.4 TM 5-809-10, Seismic Design for Buildings, Departments of the Army, Navy and Air Force, 1982.

1.3.5 Steel Deck Institute (SDI):

1.3.5.1 Diaphragm Design Manual, Third Edition, No. DDM03, 2004, including errata issued November 2006.

1.3.5.2 Composite Steel Deck Design Handbook, No. CDD2, March 1997.

1.3.5.3 ANSI/SDI NC1.0-06 Standard for Noncomposite Steel Floor Deck.

1.3.5.4 ANSI/SDI RD1.0-06 Standard for Steel Roof Deck.

1.3.5.5 ANSI/SDI C1.0-06 Standard for Composite Steel Floor Deck.

1.3.6 American Society of Civil Engineers (ASCE):

1.3.6.1 Standard for the Structural Design of Composite Slabs, ANSI/ASCE 3-91, ~~ASCE~~, 1994.

1.3.6.2 ASCE/SEI 7-05, Minimum Design Loads for Buildings and Other Structures, American Society of Civil Engineers.

**PROPOSED REVISIONS TO THE ACCEPTANCE CRITERIA
FOR STEEL DECK ROOF AND FLOOR SYSTEMS**

1.3.7 Design and Control of Concrete Mixtures, 13th edition, Portland Cement Association, 1988.

1.3.8 American Concrete Institute (ACI):

1.3.8.1 ACI Standard 211.1, Standard Practice for Selecting Proportions for Normal Weight, Heavy Weight and Mass Concrete, ACI, 1991.

1.3.8.2 ACI Standard 211.2, Standard Practice for Selecting Proportions for Structural Lightweight Concrete, 1998.

1.3.8.3 ACI Standard ~~318-05~~ 318-08, Building Code Requirements for Structural Concrete, ~~2005~~ 2008.

1.3.8.4 ACI 216.1-~~97~~ 07, Method for Determining Fire Resistance of Concrete and Masonry Construction Assemblies, 1997.

1.3.9 Underwriters Laboratories (UL):

1.3.9.1 ~~Underwriters Laboratories~~ UL Standard 209, Standard for Cellular Metal Floor Raceways and Fittings 9th edition, 1987.

1.3.9.2 UL Standard 263-03, Standard for Fire Test of Building Construction and Materials, Underwriters Laboratories Inc.

1.3.10 ASTM International (ASTM):

1.3.10.1 Standard Test Methods and Definitions for Mechanical Testing of Steel Products (ASTM A 370).

1.3.10.2 Standard Specifications for Steel Sheet, Electrolytic Zinc-Coated, for Light Coating Weight [Mass] Applications (ASTM A 591).

1.3.10.3 Standard Specification for Steel Sheet, Zinc-Coated (Galvanized) or Zinc-Iron Alloy-Coated (Galvannealed) by the Hot-Dip Process (ASTM A 653).

1.3.10.4 Standard Specification for General Requirements for Steel Sheet, Metallic-Coated by the Hot-Dip Process (ASTM A 924).

1.3.10.5 Standard Practice for Making and Curing Concrete Test Specimens in the Field (ASTM C 31).

1.3.10.6 Standard Specification for Concrete Aggregates (ASTM C 33).

1.3.10.7 Standard Test Method for Compressive Strength of Cylindrical Concrete Specimens (ASTM C 39).

1.3.10.8 Standard Test Method for Density, Relative Density (Specific Gravity) and Absorption of Coarse Aggregate (ASTM C 127).

1.3.10.9 Standard Specification for Lightweight Aggregates for Structural Concrete (ASTM C 330).

1.3.10.10 Standard Specification for Lightweight Aggregates for Insulating Concrete (ASTM C 332).

1.3.10.11 Standard Test Method for Compressive Strength of Lightweight Insulating Concrete (ASTM C 495).

1.3.10.12 Standard Test Method for Foaming Agents for Use in Producing Cellular Concrete Using Preformed Foam (ASTM C 796).

1.3.10.13 Standard Specification for Foaming Agents Used in Making Preformed Foam for Cellular Concrete (ASTM C 869).

1.3.10.14 Standard Test Methods of Conducting Strength Tests of Panels for Building Construction (ASTM E 72).

1.3.10.15 Test Methods for Fire Tests of Building Construction and Materials (ASTM E 119).

1.3.11 American Institute of Steel Construction (AISC):

~~**1.3.11.1** AISC 335-89, Specification for Structural Steel Buildings – Allowable Stress Design and Plastic Design – 9th edition, 1989.~~

~~**1.3.11.2** AISC-LRFD (1993), Load and Resistance Factor Design Specification for Structural Steel Buildings – 2nd edition, 1993.~~

1.3.11.1 ~~1.3.11.3~~ AISC 360-05, Specification for Structural Steel Buildings.

~~**1.3.12** ASCE/SEI 7-05, Minimum Design Loads for Buildings and Other Structures, American Society of Civil Engineers. (moved to 1.3.6 above)~~

1.4 Definitions:

1.4.1 Base-metal Thickness: Thickness of steel sheets used to form the steel deck panels, exclusive of all coatings and galvanization thicknesses.

1.4.2 Composite Slab: A steel deck system with a structural concrete fill placed onto the steel deck panels, with reinforcement within the concrete as required for such purposes as the control of shrinkage and temperature effects as required by the applicable code and negative moment reinforcement for designs requiring negative moment reinforcement. The steel deck panels typically have web embossments or other shear connection devices to develop a mechanical bond between the steel deck and the structural concrete fill so that the concrete and steel deck panels compositely resist applied vertical loads.

**PROPOSED REVISIONS TO THE ACCEPTANCE CRITERIA
FOR STEEL DECK ROOF AND FLOOR SYSTEMS**

1.4.3 Noncomposite Slab: A steel deck system with a concrete fill placed onto the steel deck panels, with the vertical loads on the assembly designed without composite behavior between the steel deck panels and concrete.

1.4.4 Plain Steel Roof Deck: A steel deck roof system consisting of steel deck panels without concrete fill.

1.4.5 Diaphragm: Horizontal floor, or horizontal or sloped roof assembly, that distributes wind, earthquake and other lateral forces to the vertical lateral force resisting system. Analogous to a horizontal girder with interconnected floor or roof deck panels acting as the girder web. Intermediate joists or beams act as web stiffeners and provide vertical load support. Perimeter steel beams or perimeter concrete or masonry elements with reinforcement, act as girder flanges. Diaphragms under this acceptance criteria may be plain steel roof decks, composite slabs or noncomposite slabs.

1.4.6 Cellular Deck Panels: Fluted steel deck panels, resistance-welded to an essentially flat sheet or another fluted steel deck panel at a factory.

1.4.7 Fluted Deck Panels: Steel deck panels with flanges in various patterns alternating from top to bottom.

1.4.8 Steel Deck Panels: Sheets of steel, cold-formed into fluted or cellular decks with specified width and variable length.

1.4.9 Bare Frame: Steel members assembled to form the test frame of the diaphragm without the diaphragm's web of steel deck panels installed onto the frame.

1.4.10 Full Frame: Steel deck panels installed and attached to a bare frame to form the diaphragm test specimen.

1.4.11 Standard Deck Panels: Standard deck panels ~~are include~~ a wide variety of smooth surface panel profiles including the narrow rib, intermediate rib, wide rib and hat profiles. Such panels may vary in nominal depth from $\frac{9}{16}$ inch to 7.5 inches, with design thicknesses from 0.014 inch to 0.071 inch.

1.4.12 Generic Screw: A generic screw is used in both structural and side-lap connections. DDM03 indicates the connection strength and stiffness required for a generic screw in Equations 4.5-1, 4.5-2, 4.5.1-1 and 4.5.1-2. For side lap fasteners, a generic screw shall also meet the requirements of ASTM C 1513.

1.4.13 Proprietary Fastener: ~~Means to attach with screws, pins, and etc.~~ Fasteners such as a screw or power-actuated fastener that does not meet the definition of a generic screw above.

1.4.14 Mechanical Device: A crimp or other means of connecting two or more sheets of steel deck together without the introduction of additional material, such as fastener or weld.

2.0 BASIC INFORMATION

2.1 General: The following information shall be submitted:

2.1.1 Data concerning product specifications:

2.1.1.1 Steel Deck Panels: The product specifications to be submitted for the steel deck panels shall include the specifications for the steel, including the base-metal thickness; applicable standards and grade; coatings, including type and thickness; and dimensioned cross-sectional drawings of the panels with stated tolerances. The drawings shall illustrate the fluted patterns and web embossments, if any. For cellular decks, the resistance weld pattern and a description of the welds shall be reported and shown on the drawings.

2.1.1.2 Insulating Concrete with Aggregate: The product specifications for the insulating concrete with aggregates shall include the concrete mix design, and description and specifications for the concrete constituents. In addition, the aggregate shall be described by group, rock and mineral components, expansion process, shape, maximum size, grading specification and unit weight.

2.1.1.3 Cellular Concrete: The product specification requirements for the cellular concrete are as noted in the ICC-ES Acceptance Criteria for Cellular Concrete (AC272).

2.1.1.4 ~~Power Actuated Fasteners Connections:~~ The product specification requirements for power-actuated fasteners are as noted in the ICC-ES Acceptance Criteria for Fasteners Power-driven into Concrete, Steel and Masonry Elements (AC70). All connections shall be described completely. ~~If proprietary fasteners are used (pins or screws), the fastener must have a valid ICC-ES report that shows the information required in Section 3.0 of this criteria. If the proprietary fastener does not have a valid ICC-ES report, testing is required as set forth in Section 3.1.4 of this criteria.~~ If proprietary fasteners are used, complete fastener specifications shall be submitted which include the applicable standards; material specifications and grade; coating specifications, including type and thickness; and dimensioned drawings with stated tolerances. Alternatively, the fasteners shall be recognized in an ICC-ES evaluation report. If mechanical devices are used, a description of the method of forming the mechanical device in the field must be submitted. Where proprietary mechanical devices are used, dimensioned drawings showing the final condition of the deck shall be submitted.

~~Connections containing welds, button punches and generic screws used in connections must fulfill the same requirements as given in DDM03.~~

~~Connections containing other mechanical devices must provide testing as required in Section 3.1.4 of this criteria.~~

2.1.1.5 ~~Tapping Screws:~~ The product specification requirements for tapping screws are as noted in the ICC-ES Acceptance Criteria for Tapping Screw Fasteners (AC418).

2.1.2 Packaging and Identification:

PROPOSED REVISIONS TO THE ACCEPTANCE CRITERIA FOR STEEL DECK ROOF AND FLOOR SYSTEMS

2.1.2.1 Steel Deck Panels: Each bundle of steel deck panels shall have a legible label, stamp or embossment, indicating the manufacturer's name, logo or initials; the evaluation report number; and the acronym "ICC-ES." In addition to the above information, each bundle of panels shall have a legible label, also indicating material minimum base metal thickness (uncoated) in decimal thickness or mils; minimum specified yield strength [if greater than 33 ksi (228 MPa)]; ~~and identification in accordance with Section 2203.3 of the UBC.~~ The label on each bundle of cellular deck panels shall include the logo of the inspection agency.

2.1.2.2 Insulating Concrete with Aggregate: The packaging of the aggregate for insulating concrete with aggregate shall be labeled. At a minimum, the label shall include the evaluation report number.

2.1.2.3 Cellular Concrete: The packaging and labeling requirements for cellular concrete are as noted in AC272.

2.1.2.4 ~~Power-actuated Fasteners~~ Proprietary Fasteners: ~~The packaging and labeling requirements for power-actuated fasteners are as noted in AC70. A description of the method of packaging and manner of field identification shall be submitted. The manufacturer's name or insignia and the product's type and size shall be marked on the fastener or packaging units. The ICC-ES evaluation report number shall be placed on the packaging.~~

2.1.2.5 Tapping Generic Screws: The packaging and labeling requirements for ~~tapping generic~~ screws are as noted in AC118.

2.1.3 Installation instructions.

2.2 Testing Laboratories: Testing laboratories shall comply with Section 2.0 of the ICC-ES Acceptance Criteria for Test Reports (AC85) and Section 4.2 of the ICC-ES Rules of Procedure for Evaluation Reports.

2.3 Test Reports: Test reports shall comply with AC85 and additionally include the following information:

2.3.1 Detailed identification of specimens.

2.3.2 Detailed drawings of specimens, describing physical characteristics and including section profiles of the steel deck panels and other construction details.

2.3.3 Detailed descriptions of test specimens and test assemblies, attachment of specimens to the fixture, location of load points, deflection gages, deflection points and other items as applicable. Ambient conditions at the date of construction, curing period and date and time of tests shall be reported where relevant to the performance of the tested assembly. The ambient conditions include relative humidity, temperature and wind speed.

2.3.4 Results of tests on individual materials, in accordance with Section 4.4, shall be included. If the test specimen construction deviates from typical field construction, deviations shall be reported.

2.3.5 The test report shall state that tests were conducted in accordance with the applicable methods and the ICC-ES acceptance criteria.

2.3.6 Statements indicating whether the constructed test specimens meet actual or intended construction shall be included. If the test specimen construction deviates from typical field construction, deviations shall be reported.

2.3.7 Test results shall be reported, including load-deflection readings, a maximum load applied, failure mode, total time under load at the various load levels and photographs of tested specimens before and after testing.

2.4 Product Sampling: Sampling of the steel deck panels, concrete constituents and fasteners for tests under this criteria shall comply with Section 3.2 of AC85.

3.0 TEST AND PERFORMANCE REQUIREMENTS

3.1 Components:

3.1.1 Steel Deck Panels:

3.1.1.1 Steel: Steel specifications shall comply with ~~Section A.3 of the 1986 ASD Specifications, 1991 LRFD Specifications or 1996 Specifications, or~~ Section A2 of AISI-NAS S100.

3.1.1.2 Galvanized Finish: For galvanized steel, the galvanized coating shall be described and shown to comply with ~~the applicable ASTM standard~~ ASTM A-924. Coating weight shall be verified in accordance with the standard.

3.1.1.3 Paint Finish: The type of paint used for painted decking shall be described.

3.1.1.4 Phosphatized Finish: The temporary preservative coating applied to surfaces receiving concrete fill shall be described.

3.1.1.5 Minimum steel thickness shall comply with ~~Section A3.4 of the 1986 ASD Specifications, 1991 LRFD Specifications or 1996 Specifications, or~~ Section A2.4 of AISI-NAS S100.

3.1.2 Insulating Concrete with Aggregate: Reports of tests shall be submitted that demonstrate that the aggregates for insulating concrete comply with ASTM C 332.

3.1.3 Cellular Concrete: Cellular concrete shall be recognized in an evaluation report based on evaluation of the cellular concrete for compliance with AC272.

3.1.4 ~~Power-actuated Fasteners:~~ Power-actuated Fasteners: ~~Power-actuated fasteners shall be recognized in an evaluation report on the fasteners. As a minimum, the evaluation report on the fasteners shall be based on verification that the~~

**PROPOSED REVISIONS TO THE ACCEPTANCE CRITERIA
FOR STEEL DECK ROOF AND FLOOR SYSTEMS**

fasteners comply with the fastener manufacturer's specifications, as required by AC70. For use of the fasteners in diaphragms of steel deck roof and floor systems, the shear strength and shear stiffness of the diaphragm shall be determined by using one of the references in Section 3.3.1 or shall be established by testing under Section 3.3.2.

3.1.4.1 Generic Screws: Compliance with ASTM C 1513 shall be established in accordance with AC118. For generic screws used to attach deck to supports, tension and shear strength of the fasteners shall be determined and controlled in accordance with Section 3.1.4.2

3.1.4.2 Proprietary Fasteners: Tension and shear strength of the fasteners shall be determined in accordance with AISI S904. When full scale diaphragm testing is required, the fasteners tested in accordance with AISI S904 shall be from the same lot of fasteners used in the diaphragm testing. A minimum of three identical fasteners shall be tested. If the deviation from the average exceeds ± 15 percent, three additional tests shall be conducted.

Fastener specifications shall ensure consistent structural performance. This may be done by using the tested fastener strengths as target values for ongoing quality control testing.

A minimum of 5 replicate fasteners specimens shall be measured and tested for compliance with the manufacturer's specifications, including material, dimensional and mechanical specifications.

The fasteners shall have a corrosion-resistant treatment and shall be tested in accordance with ASTM B 117 for a minimum 12-hour test period. Screws shall not show products of corrosion from the coating (white corrosion) after three hours, and shall not show corrosion from the base metal (red rust) at the end of the test period.

~~**Connections:** Connections in this criteria refer to the attachment of steel deck panels to supports and attachment of sheet steel to sheet steel at panel sidelaps. The attachment methods include power actuated fasteners, tapping screws, welds and other mechanical means for which connection performance can be predicted reliably. Table 3 is a matrix of connection methods and what is required for each connection scheme (deck type, attachment to support and sidelap). For use in diaphragms of steel deck roof and floor systems, the shear strength and stiffness of the diaphragm shall be determined by calculation under Section 3.3.1 or shall be established by testing under Section 3.3.2.~~

3.1.5 Tapping Screws: Tapping screws shall be recognized in an evaluation report based on evaluation of the tapping screws for compliance with AC118 as modified by AISI-NAS. For use in diaphragms of steel deck roof and floor systems, the shear strength and stiffness of the diaphragm shall be determined by using one of the references in Section 3.3.1 or shall be established by testing under Section 3.3.2.

3.2 Steel Deck Panels: Evaluation reports on steel deck panels shall address the section property and web crippling requirements in Sections 3.2.1 and 3.2.2 of this criteria:

3.2.1 Section Properties: Section properties shall be determined in accordance with AISI-NAS S100 for recognition under the IBC; and 1986 ASD Specifications, 1991 LRFD Specifications or 1996 Specifications for recognition under the UBC. The section properties reported shall include the base-metal design thickness; full moment of inertia (I_x); effective moment of inertia, normal position (I_{on}); effective moment of inertia, inverted position (I_{oi}); effective section modulus, normal position (S_{en}) at F_y ; and effective section modulus, inverted position (S_{ei}) at F_y . In lieu of section moduli, nominal moment strength, M_n , is permitted. Under uniform loads, any of the following equations are permitted to determine deflections:

$$\text{Simple span: } I_D = (I_x + 2I_{on}) / 3, \text{ or } I_{on}$$

$$\text{Multiple span: } I_D = (I_x + 2I_{oi}) / 3, (I_x + 2I_{on}) / 3, \text{ or the minimum of } I_{on} \text{ and } I_{oi}$$

3.2.2 Web Crippling: Web crippling values shall be determined in accordance with Section C3.4 of AISI-NAS S100 for recognition under the IBC; and Section C3.4 of the 1986 ASD Specifications, 1991 LRFD Specifications, or 1996 Specifications for recognition under the UBC. For decks with R/t , N/t or N/h ratios that exceed limitations specified in the applicable specifications, or modified elements, such as perforations, full-scale tests are necessary to determine applicable end reactions and interior reactions. See Section 4.1 of this criteria.

3.2.3 Load-spans (Optional): As an option, load versus span information for gravity loads and wind loads may be developed based on strength requirements in AISI-NAS for recognition under the IBC; and 1986 ASD Specifications, 1991 LRFD Specifications or 1996 Specifications for recognition under the UBC; deflection limitations in IBC Section 1603.1 or UBC Section 1613; and section properties and web crippling values in Sections 3.2.1 and 3.2.2, respectively. For steel deck roof systems evaluated under the IBC, For inclusion of load/span tables in the evaluation reports, steel roof deck panels shall be evaluated for uniform dead load combined with the uniform live loads required by IBC Section 1607.3 and modified by IBC Section 1607.11 or the 300-pound (1334 N) concentrated design live load required by IBC Section 1607.4 and Table 1607.1, whichever produces the greater load effects. Noncomposite steel floor deck panels' and steel roof deck panels' load-versus-span information for gravity loads and wind loads shall ~~must~~ be developed based on deflection limitations in IBC Section 1603.1 and section properties and web crippling values in Sections 3.2.1 and 3.2.2, respectively, using one of the following methods:

3.2.3.1 Noncomposite steel floor decks shall be designed in accordance with ANSI/SDI-NC1.0 with changes as indicated in Section 2209.2.2.1 of the IBC.

3.2.3.2 Steel roof decks shall be designed in accordance with ANSI/SDI-RD1.0 as indicated in Section 2209.2.3 of the IBC.

3.2.3.3 Steel roof decks shall be designed in accordance with AISI S100 for recognition under the IBC.

PROPOSED REVISIONS TO THE ACCEPTANCE CRITERIA FOR STEEL DECK ROOF AND FLOOR SYSTEMS

~~3.2.3.4 Steel roof decks shall be designed in accordance with the 1986 ASD Specifications, 1991 LRFD Specifications or 1996 Specifications for recognition under the UBC.~~

~~3.2.3.4 3.2.3.5~~ Other rational methods of analysis for design of noncomposite steel floor decks or steel roof decks, exceeding the scope of Sections 3.2.3.1 through 3.2.3.3, will be considered with prior concurrence of the ICC-ES staff.

3.3 Diaphragms: For steel deck roof and floor systems used as a diaphragm, the shear strength and shear stiffness of the steel deck panels as the web of the diaphragm shall be determined by using one of the references in Section 3.3.1, or shall be established by testing under Section 3.3.2:

3.3.1 Diaphragm Design References Methods:

3.3.1.1 Technical Manual 5-809-10, Seismic Design for Buildings, Section 5-6 for Bare and Concrete Filled Assemblies, Departments of the Army, Navy and Air Force, 1982.

In order to determine the shear strength and stiffness of the diaphragm, Technical Manual 5-809-10 provides shear strength and stiffness equations for connections using welds. These equations can be used under this criteria, if the connection scheme includes these types of connections. However, generic screws, power-actuated fasteners, proprietary screws and other mechanical means of connection shall be evaluated using full scale testing using Section 4.2 of this criteria. The results of the test data shall be presented by means of the equations or tables similar to that used in Sections 5-6b, 5-6c and 5-6c of Technical Manual 5-809-10.

3.3.1.2 Diaphragm Design Manual, No. DDM03, ~~shall be used with the following modifications:~~

3.3.1.2.1 SDI Method: Diaphragm strength and stiffness of standard deck panels (See Section 1.4.11) shall be determined in accordance with the Diaphragm Design Manual, No. DDM03, excluding Section 4.6. Strength and stiffness of connections made using proprietary fasteners or mechanical devices shall be evaluated using AISI S905, as indicated in Table 3, prior to utilizing the diaphragm equations in DDM03. As stated in Section F1.1(c) of AISI S100, if the ultimate strength and the thickness of the steel from which the S905 test sections are formed are greater than the specified values, the test results shall be reduced. The adjustment factor, R_s , shall be determined as follows:

$$R_s = \left(\frac{F_{u(\text{specified})}}{F_{u(\text{tested})}} \right) \times \left(\frac{t_{(\text{specified})}}{t_{(\text{tested})}} \right) \leq 1.0$$

As indicated in Section 10.3 of AISI S905-08, if the Φ and Ω values determined for the tested connections are more severe than the values in AISI S100 Table D5, full-scale testing of the diaphragm system shall be required. When full-scale testing is required test and analytical data supporting derivation of diaphragm shear strength, diaphragm stiffness, factors of safety, and resistance factors shall be submitted. Factors of safety and resistance factors shall be no less critical than values in Section D5 of AISI-S100.

3.3.1.2.2 Diaphragm Design Manual, No. DDM03, modifications:

(1) Section 1.2: The sixth paragraph is revised as follows:

The design recommendations in the following sections are limited to properly interconnected diaphragm steel deck panels having design thicknesses between 0.0147 inch (0.37 mm) and 0.0747 inch (1.90 mm) with steel deck panel depths between the nominal limits of $\frac{9}{16}$ inch (14 mm) and 7.5 inches (190 mm).

~~(2) Section 2.4: Add the following notes to Table 2.1:~~

~~For use under the UBC, Factors of Safety and Resistance Factor shall be as set forth in Section D5 of the 1986 ASD Specification, 1991 LRFD Specifications, or 1996 Specifications.~~

(3) Section 2.6: Revised the second paragraph under the section Load Tables as follows:

While the appended tables address specific profiles, the formulas on which they are based have been checked against full-scale diaphragm tests on steel deck panels ranging in nominal depths from $\frac{9}{16}$ inch (14 mm) and 7.5 inches (190 mm) with design thicknesses from 0.0147 inch (0.37 mm) to 0.0747 inch (1.90 mm). The design formulas are applicable to these ranges and appropriate design tables can be developed from them.

(4) Section 3.2: Add the following to Eq. 3.2-3: For cellular deck panels the equation is Eq. 3.2-3a.

$$G' = \frac{Et}{A_A + \emptyset D_n + C} \quad \text{Eq. 3.2-3a}$$

where:

$$A_A = \left(\frac{2.6 D_{DL}}{1 + D_{DL} t_b / t} \right)$$

**PROPOSED REVISIONS TO THE ACCEPTANCE CRITERIA
FOR STEEL DECK ROOF AND FLOOR SYSTEMS**

- D_{DL} = Developed top unit width per pitch, divided by d .
- = $(2(e + w) + f)/d$
- d = Cell pitch, in., (mm).
- t = top unit thickness, in (mm).
- t_b = bottom panel thickness, in. (mm).

$$D_n = \frac{D_{nt}}{(1 + t_b/t)}$$

If

$$D_n \left(\frac{1}{3D_d(t_b/t)^3} \right) \leq D_n$$

- D_d = Depth of steel deck panel, in. (mm)
- D_n = Panel warping constants
- D_{nt} = Panel warping constant for top element (see Section 3.3 in DDM03)
- D_d = Depth of steel deck panel, in. (mm)

$$D_n = D_{nt}$$

If

$$D_n (1/(3D_d(t_b/t)^3)) > D_n$$

~~For generic screws described in DDM03, the shear strength and stiffness of the diaphragm shall be determined by using the equations in DDM03.~~

~~As indicated in Section 10.3 of AISI S905-08, if the tested connections have determined omega and phi (Ω and ϕ) values that are greater than or less than, respectively, the values in AISI S100 Table D5, full-scale testing of the diaphragm system shall be required.~~

~~In order to determine the shear strength and stiffness of the diaphragm, DDM03 provides shear strength and stiffness equations for connections using welds, generic screws and button punches. These equations can be used under this criteria, if the connection scheme includes these types of connections. However, power actuated fasteners, proprietary screws and other mechanical means of connection must be evaluated using AISI S906, as indicated in Table 3, prior to utilizing the equations in DDM03.~~

~~As stated in Section E1.1(e) of AISI S100, if the ultimate strength and the thickness of the steel from which the test sections are formed are greater than the specified values, the test results shall be reduced. The adjustment factor shall be the ratio of the specified ultimate steel strength and thickness over the actual ultimate steel strength and thickness.~~

$$\frac{F_{u(\text{specified})} \times t_{(\text{specified})}}{F_{u(\text{actual})} \times t_{(\text{actual})}} \leq 1.0$$

~~For proprietary fasteners described in DDM03, test and analytical data supporting derivation of diaphragm shear strength, diaphragm stiffness, factors of safety, and resistance factors shall be submitted. Factors of safety and resistance~~

PROPOSED REVISIONS TO THE ACCEPTANCE CRITERIA FOR STEEL DECK ROOF AND FLOOR SYSTEMS

~~factors shall be no less critical than values in Section D5 of AISI-NAS S100, 1996 AISI Specifications, 1986 AISI ASD Specifications or 1991 AISI-LRFD Specifications.~~

3.3.1.3 ACI 318, for reinforced structural concrete filled steel deck panels attached to steel supports with headed stud shear connectors, with the analysis based on the minimum thickness of concrete above the top of the steel deck panels. The shear strength of each headed stud shear connector shall be as specified in Chapter I of AISC 360 (IBC), or AISC 335 or AISC LRFD (UBC).

3.3.2 Diaphragm Test Method: For diaphragms of steel deck roof and floor systems ~~that are outside the scope of the diaphragm design references in Section 3.3.1 that cannot be calculated in accordance with Section 3.3.1 DDM03,~~ including but not limited to composite slabs without headed stud shear connectors and noncomposite slabs with insulating concrete fill, the shear strength and shear stiffness shall be established in accordance with the testing and analysis requirements of this section (Section 3.3.2).

Diaphragm load tests shall be conducted in accordance with the test method described in Section 4.2 of this acceptance criteria. In addition, the components and the properties of the components of the load tested diaphragm assemblies shall be verified, as required by the applicable testing specified in Section 4.4.

The shear strength, S_u , and shear stiffness, G' , of the steel deck panels as the web of the diaphragm depend on the steel deck panel geometry, base-metal thickness, ~~panel~~ steel grade and width, w , support spacing, L_v ; the type and spacing of the steel deck panel attachment to the support framing perpendicular to the flutes; the type and spacing of connectors attaching the steel deck panels together along the panel seams; the type and spacing of the steel deck panel attachment to framing parallel to the flutes; and the method of attachment at steel deck panel end laps. The performance of steel deck roof and floor systems with concrete fill also depends on the concrete type, compressive strength and thickness; as a result, the diaphragm testing shall address these variations.

3.4 Vertical Loads on Composite Slabs: The vertical load capacity of composite slabs shall be determined using one of the following methods:

3.4.1 For reinforced structural concrete filled steel deck panels without headed steel shear studs, the design and analysis shall comply with ANSI/ASCE 3-91. Testing shall comply with Section 4.3 of this criteria, with verification of components of the load tested assemblies verified as required by Section 4.4.

3.4.2 For reinforced structural concrete filled steel deck panels with and without headed stud shear connectors, the design and analysis shall comply with ANSI/SDI C1.0-06 and SDI CDD2.

3.4.3 Other rational methods of analysis for design of reinforced concrete composite slabs, exceeding the scope of Sections 3.4.1 and 3.4.2, will be considered with prior concurrence of the ICC-ES staff.

3.5 Cellular Decks: To fully develop section properties of the assembled steel deck panel, welds shall be placed to develop the shear flow at the intersection of the two sheets. Resistance weld strengths shall be in compliance with Section E2.6 of AISI-NAS S100 ~~for use under the IBC; and shall be in compliance with Section E2.6 of the 1986 ASD Specifications, 1991 LRFD Specifications or 1996 Specifications for use under the UBC.~~

3.6 Fire-resistance-rated Roof and Floor-ceiling Assemblies: For inclusion of fire-resistance-rated roof and floor-ceiling assemblies in the evaluation report, reports of fire tests shall be submitted. ~~For use under the IBC, the~~ The tests shall be conducted in accordance with ASTM E 119 or UL 263. ~~For use under the UBC, the tests shall be conducted in accordance with UBC Standard 7-4.~~

3.7 Uplift Capacity: When proprietary fasteners are used to attach deck panels to supports, the uplift resistance of these connections shall be determined in accordance with AISI S905. See Table 3.

4.0 TEST METHODS

4.1 Web Crippling:

4.1.1 Procedure: For steel deck panels with modifications such as perforations, or ratios exceeding limitations in Section C3.4 of AISI-NAS S100 ~~used under the IBC and Section C3.4 of the 1986 ASD Specifications, 1991 LRFD Specifications or 1996 Specifications used under the UBC,~~ testing shall be conducted in accordance with AISI-S909 or as an alternate, Section 11 of ASTM E 72 on three similar specimens per test series. Two series are required for each steel deck panel profile: one series for interior reactions and a second series for end reactions. ~~The series for interior reactions may be waived if the results for end reactions exceed values determined by Section C3.4 of the applicable specification. If ASTM E 72 is used,~~ The test assembly described in Figure 3 of ASTM E 72 may be modified to place the loading plates at a location that will ensure web crippling failure as opposed to other failure modes for the deck. Both end reactions and interior reactions shall be evaluated in accordance with the conditions set forth in the applicable specification. The tested bearing width will be the minimum and maximum width recognized in the report. For deck profiles available in multiple thicknesses, ~~only the least minimum and maximum~~ thickness in each profile is required to be tested except as set forth in Section 4.1.3.

4.1.2 Conditions of Acceptance: The decks shall be loaded to failure or dysfunctional distortions and the loads causing web crippling shall be recorded. The determination of nominal resistance, R_n , shall be based on Sections F1 of AISI-NAS S100 ~~used under the IBC and Sections F1 of the 1986 ASD Specifications, 1991 LRFD Specifications or 1996 Specifications used under the UBC.~~ For ASD, the allowable design strength, R_a , is as follows:

$$R_a = R_n/\Omega.$$

PROPOSED REVISIONS TO THE ACCEPTANCE CRITERIA FOR STEEL DECK ROOF AND FLOOR SYSTEMS

where:

$$\Omega = \frac{1.6}{\phi}$$

For LRFD, equation F1.1-1a of AISI-NAS S100 applies under the IBC and equation F1.1 in the 1991 LRFD Specifications or equation F1.1-1 in the 1996 Specifications applies under the UBC.

The results are then compared to the design equations in Section C3.4 of AISI-NAS S100 for use under the IBC, and Section C3.4 of the 1986 ASD Specifications, 1991 LRFD Specifications or 1996 Specifications for use under the UBC. The lowest result, from either testing or calculations, will determine the allowable value noted in the evaluation report except as set forth in Section 4.1.3. Where design capacities are derived from testing, the tested value of the lighter thickness will apply to heavier thicknesses up to the point of the next tested thickness. If the calculated result is the lowest value, capacities for heavier thicknesses are permitted to be calculated in accordance with the applicable specification.

4.1.3 Special Conditions: This Either one of these conditions may be applied when a steel deck profile has a modification that is not addressed by the geometry variables listed in Section C3.4 of AISI-NAS S100.

4.1.3.1 High Test Values: In order to report web crippling values that are higher than calculated values, at least three material thicknesses, including the minimum and maximum values, and each support condition (end and interior) in the largest and least bearing widths, shall be tested to develop the spectrum of variables for the deck. When test results exceed the calculated allowable value, the evaluation report will note the test value when the following methodology is applied.

The test results shall be used to develop the nominal strength [resistance] equation. Using the design equations in Section C3.4 of AISI-S100 and the test results, a strength [resistance] modification factor, C₁, will be derived by comparing the test results and AISI-NAS S100 calculated values.

$$R_n = C_1 R_{n,AISI}$$

where:

R_{n,AISI} = nominal web crippling strength [resistance] in accordance with AISI-NAS S100 Section C3.4.

C₁ = strength [resistance] modification factor based on test results.

R_n = nominal web crippling strength [resistance] for the modified profile.

The strength modification factor, C₁, is derived based on a best fit function (linear or higher order) to the percent error of test value and AISI-NAS S100 design equation for each bearing width tested. C₁ is limited to the minimum percent increase from the AISI-NAS S100 design equation when applied to thicknesses not tested. The C₁ factor shall be normalized to the specified yield point, F_y. The value of Ω or φ used to determine the design strength shall be taken from either Section A1.2 A1.2 (b) or Section C3.4 of NAS AISI S100, whichever results in the least design strength.

4.1.3.2 Low Test Values: In order to report interpolated web crippling values when the tested values are less than the calculated values, at least two material thicknesses, including the minimum and maximum values, and each support condition (end and interior) in the largest and least bearing widths, shall be tested to develop the spectrum of variables for the deck. The evaluation report will note the adjusted test value when the following methodology is applied.

The test results shall be used to develop the nominal strength (resistance) equation. Strength (resistance) modification coefficients, C', c'_N, c'_h, will be derived by using a non-linear regression analysis on the test results and AISI S100 calculated values.

$$R_n = C' C_t^2 F_y \sin\theta (1 - C_R (R/t)^{1/2}) (1 + c'_N C_N (N/t)^{1/2}) (1 - c'_h C_h (h/t)^{1/2})$$

where:

N = Bearing length.

C, C_R, C_N, C_h = Coefficients from Table C3.4.1-5.

C', c'_N, c'_h = Modification coefficients.

R_n = nominal web crippling strength [resistance] for the modified profile.

The strength modification coefficients, C', c'_N, c'_h, are derived based on a nonlinear regression analysis to the percent error of test value and AISI S100 design equation for each bearing width tested. C', c'_N, c'_h, are limited to the minimum percent increase from the AISI S100 design equation when applied to thicknesses not tested. The C', c'_N, c'_h, coefficients shall be normalized to the specified yield strength, F_y. The value of Ω or φ used to determine the design strength shall be taken from either Section A1.2 (b) or Section C3.4 of AISI S100, whichever results in the least design strength.

4.2 Diaphragm Testing:

4.2.1 General: For diaphragm constructions of steel deck roof and floor systems that are outside the scope of the diaphragm design calculation methods references in Section 3.3.1, full-scale testing shall be conducted in accordance with AISI S907-08 as modified in Section 4.2 of this criteria.

4.2.2 Test Frame: The diaphragm test assembly shall consist of a test frame on which the elements comprising the web of the diaphragm are to be placed.

PROPOSED REVISIONS TO THE ACCEPTANCE CRITERIA FOR STEEL DECK ROOF AND FLOOR SYSTEMS

~~— The test frame length, a , and depth, b , dimensions shall represent an approximately square zone with the frame consisting of perimeter members and interior support members similar to those intended for the construction being investigated. Also, see additional frame size requirements in Section 4.2.3. Perimeter frame member ends shall be interconnected using angles or other devices sufficient to transfer developed axial forces into the frame supports. Interior members or purlins shall be fabricated with bolted clip angles or such other means as to minimize bending moment transfer at member ends.~~

~~— The test frame layout shall comply with either Figure 1 or Figure 2 for the schematically illustrated test setups shown in the figures. The test frame shall be configured such that the test frame will be attached to supporting devices by means appropriate for reactions.~~

~~— Figure 1 illustrates a pinned frame reaction to an abutment at corner (C) to react the load (P) and the flexural tensile load (Pa/b); and a vertical roller to an abutment at corner (D) to react the flexural compressive load (Pa/b) but permit movement along line (C-D). The frame member (A-B) of Figure 1 shall be laterally supported to prevent out-of-plane displacement of the test specimen but not restrict in-plane displacements.~~

~~— Figure 2 illustrates reaction connection at corner (C) to react the flexural tensile load (Pa/b), with frame member (C-D) extended to a compressive bearing joint at point D to react the load (P), and a compressive bearing joint provided at corner (D) to react the flexural compressive load (Pa/b). The frame member (A-B) of Figure 2 shall be laterally supported to prevent out-of-plane displacement of the test specimen but not to restrict in-plane displacement.~~

4.2.3 Full Frame Test Assembly: The plan dimensions of the test frame shall be such that five or more steel deck panels are required to cover the test frame depth, b , as shown in Figures ~~4 and 2 and 3 of AISI S907~~. The steel deck panels are allowed to either span between Lines AB and CD as shown in Figures ~~4 and 2 and 3 of AISI S907~~ or span between Lines AC and BD. ~~The test assembly shall not be less than 12 feet (3.6 m) in either length or width; the test diaphragm shall be assembled using the steel deck panels and spans, as well as the type, size and spacing of fasteners of steel deck panel to steel deck panel and steel deck panel to framing connections, to be evaluated. Where edge transfer angles or profiled end closure elements are used for shear transfer, they shall be included in the test assembly. If steel deck panel end lap splices are used in the field assembly, an end lap splice shall be placed on at least one intermediate bearing. The physical properties and base-metal thickness of the steel deck panels used in the diaphragm tests must be verified as required by Section 4.4.1. Welds of the test assembly shall comply with Section 4.4.4. The fasteners used in the test specimens shall comply with Sections 4.4.5 and 4.4.6, as applicable. It shall be permitted to fasten the steel deck panels to the framing parallel to the flutes at a spacing that assures the failure mechanism of the specimen occurs in the field of the specimen. The spacing of fasteners parallel to the flutes of the steel deck panels at collectors or the diaphragm boundary used in building design shall be based on the shear strength of the connection of the steel deck panel to the framing member.~~

~~— For tests of steel deck panels with concrete fill, the concrete shall be placed on the steel deck panels with the concrete verified as required by Section 4.4.2 or 4.4.3, as applicable.~~

4.2.4 Steel Deck Panel Finish: For steel deck panels available with more than one finish on the steel, the following guidelines are applicable;

4.2.4.1 Test results conducted on steel deck panels with concrete fill with one finish are permitted to be extended to decks with alternate finishes within the types noted in Sections 3.1.1.2 through 3.1.1.4.

4.2.4.2 Test results conducted on steel deck panels without concrete fill with any one finish of the types noted in Sections 3.1.1.2 through 3.1.1.4 are permitted to be extended to the finish types noted in Sections 3.1.1.2 through 3.1.1.4.

4.2.5 Test Procedure:

4.2.5.1 General: ~~The tests are permitted to be conducted with the test assembly in either a vertical or horizontal configuration. The test setup for test frame layouts complying with Figure 1 shall be as shown in either Figure 3 or Figure 4.~~

~~The test setup for test frame layouts complying with Figure 2 shall be as shown in either Figure 3, Figure 5 or Figure 6. An alternative to the location of instruments to measure the test frame movement is shown in Figures 4, 5 and 6.~~

~~The test loads shall be applied to the test frame of the specimen at the location shown in the figures. Application of the test loads to the frame with the loads parallel to, and as close as practical to the shear center of the test assembly, with the shear center measured perpendicular to the plane of the steel deck panels, will minimize out-of-plane movement of the test specimen.~~

4.2.5.2 Bare Frame: ~~The test frame without steel deck panels shall be subjected to the diaphragm load test procedure to determine the strength and stiffness of the bare frame as described for the tests of the full frame test assembly. Frame member AB in Figures 1 and 2 shall be loaded to support at least the dead load on the member that will be exerted when testing the full frame assembly. See Section 4.2.6 for additional information regarding the adjustment to diaphragm shear strength and stiffness due to the bare test frame strength and stiffness.~~

4.2.5.3 Full Frame Test Assembly: ~~The loading sequence up to the maximum applied load, P_u , shall provide at least ten evenly spaced sets of deflection readings prior to reaching P_u , and the rate of loading shall be such that P_u is achieved in not less than 10 minutes. The rate of load application shall permit load and deflection readings to be recorded. Loads shall be applied with hydraulic jacks that have been previously calibrated, or by other suitable types of loading apparatus. The weight of the specimen and loading apparatus shall be accounted for, if it is anticipated that the weights will affect the results. Deflections shall be measured with dial gages or other suitable devices to establish an adequate load deflection curve. Deflections shall be measured to the nearest 0.01 inch (0.2 mm). Load measuring devices shall be accurate to within ± 2~~

PROPOSED REVISIONS TO THE ACCEPTANCE CRITERIA FOR STEEL DECK ROOF AND FLOOR SYSTEMS

percent. At load levels of approximately one quarter and one half of the estimated maximum load, the load shall be removed and the recovery of the diaphragm recorded after five minutes.

4.2.6 Analysis of Diaphragm Tests: The nominal diaphragm web shear strength, S_u , as the shear load per unit length across the full frame test assembly at the maximum load, shall be calculated using Eq 1:

$$S_u = \frac{P_u}{b} \left(\frac{1000 P_u}{b}, N/m \right) \quad (\text{Eq. 1})$$

where:

P_u = P_{max} if $\frac{P'_t}{P_{max}} > 2$ percent, pounds (N).

P_u = P_{max} if $\frac{P'_t}{P_{max}} \leq 2$ percent, pounds (N).

P_{max} = maximum applied load to the full frame test assembly, pounds (N).

P'_t = Load on the bare frame test at the deflection on the full frame test assembly loaded to P_{max} pounds (N).

b = diaphragm depth, as indicated in Figures 1 through 6, measured to the centerline of the test frame framing members, feet (m).

To determine the diaphragm shear stiffness, G' , for the full frame test assembly, the load net deflection curve shall be plotted for each load, P , against all the corresponding net deflections, Δ_{nt} . The net deflection at any load level, Δ_{nt} , for deflections measured at diagonals as shown for the method in Figure 3 shall be calculated using Eq 2:

$$\Delta_{nt} = \frac{(|\Delta_1| + |\Delta_2|) b}{2\sqrt{a^2 + b^2}} \quad (\text{Eq. 2})$$

where:

a = diaphragm span, as indicated in Figures 1 through 6, measured to the centerline of the test frame framing members, feet (m).

The net deflection at any level, Δ_{nt} , for deflections measured at corners as shown in Figures 4 through 6 shall be calculated using Eq 3:

$$\Delta_{nt} = \Delta_3 - \left[\Delta_4 + a/b (\Delta_2 + \Delta_4) \right] \quad (\text{Eq. 3})$$

where:

Δ_i = recorded deflections at gage locations described in Figures 4 through 6, inches (mm).

When Figure 6 is used for the diaphragm tests, the values of Δ_{nt} shall be adjusted as described in Figure 6.

The diaphragm shear stiffness, G' , pounds/inch (N/mm) shall be calculated as the slope of the full frame test assembly load net deflection curve between the origin and the test load equal to 40 percent of the maximum applied load ($P = 0.40 P_u$) using Eq 4:

$$G' = \frac{P}{\Delta_{nt}} \times \left(\frac{a}{b} \right) \quad (\text{Eq. 4})$$

where:

$P = 0.4 P_{max}$ pounds (N).

P_{max} = maximum applied load to the full frame test assembly.

Δ_{nt} = Net deflection at $0.4 P_{max}$ [inch (mm)].

If the load, P_t , on the bare frame test load net deflection curve at a deflection equal to the deflection of the full frame test assembly at $0.4 P_{max}$ exceeds 2 percent of $0.4 P_{max}$, then a value of $0.4 P_{max}$ P_t shall be substituted for P in the above equation to determine the diaphragm shear stiffness, G' .

The flexibility factor of the diaphragm web, F , can be calculated as the reciprocal of the diaphragm shear stiffness multiplied by 10^6 expressed in microinches (μm) of deflection per foot (m) of diaphragm span with a shear load of 1 lbf per foot (N/m).

4.2.7 Number of Diaphragm Tests: To determine analytical methods for predicting diaphragm strength and stiffness as functions of the steel deck panel geometry, fastener arrangement, fastener types, and diaphragm details, a minimum of three

PROPOSED REVISIONS TO THE ACCEPTANCE CRITERIA FOR STEEL DECK ROOF AND FLOOR SYSTEMS

tests of a given configuration are required. A configuration consists of a steel deck profile, sidelap connection type and specific type and pattern of fasteners used to attach the steel deck panels to supports that are perpendicular to the flutes of the steel deck panels. Each of the three tests within a configuration shall be diverse in arrangement involving differing steel deck panel thicknesses, differing steel deck panel span lengths, and differing sidelap fastener spacing within the common limits of configurations under evaluation.

~~— The diaphragm shear stiffness, G' , varies with the span length of the steel deck panels. Straight-line interpolation of values of G' with respect to steel deck panel span length shall be permitted between values of G' of tested diaphragms with steel deck spans greater and less than the steel deck panel span of the diaphragm under consideration.~~

4.2.8 Conditions of Acceptance: ~~Section 12 of AISI S907 is to be modified to limit the analysis of data to only represent the range of deck assemblies tested. The analysis shall not cover (1) deck thicknesses less than or greater than what was tested; (2) panel steel grades less than or greater than what was tested; (3) panels-to-frame fastener patterns less than or greater than tested; (4) side lap fastener spacing less than or greater than tested. The diaphragm test results shall be recorded and reduced by safety factors, Ω_d , or resistance factors, ϕ_d , described in Section D5 of AISI-NAS used under the IBC, and Section D5 of the 1986 ASD Specifications or 1991 LRFD Specifications or 1996 Specifications under the UBC, to obtain the allowable shear loads for allowable stress design (ASD) and design loads for load and resistance factor design (LRFD). The reduced shear loads and deflections shall be compared with the calculated procedures using equations in the diaphragm design references. Equations are permitted to be modified to achieve a correlation coefficient between the equations and test data of 0.95 or better. Unless only one configuration is available, for each deck type, at least two different configurations (i.e., fastener spacings, deck thickness) shall be tested to provide an adequate data base for reconciling variations with the design equations.~~

~~— For diaphragms consisting of steel deck panels with power actuated or screw fasteners attaching the panels to steel supports, the results of the test assembly tests shall be adjusted when the steel substrate thickness or strength of the tested conditions varies from the substrate thickness and strength to be specified in the evaluation report. The adjustments shall be based on results of tests of fasteners and connections with fasteners with proper consideration given to fastener application limits and similarity of failure modes. Tension and shear tests of fasteners shall be conducted in accordance with AISI TS-4-02 and as indicated in AC118. Shear and tension tests of connections shall be conducted in accordance with AISI TS-05-02 and as indicated in AC118.~~

~~As stated in Section F1.1(c) of AISI S100, if the yield strength and the thickness of the steel from which the deck panel test sections are formed are greater than the specified values, the test results shall be reduced. The adjustment factor R_s shall be the ratio of the specified yield strength and thickness over the actual yield strength and thickness, respectively determined as follows:~~

$$R_s \equiv \frac{F_{u(\text{specified})}}{F_{u(\text{actual})}} \times \frac{t_{(\text{specified})}}{t_{(\text{actual})}} \leq 1.0$$

4.3 Vertical Loads on Composite Slabs: As required by Section 3.4.1, tests to evaluate shear bond performance shall be conducted in accordance with Chapter 3 of the ANSI/ASCE 3-91 standard. At least two full-scale specimens of each steel deck panel type shall be evaluated. In addition, flexural tests in accordance with Section 3.2.3.2 of the standard are required for steel deck panels more than 3 inches (76 mm) deep or formed from low-ductility steels, having a ratio of F_u/F_y less than 1.08, using three identical flexural strength test specimens. The test results shall be recorded and evaluated in accordance with Section 3.2.4 of the standard. Data shall be analyzed in accordance with Section 3.4.1 of this criteria. Other test evaluation methods require prior concurrence of the ICC-ES staff.

4.4 Test Specimens:

4.4.1 Steel: Steel deck panels used in the web crippling, diaphragm and composite slab tests shall be evaluated by material property tests to determine the tensile strength, yield strength, and elongation in accordance with the appropriate standard for the steel grade. In addition, the base metal thickness shall be determined. Test results shall be based on the evaluation of at least three specimens in each thickness. The specimens shall be selected from different panels on the test specimen.

4.4.2 Structural Concrete:

4.4.2.1 General: To obtain desired concrete compressive strengths, the mix of the concrete used in the diaphragm and composite slab tests should follow recommendations for proportioning in the Design and Control of Concrete Mixtures; ACI 211.1 or ACI 211.2; and Chapter 19 of the ~~UBC~~ or IBC. Test cylinders of the concrete used in the diaphragm and composite slab tests shall be prepared and tested in accordance with ASTM C 31 and ASTM C 39.

4.4.2.2 Structural Normal-weight Concrete: Normal-weight aggregate in the concrete shall comply with ASTM C 33. Aggregate description shall include the rock and mineral components, shape, hardness, maximum size and grading specification. Concrete cylinders shall be field-cured in accordance with ASTM C 31 for 28 days, with a five-day allowable minus tolerance. Two tests of two cylinders shall be performed and the average compressive strength reported during a 24-

PROPOSED REVISIONS TO THE ACCEPTANCE CRITERIA FOR STEEL DECK ROOF AND FLOOR SYSTEMS

hour period immediately preceding and following any diaphragm or composite slab test series. Two cylinders constitute one test. The average of two tests, or four cylinders total, establishes the compressive strength of the testing medium.

For diaphragm or composite slab tests conducted with concrete aged 90 days or more, the concrete compressive strength shall be the average of three test cylinders aged a minimum of 90 days and tested in accordance with ASTM C 39.

4.4.2.3 Structural Lightweight Concrete: Lightweight concrete shall comply with the same requirements as normal-weight concrete in Section 4.4.2.2, except for the aggregate specification. Lightweight aggregate shall be identified by the generic or trade name, shape, size, maximum size, grading specification and compliance with the requirements in ASTM C 330.

4.4.3 Insulating Concrete:

4.4.3.1 General: The compressive strength of the insulating concrete used in the diaphragm tests shall be determined in accordance with ASTM C 495. The concrete cylinders shall be field-cured. Two tests of two cylinders shall be performed and the average compressive strength reported during a 24-hour period immediately preceding and following any diaphragm test series. Two cylinders constitute one test. The average of two tests, four cylinders total, establishes the compressive strength of the testing medium.

4.4.3.2 Insulating Concrete with Aggregates: In addition to the compressive strength, the density of the insulating concrete used in the diaphragm tests must be determined in accordance with ASTM C 332, and the aggregate shall be described by group, rock and mineral components, expansion process, shape, maximum size, grading specification and unit weight.

4.4.3.3 Insulating Cellular Concrete: In addition to determining the compressive strength of the cellular concrete of the diaphragm test specimens, the density of the cellular concrete shall be determined, and the cellular concrete must be applied to the steel deck panels in accordance with the instructions of the manufacturer of the foaming agents, with the cellular concrete mix design and placement included in the test report.

4.4.4 Welding: Arc-spot and seam welds of the diaphragm test specimens shall be performed in accordance with Section E2 of AISI-NAS S100 ~~for use under the IBC; or Section E2 of the 1986 ASD Specifications, 1991 LRFD Specifications or 1996 Specifications for use under the UBC.~~ Welding process, filler metal weld size, fusion diameter, electrode amperage setting and flash time for welds used in tests shall be reported in the ICC-ES report. ~~Location~~ location and any weld defects such as cracks shall be reported. The fusion diameter is permitted to be determined from the welder's qualification tests.

4.4.5 Mechanical Fasteners: Mechanical fasteners of the diaphragm test specimens shall be installed in accordance with the fastener manufacturer's recommendations. A detailed description of fasteners shall be provided, including material specification, length, diameter, thread pitch, head diameter, head shape and penetration distance into or through the substrate steel. ~~When full scale diaphragm testing is required, fastener/connection tests are to be run on samples from each box of fasteners used in the diaphragm test. If mechanical fasteners are used that have an ICC-ES report, the full frame assembly test shall be reduced by the ratio of the specified fastener values in the ICC-ES report and the values determined in the fastener tests. If mechanical fasteners used do not have an ICC-ES report, the ICC-ES diaphragm report will report the fastener values as a minimum requirement. Fasteners from the lot of fasteners used in the diaphragm test shall be tested in accordance with Section 3.1.4.2. If the fasteners are recognized in an ICC-ES evaluation report, the results of the diaphragm tests shall be reduced by a ratio of the fastener strengths in the ICC-ES evaluation report to the fastener strengths determined in accordance with this section. If the proprietary fasteners do not have an ICC-ES evaluation report, the target values in the fastener manufacturer's quality documentation shall be used.~~ Additional tests with stainless steel fasteners shall be required, when such fasteners are required as set forth in Section 6.4. The spacing of fasteners relative to the edge and ends of the steel deck panels of the diaphragm test specimens shall be representative of end-use construction.

4.4.6 Steel Deck Panel Side Seam Fasteners: Button punch or clinch fastener connections used in the diaphragm test specimens require detailed descriptions.

5.0 QUALITY CONTROL

5.1 Steel Deck Panels:

5.1.1 General: For all steel deck panels, quality control documentation, complying with the ICC-ES Acceptance Criteria for Quality Documentation (AC10), shall be submitted. The factory-welded, cellular steel decks shall be manufactured under an approved quality control program with inspections conducted by an inspection agency accredited by the International Accreditation Service (IAS) or otherwise acceptable to ICC-ES. Third-party follow-up inspections are not required under this acceptance criteria for fluted steel deck panels.

5.1.2 Cellular Decks with Resistance Welds: This section applies to cellular decks, where individual sheets are connected by resistance welds. Typical welded sheets shall be evaluated using the tension shear test in Sections 11.1 and 11.2 of UL 209 and a peel test in accordance with Sections 12.1 and 12.2 of the UL Standard.

5.1.3 All Steel Deck Panels: The steel deck panel quality control program shall include the following:

5.1.3.1 Verification of incoming steel-coil material in the form of mill certificates, service center certificates, independent laboratory tests or in-house testing with calibrated test equipment. Tests shall verify the following, if the steel does not conform to one of the steel specifications noted in Section A2.1 of AISI-NAS S100 ~~or Section A3.1 of the 1986 ASD Specifications, 1991 LRFD Specifications or 1996 Specifications:~~ steel base metal thickness, yield strength, tensile strength,

PROPOSED REVISIONS TO THE ACCEPTANCE CRITERIA FOR STEEL DECK ROOF AND FLOOR SYSTEMS

galvanized coating weight and ductility. Ductility compliance shall be determined in accordance with Section A2.3 of AISI-NAS S100 or Section A3.3 of the 1986 ASD Specifications, 1991 LRFD Specifications or 1996 Specifications.

5.1.3.2 Periodic testing for base metal thickness is permitted to be conducted in-house or by an independent laboratory. Periodic testing consists of testing one out of every 120 pieces. Periodic testing of coated material is permitted, provided complete details covering the method of thickness determination are included in the quality control manual.

5.1.3.3 Records shall be kept of all mill certificates, service center certificates, independent laboratory tests and in-house tests for a minimum of two years.

5.1.3.4 Tests shall be conducted in accordance with the following:

Yield strength—ASTM A 370

Tensile strength—ASTM A 370

Galvanized coating (hot-dip process)—ASTM A 653, Section 8.1.4

Galvanized coating (electrolytic)—ASTM A 591, Section 6

Additionally, ductility compliance shall be determined in accordance with Section A2.3 of AISI-NAS S100, or Section A3.3 of the 1986 ASD Specifications, 1991 LRFD Specifications or 1996 Specifications. Minimum acceptance criteria for each test shall be specified in the quality documentation.

5.1.3.5 Verification of compliance with requirements in Part 2 of ANSI/SDI-NC1.0 or Part 2 of ANSI/SDI-RD1.0 as applicable.

5.2 Insulating Concrete with Aggregates: Quality documentation for the aggregates of insulating concrete with aggregates shall be submitted. The quality documentation shall comply with AC10.

5.3 Cellular Concrete: See AC272 for the quality control requirements for the cellular concrete constituents.

5.4 ~~Power-actuated Proprietary Fasteners:~~ ~~See AC70 for the quality control requirements for the power-actuated fasteners.~~ Quality documentation complying with AC10 shall be submitted, unless the fasteners are recognized in a separate ICC-ES evaluation report.

5.5 Tapping Generic Screws: See AC118 for the quality ~~control~~ documentation requirements for the ~~tapping generic~~ screws.

5.6 ~~Quality documentation in accordance with AC10 must be provided for proprietary fasteners, when the manufacturer of such fasteners is not an ICC-ES report holder.~~

6.0 EVALUATION REPORT RECOGNITION

6.1 The evaluation report on the steel deck panels shall include the information specified in Section 3.2.1 of this criteria and web crippling values as addressed in Section 3.2.2.

6.2 Evaluation reports that include recognition of the steel deck panels for use in steel deck diaphragms shall include a table similar to Table 2 of this criteria and including, within a Diaphragm Design Considerations section of the report, requirements that the diaphragm design take into account the following:

- Diaphragm classification (flexible or rigid) shall comply with ~~Section 1630.6 of the UBC or~~ Section 1602 of the IBC; the diaphragm deflection (Δ) shall be calculated using the equations noted in the Diaphragm Flexibility Limitations Table (Table No. XXX).

- Diaphragm flexibility limitations shall comply with the table.

- Diaphragm deflection limits shall comply with ~~Section 1633.2.9 of the UBC or~~ Sections 12.10.1 and 12.12.2 of ASCE 7.

- Horizontal shears must be distributed in accordance with ~~Sections 1630.6 and 1630.7 of the UBC or~~ Section 12.8.4 of ASCE 7.

6.3 Evaluation reports that include fire-resistance-rated assemblies consisting of normal-weight or structural lightweight concrete fill and a restrained assembly rating shall include a statement that interior spans of the steel deck panels may be considered restrained. The evaluation reports shall contain a statement that Appendix X3 of ASTM E 119 or ACI 216.1 may be referenced as guidance on other possible restraint conditions at both exterior spans and discontinuities within fire-resistance-rated constructions, subject to the approval of the code official.

6.4 Evaluation reports including roof systems with steel deck panels directly exposed to the exterior, such as a roof covering, shall include a statement that the fasteners used to attach the panels shall be stainless steel or galvanized steel when covered with a stainless steel sealing cap, corrosion-resistant paint, or sealant.

6.5 Evaluation reports including roof systems with steel deck panels directly exposed to the exterior, such as a roof covering, shall include a statement that welds shall not be permitted to attach steel deck panels in these locations.

6.6 The following statement shall be added to all evaluation reports: "Connections between steel decks and support members are prohibited in protective zones of structures designed for seismic." ■

**PROPOSED REVISIONS TO THE ACCEPTANCE CRITERIA
FOR STEEL DECK ROOF AND FLOOR SYSTEMS**

TABLE 1—CROSS REFERENCE OF STANDARDS EDITIONS

STANDARD	1997 UBC	2006 2009 IBC
ASTM A 370	1995	1997a
ASTM A 591	1989 (1994)	1989 (1994)
ASTM A 653	1995	2004a 2007
ASTM A 924	1995	2004 2007
ASTM C 31	1991	2003a 2006
ASTM C 33	1993	2003
ASTM C 39	1993a	2003
ASTM C 127	1988	1988
ASTM C 330	1989	2004 2005
ASTM C 332	1983	1987 (1991)
ASTM C 495	1991a	1991a
ASTM C 796	1997	1997
ASTM C 869	1994	1991
ASTM E 72	1995	2002
ASTM E 119	UBC Std. 7-1	2000a 2007

TABLE 2—DIAPHRAGM FLEXIBILITY LIMITATIONS TABLE^{1,2,3,4,5}

F	MAXIMUM DIAPHRAGM SPAN FOR MASONRY OR CONCRETE WALLS (feet)	DIAPHRAGM SPAN-DEPTH LIMITATION			
		Rotation Not Considered in Diaphragm		Rotation Considered in Diaphragm	
		Masonry or Concrete Walls	Flexible Walls	Masonry or Concrete Walls	Flexible Walls
More than 150	Not used	Not used	2:1	Not used	1 ¹ / ₂ :1
70-150	200	2:1 or as required for deflection	3:1	Not used	2:1
10-70	400	2 ¹ / ₂ :1 or as required for deflection	4:1	As required for deflection	2 ¹ / ₂ :1
1-10	No limitation	3:1 or as required for deflection	5:1	As required for deflection	3:1
Less than 1	No limitation	As required for deflection	No limitation	As required for deflection	3 ¹ / ₂ :1

For SI: 1 inch = 25.4 mm, 1 foot = 304.8 mm, 1 plf = 14.594 N/m, 1 psi = 6894 Pa.

¹Diaphragms are to be investigated regarding their flexibility and recommended span-depth limitations.

²Diaphragms supporting masonry or concrete walls are to have their deflections limited to the following amount:

$$\Delta_{wall} = \frac{H^2 f_c}{0.01 Et}$$

where:

- H = Unsupported height of wall in feet.
- t = Thickness of wall in inches.
- E = Modulus of elasticity of wall material for deflection determination in pounds per square inch.
- fc = Allowable compression strength of wall material in flexure in pounds per square inch. For concrete, fc = 0.45 f_c. For masonry, fc = Fb = 0.33 f_m.

³The total deflection Δ of the diaphragm may be computed from the equation: Δ = Δ_f + Δ_w

where:

- Δ_f = Flexural deflection of the diaphragm determined in the same manner as the deflection of beams
- Δ_w = The web deflection may be determined by the equation:

$$\Delta_w = \frac{q_{ave} L F}{10^6}$$

**PROPOSED REVISIONS TO THE ACCEPTANCE CRITERIA
FOR STEEL DECK ROOF AND FLOOR SYSTEMS**

where:

- L = Distance in feet between vertical resisting element (such as shear wall) and the point to which the deflection is to be determined.
- q_{ave} = Average shear in diaphragm in pounds per foot over length L .
- F = Flexibility factor: The average micro inches (μm) a diaphragm web will deflect in a span of 1 foot (m) under a shear of 1 pound per foot (N/m).

⁴When applying these limitations to cantilevered diaphragms, the allowable span-depth ratio will be half that shown.

⁵Diaphragm classification (flexible or rigid) and deflection limits shall comply with the Diaphragm Design Considerations section of the evaluation report.

PROPOSED REVISIONS TO THE ACCEPTANCE CRITERIA
FOR STEEL DECK ROOF AND FLOOR SYSTEMS

TABLE 3
DDM03 METHOD OF DIAPHRAGM DESIGN

DIAPHRAGM ASSEMBLY DESCRIPTION		DIAPHRAGM VALUES ¹										UPLIFT RESISTANCE ² (BY OTHERS SUCH AS ENGINEER OF RECORD AND REPORT HOLDERS ON SCREWS AND POWER-DRIVEN FASTENERS)				
		AISI S905 ⁴				AISI S907 ³			Calculate DDM03 ³			Calculate Allowable Uplift Per AISI S100		Test		
		Q _f	Q _s	S _f	S _s	S _n	G'	F	S _n	G'	F	Weld tension	Screws			Connection per AISI S905 ⁴
													Pullout P _{net}	Pullover P _{nov}	Fastener strength P _{ts} per AISI S904 ⁴	
Standard decks welded to supports	Welded side seam								X	X	X	X				
	Generic screws or button punch on side seam								X	X	X					
	Proprietary screws on side seam		X		X				X	X	X					
	Crimps or etc. on side seam		X		X	X	X	X								
Standard decks w/ generic screws to supports	Welded side seam								X	X	X		X	X	X	X
	Generic screws or button punch on side seam								X	X	X					
	Proprietary screws on side seam		X		X				X	X	X					
	Crimps or etc. on side seam		X		X	X	X	X	X	X	X					
Standard decks w/ shot pins power-actuated fasteners to supports	Shot pins Power-actuated fasteners to support	X		X					X	X	X					X
	Welded side seam								X	X	X					
	Generic screws or button punch on side seam								X	X	X					
	Proprietary screws on side seam		X		X				X	X	X					
	Crimps or etc. on side seam		X		X	X	X	X	X	X	X					
Standard decks w/ proprietary screws to supports	Proprietary screws to supports	X		X					X	X	X		X	X	X	
	Welded side seam								X	X	X					
	Generic screws or button punch on side seam								X	X	X					
	Proprietary screws on side seam		X		X				X	X	X					
	Crimps or etc. on side seam		X		X	X	X	X	X	X	X					
Nonstandard decks w/ any attachment to support and any attachment at side seams						X	X	X				As applicable				

¹Must Shall be reported.

²May be reported.

³Must Shall be submitted by deck manufacturer

⁴May be qualified in conjunction with deck evaluation, or in a separate evaluation report.

PROPOSED REVISIONS TO THE ACCEPTANCE CRITERIA
FOR STEEL DECK ROOF AND FLOOR SYSTEMS

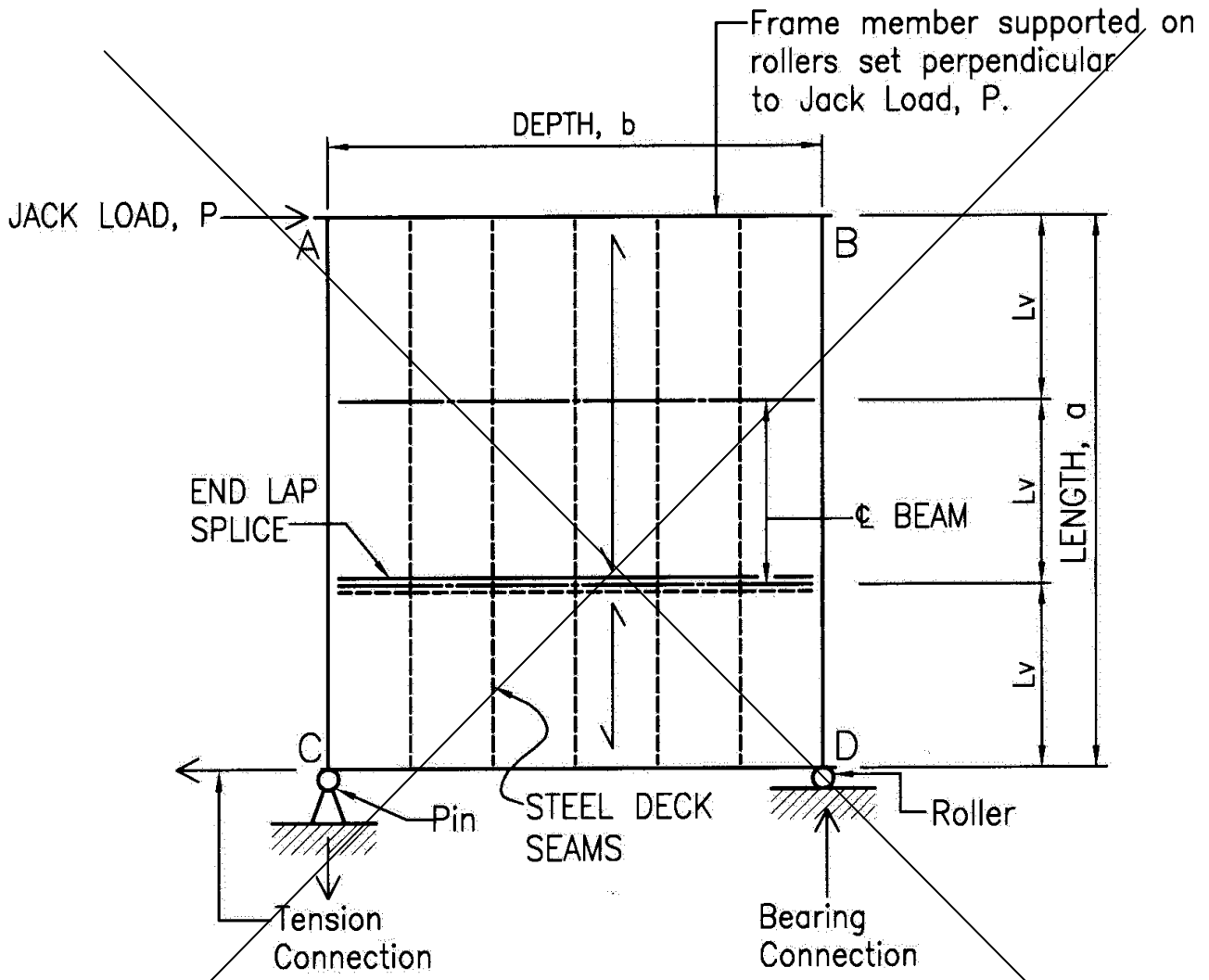

FIGURE 1—TEST FRAME LAYOUT 1

PROPOSED REVISIONS TO THE ACCEPTANCE CRITERIA
FOR STEEL DECK ROOF AND FLOOR SYSTEMS

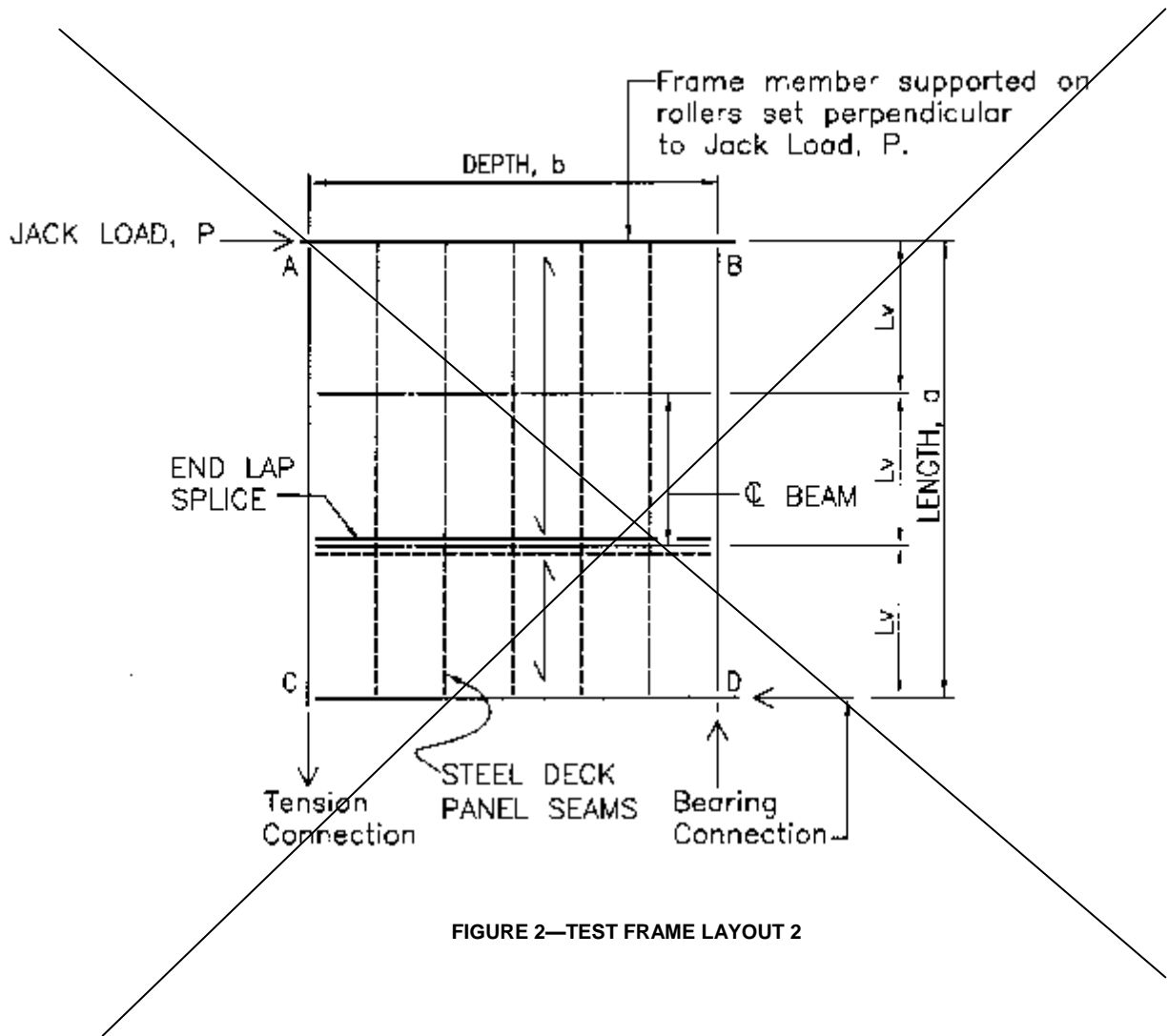

FIGURE 2—TEST FRAME LAYOUT 2

**PROPOSED REVISIONS TO THE ACCEPTANCE CRITERIA
FOR STEEL DECK ROOF AND FLOOR SYSTEMS**

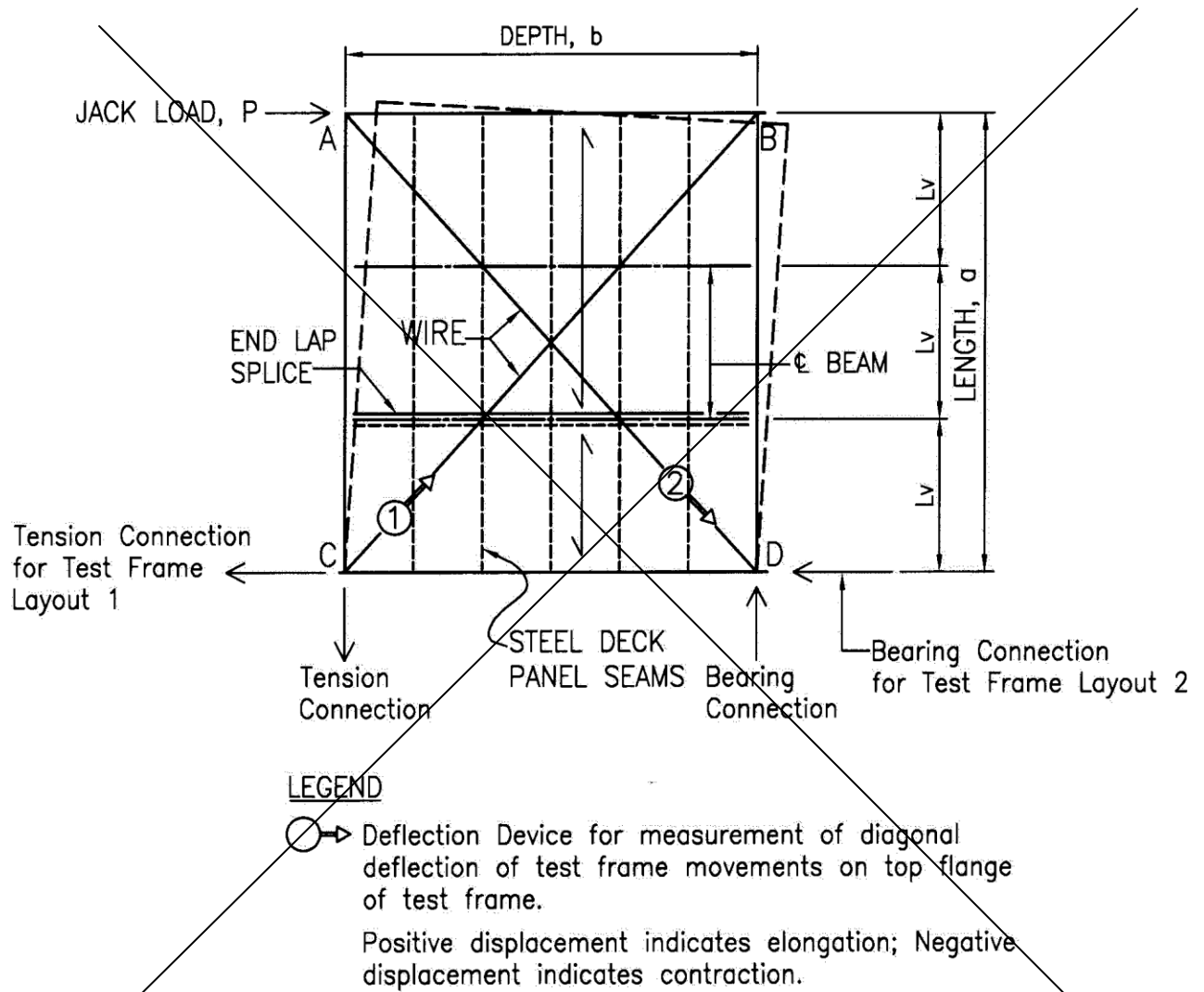
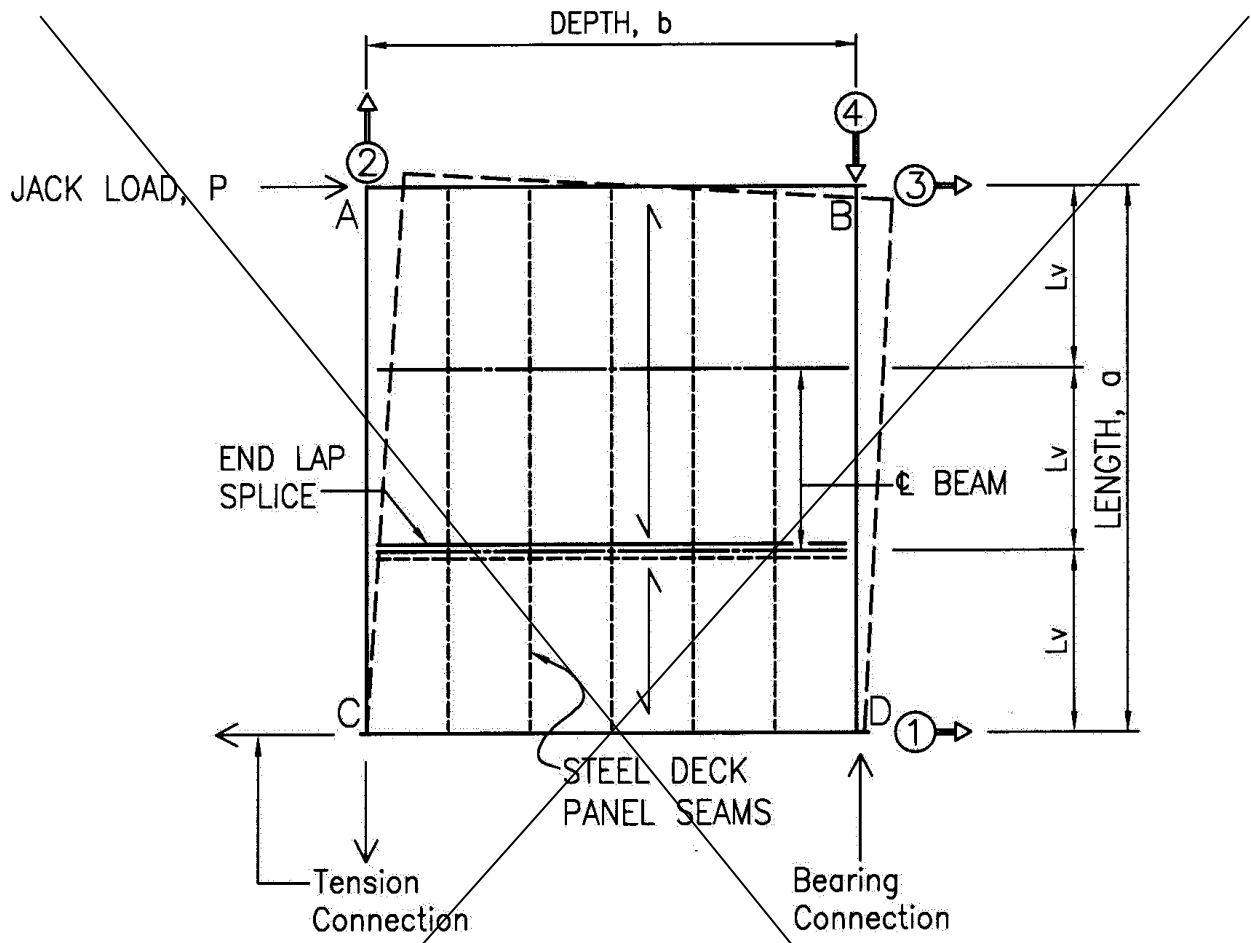

FIGURE 3—DEFLECTION DEVICE SCHEME 1 FOR USE WITH FIGURES 1 OR 2

PROPOSED REVISIONS TO THE ACCEPTANCE CRITERIA
FOR STEEL DECK ROOF AND FLOOR SYSTEMS



LEGEND



Deflection Device mounted on the ground at frame corners to the center height of the test frame web or to the top of test frame members.

Arrow indicates positive direction measured to test frame movements.

Deflection measurements shall be taken at web center height of test framing members.

FIGURE 4—ALTERNATE DEFLECTION DEVICE SCHEME 2 FOR USE WITH FIGURE 1

PROPOSED REVISIONS TO THE ACCEPTANCE CRITERIA
FOR STEEL DECK ROOF AND FLOOR SYSTEMS

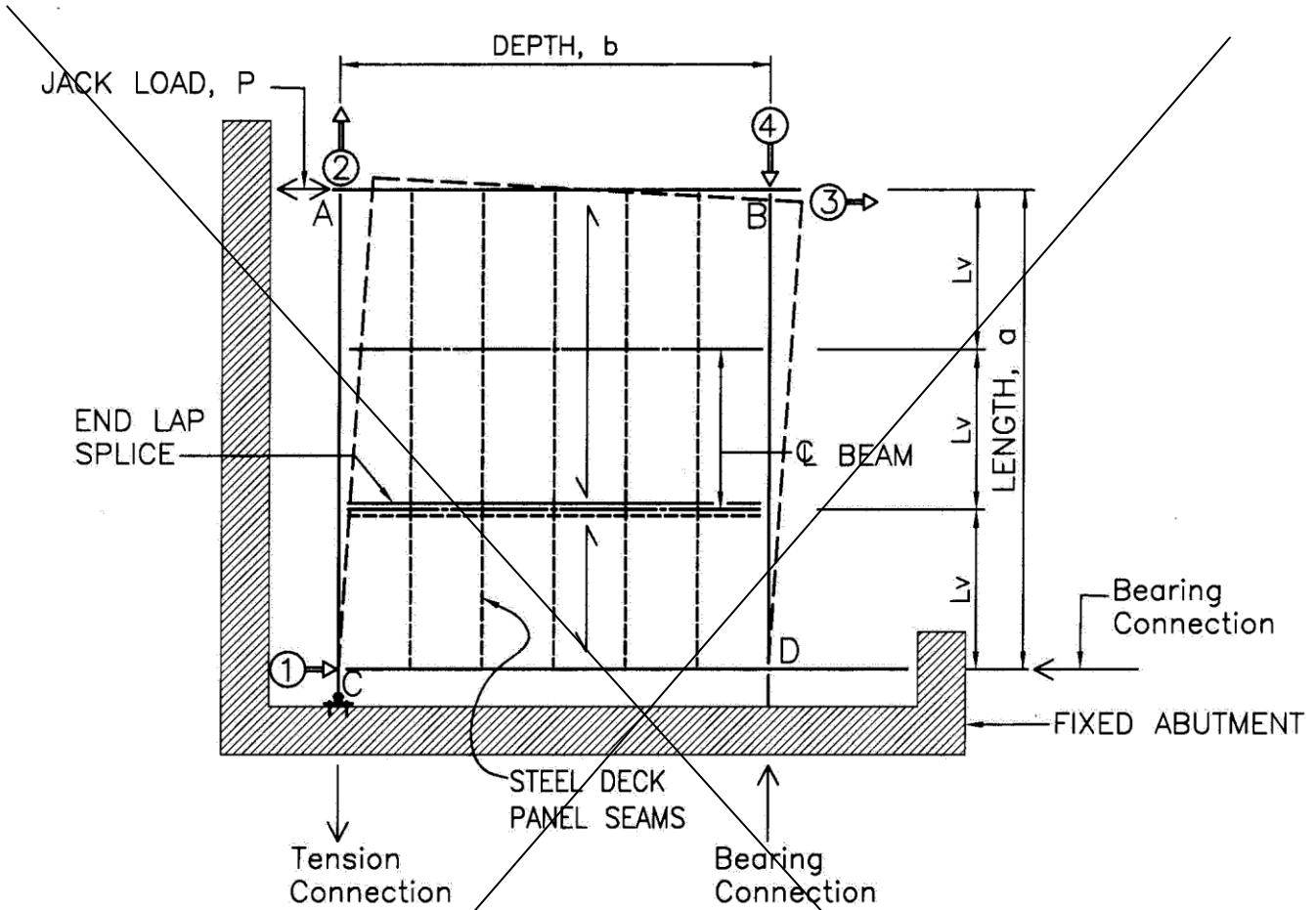

LEGEND

- ➔ Deflection Device mounted on the ground at frame corners to the center height of the test frame web or to the top of test frame members.
- Arrow indicates positive direction measured to test frame movements.
- Deflection measurements shall be taken at web center height of test framing members.

FIGURE 5—ALTERNATE DEFLECTION DEVICE SCHEME 3 FOR USE WITH FIGURE 2

PROPOSED REVISIONS TO THE ACCEPTANCE CRITERIA
FOR STEEL DECK ROOF AND FLOOR SYSTEMS

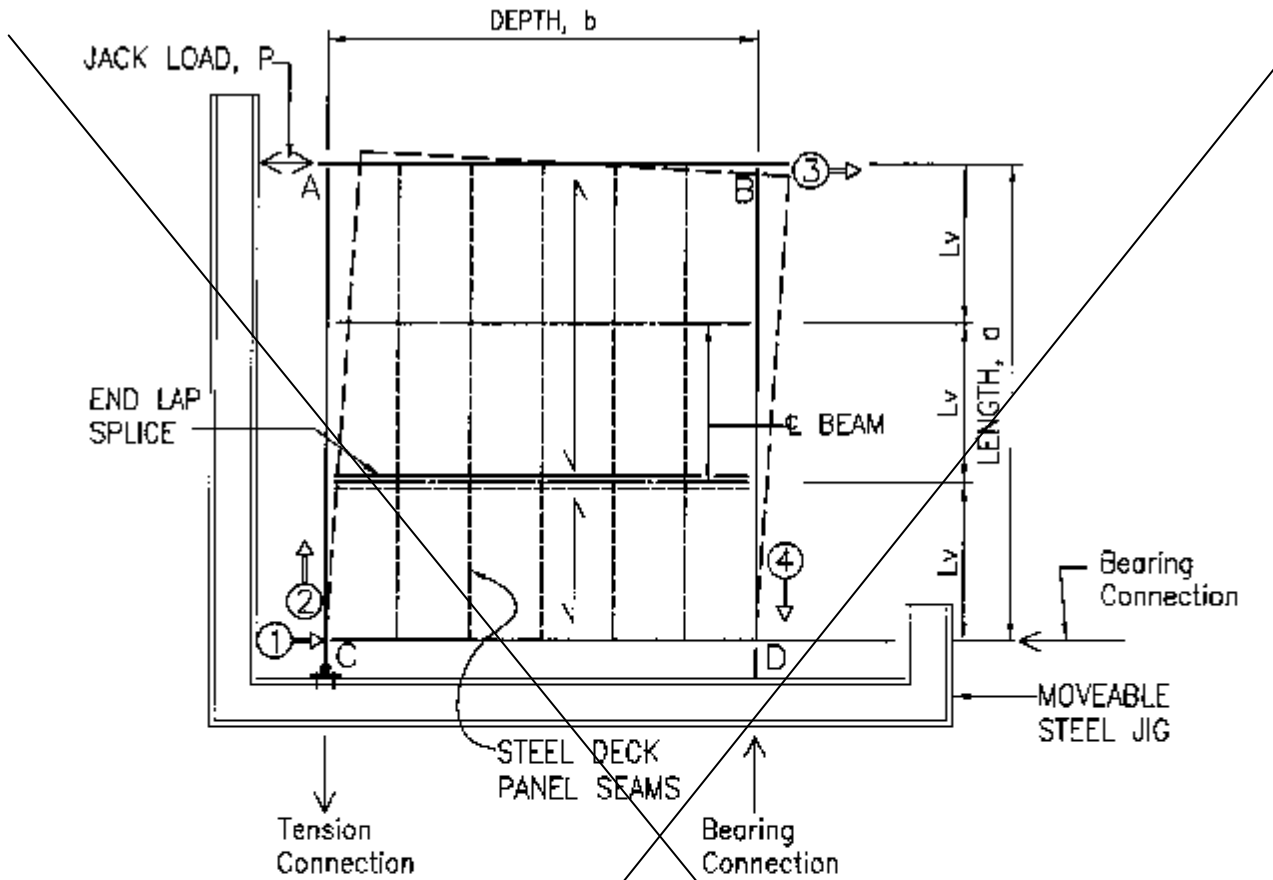

LEGEND

○ → Deflection Device mounted on the ground at frame corners. Arrow indicates positive direction of measured to test frame movements.

Deflection measurements shall be taken at web center height or to the top of test frame members.

For Deflection Devices 2 and 4, if web mounted deflection measurement shall be offset from the web of test framing members and offset from test frame corners to accommodate the framing connections at corners. The sum of the recorded deflections at Deflection Devices 2 & 4 at a load of $0.4P_u$ shall not exceed 0.5 inches.

If the combined effect of calculated axial deformation of members AC & BD $\approx \left[\frac{Pd^2}{2bE_s} \left(\frac{1}{\text{AREA}_{AC}} + \frac{1}{\text{AREA}_{BD}} \right) \right]$ exceed 5% of net diaphragm deflection, Δ_n , the above combined effect shall be added to $(\Delta_2 + \Delta_4)$ term in equation A3 to calculate Δ_n .

FIGURE 6—ALTERNATE DEFLECTION DEVICE SCHEME 4 FOR USE WITH FIGURE 2