



CSI: DIVISION: 03 00 00—CONCRETE
Section: 03 15 19—Cast-In Concrete Anchors
Section: 03 16 00—Concrete Anchors

Product Certification System:

The ICC-ES product-certification system includes evaluating reports of tests of standard manufactured product, prepared by accredited testing laboratories and provided by the listee, to verify compliance with applicable codes and standards. The system also involves factory inspections, and assessment and surveillance of the listee's quality system.

Product: Wood-Knocker® II+ Concrete Inserts and Bang-It®+ Concrete Inserts for Steel Deck in Cracked and Uncracked Concrete

Listee: DEWALT

Compliance with the following standards:

- Annex D, Anchorage of CSA A23.3 (-14, -04), Design of Concrete Structures, CSA Group.

Compliance with the following codes:

Wood-Knocker® II+ concrete inserts and Bang-It®+ concrete inserts for steel deck in cracked and uncracked concrete, as described in this listing report, are in conformance with CSA A23.3 (-14, 04), Annex D, as referenced in the applicable section of the following code editions:

- *National Building Code of Canada*® 2015 and 2010
Applicable Section: Division B, Part 4, Section 4.3.3.

Description of anchors:

The Wood-Knocker II+ inserts are cast-in concrete form inserts. The inserts consists of a steel internally threaded headed insert (body), an outer plastic sleeve and nails used to attach the insert to the inside surface of concrete formwork. The inserts are illustrated in Figure 1 and Figure 3. The internally threaded inserts are manufactured from low carbon steel. The Wood-Knocker inserts have minimum 5 µm (0.002-inch) zinc plating. The plastic sleeve is fabricated from polypropylene.

The Bang-It+ steel deck inserts are cast-in concrete inserts. The insert consists of a steel internally threaded headed insert (body), an outer spring, a plastic sleeve and a washer (base plate). The insert is illustrated in Figure 2 and Figure 4. The internally threaded insert and washer are manufactured from low carbon steel. The Bang-It+ inserts have a minimum 5 µm (0.002-inch) zinc plating. The spring is manufactured from steel music wire. The plastic sleeve is fabricated from polypropylene.

The anchor assembly is comprised of a Wood-Knocker II+ or Bang-It+ insert with a threaded steel element (e.g. rod or bolt). The Wood-Knocker II+ insert is installed on the inside surface of wood formwork and the head driven down until it comes into contact with the plastic sleeve and the nails enter the form. The Bang-It+ insert is installed in a predrilled hole in the topside of the metal deck, and impacted with sufficient force to compress the spring and drive the flared plastic fins of the sleeve completely through the hole. Concrete can then be cast over the insert.

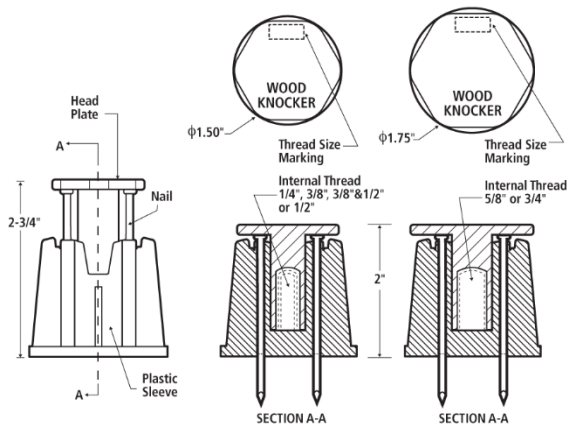


FIGURE 1— WOOD-KNOCKER II+ CAST-IN-PLACE INSERTS FOR FORM POUR CONCRETE Before Setting (head plate starting position) and After Setting (head plate and nails down)

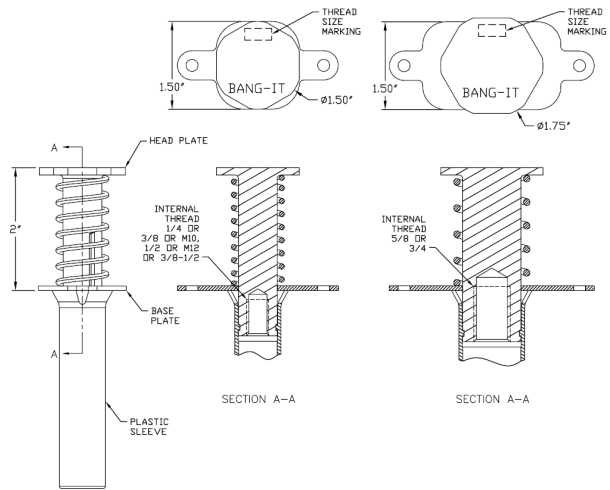


FIGURE 2—BANG-IT+ CAST-IN-PLACE INSERTS FOR CONCRETE FILLED STEEL DECK FLOOR AND ROOF ASSEMBLIES



FIGURE 3—WOOD-KNOCKER II+ CONCRETE INSERTS

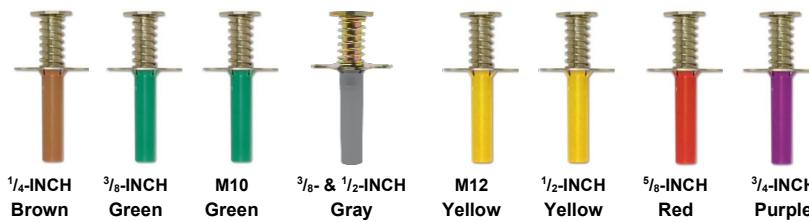


FIGURE 4—BANG-IT+ INSERTS FOR CONCRETE-FILLED STEEL DECKS

Identification:

1. The inserts are identified by packaging labeled with the insert size, lot number, company name, listing report number (ELC-3657), and the ICC-ES listing mark. The inserts have the letters Wood-Knocker or Bang-It+, as applicable, and the specific size embossed atop the head of the insert, visible prior to installation for verification.
2. The report holder's contact information is the following:

DEWALT
701 EAST JOPPA ROAD
TOWSON, MARYLAND 21286
(800) 524-3244
www.dewalt.com
engineering@powers.com

Installation: The installation parameters are provided in Figure 5A and 5B. Installation of the inserts must be in accordance with the manufacturer's published installation instruction (MPII) as provided in the packaging and described in and Figure 5A and 5B.


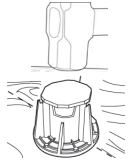

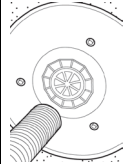
WOOD-KNOCKER II+				
	1.) Position insert on formwork, plastic down.	2.) Drive insert down until head contacts plastic.	3.) After formwork removal, remove nails as necessary (e.g. flush mounted fixtures).	4.) Install threaded steel element (rod/bolt) into the insert by pushing through plastic center (thread seal). Attach fixture as applicable (e.g. seismic brace).
	POSITION	DRIVE	PREPARE	ATTACH

FIGURE 5A—WOOD KNOCKER II+ CONCRETE INSERTS, MANUFACTUER PUBLISHED INSTALLATION INSTRUCTIONS (MPII)

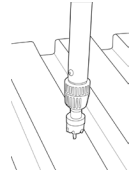
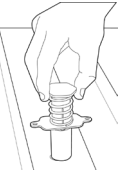
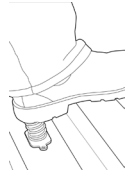
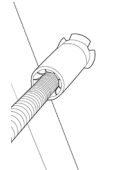
BANG-IT+				
	1.) Cut (e.g. drill/punch) a hole in the steel deck to the hole size required by the insert.	2.) Place the plastic sleeve of the insert through hole in steel deck.	3.) Step on or impact the insert head to engage. Optionally, base plate of insert can also be screwed to steel deck.	4.) Install threaded steel element (rod/bolt) into the insert. Trim away plastic sleeve for shear load applications and attach fixture as applicable (e.g. seismic brace).
	CREATE HOLE	POSITION	PREPARE	ATTACH

FIGURE 5B—BANG-IT+ CONCRETE INSERTS FOR STEEL DECK, MANUFACTUER PUBLISHED INSTALLATION INSTRUCTIONS (MPII)

Anchor setting information:

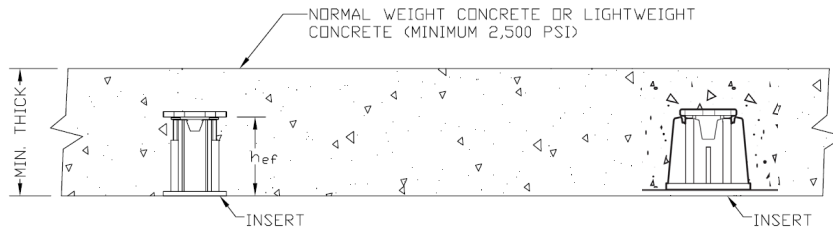


FIGURE 6—WOOD-KNOCKER II+ INSERTS INSTALLED IN FORM POUR CONCRETE FLOOR AND ROOF ASSEMBLIES

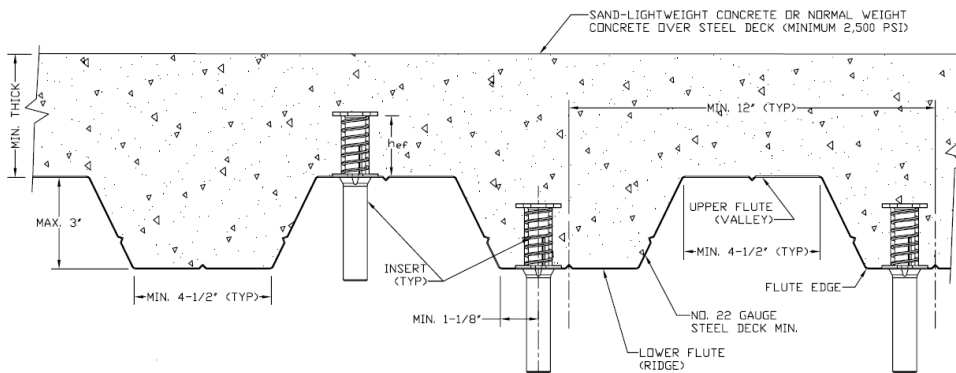


FIGURE 7A—BANG-IT+ INSERTS INSTALLED IN SOFFIT OF CONCRETE FILLED STEEL DECK FLOOR AND ROOF ASSEMBLIES^{1,2,3,4}

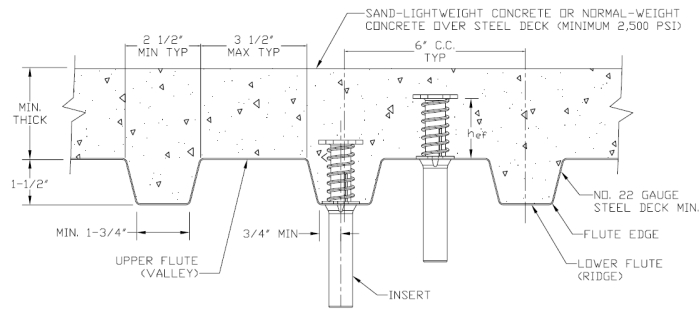


FIGURE 7B—BANG-IT+ INSERTS INSTALLED IN SOFFIT OF CONCRETE FILLED STEEL DECK FLOOR AND ROOF ASSEMBLIES^{1,2,3,5,6,7}

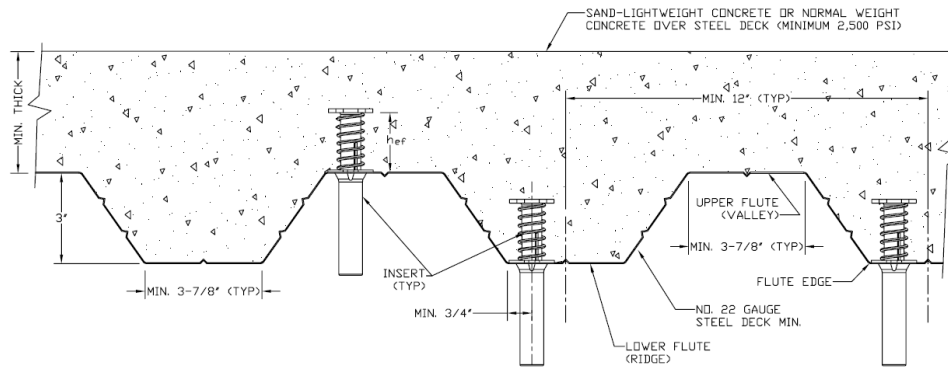


FIGURE 7C—BANG-IT+ INSERTS INSTALLED IN SOFFIT OF CONCRETE FILLED STEEL DECK FLOOR AND ROOF ASSEMBLIES^{1,2,3,8}

¹Inserts may be placed in the upper flute or lower flute of the steel deck assembly. Inserts in the lower flute require a minimum 37mm (1.5-inch) of concrete topping thickness (min. thick in Figures) from the top of the upper flute. Upper flute installations require a minimum 74mm (3-inch) concrete topping thickness from the top of the upper flute. Inserts in upper flute may be installed anywhere across upper flute.

²Axial spacing for Bang-It+ inserts along the lower flute length shall be minimum $3h_{ef}$.

³Upper flute Bang-It+ inserts are not subject to steel deck dimension limitations or the minimum steel deck gauge limitations.

⁴Inserts in the lower flute of Figure 7A may be installed with a maximum 29mm (1¹/₈-inch) offset in either direction from the center of the flute. The offset distance may be increased for flute widths greater than those shown provided the minimum lower flute edge distance of 29mm (1¹/₈-inch) is also satisfied.

⁵Inserts in the lower flute of Figure 7B may be installed with a maximum 3mm (1/8-inch) offset in either direction from the center of the flute. The offset distance may be increased for flute widths greater than those shown provided the minimum lower flute edge distance of 19mm (3/4-inch) is also satisfied.

⁶Lower flute installations of Figure 7B with flutes widths greater than 44mm (1³/₄-inch) are permitted.

⁷Lower flute installations of Figure 7B in flute depths greater than 38mm (1¹/₂-inch) are permitted provided the minimum edge distance of 19mm (3/4-inch) is met and the minimum lower flute width is increased proportionally [e.g. applicable to a lower flute depth of 51mm (2-inch) with a minimum lower flute width of 57mm (2¹/₄-inch)].

⁸Inserts in the lower flute of Figure 7C may be installed with a maximum 30mm (1³/₁₆-inch) offset in either direction from the center of the flute.

Ultimate Limit States Design:

Design resistance of anchors for compliance with the 2015 NBCC must be determined in accordance with CSA A23.3-14 Annex D, and this listing report.

Design resistance of anchors for compliance with the 2010 NBCC must be determined in accordance with CSA A23.3-04 Annex D, and this listing report.

Design parameters provided in Table 1 through 4 of this listing report are based on the 2015 NBCC and 2010 NBCC (CSA A23.3-14 and CSA A23.3-04). The limit states design of anchors must comply with CSA A23.3 (-14, -04) D.5.1, except as required in CSA A23.3 (-14, -04) D.4.3.1.

Material resistance factors must be $\phi_c = 0.65$ and $\phi_s = 0.85$ in accordance with CSA A23.3 (-14, 04) Sections 8.4.2 and 8.4.3, and resistance modification factor, R , as given in CSA A23.3-14 Section D.5.3, or CSA A23.3-04 Section D.5.4, and noted in Tables 1, 2 and 4 of this listing report, must be used for load combinations calculated in accordance with Division B, Part 4, Section 4.1.3 of the 2015 and 2010 NBCC, or Annex C of CSA A23.3 (-14, -04). The nominal strength N_{sa} or V_{sa} , in Tables 1, 2, and 4 of this listing report must be multiplied by ϕ_s and R to determine the factored resistance N_{sar} or V_{sar} .

TABLE 1—WOOD KNOCKER II+ INSERT DESIGN INFORMATION^{1,2,3,4,5,6,7}

DESIGN INFORMATION	SYMBOL	UNITS	1/4-inch	3/8-inch	M10	M12	1/2-inch	5/8-inch	3/4-inch	
Insert O.D.	d_a	mm	18				25			
Insert head net bearing area	A_{brg}	mm ²	762				839			
Effective embedment depth	h_{ef}	mm	45				45			
Minimum member thickness	h_{min}	mm	89				89			
Minimum spacing and edge distances	s_{min}, c_{min}	-	See CSA A23.3 (-14, -04) Section D.9							
Effectiveness factor for cracked concrete	k_c	SI	10							
Modification factor for tension strength in uncracked concrete	$\psi_{C,N}$	-	1.25							
Nominal tension strength of single insert as governed by steel strength	$N_{sa,insert}$	kN	45.7				40.1	56.4		
Nominal tension strength of single insert as governed by steel strength, seismic	$N_{sa,insert,eq}$	kN	45.7				40.1	56.4		
Nominal steel shear strength of single insert	$V_{sa,insert}$	kN	31.9				31.9	40.4		
Nominal steel shear strength of single insert, seismic	$V_{sa,insert,eq}$	kN	31.9				31.9	40.4		
Resistance modification factor for tension, steel failure modes	R	-	0.70							
Resistance modification factor for shear, steel failure modes	R	-	0.65							
Resistance modification factor for tension and shear, concrete failure modes, Condition B ⁸	R	-	1.00							

For SI: 1 inch = 25.4 mm, 1 pound = 0.00445 kN, 1 psi = 0.006895 MPa. For pound-inch unit: 1 mm = 0.03937 inches.

¹Concrete must have a compressive strength f'_c of 17.2MPa minimum. Installation must comply with Figure 5A and this listing report.

²Design of headed cast-in specialty inserts shall be in accordance with the provisions of CSA A23.3 (-14, -04) Annex D for cast-in headed anchors. Concrete breakout strength must also be in accordance with Figure 6.

³The values of the material resistance factors ϕ_c and ϕ_s , and resistance modification factor, R , applies when the load combinations of Division B, Part 4, Section 4.1.3 of the 2015 NBCC or 2010 NBCC, or Annex C of CSA A23.3 (-14, -04) are used. The R values correspond to brittle steel elements.

⁴Insert O.D. is the outside diameter of the headed insert body.

⁵Minimum spacing distance between anchors and minimum edge distance for cast-in headed Wood Knocker II+ anchors shall be in accordance with CSA A23.3 (-14, -04) Section D.9.

⁶Only the largest size of threaded rod or bolt for the 3/8- & 1/2-inch multi insert (i.e. 1/2-inch diameter) must be used for applications resisting shear loads.

⁷The strengths shown in the table are for inserts only. Design professional is responsible for checking threaded rod or bolt strength in tension, shear, and combined tension and shear, as applicable. See Table 5 for steel design information for common threaded rod elements.

⁸Condition B applies where supplemental reinforcement is not provided or where pullout governs, as set forth in CSA A23.3-14 D.5.3(c) or CSA A23.3-04 D.5.4(c).

TABLE 2—BANG-IT+ INSERT DESIGN INFORMATION^{1,2,3,4,5,6,7,8}

DESIGN INFORMATION		SYMBOL	UNITS	1/4-inch	3/8-inch	M10	M12	1/2-inch	5/8-inch	3/4-inch	
Insert O.D.		d_a	mm	18					25		
Insert head net bearing area		A_{brg}	mm ²	762					839		
Effective embedment depth		h_{ef}	mm	45					45		
Minimum member thickness		h_{min}	-	See Figures 7A, 7B and 7C as applicable							
Minimum spacing and edge distances	Upper flute	S_{min}, C_{min}	-	See CSA A23.3 (-14, -04) Section D.9							
	Lower flute	S_{min}, C_{min}	-	See Figures 7A, 7B and 7C as applicable							
Effectiveness factor for cracked concrete		k_c	SI	10							
Modification factor for tension strength in uncracked concrete		$\psi_{C,N}$	-	1.25							
According to Figures 7A, 7B & 7C	Nominal tension strength of single insert as governed by steel strength	$N_{sa,insert}$	kN	46.4			43.8		53.3		
	Nominal tension strength of single insert as governed by steel strength, seismic	$N_{sa,insert,eq}$	kN	46.4			43.8		53.3		
Resistance modification factor for tension, steel failure modes		R	-	0.70							
Resistance modification factor for tension, concrete failure modes, Condition B ⁸		R	-	1.00							

For SI: 1 inch = 25.4 mm, 1 pound = 4.45 N, 1 psi = 0.006895 MPa. For pound-inch unit: 1 mm = 0.03937 inches.

¹Concrete must have a compressive strength f'_c of 17.2MPa minimum. Installation must comply with Figure 5B and this listing report.

²Design of headed cast-in specialty inserts shall be in accordance with the provisions of CSA A23.3 (-14, -04) Annex D for cast-in headed anchors. Concrete breakout strength must also be in accordance with Figures 7A, 7B, 7C, and 8, as applicable.

³The values of the material resistance factors ϕ_c and ϕ_s , and resistance modification factor, R , applies when the load combinations of Division B, Part 4, Section 4.1.3 of the 2015 NBCC or 2010 NBCC, or Annex C of CSA A23.3 (-14, -04) are used. The R values correspond to brittle steel elements.

⁴Insert O.D. is the outside diameter of the headed insert body.

⁵Minimum spacing distance between anchors and minimum edge distances for cast-in headed Bang-It+ anchors shall be in accordance with Figures 7A, 7B or 7C, and CSA A23.3 (-14, -04) Section D.9, as applicable, and noted provisions.

⁶The strengths shown in the table are for inserts only. Design professional is responsible for checking threaded rod strength, as applicable. See Table 4 for steel design information for common threaded rod elements.

⁷The tabulated insert strength values are applicable to installations in the lower flute or upper flute of the steel deck profiles; see Figures 7A, 7B and 7C.

⁸Condition B applies where supplemental reinforcement is not provided or where pullout governs, as set forth in CSA A23.3-14 D.5.3(c) or CSA A23.3-04 D.5.4(c).

TABLE 3—SPECIFICATIONS AND PHYSICAL PROPERTIES OF COMMON CARBON STEEL THREADED ROD ELEMENTS¹

THREADED ROD SPECIFICATION		UNITS	MIN. SPECIFIED ULTIMATE STRENGTH, f_{uta}	MIN. SPECIFIED YIELD STRENGTH 0.2 PERCENT OFFSET, f_{ya}	f_{uta} — f_{ya}	ELONGATION MINIMUM PERCENT ⁶	REDUCTION OF AREA MIN. PERCENT	RELATED NUT SPECIFICATION ⁸
Carbon Steel	ASTM A36/A36M ² and F1554 ³ Grade 36	MPa	400	248	1.61	23	40 (50 for A36)	ASTM A194 / A563 Grade A
	ISO 898-1 ⁵ Class 4.6	MPa	400	240	1.67	22	- ⁷	ISO 4032 Grade 4
	ASTM F1554 ³ Grade 105	MPa	862	724	1.19	15	45	ASTM A194 / A563 Grade DH
	ASTM A193/A193M ⁴ Grade B7	MPa	860	720	1.19	16	50	

For SI: 1 inch = 25.4 mm, 1 psi = 0.006897 MPa. For pound-inch units: 1 mm = 0.03937 inch, 1 MPa = 145.0 psi.

¹Inserts may be used in conjunction with all grades of continuously threaded carbon steels (all-thread) that comply with code reference standards and that have thread characteristics comparable with ANSI B1.1 UNC Coarse Thread Series or ANSI B1.13M M Profile Metric Coarse Thread Series. Tabulated values correspond to anchor diameters included in this report.

²Standard Specification for Carbon Structural Steel.

³Standard Specification for Anchor Bolts, Steel, 36, 55, and 105-ksi Yield Strength.

⁴Standard Specification for Alloy-Steel and Stainless Steel Bolting Materials for High Temperature or High Pressure Service and Other Special Purpose Applications.

⁵Mechanical properties of fasteners made of carbon steel and alloy steel – Part 1: Bolts, screws and studs.

⁶Based on 2-inch (50 mm) gauge length except ASTM A193, which are based on a gauge length of 4d.

⁷Minimum percent reduction of area not reported in the referenced standard.

⁸Where nuts are applicable, nuts of other grades and style having specified proof load stress greater than the specified grade and style are also suitable.

TABLE 4—STEEL DESIGN INFORMATION FOR COMMON THREADED ROD ELEMENTS USED WITH CONCRETE INSERTS^{1,2,3,4}

DESIGN INFORMATION		SYMBOL	UNITS	1/4-inch	3/8-inch	M10	M12	1/2-inch	5/8-inch	3/4-inch
Threaded rod nominal outside diameter		d_{rod}	mm (in.)	6.4 (0.250)	9.5 (0.375)	10 (0.394)	12 (0.472)	12.7 (0.500)	15.9 (0.625)	19.1 (0.750)
Threaded rod effective cross-sectional area		A_{se}	mm ² (in ²)	21 (0.032)	50 (0.078)	58 (0.090)	85 (0.131)	92 (0.142)	146 (0.226)	216 (0.335)
ASTM A36	Nominal tension strength of threaded rod as governed by steel strength	$N_{sa,rod,A36}$	kN	8.2	20	23.2	33.8	36.6	58.3	86.3
	Nominal tension strength of threaded rod as governed by steel strength, seismic	$N_{sa,rod,eq,A36}$	kN	8.2	20	23.2	33.8	36.6	58.3	86.3
	Nominal shear strength of threaded rod as governed by steel strength	$V_{sa,rod,A36}$	kN	4.9	12.0	13.9	20.3	22.0	35.0	51.8
	Nominal shear strength of threaded rod as governed by steel strength, seismic	$V_{sa,rod,eq,A36}$	kN	3.5	8.4	9.7	14.2	15.4	24.5	36.3
	Resistance modification factor for tension	R	-	0.80						
	Resistance modification factor for shear	R	-	0.75						
ASTM A193, Grade B7	Nominal tension strength of threaded rod as governed by steel strength	$N_{sa,rod,B7}$	kN	17.7	43.1	50.1	72.9	78.9	125.7	186.0
	Nominal tension strength of threaded rod as governed by steel strength, seismic	$N_{sa,rod,eq,B7}$	kN	17.7	43.1	50.1	72.9	78.9	125.7	186.0
	Nominal shear strength of threaded rod as governed by steel strength	$V_{sa,rod,B7}$	kN	10.6	25.9	30.0	43.7	47.3	75.4	111.6
	Nominal shear strength of threaded rod as governed by steel strength, seismic	$V_{sa,rod,eq,B7}$	kN	7.5	18.2	21.0	30.6	34.2	52.8	78.2
	Resistance modification factor for tension	R	-	0.80						
	Resistance modification factor for shear	R	-	0.75						

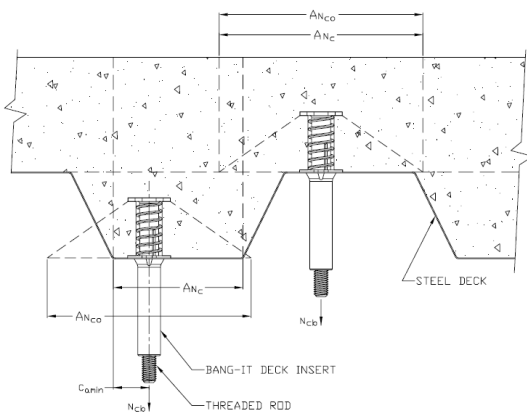
For **SI**: 1 inch = 25.4 mm, 1 pound = 0.00445 kN, 1 in² = 645.2 mm². For **pound-inch** unit: 1 mm = 0.03937 inches.

¹Values provided for steel element material types, or equivalent, based on minimum specified strengths; $N_{sa,rod}$ and $V_{sa,rod}$ Calculated in accordance with CSA A23.3-14 Eq. D.2 and Eq. D.31, as applicable. $V_{sa,rod,eq}$ must be taken as $0.7V_{sa,rod}$.

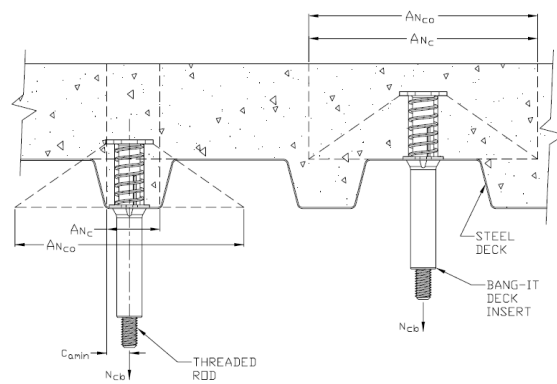
² $N_{sa} \cdot R$ shall be the lower of the $N_{sa,rod} \cdot R$ or $N_{sa,insert} \cdot R$ for static steel strength in tension; for seismic loading $N_{sa,eq} \cdot R$ shall be the lower of the $N_{sa,rod,eq} \cdot R$ or $N_{sa,insert,eq} \cdot R$.

³ $V_{sa} \cdot R$ shall be the lower of the $V_{sa,rod} \cdot R$ or $V_{sa,insert} \cdot R$ for static steel strength in tension; for seismic loading $V_{sa,eq} \cdot R$ shall be the lower of the $V_{sa,rod,eq} \cdot R$ or $V_{sa,insert,eq} \cdot R$.

⁴ The value of the material resistance factors ϕ_c and ϕ_s , and resistance modification factor, R , applies when the load combinations of Division B, Part 4, Section 4.1.3 of the 2015 NBCC or Annex C of CSA A23.3-14 are used. The R values correspond to ductile steel elements.



Idealization of Steel Deck Profile (e.g. see Figures 4A and 4C)



Idealization of Steel Deck Profile (e.g. see Figure 4B)

FIGURE 8—IDEALIZATION OF CONCRETE FILLED STEEL DECKS FOR DETERMINATION OF CONCRETE BREAKOUT STRENGTH IN ACCORDANCE WITH ACI 318

Conditions of listing:

1. The listing report addresses only conformance with the standards and code sections noted above.
2. Approval of the product's use is the sole responsibility of the local code official.
3. The listing report applies only to the materials tested and as submitted for review by ICC-ES.
4. Specialty insert sizes, dimensions, minimum embedment depths, and other installation parameters are as set forth in this listing report.
5. Specialty inserts must be limited to use in cracked and uncracked normal-weight concrete, sand-lightweight concrete and all-lightweight concrete having a specified compressive strength, f_c , of 17.2 MPa to 68.9 MPa for the Wood-Knocker inserts, and in cracked and uncracked normal-weight or sand-lightweight concrete filled steel deck assemblies having a specified compressive strength, 17.2 MPa to 68.9 MPa for the Bang-It+ inserts.
6. The values of f_c used for calculation purposes must not exceed 68.9 MPa.
7. Limit states design values must be established in accordance with this listing report.
8. The use of fatigue or shock loading for these anchors under such conditions is beyond the scope of this listing report.
9. Anchors may be used to resist short-term loading due to wind or seismic forces in locations designed according to NBCC 2015.
10. Where not otherwise prohibited in the code as referenced in CSA A23.3-14, Wood-Knocker® II+ concrete inserts and Bang-It®+ concrete inserts are permitted for use with fire-resistance-rated construction provided that at least one of the following conditions is fulfilled:
 - a. Anchors are used to resist wind or seismic forces only.
 - b. Anchors that support a fire-resistance-rated envelope or a fire-resistance-rated membrane are protected by approved fire-resistance-rated materials, or have been evaluated for resistance to fire exposure in accordance with recognized standards.
 - c. Anchors are used to support nonstructural elements.
11. Use of zinc-coated carbon steel anchors is limited to dry, interior locations.