



**DIVISION: 03 00 00—CONCRETE**  
**Section: 03 15 00—Concrete Accessories**  
**Section: 03 16 00—Concrete Anchors**

**DIVISION: 04 00 00—MASONRY**  
**Section: 04 05 19.16—Masonry Anchors**

**DIVISION: 05 00 00—METALS**  
**Section: 05 05 23—Metal Fastenings**

**DIVISION: 06 00 00—WOOD, PLASTICS AND COMPOSITES**  
**Section: 06 05 23—Wood, Plastic and Composite Fastenings**

**DIVISION: 09 00 00—FINISHES**  
**Section: 09 22 16.23—Fasteners**

**REPORT HOLDER:**

HILTI, INC.

**EVALUATION SUBJECT:**

**HILTI LOW-VELOCITY POWER-ACTUATED FASTENERS**

**1.0 EVALUATION SCOPE**

**Compliance with the following codes:**

- 2021, 2018, 2015 and 2012 *International Building Code*® (IBC)
- 2021, 2018, 2015 and 2012 *International Residential Code*® (IRC)

For evaluation for compliance with codes adopted by the Los Angeles Department of Building and Safety (LADBS), see [ESR-1663 LABC and LARC Supplement](#).

**Property evaluated:**

Structural

**2.0 USES**

Hilti low-velocity power-actuated fasteners (PAFs) are used to attach wood, cold-formed steel, and other building elements to base materials of normalweight and sand-lightweight concrete, steel deck panels filled with sand-lightweight concrete, concrete masonry and steel base materials. The fasteners are alternatives to the cast-in-place

anchors described in IBC Section 1901.3 (2012 IBC Section 1908) for placement in concrete; the embedded anchors described in Section 8.1.3 of TMS 402, referenced in Section 2107 of the IBC (Section 2.1.4 of TMS 402-11, referenced in Section 2107 of the 2012 IBC) for placement in masonry; and the welds and bolts used to attach materials to steel, described in IBC Sections 2204.1 and 2204.2, respectively. For structures regulated under the IRC, the fasteners may be used where an engineered design is submitted in accordance with IRC Section R301.1.3.

**3.0 DESCRIPTION**

**3.1 Fasteners:**

The Hilti low-velocity power-actuated fasteners are manufactured from hardened steel complying with the material specifications in the manufacturer's quality documentation. See Table 1 for fastener descriptions, including shank type and diameter, head diameter, coating and applicable allowable load tables. See Figure 1 for fastener images. Maximum point length is the maximum specified length from the tip of the fastener to the location where the diameter of the shank becomes constant. Minimum effective shank length is the minimum specified length from the underside of the fastener head to the tip of the fastener, except for fasteners with premounted washers, where the minimum effective shank length is the minimum specified length from the underside of the washer, in its installed condition, to the tip of the fastener.

**3.2 Substrate Materials:**

**3.2.1 Concrete:** Normalweight and sand-lightweight concrete must comply with IBC Chapter 19 or IRC Section R402.2, as applicable. The minimum concrete compressive strength at the time of fastener installation must be as noted in Table 4.

**3.2.2 Concrete Masonry:** Concrete masonry units (CMUs) must be minimum 8-inch-thick (203 mm), normalweight blocks complying with ASTM C90. Mortar must comply with ASTM C270, Type N. Grout must be coarse grout complying with ASTM C476. Concrete masonry walls must have a minimum compressive strength,  $f'_m$ , of 1,500 psi (10.3 MPa).

**3.2.3 Steel:** Structural steel used in supports must comply with the minimum requirements of ASTM A36, ASTM A572 Grade 50 or ASTM A992, as applicable, and must have the minimum yield and tensile strengths and thickness shown in Table 2 or 3, as applicable.

**3.2.4 Steel Deck Panels:** Steel deck panel properties and configurations must be as described in Tables 5 and 6 and Figures 2 through 4.

## 4.0 DESIGN AND INSTALLATION

### 4.1 Design:

**4.1.1 General:** Selection of fasteners must take into consideration the applicable base material and the length of the fastener. The minimum fastener length must be determined as follows:

- For installation into concrete, concrete-filled steel deck panels and concrete masonry materials and into steel base materials where there is no point penetration, the minimum effective shank length shown in Table 1 must equal or exceed the sum of the thickness of the attached material and the minimum embedment depth (penetration) shown in the applicable tables in this report.
- For installation through steel base material, the minimum effective shank length shown in Table 1 must equal or exceed the sum of the following: the thickness of the attached material, the thickness of the base material and the required point penetration shown in the applicable tables in this report.

**4.1.2 Allowable Loads:** The applicable allowable load tables for Hilti power-actuated fasteners driven into different base materials may be determined by referencing Table 1.

The most critical applied loads, excluding seismic load effects, resulting from the load combinations in Section 2.4 of ASCE 7-16/S1 (referenced in 2021 IBC Section 1605.1) or IBC Section 1605.2 (Section 1605.3.1 or 1605.3.2 of the 2018, 2015 and 2012 IBC) must not exceed the allowable loads. For fasteners which are subjected to seismic loads, see Section 4.1.5 for additional information. The stress increases and load reductions described in 2021 IBC Section 1605.2 (2018, 2015 and 2012 IBC Section 1605.3) are not allowed.

Allowable shear loads and tension (pullout) loads in this report apply to the connection of the fastener to the base material only. Other limit states applicable to the design of a connection, such as fastener pull-through (pull-over) and lateral bearing on the attached material, which are governed by the properties of the attached material, are outside the scope of this report. Design of the connection to the attached material must comply with the applicable requirements of the IBC. When designing the connection of wood members to the base material, the bending yield strength of the PAFs can be assumed to be the same as that of a nail with the same shank diameter.

**4.1.3 Combined Loading:** For fasteners subjected to both tension and shear loads, compliance with the following interaction equation must be verified:

$$(p/P_a) + (v/V_a) \leq 1.0$$

where:

- p = Actual tension load on the fastener, lbf (N).
- P<sub>a</sub> = Allowable tension load for the fastener, lbf (N).
- v = Actual shear load on the fastener, lbf (N).
- V<sub>a</sub> = Allowable shear load for the fastener, lbf (N).

**4.1.4 Steel-to-steel Connections:** When the Hilti fasteners listed in Tables 2 and 3 are used in connections of two steel elements in accordance with Section J5 of AISI S100 (Section E5 of AISI S100-12 for the 2015 and 2012 IBC), connection capacity must be determined in accordance with Sections 4.1.4.1 and 4.1.4.2, as applicable.

**4.1.4.1 Connection Strength - Tension:** To determine tensile connection strength in accordance with Section J5.2 of AISI S100 (Section E5.2 of AISI S100-12), fastener

tension strength, the pull-out strength and the pull-over strength must be known. These characteristics must be determined as follows:

- **Pull-out Strength:** See Table 2 or 3 for available pull-out strength, as applicable.
- **Pull-over Strength:** The available pull-over strengths must be calculated in accordance with Section J5.2.3 of AISI S100 (Section E5.2.3 of AISI S100-12).
- **PAF Tensile Strength:** The allowable fastener tension strengths, determined in accordance with Section J5.2.1 of AISI S100 (Section E5.2.1 of AISI S100-12), exceed the corresponding allowable pull-out strengths in Tables 2 and 3.

**4.1.4.2 Connection Strength - Shear:** To determine shear connection strength in accordance with Section J5.3 of AISI S100 (Section E5.3 of AISI S100-12), the fastener shear strength, bearing and tilting strength, pull-out strength in shear, net section rupture strength and shear strength limited by edge distance must be known. These characteristics must be determined as follows:

- **Bearing and Tilting Strength:** The available bearing and tilting strengths must be calculated in accordance with Section J5.3.2 of AISI S100 (Section E5.3.2 of AISI S100-12).
- **Pull-out Strength in Shear:** The available pull-out strength in shear must be the applicable allowable shear strength from Table 2 or 3, as applicable, or must be calculated in accordance with Section J5.3.3 of AISI S100 (Section E5.3.3 of AISI S100-12).
- **Net Section Rupture Strength and Shear Strength Limited by Edge Distance:** The net section rupture strength must be determined in accordance with Section J5.3.4 of AISI S100 (Section E5.3.4 of AISI S100-12) and the shear strength limited by edge distance must be determined in accordance with Section J5.3.5 of AISI S100 (Section E5.3.5 of AISI S100-12).
- **PAF Shear Strength:** The allowable fastener shear strengths, determined in accordance with Section J5.3.1 of AISI S100 (Section E5.3.1 of AISI S100-12), exceed the corresponding allowable shear strengths in Tables 2 and 3.

**4.1.5 Seismic Considerations:** When subjected to seismic loads, the Hilti fasteners may be used as follows:

1. The Hilti fasteners may be used for attachment of nonstructural components listed in Section 13.1.4 of ASCE 7, which are exempt from the requirements of ASCE 7.
2. Concrete base materials: The Hilti fasteners installed in concrete may be used to support acoustical tile or lay-in panel suspended ceiling systems, distributed systems and distribution systems where the service load on any individual fastener does not exceed the lesser of 90 lbf (400 N) or the published allowable load in Tables 4, 5 and 6, as applicable.
3. Steel base materials: When the Hilti fasteners listed in Table 2 or 3 [except for the X-R fastener and the X-ENP-19 L15 fastener installed in 1/4-inch-thick (6.4 mm) steel] are installed in steel and subjected to seismic loads, the most critical load applied to each individual fastener must be determined from the applicable equations in Section 2.4 of ASCE 7-16/S1 (referenced in 2021 IBC Section 1605.1) or IBC Section 1605.2 (Section 1605.3.1 or Section 1605.3.2

of the 2018, 2015 and 2012 IBC), and must not exceed the allowable load shown in Table 2 or 3, as applicable, taking into account the footnotes to the applicable table. The X-R fastener and the X-ENP-19 L15 fastener installed in 1/4-inch-thick (6.4 mm) steel may be used where the service load on any individual fastener does not exceed the lesser of 250 lbf (1112 N) or the published allowable load shown in Table 2 or 3, as applicable. Evaluation of the Hilti fasteners installed in steel base material for use in the design of lateral force resisting systems, such as shear walls and diaphragms, is outside the scope of this report.

4. For interior, nonstructural walls that are not subject to sustained tension loads and are not a bracing application, the power-actuated fasteners may be used to attach steel track to concrete or steel in all Seismic Design Categories. In Seismic Design Categories D, E, and F, the allowable shear load due to transverse pressure shall be no more than 90 pounds (400 N) when attaching to concrete; or the allowable load shown in Table 2 or 3, as applicable, when attaching to steel. Substantiating calculations shall be submitted addressing the fastener-to-base-material capacity and the fastener-to-attached-material capacity. Interior nonstructural walls are limited to locations where bearing walls, shear walls or braced walls are not required by the approved plans. The design load on the fastener must not exceed the allowable load established in this report for the concrete or steel base material.

#### 4.2 Installation:

**4.2.1 General:** The fasteners must be installed in accordance with this report and the Hilti, Inc., published installation instructions. A copy of the instructions must be available on the jobsite at all times during installation. Additional installation requirements are set forth in the tables in this report.

Fastener placement requires a low-velocity powder-actuated tool used in accordance with Hilti, Inc. recommendations.

Installers must be certified by Hilti, Inc., and have a current, Hilti-issued, operator's license.

**4.2.2 Fastening to Steel:** When installation is in steel, minimum spacing between fasteners must be 1 inch (25.4 mm) on center, and minimum edge distance must be 1/2 inch (12.7 mm).

**4.2.3 Fastening to Concrete:** Fasteners are to be driven into the concrete after the concrete attains the concrete strength specified in the tables of this report. Unless otherwise noted, minimum spacing between fasteners must be 4 inches (102 mm) on center and minimum edge distance must be 3 inches (76 mm). Unless otherwise noted, concrete thickness must be a minimum of three times the embedment depth of the fastener.

**4.2.4 Fastening to Masonry:** Fasteners are to be driven into the masonry after the mortar and grout materials have attained the specified strength. For CMUs, no more than one power-actuated fastener may be installed into each individual CMU cell.

**4.2.5 Fastening to Sand-lightweight Concrete-filled Steel Deck Panels:** Installation in sand-lightweight concrete-filled steel deck panels must comply with Tables 5 and 6 and Figures 2 through 4. Minimum distances from fastener centerline to rolled deck panel flute edges must be as depicted in Figures 2 through 4.

**4.2.6 Use with Treated Lumber:** The Hilti carbon steel fasteners described in Table 1 may be used in contact with fire-retardant-treated wood in dry, interior locations only, in accordance with IBC Section 2304.10.6.4 (2018 and 2015 IBC Section 2304.10.5.4, 2012 IBC Section 2304.9.5.4) and Hilti's recommendations. Use of fasteners in contact with preservative-treated wood or fire-retardant-treated wood in exterior applications is outside the scope of this report

#### 5.0 CONDITIONS OF USE

The Hilti Low-Velocity Power-Actuated Fasteners described in this report comply with, or are suitable alternatives to what is specified in, those codes listed in Section 1.0 of this report, subject to the following conditions:

- 5.1 Fasteners must be manufactured and identified in accordance with this report.
- 5.2 Fasteners must be installed in accordance with this report and the Hilti, Inc., instructions. In the event of conflict between this report and Hilti, Inc., published instructions, the more restrictive requirements govern.
- 5.3 Calculations demonstrating that the actual loads are less than the allowable loads described in Section 4.1 must be submitted to the code official for approval. The calculations must be prepared by a registered design professional where required by the statutes of the jurisdiction in which the project is constructed.
- 5.4 For steel-to-steel connections that meet the applicability requirements of Section J5 of AISI S100-16, calculations demonstrating that the available connection strength has been determined in accordance with Section J5 of AISI S100 (Section E5 of AISI S100-12 for the 2015 and 2012 IBC) and Section 4.1.4 of this report, and equals to or exceeds the applied load, must be submitted to the code official. The calculations must be prepared by a registered design professional where required by the statutes of the jurisdiction in which the project is to be constructed.
- 5.5 Refer to Section 4.1.5 for seismic considerations.
- 5.6 Diaphragm design values using the X-ENP-19 L15 fasteners must be determined in accordance with ESR-2197 and ESR-2776, as applicable.
- 5.7 The use of the fasteners is limited to installations in uncracked concrete or masonry. Cracking occurs when  $f_t > f_r$  due to service loads or deformations.
- 5.8 Hilti X-CR and X-R stainless steel fasteners may be used in exterior, damp environments. All other fasteners in this report must be limited to installation in dry, interior environments, which include exterior walls which are protected by an exterior wall envelope.
- 5.9 Installation must comply with Section 4.2.6 regarding fasteners in contact with preservative-treated and fire-retardant-treated wood.
- 5.10 Installers must be certified by Hilti, Inc., and have a current, Hilti-issued, operator's license.
- 5.11 The Hilti products addressed in this report are manufactured under a quality-control program with inspections by ICC-ES.

#### 6.0 EVIDENCE SUBMITTED

Data in accordance with the ICC-ES Acceptance Criteria for Power-actuated Fasteners Driven into Concrete, Steel, and Masonry Elements (AC70), dated December 2019 (editorially revised January 2021), including seismic load test data in accordance with Annex A of AC70.

**7.0 IDENTIFICATION**

7.1 All carbon steel fasteners are identified by an “H” imprinted on the fastener head. The stainless steel fasteners are identified by “HI” imprinted on the fastener head. Where applicable, the word “Hilti” is stamped on the steel washers. All fasteners are packaged in containers noting the fastener type, size, manufacturer’s name, and evaluation report number (ESR-1663).

7.2 The report holder’s contact information is the following:

**HILTI, INC.**  
**7250 DALLAS PARKWAY, SUITE 1000**  
**PLANO, TEXAS 75024**  
**(800) 879-8000**  
[www.hilti.com/](http://www.hilti.com/)

**TABLE 1—FASTENER DESCRIPTION AND APPLICATIONS<sup>1</sup>**

FASTENER	FASTENER DESCRIPTION	SHANK TYPE	SHANK DIAMETER (inch)	HEAD DIAMETER (inch)	MAXIMUM POINT LENGTH (inch)	MINIMUM EFFECTIVE SHANK LENGTH (inch)	FASTENER MATERIAL/ COATING	APPLICABLE BASE MATERIAL	APPLICABLE LOAD TABLES
X-ENP-19 L15	Powder-actuated Heavy Duty Fastener	Knurled, tapered	0.177	0.291	0.56	0.748	Carbon steel galvanized per ASTM B633, SC1, Type III	Steel	2
EDS ##	Powder-actuated Heavy Duty Fastener	Knurled, straight	0.177	0.390	0.43	See Footnote 2		Steel	2
DS ##	Powder-actuated Heavy Duty Fastener	Smooth, straight	0.177	0.390	0.43	See Footnote 2		Steel	2
X-C ##	Powder-actuated Standard Fastener	Knurled, straight	0.138	0.321	0.30	See Footnote 2		Concrete Conc.-filled deck	4, 5
X-C22P8TH	Powder-actuated Standard Fastener	Knurled, straight	0.138	0.321	0.30	0.807		Concrete Conc.-filled deck	4, 5, 6
X-C20THP	Powder-actuated Standard Fastener	Knurled, straight	0.138	0.321	0.30	0.728		CMU	7
X-W6	Powder-actuated 1/4-20 Threaded Stud	Smooth, straight	0.145	n/a	n/a	n/a		Concrete Conc.-filled deck	4, 5
W10	Powder-actuated 3/8-16 Threaded Stud	Smooth, straight	0.205	n/a	n/a	n/a		CMU	7
X-CR ##	Powder-actuated Stainless Steel Fastener	Smooth, straight	0.145	0.321	0.43	See Footnote 2		Concrete Conc.-filled deck	4, 5
X-R	Powder-actuated Stainless Steel Fastener	Smooth, straight	0.145	0.321	0.35	0.531		Stainless steel	Steel

For SI: 1 inch = 25.4 mm.

<sup>1</sup>## denotes numbers used in fastener designation to represent nominal fastener length in mm.

<sup>2</sup>When multiple lengths of a fastener are addressed, the minimum effective shank length can be calculated in terms of the designated length as (##-1) in mm and (##-1)/25.4 in inches.

**TABLE 2—ALLOWABLE LOADS FOR CARBON-STEEL LOW-VELOCITY FASTENERS DRIVEN INTO STEEL**<sup>1,2,3</sup>

FASTENER DESCRIPTION	FASTENER	SHANK DIAMETER (inch)	ALLOWABLE LOADS (lbf)									
			Steel Thickness (inch):		<sup>3</sup> / <sub>16</sub>		<sup>1</sup> / <sub>4</sub>		<sup>3</sup> / <sub>8</sub>		<sup>1</sup> / <sub>2</sub>	
Load Direction:			Tension	Shear	Tension	Shear	Tension	Shear	Tension	Shear	Tension	Shear
Heavy Duty Knurled Shank	X-ENP-19 L15 <sup>(4)</sup>	0.177	-	-	710 <sup>(6)</sup>	715 <sup>(6)</sup>	790 <sup>(7)</sup>	775	735 <sup>(8)</sup>	720 <sup>(9)</sup>	735	720
Heavy Duty Knurled Shank	EDS	0.177	305 <sup>(5)</sup>	615	625 <sup>(5)</sup>	870	715 <sup>(5)</sup>	870	890 <sup>(5)</sup>	960	-	-
Heavy Duty Smooth Shank	DS	0.177	365 <sup>(5)</sup>	725	580 <sup>(5)</sup>	725	695 <sup>(5)</sup>	725	735	860	-	-

For SI: 1 inch = 25.4 mm, 1 lbf = 4.45 N, 1 ksi = 6.89 MPa.

<sup>1</sup>Fasteners must be driven to where the point of the fastener fully penetrates through the steel base material, unless otherwise noted.

<sup>2</sup>Allowable load capacities are based on base steel with a minimum yield strength ( $F_y$ ) of 36 ksi and a minimum tensile strength ( $F_u$ ) of 58 ksi.

<sup>3</sup>Unless otherwise noted, allowable loads are applicable to static and seismic loads in accordance with Section 4.1.

<sup>4</sup>Values are based on installation through metal sheet material with a maximum thickness of 0.1345 inch. Point penetration is not necessary.

<sup>5</sup>For steel-to-steel connections designed in accordance with Section 4.1.4, the tabulated allowable load may be increased by a factor of 1.25, and the design strength may be taken as the tabulated allowable load multiplied by a factor of 2.0.

<sup>6</sup>Tabulated allowable load applies to static load conditions only. For seismic loading, allowable loads must be limited in accordance with Section 4.1.5, Item 3.

<sup>7</sup>Tabulated allowable load is applicable to static load conditions only. For seismic loading, the allowable load must be limited to the tabulated allowable static load multiplied by 0.80.

<sup>8</sup>Tabulated allowable load is applicable to static load conditions only. For seismic loads, the allowable load must be limited to the tabulated allowable static load multiplied by 0.68.

<sup>9</sup>Tabulated allowable load is applicable to static load conditions only. For seismic loads, the allowable load must be limited to the tabulated allowable static load multiplied by 0.95.

**TABLE 3—ALLOWABLE LOADS FOR STAINLESS STEEL LOW-VELOCITY FASTENERS DRIVEN INTO STEEL**<sup>1,2,3</sup>

FASTENER DESCRIPTION	FASTENER	SHANK DIAMETER (inch)	ALLOWABLE LOADS (lbf)									
			Steel Thickness (inch):		<sup>1</sup> / <sub>8</sub>		<sup>3</sup> / <sub>16</sub>		<sup>1</sup> / <sub>4</sub>		<sup>3</sup> / <sub>8</sub>	
Load Direction:			Tension	Shear	Tension	Shear	Tension	Shear	Tension	Shear	Tension	Shear
Stainless Steel Smooth Shank	X-CR X-R	0.145	-	-	460 <sup>(8)</sup>	460	615 <sup>(8)</sup>	500	-	-	-	-
Stainless Steel Smooth Shank	X-CR <sup>4,9</sup> X-R <sup>4,9</sup>	0.145	300 <sup>(5)</sup>	190	615 <sup>(8)</sup>	495	760 <sup>(8)</sup>	500	220 <sup>(5)</sup>	325 <sup>(6)</sup>	225 <sup>(7)</sup>	335 <sup>(7)</sup>

For SI: 1 inch = 25.4 mm, 1 lbf = 4.4 N, 1 ksi = 6.89 MPa.

<sup>1</sup>Fasteners must be driven to where the point of the fastener fully penetrates through the steel base material, unless otherwise noted.

<sup>2</sup>Unless otherwise noted, allowable load capacities are based on base steel with a minimum yield strength ( $F_y$ ) of 36 ksi and a minimum tensile strength ( $F_u$ ) of 58 ksi.

<sup>3</sup>Unless otherwise noted, allowable loads are applicable to static and seismic loads in accordance with Section 4.1.

<sup>4</sup>Allowable load capacity based on base steel with minimum yield strength ( $F_y$ ) of 50 ksi and minimum tensile strength ( $F_u$ ) of 65 ksi.

<sup>5</sup>The fastener must penetrate through the steel, but full fastener point penetration through the steel is not necessary.

<sup>6</sup>Fastener point penetration through the steel is not necessary, provided a minimum embedment depth of 0.354 inch is achieved.

<sup>7</sup>Fastener point penetration through the steel is not necessary, provided a minimum embedment depth of 0.470 inch is achieved.

<sup>8</sup>For steel-to-steel connections designed in accordance with Section 4.1.4, the tabulated allowable load may be increased by a factor of 1.25, and the design strength may be taken as the tabulated allowable load multiplied by a factor of 2.0.

<sup>9</sup>Tabulated loads apply to static load conditions only. For seismic loading, allowable loads must be limited in accordance with Section 4.1.5, Item 3.



**TABLE 4—ALLOWABLE LOADS FOR LOW-VELOCITY FASTENERS DRIVEN INTO NORMAL-WEIGHT CONCRETE<sup>1,2</sup>**

FASTENER DESCRIPTION	FASTENER	SHANK DIAMETER (inch)	MINIMUM EMBEDMENT DEPTH (inches)	ALLOWABLE LOADS (lbf)							
				Concrete Compressive Strength:		2,500 psi		4,000 psi		6,000 psi	
				Load Direction:		Tension (lbf)	Shear (lbf)	Tension (lbf)	Shear (lbf)	Tension (lbf)	Shear (lbf)
Standard Nail	X-C	0.138	3/4	45	75	65	105	95	195		
			1	85	150	160	200	105	270		
			1 1/4	130	210	270	290	165	325		
			1 1/2	175	260	270	360	—	—		
Drywall Track Nail	X-C22 P8 TH	0.138	3/4	55	130	90	170	100	200		
Heavy Duty Nail	DS	0.177	3/4	50	120	125	135	—	—		
			1	130	195	155	240	—	—		
			1 1/4	220	385	270	425	—	—		
			1 1/2	300	405	355	450	—	—		
1/4-20 Threaded Stud	X-W6	0.145	3/4	40	55	40	55	—	—		
			1	85	195	110	225	—	—		
3/8-16 Threaded Stud	W10	0.205	1	85	95	100	105	—	—		
			1 1/4	175	345	200	380	—	—		
			1 5/8	285	380	385	395	—	—		
Stainless Steel Nail	X-CR	0.145	3/4	30	40	65	40	—	—		
			1	55	185	120	190	100	170		
			1 1/4	110	290	125	300	120	440		
			1 1/2	265	405	350	450	—	—		

For SI: 1 inch = 25.4 mm, 1 psi = 6.89 kPa, 1 lbf = 4.45 N.

<sup>1</sup>Fasteners must not be driven until the concrete has reached the designated minimum compressive strength.

<sup>2</sup>The fasteners listed in the table above may be used for static load conditions and for the seismic load conditions described in Section 4.1.5, as applicable. The tabulated allowable loads apply to static load conditions. For seismic load conditions, the allowable loads must be limited in accordance with Section 4.1.5, Items 2 and 4, as applicable.

**TABLE 5—ALLOWABLE LOADS FOR LOW-VELOCITY FASTENERS DRIVEN INTO MINIMUM  $f'_c=3,000$  psi SAND-LIGHTWEIGHT CONCRETE<sup>1,4</sup>**

FASTENER DESCRIPTION	FASTENER	SHANK DIAMETER (inch)	MINIMUM EMBEDMENT DEPTH (inches)	ALLOWABLE LOADS (lbf)					
				Fastener Location:		Installed into Concrete		Installed Through Steel Deck Panel into Concrete <sup>2,3</sup>	
						Tension	Shear	Upper Flute	Lower Flute
Load Direction:				Tension	Shear	Tension	Tension	Shear	
Standard Nail	X-C	0.138	3/4	120	175	120	95	265	
			1	180	260	215	155	485	
			1 1/4	225	400	250	200	500	
			1 1/2	285	400	285	210	555	
Drywall Track Nail	X-C20 THP	0.138	5/8	55	110	-	45	285	
	X-C22 P8TH	0.138	3/4	120	220	120	95	260	
Heavy Duty Nail	DS <sup>5</sup>	0.177	3/4	100	200	-	-	200	
			1	180	360	-	180	405	
			1 1/4	300	520	-	-	515	
			1 1/2	450	680	-	325	625	
Stainless Steel Nail	X-CR	0.145	1	230	240	-	-	240	
			1 1/4	320	400	-	-	400	
			1 1/2	405	500	-	-	500	
1/4"-20 Threaded Stud	X-W6	0.145	3/4	125	185	125	115	185	
			1	175	185	160	180	185	
3/8"-16 Threaded Stud	W10	0.205	1	265	185	-	-	185	
			1 1/4	280	380	160	210	685	
			1 5/8	445	540	435	325	945	

For SI: 1 inch = 25.4 mm, 1 psi = 6.89 kPa, 1 lbf = 4.45 N.

<sup>1</sup>Fasteners must not be driven until the concrete has reached the designated minimum compressive strength.

<sup>2</sup>The steel deck panel profile must be 3-inch-deep composite floor deck panel, with a minimum 0.0329-inch base-metal thickness, a minimum yield strength of 33 ksi and a minimum tensile strength of 45 ksi. Lower and upper flute widths must be a minimum of 3 7/8 inches. Figure 2 shows the nominal flute dimensions, fastener locations and load orientations for the deck panel profile.

<sup>3</sup>Sand-lightweight concrete fill depth above top of steel deck panel must be a minimum of 3 1/4 inches.

<sup>4</sup>The fasteners listed in the table above may be used for static load conditions and for the seismic load conditions described in Section 4.1.5, as applicable. The tabulated allowable loads apply to static load conditions. For seismic load conditions, the allowable loads must be limited in accordance with Section 4.1.5, Items 2 and 4, as applicable.

<sup>5</sup>DS fasteners installed at 1 1/2-inch embedment through steel deck panel into the lower flute must be installed at a minimum distance of 6 inches from the edge of the floor deck panel.

**TABLE 6—ALLOWABLE LOADS FOR LOW-VELOCITY FASTENERS DRIVEN INTO MINIMUM  $f'_c = 3,000$  psi SAND-LIGHTWEIGHT CONCRETE-FILLED 1½-INCH-DEEP, B-DECK STEEL PANEL<sup>1,4</sup>**

FASTENER DESCRIPTION	FASTENER	SHANK DIAMETER (inch)	MINIMUM EMBEDMENT DEPTH (inch)	ALLOWABLE LOADS (lbf)		
				Installed Through Steel Deck Panel Into Concrete <sup>2,3</sup>		
				Upper Flute	Lower Flute	
				Tension	Tension	Shear
Drywall track nail	X-C22 P8 TH	0.138	¾	90	110	295
Standard nail	X-C	0.138	¾	80	80	315
			1	205	205	445

For SI: 1 inch = 25.4 mm, 1 psi = 6.89 kPa, 1 lbf = 4.45 N.

<sup>1</sup>Fasteners must not be driven until the concrete has reached the designated minimum compressive strength.

<sup>2</sup>Steel deck panel profiles are 1½-inch-deep, B-type deck panel with a minimum base-metal thickness of 0.0329 inch, and a minimum yield strength of 38 ksi and a minimum tensile strength of 45 ksi. Fasteners may be installed through steel deck panels having either normal or inverted orientations with minimum lower flute widths of 1¾ and 3½ inches, respectively. Fasteners must be placed at centerline of deck panel flutes. Figures 3 and 4 describe additional flute dimensions, fastener locations, and load orientations for both deck panel profiles.

<sup>3</sup>Sand-lightweight concrete fill above top of steel deck panel must be a minimum of 2½ inches.

<sup>4</sup>The fasteners listed in the table above may be used for static load conditions and for the seismic load conditions described in Section 4.1.5, as applicable. The tabulated allowable loads apply to static load conditions. For seismic load conditions, the allowable loads must be limited in accordance with Section 4.1.5, Items 2 and 4, as applicable.

**TABLE 7—ALLOWABLE LOADS FOR LOW-VELOCITY FASTENERS DRIVEN INTO CONCRETE MASONRY UNITS<sup>1,2,3,9</sup>**

FASTENER DESCRIPTION	FASTENER	SHANK DIAMETER (inch)	EMBEDMENT DEPTH (inch)	ALLOWABLE LOADS (lbf)											
				Masonry Type:				Hollow CMU				Grouted CMU			
				Fastener Location:				Face Shell <sup>4</sup>		Mortar Joint <sup>5</sup>		Face Shell <sup>4</sup>		Mortar Joint <sup>5</sup>	
Load Direction:				Tension	Shear <sup>6</sup>	Tension	Shear <sup>6</sup>	Tension	Shear <sup>6</sup>	Tension	Shear <sup>7</sup>	Tension	Shear <sup>6</sup>		
Standard Nail	X-C	0.138	1	40	85	15	50	85	85	45	85	115	175		
¼-20 Threaded Stud	X-W6	0.145	1	105	175	80	110	125	175	135	150	—	—		

For SI: 1 inch = 25.4 mm, 1 lbf = 4.45 N.

<sup>1</sup>Fasteners must be installed a minimum of 4 inches from the top, bottom and end of the wall.

<sup>2</sup>See Section 3.2.2 for CMU, mortar and grout requirements.

<sup>3</sup>No more than one low-velocity fastener may be installed in an individual CMU cell.

<sup>4</sup>Fastener must be located a minimum of 1½ inches from the mortar joints, center web and end web of the CMU.

<sup>5</sup>Fasteners must not be installed in the head joints. Fasteners installed in the bed joints must be installed a minimum of 8 inches from the end of the wall. Multiple fasteners in a bed joint must be spaced a minimum of 8 inches.

<sup>6</sup>Shear load can be in any direction.

<sup>7</sup>Shear direction must be horizontal along the CMU wall plane.

<sup>8</sup>Fastener located in center of grouted cell must be installed vertically.

<sup>9</sup>The fasteners listed in the table above may be used for static load conditions and for the seismic load condition described in Item 1 of Section 4.1.5.



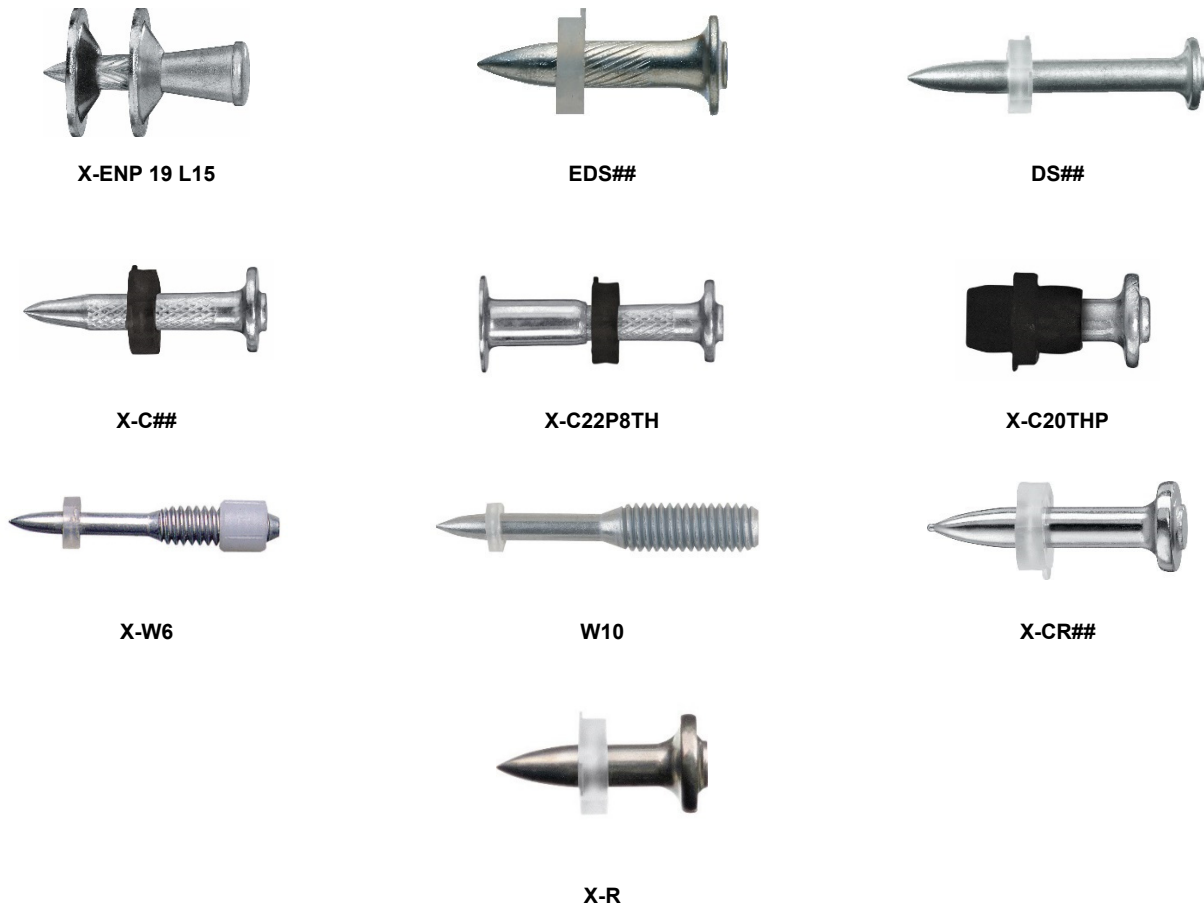

FIGURE 1—HILTI FASTENERS

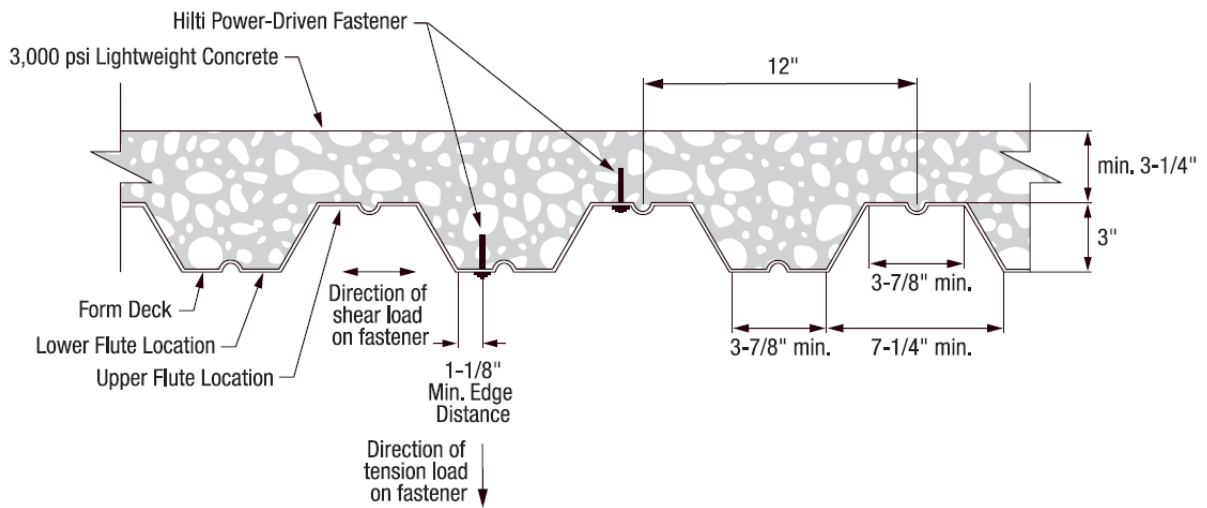
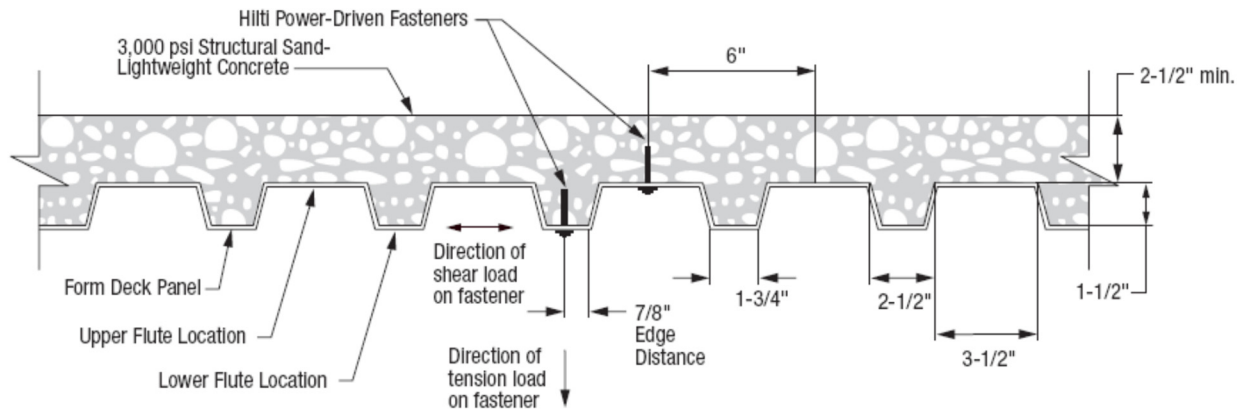
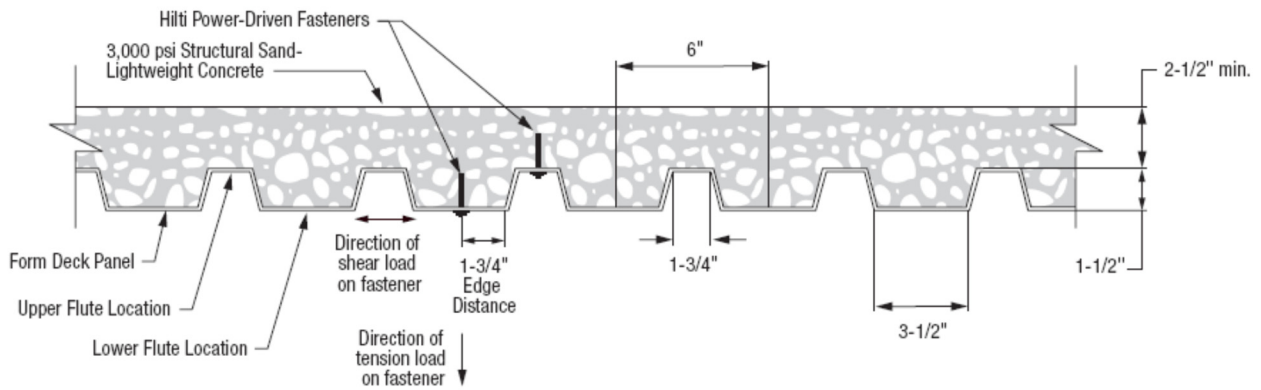

FIGURE 2—HILTI FASTENER LOCATIONS IN 3-INCH-DEEP COMPOSITE FLOOR DECK PANEL



**FIGURE 3—HILTI FASTENER LOCATIONS IN 1½-INCH-DEEP COMPOSITE FLOOR DECK PANEL, NORMAL DECK PANEL PROFILE ORIENTATION**



**FIGURE 4—HILTI FASTENER LOCATIONS IN 1½-INCH-DEEP COMPOSITE FLOOR DECK PANEL, INVERTED DECK PANEL PROFILE ORIENTATION**

For **SI**: 1 inch = 25.4 mm, 1 psi = 6895 Pa.

**DIVISION: 03 00 00—CONCRETE**  
**Section: 03 15 00—Concrete Accessories**  
**Section: 03 16 00—Concrete Anchors**

**DIVISION: 04 00 00—MASONRY**  
**Section: 04 05 19.16—Masonry Anchors**

**DIVISION: 05 00 00—METALS**  
**Section: 05 05 23—Metal Fastenings**

**DIVISION: 06 00 00—WOOD, PLASTICS AND COMPOSITES**  
**Section: 06 05 23—Wood, Plastic and Composite Fastenings**

**DIVISION: 09 00 00—FINISHES**  
**Section: 09 22 16.23—Fasteners**

**REPORT HOLDER:**

HILTI, INC.

**EVALUATION SUBJECT:**

HILTI LOW-VELOCITY POWER-ACTUATED FASTENERS

**1.0 REPORT PURPOSE AND SCOPE****Purpose:**

The purpose of this evaluation report supplement is to indicate that Hilti Low-Velocity Power-Actuated Fasteners, described in ICC-ES evaluation report [ESR-1663](#), have also been evaluated for compliance with the codes noted below as adopted by the Los Angeles Department of Building and Safety (LADBS).

**Applicable code editions:**

- 2023 *City of Los Angeles Building Code* (LABC)
- 2023 *City of Los Angeles Residential Code* (LARC)

**2.0 CONCLUSIONS**

The Hilti Low-Velocity Power-Actuated Fasteners, described in Sections 2.0 through 7.0 of the evaluation report [ESR-1663](#), comply with the LABC Chapter 19, 21, 22, 23, and the LARC, and are subjected to the conditions of use described in this supplement.

**3.0 CONDITIONS OF USE**

The Hilti Low-Velocity Power-Actuated Fasteners described in this evaluation report supplement must comply with all of the following conditions:

- All applicable sections in the evaluation report [ESR-1663](#).
- The design, installation, conditions of use and identification of the fasteners are in accordance with the 2021 *International Building Code*® (2021 IBC) provisions noted in the evaluation report [ESR-1663](#).
- The design, installation and inspection are in accordance with additional requirements of LABC Chapters 16 and 17, as applicable.

- Under the LARC, an engineered design in accordance with LARC Section R301.1.3 must be submitted.
- The allowable strength values listed in the evaluation report ESR-1663 are for the connection of the fasteners to normalweight concrete, lightweight concrete with or without metal deck, steel, and masonry. The connection between the fasteners and the connected members must be checked for capacity (which may govern).

This supplement expires concurrently with the evaluation report, reissued March 2023.

**DIVISION: 03 00 00—CONCRETE**

Section: 03 15 00—Concrete Accessories

Section: 03 16 00—Concrete Anchors

**DIVISION: 04 00 00—MASONRY**

Section: 04 05 19.16—Masonry Anchors

**DIVISION: 05 00 00—METALS**

Section: 05 05 23—Metal Fastenings

**DIVISION: 06 00 00—WOOD, PLASTICS AND COMPOSITES**

Section: 06 05 23—Wood, Plastic and Composite Fastenings

**DIVISION: 09 00 00—FINISHES**

Section: 09 22 16.23—Fasteners

**REPORT HOLDER:**

HILTI, INC.

**EVALUATION SUBJECT:**

HILTI LOW-VELOCITY POWER-ACTUATED FASTENERS

**1.0 REPORT PURPOSE AND SCOPE****Purpose:**

The purpose of this evaluation report supplement is to indicate that the Hilti Low-Velocity Power-Actuated Fasteners, addressed in ICC-ES evaluation report ESR-1663, have also been evaluated for compliance with the codes noted below.

**Applicable code editions:**

- 2020 Florida Building Code—Building
- 2020 Florida Building Code—Residential

**2.0 CONCLUSIONS**

The Hilti Low-Velocity Power-Actuated Fasteners, described in Sections 2.0 through 7.0 of the evaluation report ESR-1663, comply with the *Florida Building Code—Building* and the *Florida Building Code—Residential*. The design requirements shall be determined in accordance with the *Florida Building Code—Building* or the *Florida Building Code—Residential*, as applicable. The installation requirements noted in ICC-ES evaluation report ESR-1663 for the 2018 *International Building Code*® meet the requirements of the *Florida Building Code—Building* or the *Florida Building Code—Residential*, as applicable.

Use of the Hilti Low-Velocity Power-Actuated Fasteners has also been found to be in compliance with the High-Velocity Hurricane Zone provisions of the *Florida Building Code—Building* and the *Florida Building Code—Residential* under the following conditions:

- The use of Hilti Low-Velocity Power-Actuated Fasteners as a means of attachment for wood blocking, as defined in Section 2330.1.10 of the *Florida Building Code—Building*, is prohibited.
- The fasteners have not been evaluated for use as cast-in-place anchors for compliance with the High-Velocity Hurricane Zone provisions, and this use is outside the scope of this supplement.

For products falling under Florida Rule 61G20-3, verification that the report holder's quality assurance program is audited by a quality assurance entity approved by the Florida Building Commission for the type of inspections being conducted is the responsibility of an approved validation entity (or the code official, when the report holder does not possess an approval by the Commission).

This supplement expires concurrently with the evaluation report, reissued March 2023.