



- Compliance with International Codes
- Compliance with State Codes

ICC-ES Evaluation Report ESR-1788

Reissued May 2023

This report is subject to renewal May 2024.

DIVISION: 07 00 00—THERMAL AND MOISTURE PROTECTION

Section: 07 21 00—Thermal Insulation

Section: 07 22 00—Roof and Deck Insulation

Section: 07 25 00—Water-Resistive Barriers/Weather Barriers

REPORT HOLDER:

INSULFOAM, A DIVISION OF CARLISLE CONSTRUCTION MATERIALS, LLC

ADDITIONAL LISTEE:

THERMAL BUILDING CONCEPTS, LLC

EVALUATION SUBJECT:

INSULFOAM EXPANDED POLYSTYRENE (EPS) AND R-TECH™ AND THERMAL 3HT INSULATION BOARDS

1.0 EVALUATION SCOPE

1.1 Compliance with the following codes:

- 2021, 2018, 2015, 2012 and 2009 *International Building Code*® (IBC)
- 2021, 2018, 2015, 2012 and 2009 *International Residential Code*® (IRC)
- 2021, 2018, 2015, 2012 and 2009 *International Energy Conservation Code*® (IECC)
- 2013 *Abu Dhabi International Building Code* (ADIBC)[†]

[†]The ADIBC is based on the 2009 IBC. 2009 IBC code sections referenced in this report are the same sections in the ADIBC.

Properties evaluated:

- Physical properties
- Surface-burning characteristics
- Attic and crawl space installation
- Thermal resistance (R-values)
- Water-resistive barrier (R-TECH Board)

1.2 Evaluation to the following green codes and/or standards:

- 2022 California Green Building Standards Code (CALGreen), Title 24, Part 11

- 2020, 2015, 2012 and 2008 ICC 700 *National Green Building Standard*™ (ICC 700-2020, ICC 700-2015, ICC 700-2012 and ICC 700-2008)

Attributes verified:

See Section 3.4.

2.0 USES

Insulfoam Expanded Polystyrene (EPS) and R-TECH™ insulation boards are EPS foam plastic boards used as nonstructural thermal insulation in wall cavities or ceiling assemblies, door cavities, roof and as exterior perimeter insulation around concrete slab edges, on foundation walls or under flat concrete slab on grade construction, except in areas where the probability of termite exposure is “very heavy” as defined in 2021, 2018, 2015 and 2009 IBC Section 2603.8 (2012 IBC Section 2603.9) and IRC Section R318.4. The insulation may be used on the outside faces of exterior walls of Type V-B (IBC) construction, or structures constructed in accordance with the IRC. The insulation boards may be used on walls in attics and crawl spaces with no covering applied to the attic or crawl space side of the foam plastic, when these boards are installed in accordance with Section 4.2. The R-TECH™ One-Coat Stucco Boards may be used as an alternative to the water-resistive barriers specified in the IBC or IRC, when installed as set forth in Section 4.3.

Thermal 3HT Insulation boards are identical to R-Tech Insulation boards and may be used and installed in the same manner as R-Tech Insulation boards.

3.0 DESCRIPTION

3.1 EPS Board:

Insulfoam EPS board is available with flat faces and square edges in various lengths and widths and in thicknesses up to 6 inches (152 mm). The foam plastic boards are Type I, II, VIII or IX boards complying with ASTM C578, and having densities and thermal resistance values as shown in Table 1. The foam plastic boards have a flame-spread index not exceeding 25 and a smoke-developed index not exceeding 450 when tested in accordance with ASTM E84 (UL 723).

3.2 EIFS Grade (IEG) EPS Board:

IEG board is available with flat faces and square edges in various lengths and widths and in thicknesses up to 4 inches (102 mm). The foam plastic board is a Type I board complying with ASTM C578. The board has a minimum density of 0.90 pcf (14.4 kg/m³), and is used as a component

of exterior insulation and finish systems (EIFS). The foam plastic board has a flame-spread index not exceeding 25 and a smoke-developed index not exceeding 450 when tested in accordance with ASTM E84 (UL 723). The foam plastic IEG board has more restrictive requirements than the EPS board for conditioning, product dimensions, marking and packaging.

3.3 R-TECH™ Board:

R-TECH™ board is available with flat faces and square edges in various lengths and widths, and in thicknesses up to 5 inches (127 mm). The foam plastic boards are Type I, II, VIII or IX boards complying with ASTM C578. The boards have densities and thermal resistance values as shown in Table 1. The foam plastic boards consist of an EPS core with the faces laminated with polyethylene and polypropylene films. The foam plastic boards are manufactured in a fanfold or standard configuration. An optional reflective metalized film facer is also available. The foam plastic boards have a flame-spread index not exceeding 25 and a smoke-developed index not exceeding 450 when tested in accordance with ASTM E84 (UL 723).

3.4 R-TECH™ One-Coat Stucco Board:

R-TECH™ One-Coat Stucco Boards are available with flat faces or with nominally 1/2-inch-wide-by-1/4-inch-deep channels spaced a maximum of 12 inches (305 mm) on center on the back face of the board, with nominally 1.5-mil-thick plastic facers laminated to both sides of the board. The boards are produced in a 1-inch (25.4 mm) thickness and in the following configurations:

- Two or 4 feet wide by 8 feet long (610 or 1219 mm by 2438 mm) with either 1/2-by-1/2-inch (12.7 by 12.7 mm) shiplap joints or tongue-and-groove joints on the long edges.
- Forty-nine inches wide by 8 to 10 feet long (1245 mm by 2438 to 3048 mm) with shiplap joints on the long edge.
- Four feet wide by 8 to 10 feet long (1219 mm by 2438 to 3048 mm) with square edges.

See Figure 2 for additional details on the board edges. The foam plastic boards are Type I boards, complying with ASTM C578, and have a nominal density of 1 pcf (16.0 kg/m³). The foam plastic boards have a flame-spread index not exceeding 25 and a smoke-developed index not exceeding 450 when tested in accordance with ASTM E84 (UL 723).

The attributes of the R-TECH™ One-Coat Stucco Boards used as an alternative water-resistive barrier have been verified as conforming to the provisions of (i) CALGreen Section 5.407.1 and (ii) ICC 700-2020 Sections 602.1.8, 11.602.1.8, 1202.6 and 13.104.1.4; ICC 700-2015 Section 602.1.8, 11.602.1.8 and 12.6.602.1.8; ICC 700-2012 Section 602.1.8, 11.602.1.8 and 12.5.602.1.8; and ICC 700-2008 Section 602.9 for water-resistive barriers. Note that decisions on compliance for those areas rest with the user of this report. The user is advised of the project-specific provisions that may be contingent upon meeting specific conditions, and the verification of those conditions is outside the scope of this report. These codes or standards often provide supplemental information as guidance.

3.5 R-TECH™ Gable-Guard:

R-TECH™ Gable-Guard board is available with flat faces and square edges in 4-foot (1219 mm) widths and 8-foot (2438 mm), 10-foot (3048 mm) and 12-foot (3658 mm) lengths, and with a nominal thickness of 1/2 inch. The foam plastic boards are Type I boards complying with ASTM C578. The boards have a nominal density of 1 pcf

(16.0 kg/m³) and a nominal 1.5-mil polymeric facer laminated to both sides of the board, and a thermal resistance value as shown in Table 1. The foam plastic boards have a flame-spread index not exceeding 25 and a smoke-developed index not exceeding 450 when tested in accordance with ASTM E84 (UL 723).

3.6 Poly-Guard 136 Tape:

Poly-Guard 136 tape must be used with the R-TECH™ One-Coat Stucco Board when the board is used as an alternative water-resistive barrier as described in Section 4.3. The tape consists of a polyethylene backing with a rubber-based adhesive, and has a nominal thickness of 9.0 mils and a width of 2 inches (51 mm). The tape is supplied in 36-yard (32 918 mm) rolls.

4.0 INSTALLATION

4.1 General:

Installation of Insulfoam EPS™ and R-TECH™ insulation boards must comply with this report and the manufacturer's published installation instructions. The manufacturer's published installation instructions must be available at the jobsite at all times during installation.

Except as described in Section 4.2, the interior of the building must be separated from the insulation boards with an approved thermal barrier as required by IBC Section 2603.4 or IRC Section R316.4. The use of the insulation boards in areas of "very heavy" termite infestation probability must comply with 2021, 2018, 2015 and 2009 IBC Section 2603.8 (2012 IBC Section 2608.9) or IRC Section R318.4 when boards are used in structures regulated by the IRC. A vapor retarder must be installed, in accordance with 2021 and 2018 IBC Section 1404.3 (2015 and 2012 IBC Section 1405.3) or 2021, 2018, 2015 and 2012 IRC Section R702.7 (2009 IRC Section R601.3), as applicable. The insulation board may be applied to exterior faces of walls to a maximum thickness of 1 1/2 inches (38 mm), except insulation board thicknesses greater than 1 1/2 inches (38 mm) may be permitted if such installation is recognized in a current ICC-ES evaluation report on a wall covering. The attachment of finish materials over the insulation board must allow for a minimum 1-inch (25.4 mm) penetration of the fasteners into wood framing. Sheathing or a wall covering over the insulation must be structurally adequate to resist horizontal forces perpendicular to the wall. All walls must be braced in accordance with 2021, 2018 and 2015 IBC Section 2308.6 (2012 and 2009 IBC Section 2308.9.3) or IRC Section R602.10, as applicable.

Insulation boards must not be used as a nailing base for exterior siding materials. All nailing must be made through the insulation into the wall framing or structural sheathing as required by the siding manufacturer's instructions or the applicable code.

Use of insulation boards as roof insulation must be limited to installations recognized in a current ICC-ES evaluation report for the roof covering system.

4.2 Special Uses: Attics and Crawl Spaces:

Insulfoam EPS™, R-TECH™ and R-TECH™ Gable Guard insulation boards may be used in attics and crawl spaces without a covering being applied to the interior side of the foam plastic, provided all of the following conditions are met:

- Entry to the attic or crawl space is only to service utilities, and no storage is permitted.
- There are no interconnected attic or crawl space areas.
- Air in the attic or crawl space is not circulated to other parts of the building.

- d. Attic ventilation is provided when required by 2021 and 2018 IBC Section 1202.2 (2015, 2012 and 2009 IBC Section 1203.2) or IRC Section R806, as applicable.
- e. Under-floor (crawl space) ventilation is provided when required by 2021 and 2018 IBC Section 1202.4 (2015 IBC Section 1203.4, 2012 and 2009 IBC Section 1203.3) or IRC Section R408.1, as applicable.
- f. Insulfoam EPS™ or R-TECH™ insulation boards are limited to maximum nominal density of 1 pcf (16.0 kg/m³) and maximum thickness of 4 inches (102 mm), or maximum nominal density of 2 pcf (32.0 kg/m³) and maximum thickness of 2 inches (51 mm); or maximum nominal density of 1.5 pcf (24.0 kg/m³) and a maximum thickness of 2²/₃ inches (67.8 mm).
- g. Combustion air is provided in accordance with Section 701 of the *International Mechanical Code*.
- h. Insulfoam EPS™, R-TECH™ One-Coat Stucco Board and R-TECH™ Gable-Guard (attics only) insulation boards are limited to those manufactured from Styropek USA, Inc. (F95) BF and (F95) BFL ([ESR-1498](#)), BVPV Styrenics LLC M77 ([ESR-1798](#)), and Epsilyte, LLC Grade 54 ([ESR-1634](#)) beads; and are labeled as indicated in Section 7.0 and Figure 1.

4.3 Water-resistive Barrier:

4.3.1 General: When installed in accordance with this section, the R-TECH™ One-Coat Stucco Boards may be used as an alternative to Type I felt complying with ASTM D226. The boards must be covered with exterior plaster complying with IBC Section 2512 or IRC Section R703.6, or with one of the cementitious exterior wall coatings noted in Section 4.4 of this report.

The 2- or 4-foot-wide (610 and 1219 mm) R-TECH™ boards with tongue-and-groove joints on the long edges must be oriented horizontally, with the tongues facing upward. The 2- or 4-foot-wide (610 and 1219 mm) boards with shiplap joints, and the 48- or 49-inch-wide (1219 mm and 1245 mm) boards with square edges, must be oriented vertically. Shiplap joints must occur over framing and must overlap a minimum of 1/2 inch (12.7 mm).

The R-TECH™ One-Coat Stucco Boards must be installed directly to framing and fastened to exterior framing spaced a maximum of 24 inches (610 mm) on center, except where further limited by the requirements for the wall covering. Fasteners used to attach the boards to framing must be minimum 6d ring-shank nails and 15/16-inch-diameter (23.8 mm) plastic washers, or equivalent, spaced at 12 inches (305 mm) on center, or 1-inch-wide-crown (25.4 mm), 1³/₄-inch-long (45 mm), No. 16 gage staples spaced at 6 inches (152 mm) on center. Joints between boards, and corners created with the board, must be taped with Poly-Guard 136 polyethylene tape centered over the joint. R-TECH™ One-Coat Stucco Boards must be installed with a weep screed. See Figure 3 for installation details. R-TECH™ One-Coat Stucco Board used as a water-resistive barrier requires the use of self-adhering flashing, complying with the ICC-ES Acceptance Criteria for Flashing Materials (AC148), around penetrations as shown in Figure 4.

For exterior plaster complying with IBC Section 2512 or IRC Section R703.6, the length of the fasteners used to attach the lath must be proportionally increased based on the thickness of the R-TECH™ One-Coat Stucco Board. The increase in fastener length is to maintain penetration into framing that is equivalent to that of fasteners attaching the lath without insulation.

4.3.2 Penetrations: Flashing of flange-type window penetrations when R-TECH™ One-Coat Stucco Board is used as a water-resistive barrier must be accompanied by installation of flashing complying with AC148, completely covering the framing sill and extending a minimum of 6 inches (51 mm) up the sides of the opening and approximately 1¹/₂ inches (38 mm) beyond the face of the foam board at the front of the window opening. The flashing must be flush with the inside edge of the framing members on the inside of the wall. The flashing extending outside of the R-TECH™ One-Coat Stucco Board must be folded over the front face of the foam board. The flashing material must then be cut over the channels in the foam board and gently pushed down into the channels to allow for drainage. See Figure 4 for details.

Flashing of pipe penetrations must be accomplished by sealing around the pipe with flashing complying with AC148. Flashing of other penetrating items must be in accordance with the wall covering manufacturer's published installation instructions.

4.4 Cementitious Exterior Wall Coatings:

R-TECH™ One-Coat Stucco Board and R-TECH™ Gable-Gard may be used with cementitious exterior wall coatings when installed in accordance with this section (Section 4.4).

When used with a cementitious exterior wall coating recognized in an ICC-ES evaluation report, the R-TECH™ One-Coat Stucco Boards are an alternative to 1-inch-thick (25.4 mm), 1.5 pcf density (24.0 kg/m³), EPS foam plastic insulation specified in the ICC-ES evaluation report on the coating. When installed in accordance with Section 4.3 of this report, the R-TECH™ One-Coat Stucco Boards may be used as an alternative to Type I felt complying with ASTM D226. R-TECH™ One-Coat Stucco Boards used in conjunction with stucco systems where the R-TECH™ One-Coat Stucco Board is not the water-resistive barrier, are not required to be taped.

When used with ICC-ES recognized cementitious exterior wall coatings, the R-TECH™ Gable-Guard installed on attic wall framing is an alternative to 1-inch-thick (25.4 mm), 1.5 pcf density (24.0 kg/m³), EPS foam plastic insulation specified in the ICC-ES evaluation report on the coating. The R-TECH™ Gable-Guard must be installed, with a water-resistive barrier, directly to open framing with blocked insulation board joints, or must be installed over solid sheathing. Conditions in the evaluation report for the foam plastic insulation as part of the coating system, such as orientation, tongue-and-groove edges, square edges and taping, must be observed. Acceptable coating manufacturers and their respective evaluation reports for the code edition(s) referenced in the individual evaluation report, are as follows:

- Parex USA, Inc. [ESR-2564](#)
- StarRcoat, LLC [ESR-2099](#)
- Omega Products International, Inc. [ESR-1194](#)
- UltraKote Products, LLC. [ESR-1471](#)

5.0 CONDITIONS OF USE

The Insulfoam EPS boards described in this report comply with, or are suitable alternatives to what is specified in, those codes listed in Section 1.0 of this report, subject to the following conditions:

- 5.1** Installation must comply with this report, the manufacturer's published installation instructions and the applicable code. In the event of a conflict between

the manufacturer's published installation instructions and this report, this report must govern.

- 5.2 The insulation board must be covered with an approved exterior wall covering, including a water-resistive barrier complying with 2021 and 2018 IBC Section 1402.4 (2015, 2012 and 2009 IBC Section 1404.2) or IRC Section R703.2, as applicable.
- 5.3 The exterior wall covering spanning between wall framing members must provide the necessary structural resistance to wind and seismic forces.
- 5.4 Insulation boards must not be used as a nailing base for exterior siding materials. All nailing must be made through the insulation into the wall framing or structural sheathing as required by the siding manufacturer's instructions or the applicable code.
- 5.5 Except as noted in Section 4.2 of this report, the insulation boards must be separated from the interior of the building with a thermal barrier complying with IBC Section 2603.4 or IRC Section R316.4, as applicable.
- 5.6 A vapor retarder must be installed where required by 2021 and 2018 IBC Section 1404.3 (2015 and 2012 IBC Section 1405.3 or 2021, 2018, 2015 and 2012 IRC 702.7 (2009 IRC Section R601.3), as applicable.
- 5.7 Use of the foam plastic insulation in areas where the probability of termite infestation is "very heavy" must be in accordance with 2021, 2018, 2015 and 2009 IBC Section 2603.8 (2012 IBC Section 2603.9) or IRC Section R318.4.
- 5.8 For buildings in which the R-Tech One-Coat Stucco Board is used as a water-resistive barrier, all plans must be accompanied by drawings, consistent with the illustrations in this report, that include the following:
 - a. Installation at all openings, corners and insulation board terminations.
 - b. Location, configuration and method of sealing of joints between boards and at corners.
 - c. Typical cross section, showing all components of the wall.
 - d. Typical wall pipe and window penetrations.
- 5.9 Insulfoam insulation boards are produced at the locations listed in Table 2 of this report, under a quality control program with inspections by ICC-ES.

6.0 EVIDENCE SUBMITTED

- 6.1 Manufacturer's published installation instructions and descriptive literature.

- 6.2 Data in accordance with the ICC-ES Acceptance Criteria for Foam Plastic Insulation (AC12), dated June 2015 (editorially revised December 2020), including data in accordance with Appendix B.
- 6.3 Data in accordance with the ICC-ES Acceptance Criteria for Water-resistive Barriers (AC38), dated August 2016 (Editorially revised July 2021).
- 6.4 Data in accordance with the ICC-ES Acceptance Criteria for Foam Plastic Sheathing Panels Used as Weather-resistive Barriers (AC71), dated February 2003 (editorially revised March 2021).
- 6.5 Data in accordance with Section 3.1.7 of the ICC-ES Acceptance Criteria for Cementitious Exterior Wall Coatings (AC11), dated January 2013 (editorially revised October 2020).
- 6.6 Report containing results of testing performed in accordance with ASTM C578.
- 6.7 Report containing results of testing performed in accordance with UL 1715.

7.0 IDENTIFICATION

- 7.1 The insulation board packaging must bear a label with Insulfoam or Thermal Building Concepts, LLC; the manufacturing facility location; the date of manufacture; the evaluation report number (ESR-1788); the density; the flame-spread index (75 or less); and the smoke-developed index (450 or less).

In addition, insulation boards used for installations in attics and crawl spaces, as described in Section 4.2, must be identified as being produced from Styropek USA, Inc., BVPV Styrenics LLC or Epsilyte, LLC beads.

The Poly-Guard 136 polyethylene tape is identified with the product name.

- 7.2 The report holder's contact information is the following:

**INSULFOAM, A DIVISION OF CARLISLE
CONSTRUCTION MATERIALS, LLC
19727 57th AVENUE EAST
PUYALLUP, WASHINGTON 98375
(253) 271-3056
www.insulfoam.com**

- 7.3 The Additional Listee's contact information is the following:

**THERMAL BUILDING CONCEPTS, LLC
1366 ELON DRIVE
WAUKON, IOWA 52172**

TABLE 1—DENSITIES AND R-VALUES FOR BOARDS

EPS TYPE	NOMINAL DENSITY (pcf)	MINIMUM DENSITY (pcf)	R-VALUE PER INCH OF THICKNESS AT 75°F (ft ² -hr-°F/Btu)
I	1	0.9	3.6
VIII	1.25	1.15	3.8
II	1.5	1.35	4.0
IX	2	1.8	4.2

For SI: 1 inch = 25.4 mm, 1 pcf = 16.02 kg/m³, 1°F·ft²-hr/Btu = 0.176 m²-K/W, 1°F = 1.8°C+32.

TABLE 2—MANUFACTURING LOCATIONS

LOCATIONS OF INSULFOAM MANUFACTURING	LOCATION NUMBERS FOR PRODUCT IDENTIFICATION
Insulfoam 628 Western Drive Anchorage, Alaska 99501	I-62
Insulfoam 3401 West Cocopah Street Phoenix, Arizona 85009	I-65
Insulfoam 5635 Schaefer Avenue Chino, California 91710	I-64
Insulfoam 1155 Business Park Dr., Bldg. A Dixon, California 95620	I-63
Insulfoam 12601 East 33 rd Avenue—Unit 110 Aurora, Colorado 80011	I-42
Insulfoam 1057 Sunburst Lane Mead, Nebraska 68041	I-41
Insulfoam 4500 South Frontage Road Lakeland, Florida 33815	I-46
Insulfoam 19727 57 th Avenue East Puyallup, Washington 98375	I-61

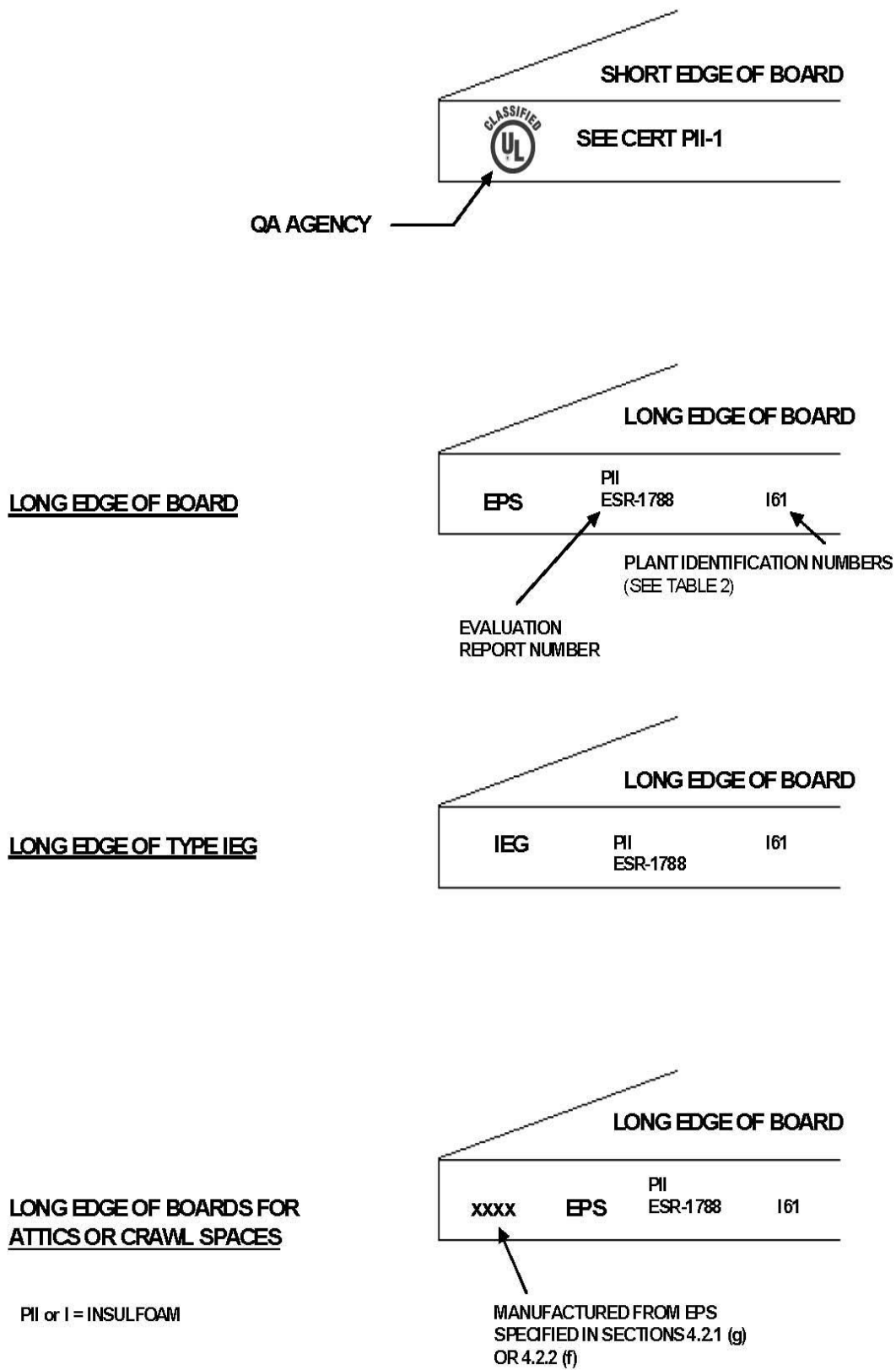

FIGURE 1—MARKINGS

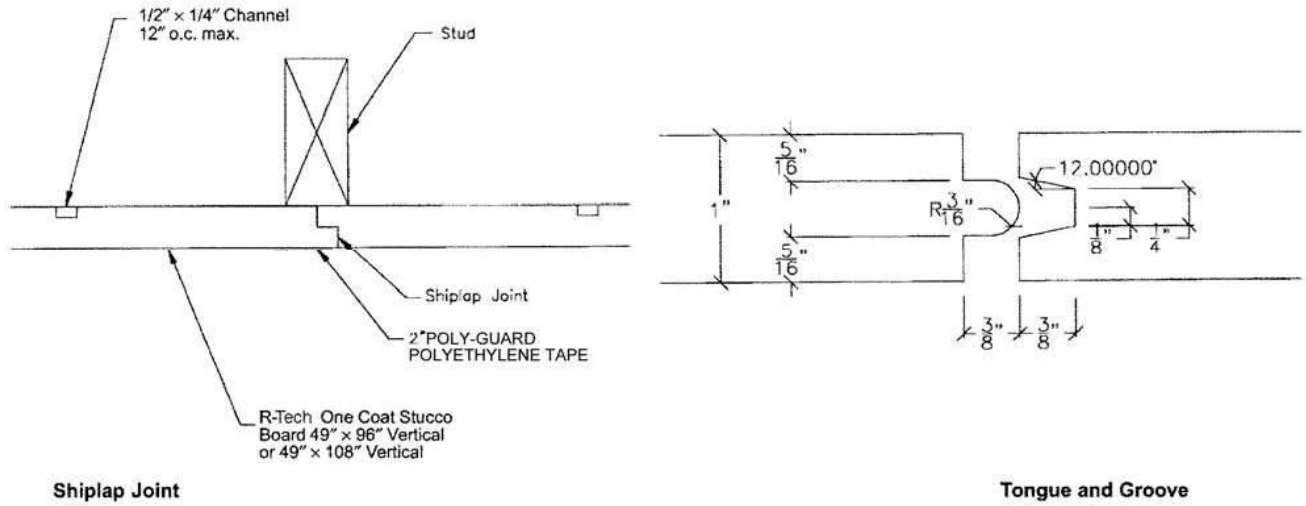

FIGURE 2—R-TECH EDGE DETAILS

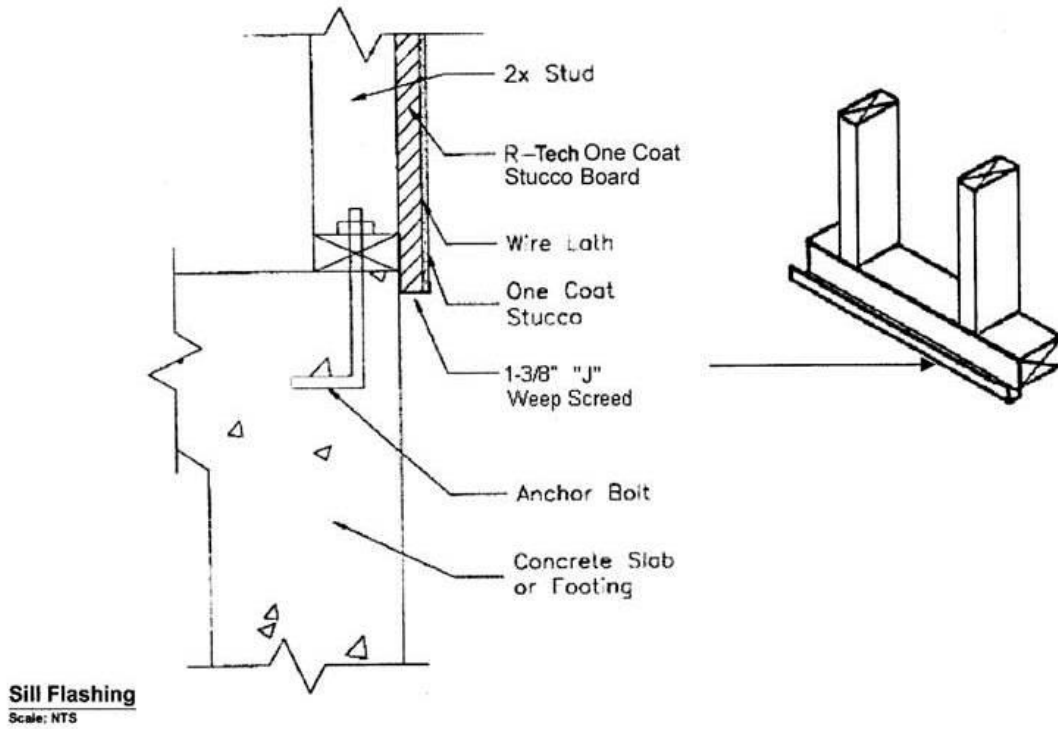

FIGURE 3—INSTALLATION DETAILS FOR R-TECH ONE-COAT STUCCO BOARD INSULATION USED AS A WEATHER-RESISTIVE BARRIER

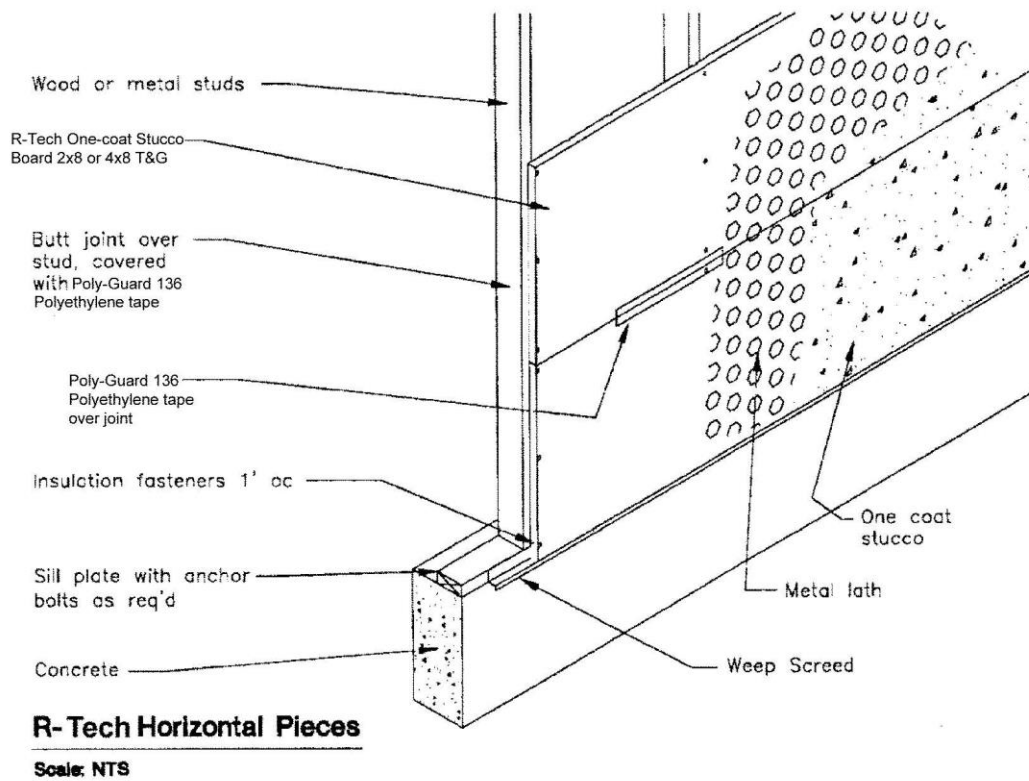
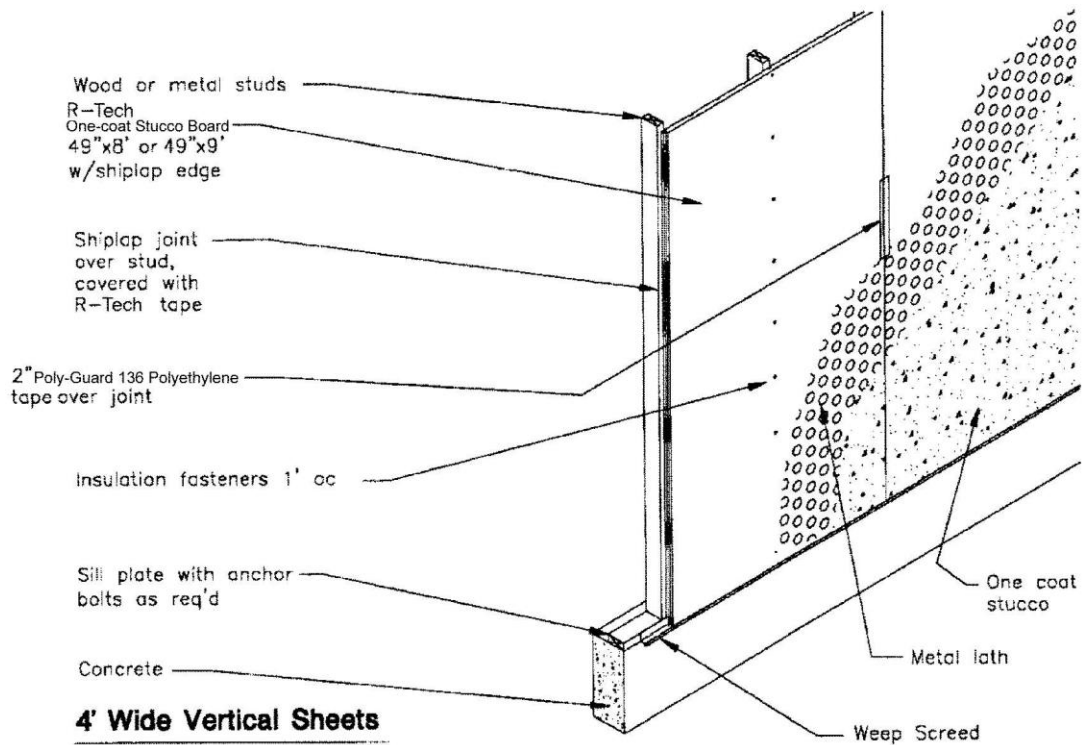

FIGURE 3—INSTALLATION DETAILS FOR R-TECH ONE-COAT STUCCO BOARD INSULATION USED AS A WEATHER-RESISTIVE BARRIER (Continued)

Typical Window Flashing Detail

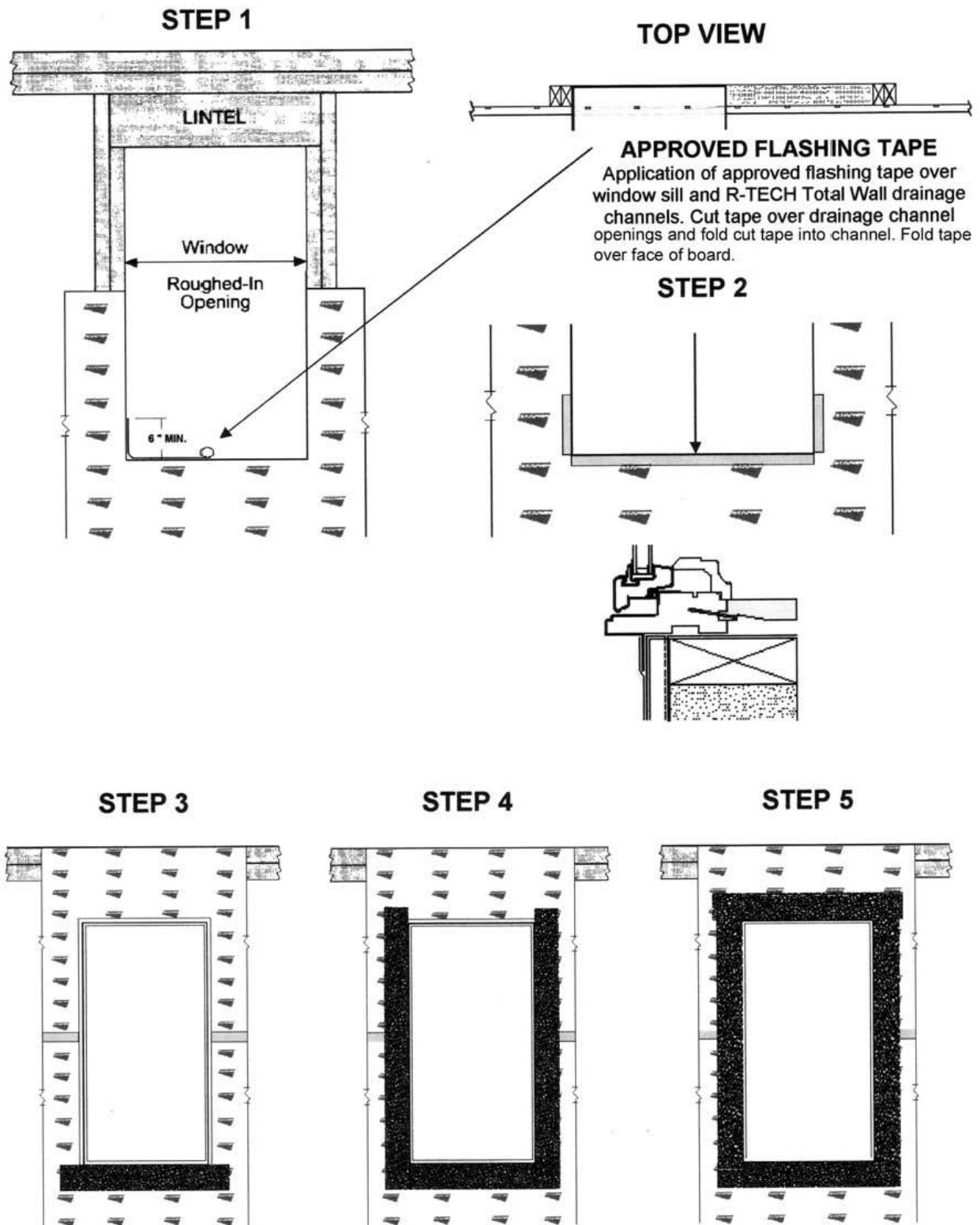

FIGURE 4—INSTALLATION DETAILS FOR R-TECH ONE-COAT STUCCO BOARD INSULATION USED AS A WEATHER-RESISTIVE BARRIER

Typical Window Flashing

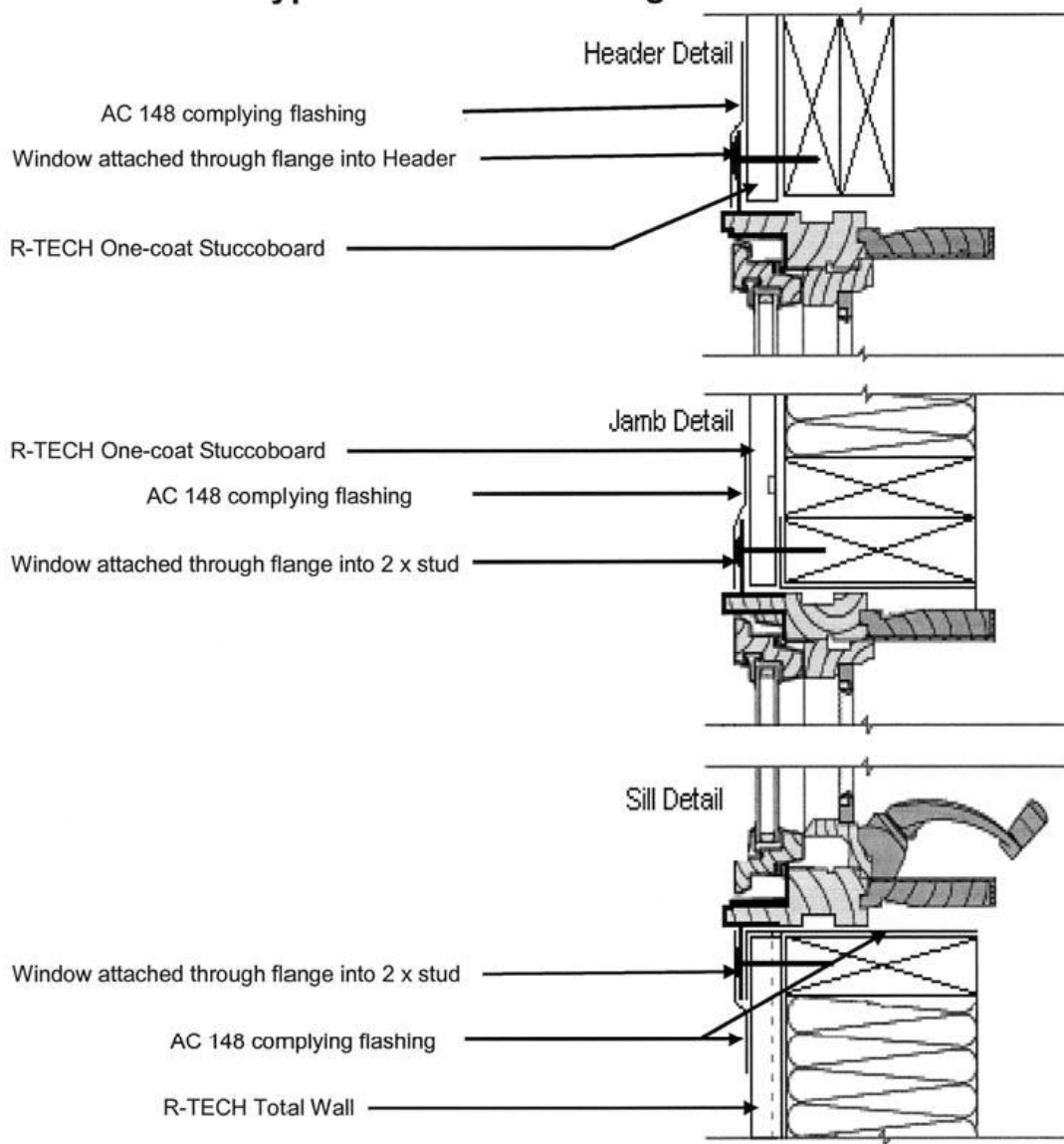

FIGURE 4—INSTALLATION DETAILS FOR R-TECH ONE-COAT STUCCO BOARD INSULATION USED AS A WEATHER-RESISTIVE BARRIER (Continued)

DIVISION: 07 00 00—THERMAL AND MOISTURE PROTECTION
Section: 07 21 00—Thermal Insulation
Section: 07 22 00—Roof and Deck Insulation
Section: 07 25 00—Water-Resistive Barriers/Weather Barriers

REPORT HOLDER:

INSULFOAM, A DIVISION OF CARLISLE CONSTRUCTION MATERIALS, LLC

EVALUATION SUBJECT:

INSULFOAM EXPANDED POLYSTYRENE (EPS) AND R-TECH™ AND THERMAL 3HT INSULATION BOARDS

1.0 REPORT PURPOSE AND SCOPE**Purpose:**

The purpose of this evaluation report supplement is to indicate that Insulfoam Expanded Polystyrene (EPS) and R-TECH™ and Thermal 3HT Insulation Boards, described in ICC-ES evaluation report ESR-1788, have also been evaluated for compliance with the codes noted below.

Applicable code editions:

- 2019 *California Building Code*® (CBC)

For evaluation of applicable chapters adopted by the California Office of Statewide Health Planning and Development (OSHPD) AKA: California Department of Health Care Access and Information (HCAI) and the Division of State Architect (DSA), see Sections 2.1.1 and 2.1.2 below.

- 2019 *California Residential Code*® (CRC)
- 2019 *California Energy Code*® (CEC)

2.0 CONCLUSIONS**2.1 CBC:**

The Insulfoam Expanded Polystyrene (EPS) and R-TECH™ and Thermal 3HT Insulation Boards, described in Sections 2.0 through 7.0 of the evaluation report ESR-1788, comply with the CBC, provided the design and installation are in accordance with the 2018 *International Building Code*® (IBC) provisions noted in the evaluation report.

2.1.1 OSHPD:

The applicable DSA Sections and Chapters of the CBC are beyond the scope of this supplement

2.1.2 DSA:

The applicable DSA Sections and Chapters of the CBC are beyond the scope of this supplement.

2.2 CRC:

The Insulfoam Expanded Polystyrene (EPS) and R-TECH™ and Thermal 3HT Insulation Boards, described in Sections 2.0 through 7.0 of the evaluation report ESR-1788, comply with the CRC, provided the design and installation are in accordance with the 2018 *International Residential Code*® (IRC) provisions noted in the evaluation report.

2.3 CEC:

The Insulfoam Expanded Polystyrene (EPS) and R-TECH™ and Thermal 3HT Insulation Boards, described in Sections 2.0 through 7.0 of the evaluation report ESR-1788, comply with the CEC, provided the design and installation are in accordance with the 2018 *International Building Code*® (IBC) provisions noted in the evaluation report.

2.3.1 Conditions of Use:

In accordance with Section 110.8 of the 2019 California Energy Code (CEC), verification of certification by the Department of Consumer Affairs, Bureau of Household Goods and Services, must be provided to the code official, demonstrating that the insulation conductive thermal performance is approved pursuant to the California Code of Regulations, Title 24, Part 12, Chapters 12-13, Article 3, "Standards for Insulating Materials." The certification must be verified with the DCA Bureau of Household Goods and Services using the following link to the bureau's Directory of Certified Insulation Materials: https://bhgs.dca.ca.gov/consumers/ti_directory.pdf

This supplement expires concurrently with the evaluation report, reissued May 2023.