

# ICC-ES Evaluation Report

ESR-2105

Reissued January 2024

This report also contains:



- FBC Supplement

Subject to renewal January 2025

- LABC Supplement

ICC-ES Evaluation Reports are not to be construed as representing aesthetics or any other attributes not specifically addressed, nor are they to be construed as an endorsement of the subject of the report or a recommendation for its use. There is no warranty by ICC Evaluation Service, LLC, express or implied, as to any finding or other matter in this report, or as to any product covered by the report.

Copyright © 2024 ICC Evaluation Service, LLC. All rights reserved.

<p><b>DIVISION: 06 00 00—</b> <b>WOOD, PLASTICS AND COMPOSITES</b></p> <p><b>Section: 06 05 23—</b> <b>Wood, Plastic, and Composite Fastenings</b></p>	<p><b>REPORT HOLDER:</b> <b>SIMPSON STRONG-TIE COMPANY INC.</b></p> 	<p><b>EVALUATION SUBJECT:</b> <b>SIMPSON STRONG-TIE STRAPS</b></p>	
--	---	--	---

## 1.0 EVALUATION SCOPE

### Compliance with the following codes:

- 2021, 2018, 2015 and 2012 [International Building Code® \(IBC\)](#)
- 2021, 2018, 2015 and 2012 [International Residential Code® \(IRC\)](#)

For evaluation for compliance with codes adopted by the [Los Angeles Department of Building and Safety \(LADBS\)](#), see [ESR-2105 LABC and LARC Supplement](#).

### Property evaluated:

Structural

## 2.0 USES

The Simpson Strong-Tie HST, LSTA, LSTI, MST, MSTA, MSTC, MSTI, and ST Series Straight Tie Straps; CMST and CS Series Coiled Tie Straps; MSTC16 Coiled Tie Strap; CTS218 Compression/Tension Straps; the MSTCB3 Pre-bent Tie Straps; and MDCTS, MDSS AND LDSS diaphragm chord tie straps are used to transfer between wood members wind or seismic loads resulting from the critical load combination in accordance with Section [1605.2](#) of the 2021 IBC (Section [1605.3](#) of the 2018, 2015 and 2012 IBC) where allowable stress equations are used. The straps may also be used in structures regulated by the IRC where an engineered design is submitted in accordance with IRC Section [R301.1.3](#).

## 3.0 DESCRIPTION

### 3.1 Straight Tie Straps:

The HST, LSTA, LSTI, MST, MSTA, MSTC, MSTI, and ST Series straight tie straps are supplied in manufacturer-designated lengths with prepunched holes for nails or bolts.

**3.1.1 ST Series:** The ST9, ST12, ST18, and ST 22 straps are 9 to 21<sup>5</sup>/<sub>8</sub> inches (229 to 549 mm) long and 1<sup>1</sup>/<sub>4</sub> inches (31.8 mm) wide. Each strap has unevenly spaced 1<sup>1</sup>/<sub>64</sub>-inch-diameter (4.3 mm) prepunched nail holes. See [Figure 1](#) for a drawing of the ST9, ST12, ST18, and ST 22 tie straps.

The ST292, ST2122, ST2215, ST6215, ST6224, and ST6236 straps are 9<sup>5</sup>/<sub>16</sub> to 33<sup>13</sup>/<sub>16</sub> inches (236.5 to 858.8 mm) long, and have a constant width of 1<sup>13</sup>/<sub>16</sub> inches (46 mm). The total strap width between longitudinal

edges is  $2^{1/16}$  inches (52.4 mm). Notches are  $9/32$  inch (7.1 mm) deep and are spaced  $1^{3/4}$  inches (44.5 mm) on center. Each longitudinal edge of an ST strap has a row of  $1^{1/64}$ -inch-diameter (4.3 mm) prepunched nail holes, spaced  $1^{3/4}$  inches (44.5 mm) on center. See [Figure 2](#) for a drawing of the ST292, ST2122, ST2215, ST6215, ST6224, and ST6236 tie straps.

The ST2115 strap is  $16^{5/16}$  inches (414.3 mm) long and  $3/4$  inch (19.1 mm) wide, and has one row of  $1^{1/64}$ -inch-diameter (4.3 mm), prepunched nail holes, spaced  $1^{5/8}$  inches (41.3 mm) on center. See [Figure 3](#) for a drawing of the ST2115 tie strap.

See [Table 1](#) for ST Series tie strap dimensions, fastener schedules, and allowable tension loads.

**3.1.2 HST Series:** The HST Series tie straps are either  $21^{1/4}$  or  $25^{1/2}$  inches (540 or 648 mm) long and from  $2^{1/2}$  to 6 inches (63.5 to 152 mm) wide. Each end of an HST strap has either three or six prepunched holes to accommodate  $5/8$ -inch- or  $3/4$ -inch-diameter (15.9 and 19.1 mm) bolts. The spacing and the location of the bolt holes in the strap length comply with the code-required bolt spacing and end distances. See [Figure 4](#) for a drawing of the HST Series tie straps. See [Table 2](#) for strap dimensions, fastener schedules, and allowable tension loads.

**3.1.3 MST Series:** The MST Series tie straps are 27 to 72 inches (686 to 1829 mm) long and  $2^{1/16}$  inches (52.4 mm) wide. Each strap has two rows of  $1^{1/64}$ -inch-diameter (4.3 mm) prepunched nail holes spaced  $1^{3/4}$  inches (43.7 mm) on center. Additionally, the straps have  $9/16$ -inch-diameter (14.3 mm) prepunched bolt holes spaced  $5^{1/4}$  inches (133.4 mm) on center. See [Figure 5](#) for a drawing of the MST Series tie straps. See [Table 2](#) for strap dimensions, fastener schedules, and allowable tension loads.

**3.1.4 LSTA and MSTA Series:** The LSTA and MSTA Series tie straps are 9 to 49 inches (229 to 1245 mm) long and  $1^{1/4}$  inches (32 mm) wide. Each strap has one row of staggered  $1^{1/64}$ -inch-diameter (4.3 mm) prepunched nail holes. The MSTA49 has  $5/32$ -inch-diameter (4.0 mm) prepunched nail holes. Longitudinal spacing (pitch) of consecutive holes is  $1^{1/2}$  inches (38 mm), and the transverse distance (gage) between staggered holes is  $9/16$  inch (14.3 mm). For the MSTA49, the longitudinal spacing (pitch) of consecutive holes is  $1^{17/32}$  inches (38.9 mm), and the transverse distance (gage) between staggered holes is  $1/2$  inch (12.7 mm). Both ends of every strap (except for the MSTA49) have one nail hole located between the last two staggered holes. See [Figure 6](#) for a drawing of the LSTA and MSTA Series tie straps. See [Table 3](#) for strap dimensions, fastener schedules, and allowable tension loads.

**3.1.5 LSTI Series:** The LSTI Series tie straps are either 49 or 73 inches (1244 or 1854 mm) long and  $3^{3/4}$  inches (95.3 mm) wide. Each strap has two rows of staggered  $5/32$ -inch-diameter (4.0 mm) prepunched nail holes. Longitudinal spacing (pitch) of consecutive holes in a row is 3 inches (76 mm), and the transverse distance (gage) between staggered holes in a row is  $3/8$  inch (9.5 mm). See [Figure 7](#) for a drawing of the LSTI Series tie straps. See [Table 3](#) for strap dimensions, fastener schedules, and allowable tension loads.

**3.1.6 MSTI Series:** The MSTI Series tie straps are  $2^{1/16}$  inches (52.4 mm) wide and from 26 to 72 inches (660 to 1829 mm) long. Each strap has three rows of  $5/32$ -inch-diameter (4.0 mm) prepunched nail holes spaced 3 inches (76 mm) on center. The holes in adjacent rows are offset by 1 inch (25.4 mm), resulting in one nail hole per inch of strap. See [Figure 8](#) for a drawing of the MSTI Series tie straps. See [Table 3](#) for strap dimensions, fastener schedules, and allowable tension loads.

**3.1.7 MSTC Series:** The MSTC Series tie straps are  $28^{1/4}$  to  $77^{3/4}$  inches (718 to 1975 mm) long and 3 inches (76.2 mm) wide. The straps have two rows of staggered prepunched holes spaced  $1^{1/2}$  inches (38.1 mm), measured from center-to-center of holes. On the nail head side of the strap, the holes are oblong and measure  $3/64$  inch wide by  $9/32$  inch long (5.1 mm by 7.1 mm), and are chamfered at 120 degrees. On the wood side of the strap, the holes are  $1^{1/64}$  inch wide by  $1/4$  inch long (4.4 mm by 6.4 mm). The long direction of the nail holes is perpendicular to the length of the strap. See [Figure 9](#) for a drawing of the MSTC Series tie straps. See [Table 3](#) for strap dimensions, fastener schedules, and allowable tension loads.

**3.1.8 MDCST and MDSS Series:** The MDCST and MDSS Medium Duty Diaphragm Chord Series tie straps are  $47^{1/2}$  inches (1207 mm) long and  $95^{1/2}$  inches (2426 mm) long, respectively, and  $5^{3/4}$  inches (146 mm) wide. These 14-gauge high capacity straps are designed to carry tension loads across a CLT floor or wall-panel joint. The MDCST straps have four rows of staggered prepunched holes spaced 1 inch (25.4 mm), measured from center-to-center of holes. The MDSS straps have two rows of holes spaced 2 inches (50.8 mm). The MDCST and MDSS use Simpson Strong-Tie Strong-Drive SDS Heavy-Duty Connector screws ([ESR-2236](#)). See [Figure 18](#) for a drawing of the MDCST and MDSS Series tie straps. See [Table 7](#) for strap dimensions, fastener schedules, and allowable tension loads.

**3.1.9 LDSS Series:** The LDSS Light Duty Diaphragm Chord series strap is 47½ inches (1207 mm) long and 3¾ inches (95.3 mm) wide. This 18-gauge strap is designed to carry tension loads across a CLT floor or wall-panel joint. The LDSS straps have two rows of staggered prepunched holes spaced 2 inches (50.8 mm) on center. See [Figure 18](#) for drawing of the LDSS strap. See [Table 7](#) for strap dimensions, fastener schedules and allowable tension loads.

### 3.2 Coiled Tie Straps:

The CS Series, CSHP Series, CMST Series, and CMSTC16 tie straps are supplied in coils and are cut to a specified length at the jobsite for engineered applications where the connected wood members are not abutting each other.

**3.2.1 CS Series:** The CS14, CS16, CS18, CS20, and CS22 straps are supplied as 100-, 150-, 200-, 250-, and 300-foot-long (30.5, 45.7, 61.0, 76.2, and 91.4 m) coils, respectively. The coiled steel is 1¼ inches (32 mm) wide and has two rows of prepunched, 5/32-inch-diameter (4.0 mm) holes. The longitudinal spacing of the holes in each row is 2¹/₁₆ inches (52.4 mm). See [Figure 11](#) for a drawing of the CS Series tie straps and [Figure 14](#) for a typical installation. See [Table 4](#) for strap dimensions, fastener schedules, and allowable tension loads.

**3.2.2 CMST Series:** The CMST12 strap is supplied as a 40-foot-long (12.19 m) coil, and the CMST14 strap is supplied as a 52½-foot-long (16.0 m) coil. The coiled steel is 3 inches (76 mm) wide and may have a crosswise weld. The coiled steel has two rows of prepunched round holes with 1¹/₆₄-inch (4.3 mm) diameters, and two rows of equilateral triangular holes sized to circumscribe an 1¹/₆₄-inch-diameter (4.3 mm) hole. The longitudinal spacing of the round and triangular holes in each row is 3.5 inches (88.9 mm). See [Figure 12](#) for a drawing of the CMST14 tie strap, and [Figure 14](#) for a typical installation. See [Table 4](#) for strap dimensions, fastener schedules, and allowable tension loads.

**3.2.3 CMSTC16:** The CMSTC16 strap is supplied as a 54-foot-long (16.46 m) coil. The width of the coiled steel is 3 inches (76.2 mm) and may have a crosswise weld. The coiled steel has two rows of staggered prepunched holes spaced 1½ inches (38.1 mm), measured from center-to-center of holes. On the nail head side of the strap, the holes are oblong and measure ¼ inch wide by 2¹/₆₄ inch long (6.4 mm by 8.3 mm), and are chamfered at 120 degrees. On the wood side of the strap, the holes are 1¹/₆₄ inch wide by ¼ inch long (4.4 mm by 6.4 mm). See [Figure 13](#) for a drawing of the CMSTC16 tie strap [Figure 14](#) for a typical installation. See [Table 4](#) for strap dimensions, fastener schedules, and allowable tension loads.

**3.2.4 CSHP Series:** The CSHP18 and CSHP20 straps are supplied as 75-foot-long (22.9 m) coils. The coiled steel is 1¾ inches (35 mm) wide and has two rows of prepunched, 0.136-inch-diameter (3.5 mm) holes. The longitudinal spacing of the holes in each row is 1¹⁵/₁₆ inches (49.2 mm). See [Figure 10](#) for a drawing of the CSHP Series tie straps and [Figure 14](#) for a typical installation. See [Table 4](#) for strap dimensions, fastener schedules, and allowable tension.

### 3.3 Compression/Tension Straps:

The CTS Series compression/tension strap is supplied in manufacturer-designated lengths with pre-punched holes for nails or Simpson Strong-Tie SD screws ([ESR-3046](#)). The straps have unique rolled edges and embossments allowing the straps to span gaps to partially restore compression as well as tension capacity to the notched or cut wood lumber framing.

The CTS218 is 1½ inches wide by 17⁷/₈ inches long (38 by 454 mm). The flat portion of the strap is 1¾ inches wide (35 mm) and the rolled edge is ¾ inch deep (9.5 mm). The strap has one row of staggered 5/32-inch-diameter (4.0 mm) prepunched fastener holes. Longitudinal spacing of consecutive holes is ½ inch (12.7 mm), and the transverse distance between staggered holes is ¾ inch (9.5 mm). There are 24 total prepunched holes, 12 holes on either side of a 6⁵/₁₆-inch-long gap (161 mm). A 5¾-inch-long-by-9/32-inch-deep (147 by 7.1 mm) embossment is centered in the gap and on the strap. See [Figure 15](#) for a drawing of the CTS218 strap and [Figure 16](#) for a typical installation. See [Table 5](#) for strap quantities, fastener schedule, and allowable tensile and compressive loads.

### 3.4 Pre-Bent Straps:

The MSTC48B3 and MSTC66B3Z are pre-bent straps designed to transfer tension load from an upper-story wood column or post to joists or a beam at the story below. The MSTC48B3 and MSTC66B3Z pre-bent tie straps are 44⁷/₈ and 62⁷/₈ inches (1140 and 1597 mm) long, respectively, and 3 inches (76.2 mm) wide. The straps have two rows of staggered prepunched holes spaced 1½ inches (38.1 mm), measured from center-to-center of holes. On the nail head side of the strap, the holes are oblong and measure 1³/₆₄ inch wide by

$\frac{9}{32}$  inch long (5.1 mm by 7.1 mm), and are chamfered at 120 degrees. On the wood side of the strap, the holes are  $\frac{11}{64}$  inch wide by  $\frac{1}{4}$  inch long (4.4 mm by 6.4 mm). The long direction of the nail holes is perpendicular to the length of the strap. See [Figure 17](#) for drawings of the MSTCB3 Series pre-bent tie straps. See [Table 6](#) for strap dimensions, fastener schedules, and allowable tension loads.

### 3.5 Materials:

**3.5.1 Steel:** The tie straps described in this report are manufactured from galvanized steel complying with [ASTM A653](#) SS designation, and minimum G90 zinc coating specifications, except for the HST3 and HST6 tie straps, which are manufactured from galvanized steel complying with [ASTM A1011](#), and the MST48, MST60, and MST72 tie straps, which are manufactured from galvanized steel complying with Simpson Strong-Tie's published specification for steel. Refer to the tables in this report for the minimum specified yield and tensile strengths,  $F_y$  and  $F_u$ , respectively, of the steel for each strap described in this report. Some models are available with a G185 continuous sheet galvanization in accordance with ASTM A653. The model numbers of tie straps with a G185 zinc coating are followed by the letter Z. Some models are available with a batch hot-dip galvanized coating with a minimum specified coating weight of 2.0 ounces of zinc per square foot of surface area (600 g/m<sup>2</sup>), total for both sides, in accordance with [ASTM A123](#). The model numbers of tie straps with a batch hot-dipped zinc coating are followed by the letters HDG.

The galvanized steel tie straps have the following minimum base-metal thicknesses:

GAGE	BASE-METAL THICKNESS (inch)
No. 3	0.2285
No. 7	0.1715
No. 10	0.1275
No. 12	0.0975
No. 14	0.0685
No. 16	0.0555
No. 18	0.0445
No. 20	0.0334

**3.5.2 Wood:** Wood members with which the tie straps are used must be either sawn lumber or engineered lumber having a minimum specific gravity of 0.50 (minimum equivalent specific gravity of 0.50 for engineered lumber), and having a maximum moisture content of 19 percent (16 percent for engineered lumber). The thickness (depth) of the wood main member must be equal to or greater than the length of the fasteners specified in the tables in this report, unless the reduced penetration effect on the load calculation per the applicable *National Design Specification for Wood Construction*<sup>®</sup> (NDS) and its *Supplement* is taken into account, or as required by wood member design, whichever is greater.

**3.5.3 Fasteners:** Nails must comply with [ASTM F1667](#) and have minimum bending yield strength,  $F_{yb}$ , of 90,000 psi (620.1 MPa). Bolts used with the MST and HST Series tie straps must as a minimum comply with [ASTM F1554-07a](#) Grade 36 and have a minimum bending yield strength of 45,000 psi (310.1 MPa). Strong-Drive SD screws are as described in ESR-3046. Strong-Drive SDS screws are as described in ESR-2236.

Fasteners used in contact with preservative-treated or fire-retardant-treated lumber must, as a minimum, comply with 2021 IBC Section [2304.10.6](#) [2018 and 2015 IBC Section [2304.10.5](#) and 2012 IBC Section [2304.9.5](#)]; and IRC Section [R317.3](#), as applicable. The lumber treater or report holder should be contacted for recommendations on minimum corrosion resistance and connection capacities of fasteners used with the specific proprietary preservative-treated or fire-retardant-treated lumber.

## 4.0 DESIGN AND INSTALLATION

### 4.1 Design:

Tabulated allowable tension loads in this evaluation report are based on allowable stress design and are the lesser of the tie strap steel strength or the connection strength. When connection strength governs, the tabulated allowable loads include the load duration factor,  $C_D$ , corresponding to design wind and seismic loads in accordance with the NDS.

Tabulated allowable loads are for tie straps connected to wood used under continuously dry interior conditions, and where sustained temperatures are 100°F (37.8°C) or less.

When tie straps are fastened to wood having a moisture content greater than 19 percent (16 percent for engineered wood products), or where wet service is expected, the allowable tension loads based on fastener lateral design values in this evaluation report must be adjusted by the wet service factor,  $C_M$ , specified in the NDS.

When tie straps are connected to wood that will experience sustained exposure to temperatures exceeding 100°F (37.7°C), the allowable loads in this evaluation report must be adjusted by the temperature factor,  $C_t$ , specified in the NDS.

Connected wood members must be analyzed for load-carrying capacity at the tie strap connection in accordance with the NDS.

#### 4.2 Installation:

Installation of the tie straps must be in accordance with this evaluation report and the manufacturer's published installation instructions. In the event of a conflict between this report and the manufacturer's published installation instructions, this report governs.

### 5.0 CONDITIONS OF USE:

The Simpson Strong-Tie Straight and Coiled Tie Straps described in this report comply with, or are suitable alternatives to what is specified in, those codes listed in Section 1.0 of this report, subject to the following conditions:

- 5.1 The tie straps must be manufactured, identified, and installed in accordance with this report and the manufacturer's published installation instructions. A copy of the instructions must be available at the jobsite at all times during installation.
- 5.2 Calculations showing compliance with this report must be submitted to the code official. The calculations must be prepared by a registered design professional where required by the statutes of the jurisdiction in which the project is to be constructed.
- 5.3 Adjustment factors noted in Section 4.1 of this report and the applicable codes must be considered, where applicable.
- 5.4 Connected wood members and fasteners must comply, respectively, with Sections 3.5.2 and 3.5.3 of this report.
- 5.5 Use of tie straps with preservative-treated and fire-retardant-treated lumber is outside the scope of this report. Use of fasteners with treated lumber must comply with Section 3.5.3 of this report.

### 6.0 EVIDENCE SUBMITTED

- 6.1 Data in accordance with the [ICC-ES Acceptance Criteria for Joist Hangers and Similar Devices \(AC13\)](#), dated October 2018 (editorially revised December 2020).
- 6.2 Structural calculations.
- 6.3 Quality documentation.

### 7.0 IDENTIFICATION

- 7.1 The ICC-ES mark of conformity, electronic labeling, or the evaluation report number (ESR-2523) along with the name, registered trademark, or registered logo of the report holder must be included in the product label.
- 7.2 Each tie strap described in this report is identified with a die-stamped label or an adhesive label, indicating the model number, and the number of an index evaluation report ([ESR-2523](#)) which contains a summary of all the product model numbers in the ICC-ES evaluation reports issued to this manufacturer.
- 7.3 The report holder's contact information is the following:

**SIMPSON STRONG-TIE COMPANY INC.**  
**5956 WEST LAS POSITAS BOULEVARD**  
**PLEASANTON, CALIFORNIA 94588**  
**(800) 999-5099**  
[www.strongtie.com](http://www.strongtie.com)  
[www.simpsonanchors.com](http://www.simpsonanchors.com)

TABLE 1—ALLOWABLE TENSION LOADS FOR THE ST SERIES TIE STRAPS

MODEL SERIES	MODEL NO.	TIE STRAP PROPERTIES				COMMON NAILS <sup>1</sup> (Total Quantity—Size)	ALLOWABLE TENSION LOADS <sup>2,3,4</sup> (lbs)
		Thickness (Gage No.)	Length (inches)	Minimum $F_y$ (ksi)	Minimum $F_u$ (ksi)		$C_D = 1.6$
ST	ST292	20	9 <sup>5</sup> / <sub>16</sub>	33	45	12–16d×2 <sup>1</sup> / <sub>2</sub>	1,260 <sup>(5)</sup>
	ST2122	20	12 <sup>13</sup> / <sub>16</sub>	40	55	16–16d×2 <sup>1</sup> / <sub>2</sub>	1,530 <sup>(5)</sup>
	ST2115	20	16 <sup>5</sup> / <sub>16</sub>	50	65	10–16d×2 <sup>1</sup> / <sub>2</sub>	660 <sup>(5)</sup>
	ST2215	20	16 <sup>5</sup> / <sub>16</sub>	50	65	20–16d×2 <sup>1</sup> / <sub>2</sub>	1,875 <sup>(5)</sup>
	ST6215	16	16 <sup>5</sup> / <sub>16</sub>	33	45	20–16d×2 <sup>1</sup> / <sub>2</sub>	2,090 <sup>(5)</sup>
	ST6224	16	23 <sup>5</sup> / <sub>16</sub>	40	55	28–16d×2 <sup>1</sup> / <sub>2</sub>	2,535 <sup>(5)</sup>
	ST6236	14	33 <sup>13</sup> / <sub>16</sub>	50	65	40–16d×2 <sup>1</sup> / <sub>2</sub>	3,845 <sup>(5)</sup>
	ST9	16	9	33	45	8–16d×2 <sup>1</sup> / <sub>2</sub>	885
	ST12	16	11 <sup>5</sup> / <sub>8</sub>	33	45	10–16d×2 <sup>1</sup> / <sub>2</sub>	1,105
	ST18	16	17 <sup>3</sup> / <sub>4</sub>	33	45	14–16d×2 <sup>1</sup> / <sub>2</sub>	1,420 <sup>(5)</sup>
ST22	16	21 <sup>5</sup> / <sub>8</sub>	33	45	18–16d×2 <sup>1</sup> / <sub>2</sub>	1,420 <sup>(5)</sup>	

For SI: 1 inch = 25.4 mm, 1 lbf = 4.45 N.

<sup>1</sup>Quantity of fasteners is the minimum number of common nails required to achieve the tabulated allowable loads. One half of the tabulated quantity must be installed in each wood member forming the connection. Fasteners must comply with Section 3.5.3 of this report.

<sup>2</sup>Allowable tension loads are based on the steel straps connected to wood members having an assigned or equivalent minimum specific gravity of 0.50.

<sup>3</sup>Allowable tension loads are the lesser of the tie strap steel strength or the connection strength.

<sup>4</sup>Tabulated allowable tension loads are governed by connection strength, unless noted otherwise. Connection strength is derived by multiplying the number of nails by the minimum value from the yield mode equations in Section 12.3.1 from the 2018 and 2015 NDS and Section 11.3.1 from the 2012 NDS, where the side member (i.e., the steel tie strap) dowel bearing strength,  $F_{ds}$ , is equal to  $2.2F_u/C_D$ , where  $C_D$  equals 1.6 as shown in the table, and where  $F_u$  equals the minimum specified tensile strength value of the steel shown in the table. The tabulated allowable tension loads governed by connection strength have been multiplied by the load duration factor,  $C_D$ , noted in the table, and are not permitted to be adjusted for other load durations.

<sup>5</sup>The tabulated allowable tension load is governed by steel strength, and does not include a one-third stress increase or the load duration factor,  $C_D$ . The steel strength is the least of yielding at the gross section of the strap, the fracture in the net section away from the connection, and fracture at the connection in accordance with Section C2 of AISI S100-16/S1-18 and S2-20 (2021 IBC), Section C2 of AISI S100-16 (2018 IBC), AISI S100-12 (2015 IBC), Section C2 of AISI S100-07/S2-10 (2012 IBC).

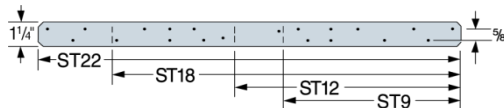

FIGURE 1—ST SERIES TIE STRAPS

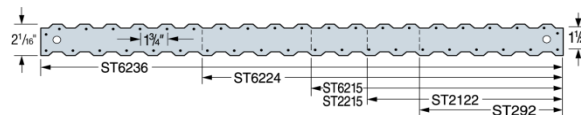

FIGURE 2—ST SERIES TIE STRAPS

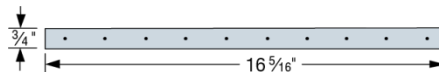

FIGURE 3—ST2115 TIE STRAP

TABLE 2—ALLOWABLE TENSION LOADS FOR THE HST AND MST SERIES TIE STRAPS

MODEL SERIES	MODE NO.	TIE STRAP PROPERTIES				FASTENERS <sup>1</sup> (Quantity–Size)		ALLOWABLE TENSION LOADS <sup>2,3,4,5</sup> (lbs)			
		Thick. (Gage No.)	Length (in.)	Min. $F_v$ (ksi)	Min. $F_u$ (ksi)	COMMON Nails	Bolts	$C_D = 1.6$			
								Nails	Bolts		
									Wood Member Thickness (in.)		
3	3 1/2	5 1/2									
HST	HST2	7	21 1/4	33	45	—	6–5/8"	—	5,280	5,260	5,220
	HST5	7	21 1/4	33	45	—	12–5/8"	—	10,680	10,650	10,595
	HST3	3	25 1/2	33	52	—	6–3/4"	—	6,795	7,625	7,650
	HST6	3	25 1/2	33	52	—	12–3/4"	—	13,760	15,395	15,425
MST	MST27	12	27	40	55	30–16dx2 1/2	4–1/2"	3,700	2,180	2,175	2,165
	MST37	12	37 1/2	40	55	42–16dx2 1/2	6–1/2"	5,070	3,075	3,060	3,030
	MST48	12	48	42	56	50–16dx2 1/2	8–1/2"	5,310 <sup>(6)</sup>	3,695 <sup>(6)</sup>	3,695 <sup>(6)</sup>	3,675
	MST60	10	60	42	56	68–16dx2 1/2	10–1/2"	6,730 <sup>(6)</sup>	4,670	4,605	4,490
	MST72	10	72	42	56	68–16dx2 1/2	10–1/2"	6,730 <sup>(6)</sup>	4,670	4,605	4,490

For SI: 1 inch = 25.4 mm, 1 lbf = 4.45 N.

<sup>1</sup>Quantity of fasteners is the total number of common nails or bolts, but not both, required to achieve the tabulated allowable loads. One half of the tabulated quantity must be installed in each wood member forming the connection. Fasteners must comply with Section 3.5.3 of this report.

<sup>2</sup>Allowable tension loads for nailed and bolted connections are not cumulative.

<sup>3</sup>Allowable tension loads are based on the steel straps connected to wood members having an assigned or equivalent minimum specific gravity of 0.50.

<sup>4</sup>Allowable tension loads are the lesser of the tie strap steel strength or the connection strength.

<sup>5</sup>Tabulated allowable tension loads are governed by connection strength, unless noted otherwise. Connection strength is derived by multiplying the number of fasteners by the minimum value from the yield mode equations in Section 12.3.1. from the 2018 and 2015 NDS and Section 11.3.1 from the 2012 NDS, where the dowel bearing strength,  $F_{es}$ , of the side member (i.e., the steel tie strap) is equal to  $2.2F_u/C_D$  for nailed and bolted connections, where the load duration factor,  $C_D$ , equals 1.6 as shown in the table, and where the minimum specified tensile strength,  $F_u$  of the steel strap is as shown in the table. For bolted connections, the tabulated allowable tension loads include the load duration factor,  $C_D$ , noted in the table, and the applicable group action factor,  $C_g$ .

<sup>6</sup>The tabulated allowable tension load is governed by steel strength, and does not include a one-third stress increase or the load duration factor,  $C_D$ . The steel strength is the least of yielding at the gross section of the strap, the fracture in the net section away from the connection, and fracture at the connection in accordance with Section C2 of AISI S100-16/S1-18 and S2-20 (2021 IBC), Section C2 of AISI S100-16 (2018 IBC), AISI S100-12 (2015 IBC), Section C2 of AISI S100-07/S2-10 (2012 IBC)..

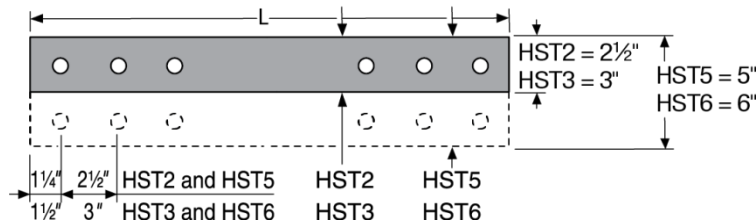

FIGURE 4—HST SERIES TIE STRAP

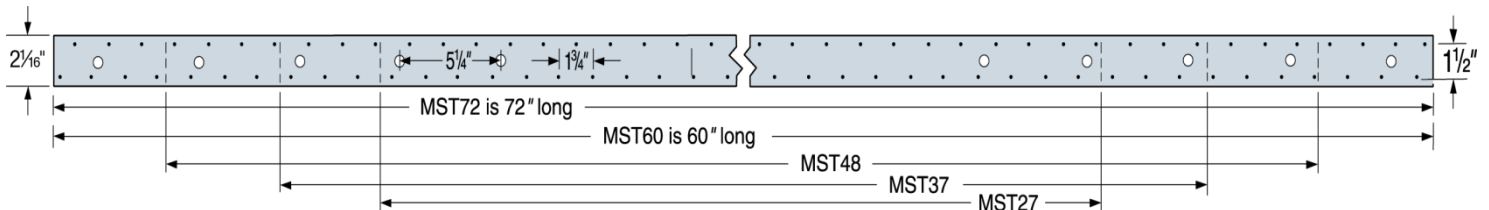

FIGURE 5—MST SERIES TIE STRAP

TABLE 3—ALLOWABLE TENSION LOADS FOR THE LSTA, MSTA, LSTI, AND MSTI SERIES TIE STRAPS

MODEL SERIES	MODEL NO.	TIE STRAP PROPERTIES				NAILS <sup>1</sup> (Total Quantity–Size)	ALLOWABLE TENSION LOADS <sup>2,3,4</sup> (lbs)
		Thickness (Gage No.)	Length (inches)	Min. $F_y$ (ksi)	Min. $F_u$ (ksi)		$C_D = 1.6$
LSTA	LSTA9	20	9	50	65	8–10dx2 <sup>1</sup> / <sub>2</sub> common	740
	LSTA12	20	12	50	65	10–10dx2 <sup>1</sup> / <sub>2</sub> common	925
	LSTA15	20	15	50	65	12–10dx2 <sup>1</sup> / <sub>2</sub> common	1,110
	LSTA18	20	18	50	65	14–10dx2 <sup>1</sup> / <sub>2</sub> common	1,235 <sup>(5)</sup>
	LSTA21	20	21	50	65	16–10dx2 <sup>1</sup> / <sub>2</sub> common	1,235 <sup>(5)</sup>
	LSTA24	20	24	50	65	18–10dx2 <sup>1</sup> / <sub>2</sub> common	1,235 <sup>(5)</sup>
	LSTA30	18	30	50	65	22–10dx2 <sup>1</sup> / <sub>2</sub> common	1,640 <sup>(5)</sup>
	LSTA36	18	36	50	65	24–10dx2 <sup>1</sup> / <sub>2</sub> common	1,640 <sup>(5)</sup>
MSTA	MSTA9	18	9	50	65	8–10dx2 <sup>1</sup> / <sub>2</sub> common	750
	MSTA12	18	12	50	65	10–10dx2 <sup>1</sup> / <sub>2</sub> common	940
	MSTA15	18	15	50	65	12–10dx2 <sup>1</sup> / <sub>2</sub> common	1,130
	MSTA18	18	18	50	65	14–10dx2 <sup>1</sup> / <sub>2</sub> common	1,315
	MSTA21	18	21	50	65	16–10dx2 <sup>1</sup> / <sub>2</sub> common	1,505
	MSTA24	18	24	50	65	18–10dx2 <sup>1</sup> / <sub>2</sub> common	1,640 <sup>(5)</sup>
	MSTA30	16	30	50	65	22–10dx2 <sup>1</sup> / <sub>2</sub> common	2,050 <sup>(5)</sup>
	MSTA36	16	36	50	65	26–10dx2 <sup>1</sup> / <sub>2</sub> common	2,050 <sup>(5)</sup>
	MSTA49	16	49	50	65	26–10dx2 <sup>1</sup> / <sub>2</sub> common	2,020 <sup>(5)</sup>
LSTI	LSTI49	18	49	40	55	32–10dx1 <sup>1</sup> / <sub>2</sub> common	2,970
	LSTI73	18	73	40	55	48–10dx1 <sup>1</sup> / <sub>2</sub> common	4,205 <sup>(5)</sup>
MSTI	MSTI26	12	26	40	55	26–10dx1 <sup>1</sup> / <sub>2</sub> common	2,745
	MSTI36	12	36	40	55	36–10dx1 <sup>1</sup> / <sub>2</sub> common	3,800
	MSTI48	12	48	40	55	48–10dx1 <sup>1</sup> / <sub>2</sub> common	5,070
	MSTI60	12	60	40	55	60–10dx1 <sup>1</sup> / <sub>2</sub> common	5,070 <sup>(5)</sup>
	MSTI72	12	72	40	55	72–10dx1 <sup>1</sup> / <sub>2</sub> common	5,070 <sup>(5)</sup>
MSTC	MSTC28	16	28 <sup>1</sup> / <sub>4</sub>	50	65	36–16d sinker	3,460
	MSTC40	16	40 <sup>1</sup> / <sub>4</sub>	50	65	52–16d sinker	4,735 <sup>(5)</sup>
	MSTC52	16	52 <sup>1</sup> / <sub>4</sub>	50	65	62–16d sinker	4,735 <sup>(5)</sup>
	MSTC66	14	65 <sup>3</sup> / <sub>4</sub>	50	65	76–16d sinker	5,850 <sup>(5)</sup>
	MSTC78	14	77 <sup>3</sup> / <sub>4</sub>	50	65	76–16d sinker	5,850 <sup>(5)</sup>

For SI: 1 inch = 25.4 mm, 1 lbf = 4.45 N.

<sup>1</sup>Total fasteners are the minimum number of nails required to achieve the tabulated allowable loads. One half of the total must be installed in each wood member forming the connection. Fasteners must comply with Section 3.5.3 of this report.

<sup>2</sup>Allowable tension loads are based on the steel straps connected to wood members having an assigned or equivalent minimum specific gravity of 0.50.

<sup>3</sup>Allowable tension loads are the lesser of the tie strap steel strength or the connection strength.

<sup>4</sup>Tabulated allowable tension loads are governed by connection strength, unless noted otherwise. Connection strength is derived by multiplying the number of nails by the minimum value from the yield mode equations in Section 12.3.1 from the 2018 and 2015 NDS and Section 11.3.1 from the 2012 NDS, where the side member (i.e., the steel tie strap) dowel bearing strength,  $F_{es}$ , is equal to  $2.2F_u/C_D$ , where the load duration factor,  $C_D$ , equals 1.6 as shown in the table, and where the minimum specified tensile strength,  $F_u$ , of the steel strap is as shown in the table. The tabulated allowable tension loads governed by connection strength have been multiplied by the load duration factor,  $C_D$ , noted in the table.

<sup>5</sup>The tabulated allowable tension load is governed by steel strength, and does not include a one-third stress increase or the load duration factor,  $C_D$ . The steel strength is the least of yielding at the gross section of the strap, the fracture in the net section away from the connection, and fracture at the connection in accordance with Section C2 of AISI S100-16/S1-18 and S2-20 (2021 IBC), Section C2 of AISI S100-16 (2018 IBC), AISI S100-12 (2015 IBC), Section C2 of AISI S100-07/S2-10 (2012 IBC).



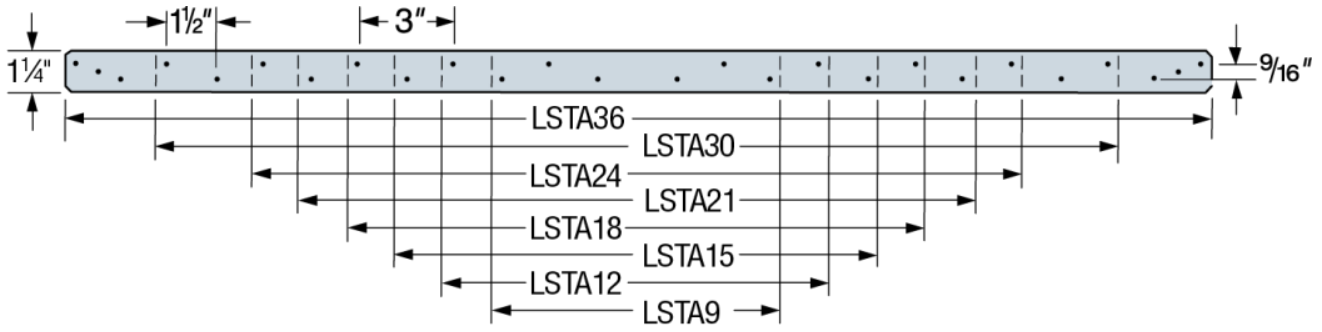

FIGURE 6—LSTA SERIES (MSTA SERIES SIMILAR) TIE STRAP

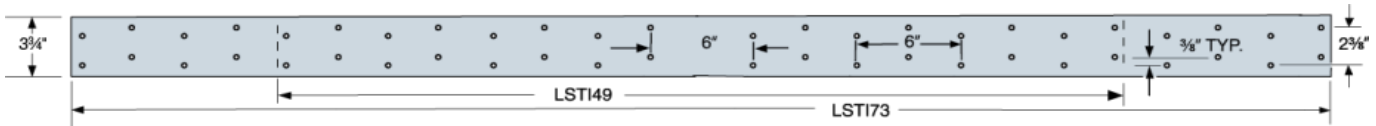

FIGURE 7—LSTI SERIES TIE STRAP

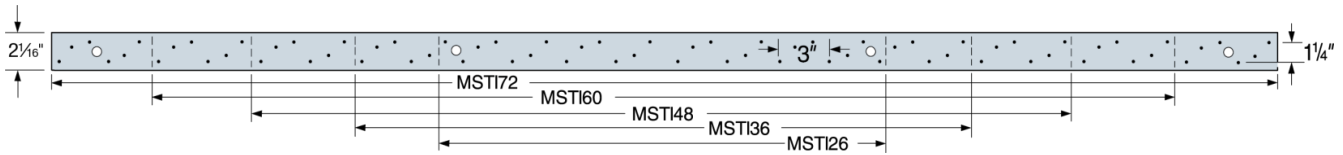

FIGURE 8—MSTI SERIES TIE STRAP

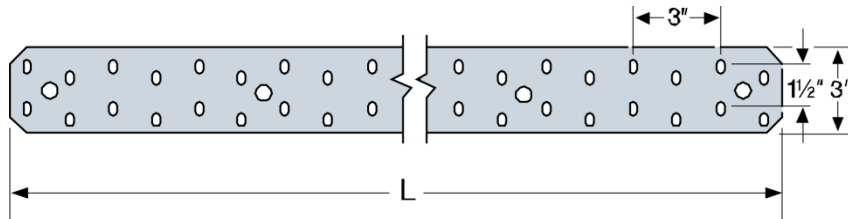

FIGURE 9—MSTC SERIES TIE STRAP

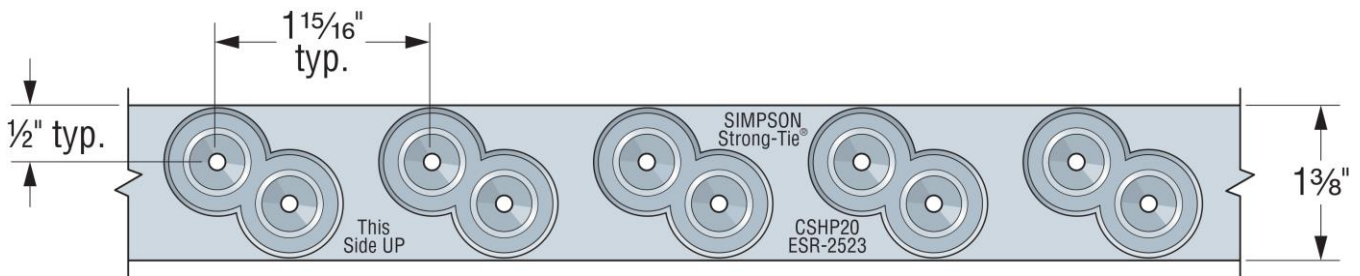

FIGURE 10—CSHP SERIES TIE STRAP  
(SEE TABLE 4 NEXT PAGE)

TABLE 4—ALLOWABLE TENSION LOADS FOR THE CS AND CMST SERIES COIL STRAPS AND THE CMSTC16 COIL TIE STRAP

MODEL SERIES	MODEL NO.	TIE STRAP PROPERTIES				NAILS <sup>1</sup> (Quantity–Size)	ALLOWABLE TENSION LOADS <sup>2,3</sup> (lbs)	
		Thickness (Gage No.)	Length	Min. $F_y$ (ksi)	Min. $F_u$ (ksi)		$C_D = 1.6$	Based on Steel Strength <sup>5</sup>
CS	CS14	14	Cut to length	50	65	26–10d×2 <sup>1</sup> / <sub>2</sub> common	2,590	2,490
						30–8d common	2,505	2,490
	CS16	16	Cut to length	40	55	20–10d×2 <sup>1</sup> / <sub>2</sub> common	1,890	1,705
						22–8d common	1,725	1,705
	CS18	18	Cut to length	40	55	16–10d×2 <sup>1</sup> / <sub>2</sub> common	1,490	1,370
						18–8d common	1,385	1,370
	CS20	20	Cut to length	40	55	12–10d×2 <sup>1</sup> / <sub>2</sub> common	1,100	1,030
						14–8d common	1,065	1,030
	CS22	22	Cut to length	40	55	10–10d×2 <sup>1</sup> / <sub>2</sub> common	915	845
						12–8d common	905	845
CSHP	CSHP18	18	Cut to length	40	55	14–10d×2 <sup>1</sup> / <sub>2</sub> common	1680	1540
						16–8d common	1650	1540
	CSHP20	20	Cut to length	40	55	12–10d×2 <sup>1</sup> / <sub>2</sub> common	1380	1160
						12–8d common	1180	1160
CMST	CMST12	12	Cut to length	50	65	74–16d×2 <sup>1</sup> / <sub>2</sub> common	9,430	9,215
						86–10d×2 <sup>1</sup> / <sub>2</sub> common	9,430	9,215
	CMST14	14	Cut to length	50	65	56–16d×2 <sup>1</sup> / <sub>2</sub> common	6,550	6,475
						66–10d×2 <sup>1</sup> / <sub>2</sub> common	6,565	6,475
CMSTC	CMSTC16	16	Cut to length	50	65	50–16d sinker	4,805	4,690

For SI: 1 inch = 25.4 mm, 1 lbf = 4.45 N.

<sup>1</sup>Total fasteners are the minimum number of nails required to achieve the tabulated allowable loads. One half of the total must be installed in each wood member forming the connection. Fasteners must comply with Section 3.5.3 of this report.

<sup>2</sup>Allowable tension loads are based on the steel straps connected to wood members having an assigned or equivalent minimum specific gravity of 0.50.

<sup>3</sup>Allowable tension loads must be the lesser of the tie strap steel strength or the connection strength.

<sup>4</sup>Allowable tension loads based on connection strength are derived by multiplying the number of nails by the minimum value from the yield mode equations in Section 12.3.1 from the 2018 and 2015 NDS and Section 11.3.1 from the 2012 NDS, where the side member (i.e., the steel tie strap) dowel bearing strength,  $F_{es}$ , is equal to  $2.2F_u/C_D$ , where  $C_D$  equals 1.6 as shown in the table, and where the minimum specified tensile strength,  $F_u$  of the steel strap is as shown in the table. Allowable tension loads governed by connection strength have been multiplied by the load duration factor,  $C_D$ , noted in the table.

<sup>5</sup>The tabulated allowable tension loads based on steel strength do not include a one-third stress increase, and are the least of yielding at the gross section of the strap, the fracture in the net section away from the connection, and fracture at the connection in accordance with Section C2 of AISI S100-16/S1-18 and S2-20 (2021 IBC), Section C2 of AISI S100-16 (2018 IBC), AISI S100-12 (2015 IBC) or Section C2 of AISI S100-07/S2-10 (2012 IBC).

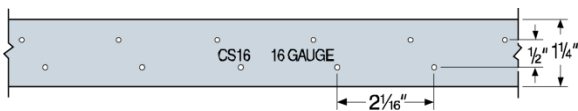

FIGURE 11—CS SERIES TIE STRAP

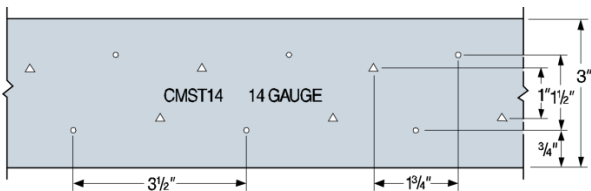

FIGURE 12—CMST14 TIE STRAP

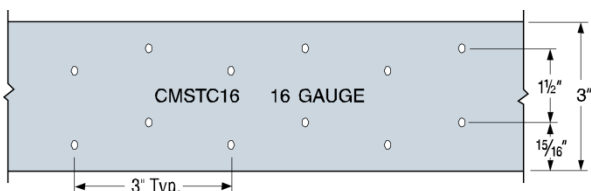

FIGURE 13—CMSTC16 TIE STRAP

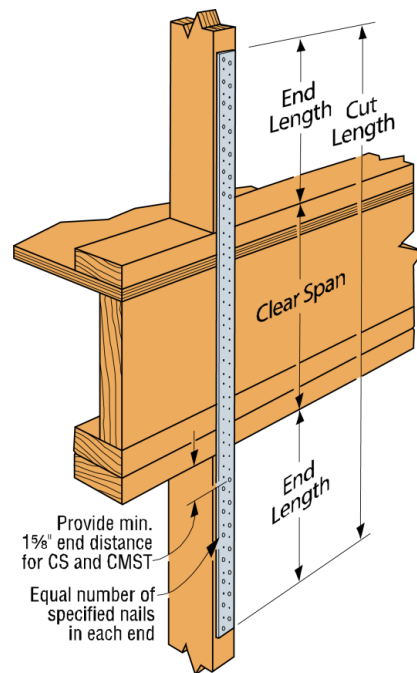

FIGURE 14—TYPICAL INSTALLATION OF CS, CMST, AND CMSTC16 TIE STRAP

TABLE 5—ALLOWABLE TENSION AND COMPRESSION LOADS FOR CTS SERIES STRAP

MODLE NO.	STRAP QTY.	INSTALLATION	FASTENERS <sup>2</sup> (Quantity-Size)	ALLOWABLE LOADS <sup>3</sup> (lbs)	
				Compression (C <sub>D</sub> = 1.60) <sup>4,5</sup>	Tension (C <sub>D</sub> = 1.60)
CTS218 <sup>1</sup>	1	One Side	24 – 10d x 1 1/2	1,125	2,270 <sup>6</sup>
	2	One Side		2,250	4,535 <sup>6</sup>
	2	Two Side		2,515	4,535 <sup>6</sup>
	3	Two Side		3,310	6,805 <sup>6</sup>
	4	Two Side		5,035	9,070 <sup>6</sup>
	1	One Side	24 – SD#9 x 1 1/2	1,175	2,510 <sup>7</sup>
	2	One Side		2,350	5,020 <sup>7</sup>
	2	Two Side		2,735	5,020 <sup>7</sup>
	3	Two Side		4,130	7,530 <sup>7</sup>
	4	Two Side		5,470	10,040 <sup>7</sup>

For SI: 1 inch = 25.4 mm, 1lbf = 4.45 N, 1 psi = 6.89 MPa.

<sup>1</sup>Strap properties: minimum F<sub>y</sub> = 33, 000 pound per square inch (psi) and minimum F<sub>u</sub> = 45, 000 psi. 14 gage steel.

<sup>2</sup>Fastener quantities are for a single strap.

<sup>3</sup>Allowable loads are based on steel straps connected to wood members having an assigned or equivalent minimum specific gravity of 0.50.

<sup>4</sup>The maximum gap between wood framing members is 4 1/2 inches (114 mm).

<sup>5</sup>The tabulated allowable compression capacity is controlled by steel buckling and is a tested load.

<sup>6</sup>The tabulated allowable tension loads are governed by the connection strength and have been multiplied by the load duration factor, C<sub>D</sub>, of 1.60, as shown in the table. Connection strength is derived by multiplying half of the required number of nails by the minimum values in the yield mode equations in Section 12.3.1 of the 2018 and 2015 NDS and Section 11.3.1 of the 2012 NDS, where the side member (i.e. steel strap) dowel bearing strength, F<sub>es</sub>, is equal to 2.2F<sub>u</sub>/C<sub>D</sub>, where F<sub>u</sub> of steel strap equals to 45,000 psi.

<sup>7</sup>The tabulated allowable tension loads are governed by the steel strength, and does not include the 1/3 steel stress increase or the load duration factor, C<sub>D</sub>. The steel strength is the least of the yielding at the gross section of the strap, the fracture at the net section away from the connection, and fracture at the connection in accordance with Section C2 of AISI S100-16/S1-18 and S2-20 (2021 IBC), Section C2 of AISI S100-16 (2018 IBC), AISI S100-12 (2015 IBC) or Section C2 of AISI S100-07/S2-10 (2012 IBC)..

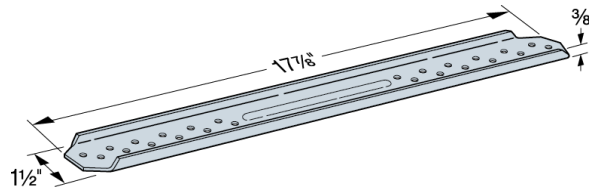

FIGURE 15—CTS218 COMPRESSION STRAP

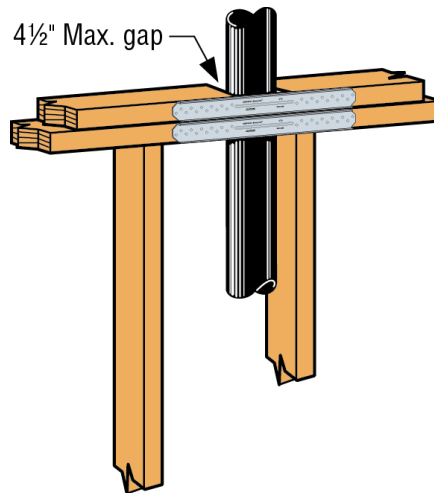

FIGURE 16—TYPICAL INSTALLATION OF CTS218 COMPRESSION/TENSION STRAP (TWO-STRAP, ONE-SIDED INSTALLATION SHOWN)

TABLE 6—ALLOWABLE TENSION LOADS FOR THE MSTCB3 SERIES PRE-BENT TIE STRAPS<sup>1,2,3,4,5</sup>

MODEL NO.	TIE STRAP PROPERTIES				MIN. WOOD BEAM DIMENSIONS		COMMON NAILS (Total Quantity-Size)			ALLOWABLE TENSION LOADS (lbs)
	Thickness (Gage No.)	Length (inches)	Min. $F_y$ (ksi)	Mini. $F_u$ (ksi)	Width (min)	Depth (min)	Beam		Studs/Post	
							Face	Bottom		
MSTC48B3	14	44 <sup>7</sup> / <sub>8</sub>	50	65	3	9 <sup>1</sup> / <sub>4</sub>	12-10d	4-10d	38-10d	C <sub>D</sub> = 1.6 3,975
MSTC66B3Z	14	62 <sup>7</sup> / <sub>8</sub>	50	65	3 <sup>1</sup> / <sub>2</sub>	11 <sup>1</sup> / <sub>4</sub>	14-10d			4,490

For SI: 1 inch = 25.4 mm, 1lbf = 4.45 N, 1 psi = 6.89 MPa.

<sup>1</sup> Nails in studs/post must be installed symmetrically. Nails may be installed over the entire length of the strap over the studs/post.

<sup>2</sup> Allowable tension loads are based on steel straps connected to wood members having an assigned or equivalent minimum specific gravity of 0.50. The beam must also have a reference compression design value perpendicular to grain,  $F_{c\perp}$ , of 625 psi (4,310 MPa) or greater.

<sup>3</sup> The tabulated allowable tension loads are based on the lowest value of the tested tension load at 0.125 inch deflection from static tests on wood members, the connection strength in accordance with Footnote 4, and the steel strength in accordance with Footnote 5. Further increase of the tabulated allowable tension loads is not permitted.

<sup>4</sup> Allowable tension loads based on connection strength are derived by multiplying the number of nails by the minimum value from the yield mode equations in Section 12.3.1 of the 2018 and 2015 NDS and Section 11.3.1 of the 2012 NDS, where the side member (i.e., the steel tie strap) dowel bearing strength,  $F_{es}$ , is equal to  $2.2F_u/C_D$ , where  $C_D$  equals 1.6 as shown in the table, and where the minimum specified tensile strength,  $F_u$ , of the steel strap is as shown in the table. Allowable tension loads governed by connection strength have been multiplied by the load duration factor,  $C_D$ , noted in the table.

<sup>5</sup> The tabulated allowable tension loads based on steel strength do not include a one-third stress increase, and are the least of yielding at the gross section of the strap, the fracture in the net section away from the connection, and fracture at the connection in accordance with Section C2 of AISI S100-16/S1-18 and S2-20 (2021 IBC), Section C2 of AISI S100-16 (2018 IBC), AISI S100-12 (2015 IBC) or Section C2 of AISI S100-07/S2-10 (2012 IBC).

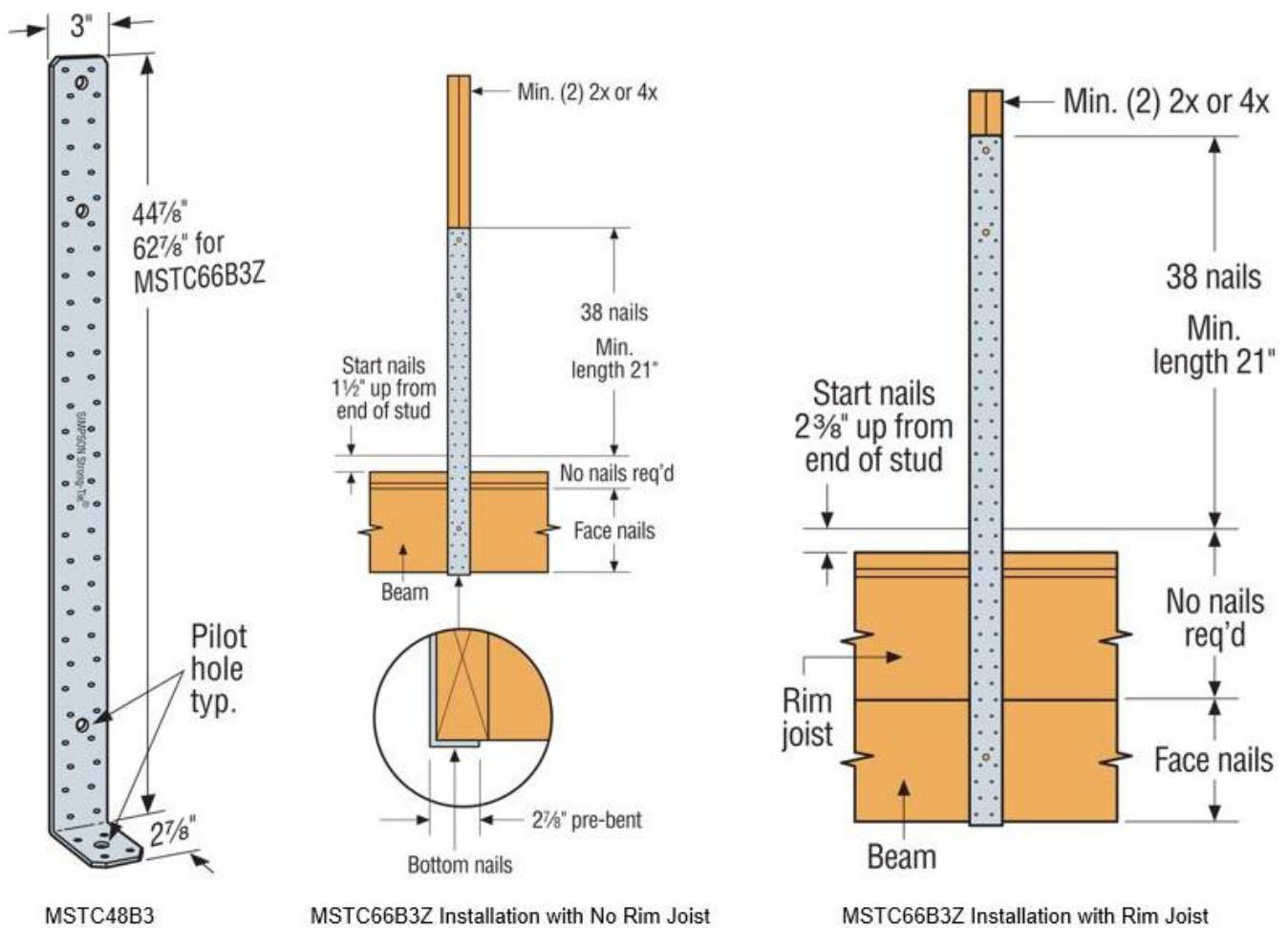

FIGURE 17—MSTCB3 SERIES PRE-BENT TIE STRAPS

TABLE 7 - ALLOWABLE TENSION LOADS FOR THE MDCST MEDIUM DUTY DIAPHRAGM CHORD STRAP TIE<sup>1,2,3</sup>

MODEL NO.	Ga.	Dimensions (in.)		Min. F <sub>v</sub> (ksi)	Min. F <sub>u</sub> (ksi)	Fasteners (Total) (in.)	ALLOWABLE TENSION LOADS (lbs)
		W	L				C <sub>D</sub> = 1.6
MDCST48	14	5 <sup>3</sup> / <sub>4</sub>	47 <sup>1</sup> / <sub>2</sub>	50	65	(36) 1/4" x 3" SDS	11,905
MDCST48 (Doubled/Overlapped)	14	5 <sup>3</sup> / <sub>4</sub>	47 <sup>1</sup> / <sub>2</sub>	50	65	(72) 1/4" x 3" SDS	23,810
MDSS96	14	5 <sup>3</sup> / <sub>4</sub>	95 <sup>1</sup> / <sub>2</sub>	50	65	(40) 1/4" x 3" SDS	12,230
LDSS48	18	3 3/4	47 1/2	33	45	(36) 10d x 2 1/2" Common	3,660

For SI: 1 inch = 25.4 mm, 1lbf = 4.45 N, 1 psi = 6.89 MPa.

<sup>1</sup> Total fasteners are the minimum number of fasteners required to achieve the tabulated allowable loads. One half of the total must be installed in each wood member forming the connection. For a single strap, fill only round holes. For a double/overlapped strap, fill round and triangle holes. Fasteners must comply with Section 3.5.3 of this report.

<sup>2</sup> Allowable tension loads are based on the steel straps connected to wood members having an assigned or equivalent minimum specific gravity of 0.50.

<sup>3</sup> Tabulated allowable tension loads are the lesser of the wood connection strength and tie strap steel strength. The wood connection strength is derived by multiplying the number of SDS fasteners by the published allowable load in ESR-2236, where C<sub>D</sub> equals 1.6, as shown in the table. The tie straps steel strength is the least of yielding at the gross section of the strap, the fracture in the net section away from the connection, and fracture at the connection, in accordance with Section C2 of AISI S100-16 (2021 & 2018 IBC), AISI S100-12 (2015 IBC) or Section C2 of AISI S100-07/S2-10 (2012 IBC). The tabulated allowable tension loads based on steel strength do not include a one-third stress increase.

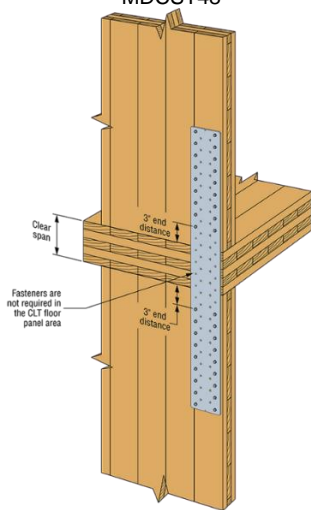
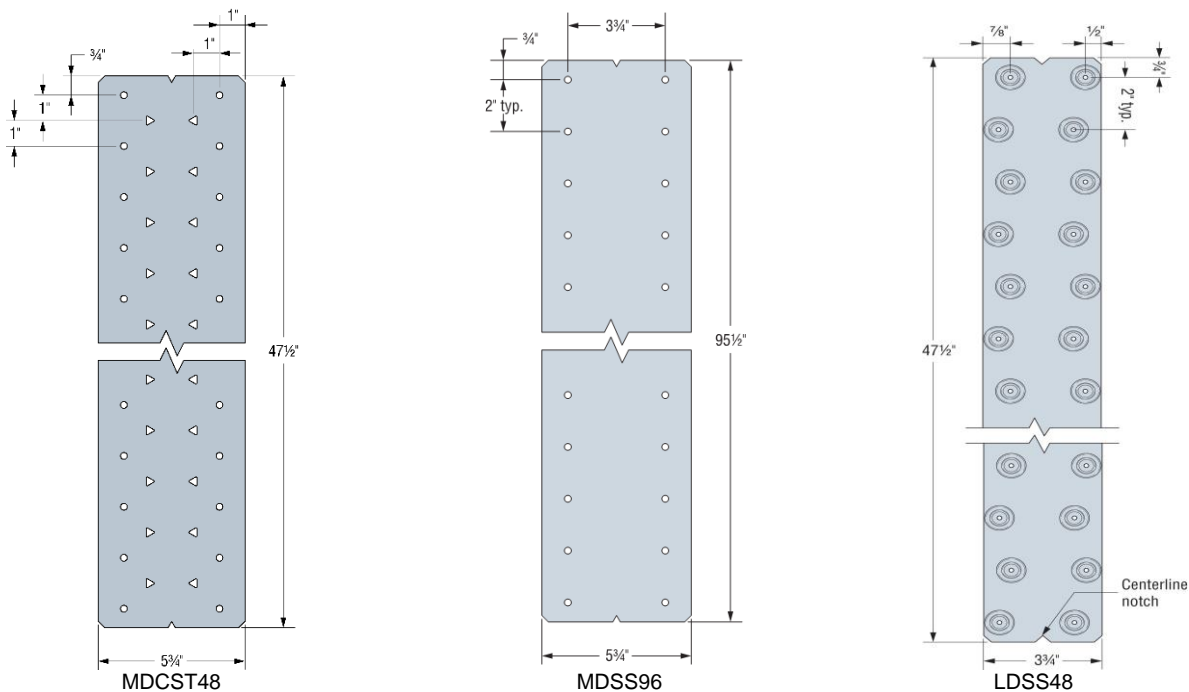

MDCST48 FLOOR-TO-FLOOR  
(MDSS96 SIMILAR)

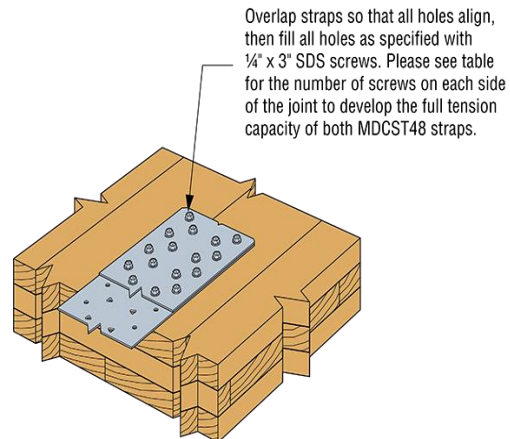

FIGURE 18—MDCST AND MDSS MEDIUM DUTY AND LDSS LIGHT DUTY DIAPHRAGM CHORD TIE STRAPS

**DIVISION: 06 00 00—WOOD, PLASTICS AND COMPOSITES**  
**Section: 06 05 23—Wood, Plastic, and Composite Fastenings**

**REPORT HOLDER:**

**SIMPSON STRONG-TIE COMPANY INC.**

**EVALUATION SUBJECT:**

**SIMPSON STRONG-TIE STRAPS**

**1.0 REPORT PURPOSE AND SCOPE****Purpose:**

The purpose of this evaluation report supplement is to indicate that Simpson Strong-Tie straps, described in ICC-ES evaluation report [ESR-2105](#), have also been evaluated for compliance with the codes noted below as adopted by the Los Angeles Department of Building and Safety (LADBS).

**Applicable code editions:**

- 2023 *City of Los Angeles Building Code* (LABC)
- 2023 *City of Los Angeles Residential Code* (LARC)

**2.0 CONCLUSIONS**

The Simpson Strong-Tie straps, described in Sections 2.0 through 7.0 of the evaluation report [ESR-2105](#), comply with the LABC Chapter 23, and the LARC, and are subjected to the conditions of use described in this supplement.

**3.0 CONDITIONS OF USE**

The Simpson Strong-Tie straps, described in this evaluation report supplement must comply with all of the following conditions:

- All applicable sections in the evaluation report [ESR-2105](#).
- The design, installation, conditions of use and labeling are in accordance with the 2021 *International Building Code*® (2021 IBC) provisions noted in the evaluation report [ESR-2105](#).
- The design, installation and inspection are in accordance with additional requirements of LABC Chapters 16, 17 and 23 as applicable.
- In accordance with LABC Section 2305.5, allowable seismic load values of Simpson Strong-Tie straps and ties used as hold-down connectors must be 75 percent of those in the evaluation report [ESR-2105](#).
- Under the LARC, an engineered design in accordance with LARC Section R301.1.3 must be submitted.
- The seismic design provisions for hillside buildings referenced in LABC Section 2301.1 have not been considered and are outside of the scope of this supplement.

This supplement expires concurrently with the evaluation report ESR-2105, reissued January 2024.

**DIVISION: 06 00 00—WOOD, PLASTICS AND COMPOSITES**  
**Section: 06 05 23—Wood, Plastic, and Composite Fastenings**

**REPORT HOLDER:**

**SIMPSON STRONG-TIE COMPANY INC.**

**EVALUATION SUBJECT:**

**SIMPSON STRONG-TIE STRAPS**

**1.0 REPORT PURPOSE AND SCOPE****Purpose:**

The purpose of this evaluation report supplement is to indicate that the Simpson Strong-Tie straps, described in ICC-ES evaluation report ESR-2105, have also been evaluated for compliance with the codes noted below.

**Applicable code editions:**

- 2023 Florida Building Code—Building
- 2023 Florida Building Code—Residential

**2.0 CONCLUSIONS**

The Simpson Strong-Tie straps, described in Sections 2.0 through 7.0 of ICC-ES evaluation report ESR-2105, comply with the *Florida Building Code—Building* and the *Florida Building Code—Residential*. The design requirements must be determined in accordance with the *Florida Building Code—Building* or the *Florida Building Code—Residential*, as applicable. The installation requirements noted in ICC-ES evaluation report ESR-2105 for the 2021 *International Building Code*® meet the requirements of the *Florida Building Code—Building* or the *Florida Building Code—Residential*, as applicable. Use of the Simpson Strong-Tie straps has also been found to be in compliance with the High-Velocity Hurricane Zone provisions of the *Florida Building Code—Building* and the *Florida Building Code—Residential* with the following condition:

- a. For connections subject to uplift, the connection must be designed for no less than 700 pounds (3114 N).

For products falling under Florida Rule 61G20-3, verification that the report holder's quality assurance program is audited by a quality assurance entity approved by the Florida Building Commission for the type of inspections being conducted is the responsibility of an approved validation entity (or the code official when the report holder does not possess an approval by the Commission).

This supplement expires concurrently with the evaluation report ESR-2105, reissued January 2024.