



Most Widely Accepted and Trusted

ICC-ES Report

ESR-3969

ICC-ES | (800) 423-6587 | (562) 699-0543 | www.icc-es.org

Issued 01/2017
This report is subject to renewal 01/2018.

**DIVISION: 31 00 00—EARTHWORK
SECTION: 31 63 00—BORED PILES**

REPORT HOLDER:

PIERTECH SYSTEMS, LLC

**17813 EDISON AVENUE, SUITE 100
CHESTERFIELD, MISSOURI 63005**

EVALUATION SUBJECT:

PIERTECH HELICAL FOUNDATION SYSTEMS



Look for the trusted marks of Conformity!

“2014 Recipient of Prestigious Western States Seismic Policy Council (WSSPC) Award in Excellence”



A Subsidiary of  **INTERNATIONAL CODE COUNCIL™**

ICC-ES Evaluation Reports are not to be construed as representing aesthetics or any other attributes not specifically addressed, nor are they to be construed as an endorsement of the subject of the report or a recommendation for its use. There is no warranty by ICC Evaluation Service, LLC, express or implied, as to any finding or other matter in this report, or as to any product covered by the report.



ICC-ES Evaluation Report

ESR-3969

Issued January 2017

This report is subject to renewal January 2018.

www.icc-es.org | (800) 423-6587 | (562) 699-0543

A Subsidiary of the International Code Council®

DIVISION: 31 00 00—EARTHWORK
Section: 31 63 00—Bored Piles

REPORT HOLDER:

PIERTECH SYSTEMS, LLC
17813 EDISON AVENUE, SUITE 100
CHESTERFIELD, MISSOURI 63005
(636) 536-5007
www.piertech.com

EVALUATION SUBJECT

PIERTECH HELICAL FOUNDATION SYSTEMS

1.0 EVALUATION SCOPE

Compliance with the following codes:

2015, 2012, and 2009 *International Building Code*® (IBC)

Properties evaluated

Structural and geotechnical

2.0 USES

The PierTech helical foundation systems are used either to underpin foundations of existing structures or to form deep foundations for new structures; and are designed to transfer compression load from the supported structure to suitable soil bearing strata. Underpinning of existing foundations is generally achieved by attaching the helical piles to the side-load brackets, which support only compression loads. Deep foundations for new construction are generally obtained by attaching the helical piles to direct-load brackets that are embedded in concrete pile caps, footings, or grade beams, which support only compression load.

3.0 DESCRIPTION

3.1 General:

The PierTech helical foundation systems consist of a lead shaft section with one or more helical-shaped steel bearing plates (or helices), extension shaft section(s), couplings that connect multiple shaft sections, and a bracket that allows for attachment to the supported structures. The shafts with helix bearing plates are screwed into the ground by application of torsion and the shaft is extended until a desired depth or a suitable soil or bedrock bearing stratum is reached. The bracket is then installed to connect the pile to the concrete foundation of the supported structure. See Figure 5 of this report.

3.2 System Components:

3.2.1 Helical Piles: The PierTech helical pile lead shaft sections consist of one or more (up to four) helical-shaped circular steel plates factory-welded to the lead steel shaft. The extension shaft sections have shafts similar to the lead shaft sections, except without the helical plates. The depth of the helical piles in soil is typically extended by adding one or more steel shaft extensions that are mechanically connected together by couplers to form one continuous steel pile.

The shaft lead sections and extension sections consist of a 2⁷/₈-inch-outside-diameter (73 mm) round hollow steel tubing having a nominal wall thickness of 0.217-inch (5.5 mm) minimum wall thickness.

Each helical steel bearing plate (helix) is 3³/₈-inch (9.5 mm) thick and has spiral edge geometry with an outer diameter of 8, 10, 12 or 14-inches (203, 254, 305 or 356 mm). The helix plates are pressed to form a 3-inch (76.2 mm) pitch, which is the distance between the leading and trailing edges. The lead helix is located near the tip (bottom end) of the shaft lead section. For multiple helix installation, the helical bearing plates are spaced three times the diameter of the lowest plate apart starting at the toe of the lead section. Typically, the smallest diameter helical bearing plate is placed near the tip (bottom) of the lead section and the largest diameter helical bearing plate is placed nearest the top (trailing end) of the lead section or on an extension section.

The helical pile lead shaft sections and extension sections are connected together by bolting the male and female couplers. The male coupler consists of a 2.875-inch-outside-diameter (59 mm) round hollow steel casting, as shown in Figure 3. The female coupler consists of a 3.42-inch-outside-diameter (87 mm) round hollow steel casting with a 3.31-inch-inside-diameter (84 mm), as shown in Figure 4. Each extension section consists of a female coupler and a male coupler which are welded, in the factory, to the opposing extension ends. Each lead shaft section consists of a male coupler that is welded, in the factory, to the top end of the lead shaft. Connection of extension sections to the lead shaft or other extension sections is made by through-bolted connections with two 3³/₄-inch-diameter (19 mm) steel bolts through the extension section's female coupler and the connected lead section or extension section's male coupler. Figures 3 and 4 illustrate the female coupler and the male coupler.

Lead sections and extension sections may be either bare steel or hot-dipped galvanized in accordance with ASTM A123.

3.2.2 Brackets: Brackets are constructed from steel plate and steel pipe components, which are factory-welded together. The different brackets are described in Sections 3.2.2.1 and 3.2.2.2. All brackets may be either bare steel or hot-dipped galvanized in accordance with ASTM A123.

3.2.2.1 Type A Side Load Bracket: This bracket is used to support existing concrete foundations by transferring axial compressive loads from the existing foundations to the helical pile. The bracket shelf is constructed of a $\frac{1}{2}$ -inch-thick (12.7 mm) steel plate measuring 13.75 inches (349 mm) wide by 12 inches (305 mm) long. The bracket shelf is factory-welded to $\frac{1}{2}$ -inch-thick (12.7mm) steel plate stiffeners to form the bracket main body. The bracket main body is factory-welded to a $3\frac{1}{2}$ -inch-outside-diameter (89 mm) round hollow steel tubing having a nominal wall thickness of 0.25-inch (6.4 mm) minimum wall thickness and a length of 18 inches (457 mm). See Figures 2 and 5 of this report. A lifting T-bracket (Tru-Lift Slider) consists of steel plates factory-welded to a $2\frac{1}{4}$ -inch-outside-diameter (57 mm) round hollow steel tubing having a nominal wall thickness of 0.344-inch (8.7 mm) and a length of 18 inches (457 mm). The lifting T-bracket (Tru-Lift Slider) is connected to the bracket main body with two $\frac{7}{8}$ -inch-diameter steel threaded rods, four matching steel nuts, and matching steel washers. See Figures 2 and 5 of this report. The repair brackets may be either bare steel or hot-dipped galvanized in accordance with ASTM A123.

3.2.2.2 Type B Direct Load Bracket: This bracket is used with the helical pile system in new construction where the steel bearing plate of the bracket is cast into new concrete grade beams, footings, or pile caps. The brackets can only transfer compression load between the pile and the concrete foundation. Refer to footnotes in Table 1 for requirements of concrete cover and end/edge distance. The bracket consists of a 6-by-6-by- $\frac{1}{2}$ -inch-thick (152 by 152 by 13 mm) bearing plate factory-welded to a round 3.43-inch-outside-diameter (89mm) round hollow steel casting with a 3-inch-inside-diameter (76 mm) and a length of 4.44 inches (113 mm). The bracket is attached to the shaft in the field with two $\frac{3}{4}$ -inch (19 mm) standard hex bolts with matching $\frac{3}{4}$ -inch (19 mm) standard hex nuts. See Figure 1 of this report. The brackets maybe either bare steel or hot-dipped galvanized in accordance with ASTM A123.

3.3 Material Specifications:

3.3.1 Helix Plates: The $\frac{3}{8}$ -inch thick helix plates have an outer diameter of 8, 10, 12, or 14 inches (203, 254, 305 or 356 mm) which are made from carbon steel plates conforming to ASTM A572 Grade 50, and having a minimum yield strength of 50,000 psi (345 MPa) and a minimum tensile strength of 65,000 psi (488 MPa). The helix plates are factory-welded to the lead shafts, and are either bare steel or hot-dipped galvanized in accordance with ASTM A123.

3.3.2 Helical Pile Lead Shafts and Extensions: The lead shafts and extensions are round hallowed steel tubes that conform to ASTM A500 Grade B/C, and having a minimum yield strength of 60,000 psi (413 MPa) and a minimum tensile strength of 63,000 psi (434 MPa). The lead shafts and extensions may be either bare steel or hot-dipped galvanized in accordance with ASTM A123.

3.3.3 Male and Female Couplers: The male and female couplers are round hallowed steel casting conforming to ASTM A915 Grade SC8630, having a

minimum yield strength of 116,000 psi (800 MPa) and a minimum tensile strength of 123,250 psi (850 MPa). The couplers are factory-welded to shaft leads and extensions. The couplers may be either bare steel or hot-dipped galvanized in accordance with ASTM A123.

3.3.4 Type A Side Load Brackets: The plates used to fabricate Type A bracket's main body and T-brackets conform to ASTM A572 Grade 50, having a minimum yield strength of 50,000 psi (344 MPa) and a minimum tensile strength of 65,000 psi (448 MPa). The $3\frac{1}{2}$ -inch-outside-diameter round steel tubing that is factory-welded to the bracket main body and the $2\frac{1}{4}$ -inch-outside-diameter (57 mm) round steel tubing which is a part of the lifting T-bracket are made from steel conforming to ASTM A500 Gr. C, having a minimum yield strength of 46,000 psi (317 MPa) and a minimum tensile strength of 62,000 psi (427 MPa). The fully threaded rods conforming to ASTM A449, having a minimum tensile strength of 120,000 psi (827 MPa). ASTM A563 Grade DH nuts and ASTM F436 washers are used to fasten the treaded rods to the bracket. Type A bracket may be either bare steel or hot-dipped galvanized in accordance with ASTM A123.

3.3.5 Type B Direct Load Brackets: The $\frac{1}{2}$ -inch steel bearing plate conforms to ASTM A572 Grade 50, having a minimum yield strength of 50,000 psi (344 MPa) and a minimum tensile strength of 65,000 psi (448 MPa). The round hallowed steel casting conforms to ASTM A915 Grade SC8630, and having a minimum yield strength of 116,000 psi (800 MPa) and a minimum tensile strength of 123,250 psi (850 MPa). When required, the bolts connecting the Type B bracket to the shaft/extension must comply with Section 3.3.6 of this report. Type B brackets are made from either bare steel or hot-dipped galvanized in accordance with ASTM A123.

3.3.6 All Other Fastening Assemblies (Including Brackets): The bolts, used to connect the lead and extension sections, or connect shaft to Type B bracket, conform to ASTM A325, having a tensile strength of 120,000 psi (827 MPa). The matching hex nuts conform to ASTM A563 Grade DH. The bolts and nuts can either be bare steel or hot-dipped galvanized in accordance with ASTM A153.

4.0 DESIGN AND INSTALLATION

4.1 Design:

4.1.1 General: Engineering calculations (analysis and design) and drawings, prepared by a registered design professional, must be submitted to and be subjected to the approval of the code official for each project, and must be based on accepted engineering principles, as described in IBC Section 1604.4, and must conform to IBC Section 1810. The design method for the steel components is Allowable Strength Design (ASD), described in IBC Section 1602 and AISC 360 Section B3.4. The engineering analysis must address helical foundation system performance related to structural and geotechnical requirements.

The structural analysis must consider all applicable internal forces (shears, bending moments and torsional moments, if applicable) due to applied loads, structural eccentricity and maximum span(s) between helical foundations. The result of this analysis and the structural capacities must be used to select a helical foundation system.

The PierTech direct load brackets (Type B brackets) exert a force on the footing or grade beam in which they are embedded. The force is equal in magnitude and

opposite in direction to the force in the pile. A small lateral force is developed at the bracket embedment if the pile shaft is not perfectly plumb but within the permitted inclination from vertical of $\pm 1^\circ$. The lateral shear is equal to $\sin(1^\circ)$ or $0.0175 \times$ the axial force exerted on the pile by the foundation.

The minimum embedment depth of piles for various loading conditions must be included based on the most stringent requirements of the following: engineering analysis, tested conditions described in this report, the site specific geotechnical investigation report, and site specific load tests, if applicable.

The allowable strengths (allowable capacities) of the steel components of the PierTech helical foundation systems are described in Table 1 (for brackets, P1); Table 2(A) (for shafts, P2); and Table 3 (for helical bearing plates, P3). The soil capacities, or capacities related to pile-soil interactions, (P4), are described in Section 4.1.5 and Table 4.

The overall capacity of the PierTech helical foundation systems depends upon the analysis of interaction of shafts, helical plates and soils, and must be based on the least of the following conditions (P1, P2, P3 and P4), in accordance with IBC Section 1810.3.3.1.9:

- P4: Allowable load predicted by the individual helix bearing method (or Method 1) described in Section 4.1.5 of this report.
- P4: Allowable load predicted by the torque correlation method described in Section 4.1.5 of this report.
- P4: Allowable load predicted by dividing the ultimate capacity determined from load tests (Method 2 described in Section 4.1.5) by a safety factor of at least 2.0. This allowable load will be determined by a registered design professional for each site-specific condition.
- P3: Sum of the allowable axial capacity of helical bearing plates affixed to the pile shaft. See Section 4.1.4 of this report.
- P2: Allowable axial compression load capacity of the shaft as described in Section 4.1.3 of this report.
- P1: Allowable axial load capacity of the bracket. See Section 4.1.2 of this report.

A written report of the geotechnical investigation must be submitted to the code official as part of the required submittal documents, prescribed in IBC Section 107, at the time of the permit application. The geotechnical report must include, but not be limited to, all of the following information:

- A plot showing the location of the soil investigation.
- A complete record of the soil boring and penetration test logs and soil samples.
- A record of soil profile.
- Information on ground-water table, frost depth and corrosion related parameters, as described in Section 5.5 of this report.
- Soil properties, including those affecting the design such as support conditions of the piles.
- Soil design parameters, such as shear strength parameters as required by Section 4.1.5; soil deformation parameters; and relative pile support conditions as defined in IBC Section 1810.2.1.

- Confirmation of the suitability of PierTech helical foundation systems for the specific project.
- Recommendations for design criteria, including but not be limited to: mitigations of effects of differential settlement and varying soil strength; and effects of adjacent loads.
- Recommended center-to-center spacing of helical pile foundations, if different from Section 5.14 of this report; and reduction of allowable loads due to the group action, if necessary.
- Field inspection and reporting procedures (to include procedures for verification of the installed bearing capacity when required).
- Load test requirements.
- Any questionable soil characteristics and special design provisions, as necessary.
- Expected total and differential settlement.
- The axial compression, axial tension and lateral load soil capacities for allowable capacities that cannot be determined from this evaluation report.
- Minimum helical pile depth, if any, based on local geologic hazards such as frost, expansive soils, or other condition.

4.1.2 Bracket Capacity (P1): Table 1 describes the allowable bracket capacity for Type A (Side Load) Brackets, and Type B (Direct Load) Brackets. The connections of the building structure to the helical pile brackets must be designed and included in the construction documents. Only localized limit states of steel and supporting concrete including 2-way punching shear and concrete bearing have been evaluated in this evaluation report. The concrete foundation must be designed and justified to the satisfaction of the code official with due consideration to the eccentricity of applied loads, including reactions provided by the brackets, acting on the concrete foundation. Refer to item 5.3 of this report for bracing requirement.

4.1.3 Shaft Capacity (P2): Table 2(A) describes the allowable axial compression loads of the shaft. Table 2(B) describes the mechanical properties of the shaft which are based on a 50-year corrosion effect in accordance with Section 3.9 of AC308. The top of shafts must be braced as prescribed in IBC Section 1810.2.2, and the supported foundation structures such as concrete footings are assumed to be adequately braced such that the supported foundation structures provide lateral stability for the pile systems. In accordance with IBC Section 1810.2.1, any soil other than fluid soil must be deemed to afford sufficient lateral support to prevent buckling of the systems that are braced, and the unbraced length is defined as the length of piles that is standing in air, water or in fluid soils plus additional 5 feet (1524 mm) when embedded into firm soil or additional 10 feet (3048 mm) when embedded into soft soil. Firm soils shall be defined as any soil with a Standard Penetration Test blow count of five or greater. Soft soil shall be defined as any soil with a Standard Penetration Test blow count greater than zero and less than five. Fluid soils shall be defined as any soil with a Standard Penetration Test blow count of zero [weight of hammer (WOH) or weight of rods (WOR)]. Standard Penetration Test blow count shall be determined in accordance with ASTM D1586. The shaft capacity of the helical foundation systems with an unbraced length more than zero must be determined by a registered design

professional using parameters in Table 2(B) with due consideration of lateral support provided by the surrounding soil and/or structure.

The elastic shortening of the pile shaft will be controlled by the strength and section properties of the shaft sections and coupler(s). For loads up to and include the allowable load limits found in this report, the elastic shortening of shaft can be estimated as:
 $\Delta_{\text{shaft}} = P L / (A E)$

where:

Δ_{shaft} = Length change of shaft resulting from elastic shortening, in (mm).

P = applied axial load, lbf (N).

L = effective length of the shaft, in. (mm).

A = cross-sectional area of the shaft, see Table 2(B), in.² (mm²).

E = Young's modulus of the shaft, see Table 2(B), ksi (MPa).

For each coupler, an elastic shortening of 0.002 inch (0.051 mm) is estimated at allowable shaft load, and a slip of 0.260 inch (6.60 mm) is estimated at allowable shaft load. For shaft, an elastic shortening of 0.002 inch per foot of shaft (0.167 mm/m) is estimated at allowable shaft load.

4.1.4 Helix Capacity (P3): Table 3 describes the allowable axial compression loads for helical bearing plates. For helical piles with more than one helix, the allowable helix capacity, P3, for the helical foundation systems and devices, may be taken as the sum of the least allowable capacity of each individual helix.

4.1.5 Soil Capacity (P4): Table 4 describes the geotechnical related properties of the piles. The allowable compressive soil capacity (P4) must be determined by a registered design professional in accordance with a site-specific geotechnical report, as described in Section 4.1.1 combined with the individual helix bearing method (Method 1) or from field loading tests conducted under the supervision of a registered design professional (Method 2). For either Method 1 or Method 2, the predicted axial load capacities must be confirmed during the site-specific production installation, such that the axial load capacities predicted by the torque correlation method must be equal to or greater than what is predicted by Method 1 or 2, described above.

The individual bearing method is determined as the sum of the individual areas of the helical bearing plates times the ultimate bearing capacity of the soil or rock comprising the bearing stratum for helix plates.

The design allowable axial capacity must be determined by dividing the total ultimate axial load capacity predicted by either Method 1 or 2, above, divided by a safety factor of at least 2.

With the torque correlation method, the ultimate axial soil capacity (P_{ult}) of the pile and the allowable axial soil capacity (P_a) of the pile are predicted as follows:

$$P_{\text{ult}} = K_t \times T \quad (\text{Equation 1})$$

$$P_a = 0.5 P_{\text{ult}} \quad (\text{Equation 2})$$

where:

P_{ult} = Ultimate axial compressive capacity (lbf or N) of helical pile, which must be limited to the maximum ultimate values noted in Table 4.

P_a = Allowable axial compression capacity (lbf or N) of helical piles, which must be limited to the maximum allowable values noted in Table 4.

K_t = Torque correlation factor per Table 4.

T = Final installation torque defined as the last torque reading taken when terminating the helical pile installation; which must not exceed the maximum installation torque rating noted in Table 4 of this report.

Tension and lateral soil capacities are outside the scope of this report and should be determined by a registered design professional on a project by project basis and subjected to approval of the code official.

4.2 Installation:

4.2.1 General: The PierTech helical foundation systems must be installed by PierTech trained and authorized installers. The PierTech helical foundation systems must be installed in accordance with this section (Section 4.2), IBC Section 1810.4.11, the site-specific approved construction documents (engineering plans and specifications), and the manufacturer's written installation instructions. In case of conflict, the most stringent requirement governs.

4.2.2 Helical Piles: The helical piles must be installed according to a preapproved plan of placement. Installation begins by attaching the helical pile lead section to the torque motor (drive head) using a drive tool and drive pin. Next, crowd must be applied to force the pilot point into the ground at the proper location, inclination and orientation, as described in the placement plan. Then the pile must be rotated into the ground in a smooth, clockwise, continuous manner while maintaining sufficient crowd to promote normal advancement (approximately 3 inches per revolution). Installation continues by adding extension sections as necessary. Refer to Sections 3.2.1 and 3.3.6 of this report and the approved construction documents for type, grade, size and number of bolts and nuts that are required to connect the shaft sections. Inclination and alignment shall be checked and adjusted periodically during installation. Connection bolts between shaft sections shall be snug-tightened as defined in Section J3 of AISC 360. Care shall be taken not to exceed the maximum installation torque rating, as shown in Table 4, of the helical piles during installation. Helical piles must be advanced until axial capacity is verified by achieving the required final installation torque as indicated by the torque correlation method described in Section 4.1.5, and the minimum depth, if any, as specified by the geotechnical report Section 4.1.1.

4.2.3 Type A Side Load Brackets: Type A brackets must be installed as specified in the approved plans. Installation of brackets requires an area adjacent to the building foundation to be excavated at each location thus exposing the footing, column pad, or grade beam. The area to be exposed should be an approximate width of 18 inches and should extend below the bottom of the footing or grade beam by approximately 12 inches. Any soil attached to the bottom of the footing, column pad, or grade beam should be removed prior to bracket installation. The footing or grade beam must be prepared by chipping away the irregularities from the side or bottom for a sure bracket attachment. Existing concrete footing or grade beam capacity must not be altered, such as notching of concrete or cutting of reinforcing steel, without the approval of the registered design professional and the code official. Prepping of the footing allows for the bracket to be mounted to a reasonably flat,

smooth, and full bearing surface. Once the pile has been installed to the design load, the bracket shelf is rotated into place under the existing concrete footing, column pad, or grade beam. Any excess pile length will be cut off level, above the bracket several inches, to enable the mounting of the bracket. The T-bracket will be placed into the top helical pile and bracket assembly. The threaded rods, hex nuts and washers, supplied with the bracket, are added to hold the bracket in position. The hex nuts shall be snug tightened, as defined in Section J3 of AISC 360. A jacking block bracket, and lifting jack are installed to raise the foundation to the desired elevation. Any lifting of the existing structure must be verified by a registered design professional and is subjected to approval of the code official to ensure that the foundation, superstructure, and helical piles are not overstressed. Once the foundation has been raised to its desired elevation, the hex nuts over the T-bracket are tightened, and the jacking brackets and lifting jacks are removed. Cut off the excess thread rod, which was used for lifting, from above the bracket assembly. The field cutting and bolting must be in accordance with the most restrictive requirements as described in the evaluation report, the IBC, AISC 360, and the manufacturer's written instructions. The excavation must be backfilled in accordance with 2015, 2012, and 2009 IBC Section 1804.

4.2.4 Type B Direct Load Brackets: Type B brackets must be placed over the top of the helical piles. The top of the pile elevation must be established and must be consistent with the specified elevation. If necessary, the top of the pile may be cut off level to the required length in accordance with the manufacturer's instructions and AISC 360 requirements so as to ensure full, direct bearing contact between the top of the pile shaft and the bracket. In the case of Type B bracket, two ¾-inch-diameter (19 mm) bolts and hex nuts as described in Section 3.3.6 of this report may be installed for helical piles under compression. The bolts must be snug-tightened, as defined in Section J3 of AISC 360. The embedment and edge distance of the bracket into the concrete foundation must be as described in the approved plans and as indicated in Table 1 of this report. The concrete foundation must be cast around the bracket in accordance with the approved construction documents.

4.3 Special Inspection:

Special inspections in accordance with 2015 and 2012 IBC Section 1705.9 (2009 IBC Section 1704.10) must be performed continuously during installation of PierTech helical foundation systems (piles and brackets). Items to be recorded and confirmed by the special inspector must include, but are not be limited to, the following:

1. Verification of the product manufacturer, the manufacturer's certification of installers.
2. Product identification including lead sections, couplings, extension sections, brackets, bolts and nuts, as specified in the construction documents and this evaluation report.
3. Installation equipment used.
4. Written installation procedures.
5. Tip elevations, the installation torque and final depth of the helical foundation systems.
6. Inclination and position/location of helical piles.
7. Tightness of all bolted connections.

8. Verification that direct load bracket cap plates are in full contact with the top of the pile shaft.
9. Compliance of the installation with the approved construction documents and this evaluation report.

5.0 CONDITIONS OF USE

The PierTech helical foundation systems described in this report, comply with or are suitable alternative to what is specified in, the code listed in Section 1.0 of this report, subject to the following conditions:

- 5.1 The PierTech helical foundation systems are manufactured identified and installed in accordance with this report, the site-specific approved construction documents (engineering plans and specifications), IBC Section 1810.4.11, and the manufacturer's written installation instructions. In case of conflict, the most stringent requirement governs.
- 5.2 The PierTech helical foundation systems have been evaluated for support of structures assigned to Seismic Design Categories A, B and C in accordance with IBC Section 1613. Helical foundation systems that support structures assigned to Seismic Design Category D, E or F, or that are located in Site Class E or F, are outside the scope of this report, and are subject to the approval of the code official based upon submission of a design in accordance with the code by a registered design professional.
- 5.3 Type A (Side Load) and Type B (Direct Load) brackets are limited to compression loads only.
- 5.4 Type A (Side Load) and Type B (Direct Load) brackets must be used only to support structures that are laterally braced as defined in IBC Section 1810.2.2. Shaft couplings must be located within firm or soft soil as defined in Section 4.1.3.
- 5.5 The installations of Type A (Side Load) and Type B (Direct Load) brackets are limited to regions of concrete members where analysis indicates no cracking at service load levels.
- 5.6 The PierTech helical foundation systems must not be used in conditions that are indicative of potential pile deterioration or corrosion situations as defined by the following: (1) soil resistivity less than 1,000 ohm-cm; (2) soil pH less than 5.5; (3) soils with high organic content; (4) soil sulfate concentrations greater than 1,000 ppm; (5) soils located in landfill, or (6) soil containing mine waste.
- 5.7 Zinc-coated steel and bare steel components must not be combined in the same system. All helical foundation components must be galvanically isolated from concrete reinforcing steel, building structural steel, or any other metal building components.
- 5.8 The helical piles must be installed vertically into the ground with the maximum allowable angle of inclination of 1 degree.
- 5.9 Engineering calculations and drawings, in accordance with recognized engineering principles, as described in IBC Section 1604.4, and complying with Section 4.1 of this report, prepared by a registered design professional, are provided to, and are approved by the code official.
- 5.10 The adequacy of the concrete structures that are connected to the PierTech brackets must be

verified by a registered design professional, in accordance with applicable code provisions, such as Chapter 15 of ACI 318 and Chapter 18 of IBC, and subject to the approval of the code official.

- 5.11 A geotechnical investigation report for each project site in accordance with Section 4.1.1 of this report must be provided to the code official for approval.
- 5.12 Special inspection is provided in accordance with Section 4.3 of this report.
- 5.13 When using the alternative basic load combinations prescribed in IBC Section 1605.3.2, the allowable stress increases permitted by material chapters of the IBC or the referenced standards are prohibited.
- 5.14 The applied loads must not exceed the allowable capacities described in Section 4.1 of this report.
- 5.15 The minimum helical pile center-to-center spacing upon which this evaluation report is based is four times the average helical bearing plate diameters. For piles with closer spacing, the pile allowable load reductions due to pile group effects must be included in the geotechnical report, described in Section 4.1.1 of this report, and must be considered in the pile design by a registered design professional, and subject to the approval of the code official.
- 5.16 Requirements described in footnotes of tables in this report must be satisfied.

5.17 Evaluation of compliance with IBC Section 1810.3.11.1 for buildings assigned to Seismic Design Category (SDC) C, and with IBC Section 1810.3.6 for all buildings, is outside of the scope of this evaluation report. Such compliance must be addressed by a registered design professional for each site, and is subject to approval by the code official.

5.18 Settlement of helical piles is beyond the scope of this evaluation report and must be determined by a registered design professional as required in IBC Section 1810.2.3.

5.19 The PierTech helical foundation systems are manufactured in Cokato, Minnesota, under a quality-control program with inspections by ICC-ES.

6.0 EVIDENCE SUBMITTED

Data in accordance with the ICC-ES Acceptance Criteria for Helical Pile Systems and Devices (AC358), dated October 2016.

7.0 IDENTIFICATION

The PierTech Systems, LLC (PierTech) helical foundation systems (including lead shafts, extension shafts, brackets, and boxed hardware) are identified by a tag or label bearing the logo, name, and address of PierTech, the product number, and the evaluation report number (ESR-3969).

TABLE 1—BRACKET CAPACITY (P1) FOR DIRECT LOAD BRACKETS

BRACKET TYPE	PRODUCT NUMBER	SHAFT DIAMETER (inches)	(P1) ALLOWABLE CAPACITY (kips)		
			2,500 psi Concrete Minimum		
			Compression	Tension	Lateral
Type A (Side Load) Bracket	2.88-TLB	2 ⁷ / ₈	27.9	N/A	N/A
Type B ^{1,2} (Direct Load) Bracket	2.88-NCB	2 ⁷ / ₈	43.5 ³	N/A	N/A

For SI: 1 kip = 4.448 kN, 1 psi = 6.895 kPa.

¹Only localized limit states of supporting concrete including bearing and 2-way punching shear have been evaluated. Refer to Sections 5.4 and 5.9 of this report for additional requirements.

²Allowable capacities include an allowance for corrosion over a 50-year service life and presume the supported structure is braced in accordance with IBC Section 1810.2.2.

³The allowable compressive load capacity is based on the mechanical strength of the steel bracket, concrete punching shear capacity, and concrete bearing strength. The allowable load capacities have been determined assuming that minimum reinforcement has been provided as specified by ACI 318-14 Section 9.6.1.2 and ACI 318-11 Section 10.5.1. The minimum embedment of the bracket is 11.30-inches. The embedment depth is the distance between the top of the bracket plate to the top of the concrete footing. The end of helical pile shaft must be fully bearing on bracket plate. For Type B bracket, the concrete footing must have a minimum thickness of 15.8-inches and a minimum width of 28.6-inches, and must be normal-weight concrete having a minimum compressive strength of 2,500 psi.

TABLE 2(A)—2⁷/₈-INCH SHAFT ALLOWABLE CAPACITY (P2)¹

UNBRACED SHAFT LENGTH, kL (FT)	(P2) ALLOWABLE CAPACITY (KIPS)				
	COMPRESSION ^{2,3}			TENSION	LATERAL
	0 Coupler	1 Coupler	2 Couplers		
0	50	21.3	10.8	NE ⁴	NE ⁴
5	18.0	12.9	6.5	NE ⁴	NE ⁴
10	7.9	6.7	5.0	NE ⁴	NE ⁴

For SI: 1 inch = 25.4 mm, 1 kip = 4.448 kN.

¹Allowable capacities include an allowance for corrosion over a 50-year service life.

²Allowable capacities are based on fully braced conditions where effective length (kL) of piles equals to zero and pile tops are fully braced, which require the pile head to be fully braced laterally and rotationally and no portion of shaft is in air, water, or fluid soils. Refer to Section 4.1.3 of this report for the determination of unbraced length, L.

³For other unbraced lengths, the shaft capacity of helical foundations must be determined by a registered design professional.

⁴NE = Not evaluated at this time.

TABLE 2(B)—MECHANICAL PROPERTIES AFTER CORROSION LOSS¹ OF 2.875-INCH DIAMETER HELICAL SHAFT

MECHANICAL PROPERTIES	2.875-INCH (0.217-INCH WALL THICKNESS)
Steel Yield Strength, F _y (ksi)	60
Steel Ultimate Strength, F _u (ksi)	63
Modulus of Elasticity, E (ksi)	29,000
Nominal Wall Thickness (inch)	0.217
Design Wall Thickness (inch)	0.166
Outside Diameter (inch)	2.839
Inside Diameter (inch)	2.507
Cross Sectional Area (inch ²)	1.39
Moment of Inertia, I (inch ⁴)	1.25
Radius of Gyration, r (inch)	0.95
Section Modulus, S (inch ³)	0.88
Plastic Section Modulus, Z (inch ³)	1.19

For SI: 1 inch = 25.4 mm; 1 ksi = 6.89 MPa, 1 ft-lbf = 1.36 N-m; 1 lbf = 4.45 N.

¹Dimensional properties are based on bare steel losing 0.036-inch steel thickness as indicated in Section 3.9 of AC308 for a 50-year service life.

TABLE 3—HELICAL BEARING PLATE CAPACITY (P3) – AXIAL COMPRESSION^{1,2,3}

HELIX DIAM. (IN)	HELIX THICKNESS (IN)	HELIX PITCH (IN)	ALLOWABLE CAPACITY ³ (P3) (KIPS)
8	0.375	3.0	63.4
10	0.375	3.0	59.3
12	0.375	3.0	62.6
14	0.375	3.0	65.4

For **SI**: 1 inch = 25.4 mm, 1 kip = 4.448 kN.

¹For helical piles with more than one helix, the allowable helix capacity, P3, for the helical foundation systems, may be taken as the sum of the least allowable capacity of each individual helix.

²As described in Section 3.2.1 of this report, all helical bearing plates are made from same material, and have the same edge geometry, thickness and pitch.

³Allowable capacities include an allowance for corrosion over a 50-year service life.

TABLE 4—SOIL CAPACITY (P4) – AXIAL COMPRESSION¹

GEOTECHNICAL RELATED PROPERTIES	2 ⁷ / ₈ -INCH HELICAL PILE
Mechanical Torsion Rating of shaft and helical plate (ft-lbs) ³	8,840
Maximum Torque Per Soil Tests (ft-lbs) ⁴	8,840
Maximum Installation Torque Rating (ft-lbs) ⁵	8,840
Torque Correlation Factor, K _t (ft ⁻¹)	9
Maximum Ultimate Soil Capacity / Maximum Allowable Soil Capacity (P4) from Torque Correlations (kips) ²	79.6/39.8

For **SI**: 1 foot = 0.305 m, 1 lbf = 4.448 N, 1 lbf-ft = 1.356 N-m.

¹Soil capacity (P4) must be determined per Section 4.1.5 of this report.

²Maximum ultimate soil capacity is determined from $P_{ult} = K_t \times T$ based on the corresponding maximum installation torque rating for the specific pile model. Allowable soil capacity is determined from $P_a = P_{ult} / 2.0$ based on the corresponding maximum installation torque rating for the specific pile model. See Section 4.1.5 for additional information.

³Mechanical torsion rating is the maximum torsional resistance of the steel shaft.

⁴Maximum Torque Per Soil Tests is the maximum torque achieved during field axial verification testing that was conducted to verify the pile axial capacity related to pile-soil interaction.

⁵Maximum Installation Torque rating is the lower of the “mechanical torsion rating” and the “maximum torque per soil tests”.

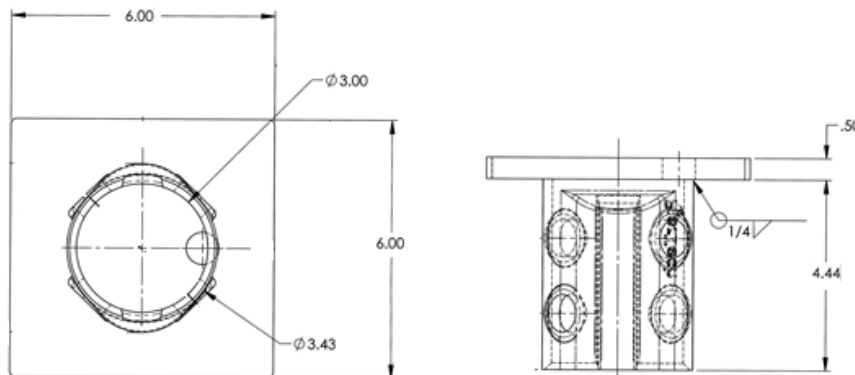

FIGURE 1—NEW CONSTRUCTION BRACKET (NCB)

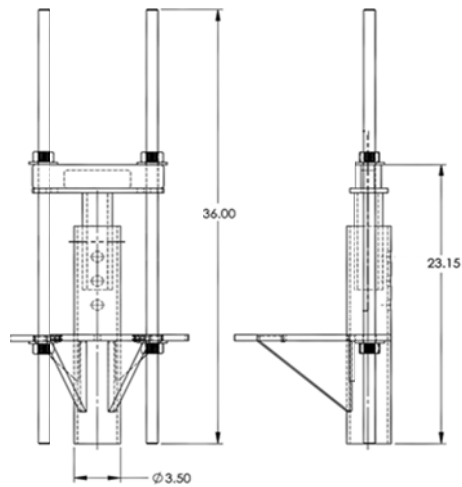
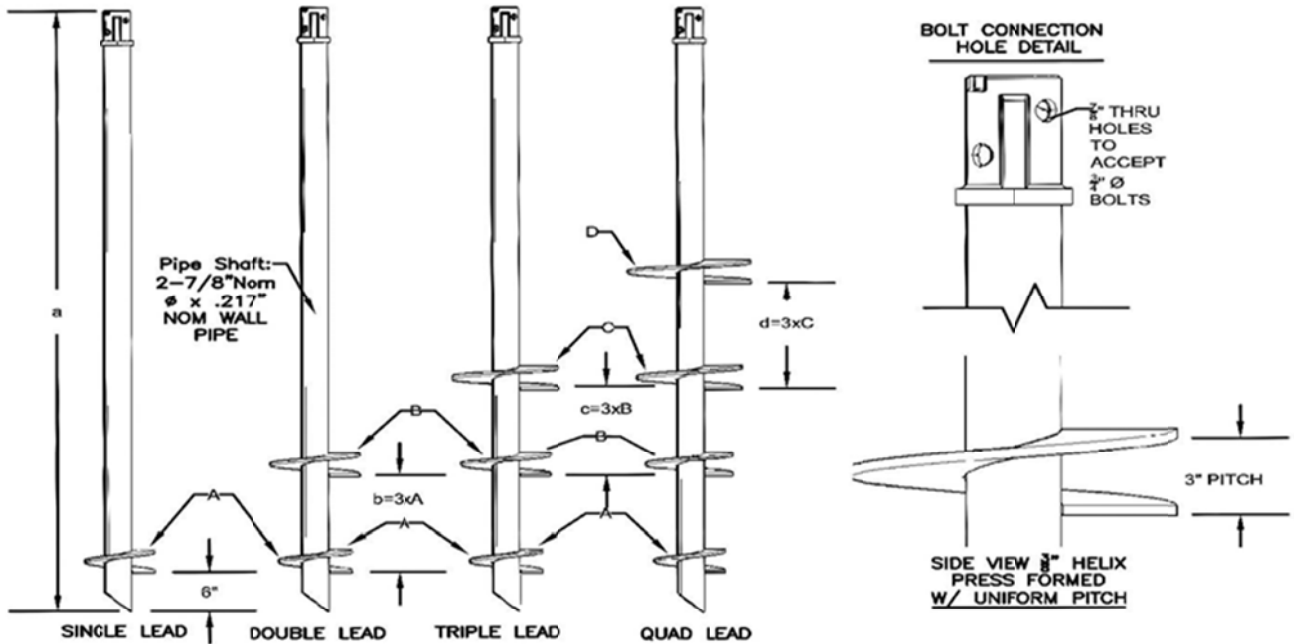

FIGURE 2—TRU-LIFT BRACKET (TLB)



<i>Common Lead Configurations</i>								
NO.	Dimensions(IN)				Helix Diamters(IN)			
	a	b	c	d	A	B	C	D
2.88-L710G	84				10			
2.88-L712G	84				12			
2.88-L7810G	84	24			8	10		
2.88-L71012G	84	30			10	12		
2.88-L781012G	84	24	30		8	10	12	
2.88-L10101214G	120	30	36		10	12	14	
2.88-L108101214G	120	24	30	36	8	10	12	14

All dimensions in inches. Other lead configurations, helix sizes, and pitches are available upon request.

FIGURE 3—HELICAL LEAD SHAFTS

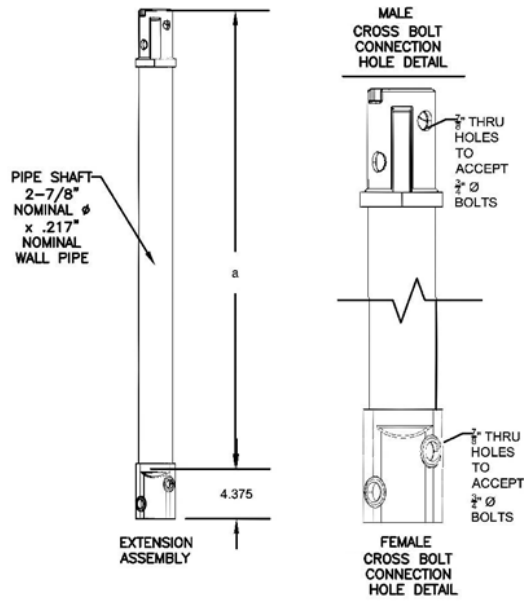

<i>Common Extension Configurations</i>							
NO.	a						
2.88-E5G	60						
2.88-E7G	84						
2.88-E10G	120						
All dimensions in inches. Other extension lengths are available upon request.							

FIGURE 4—HELICAL EXTENSION SHAFTS

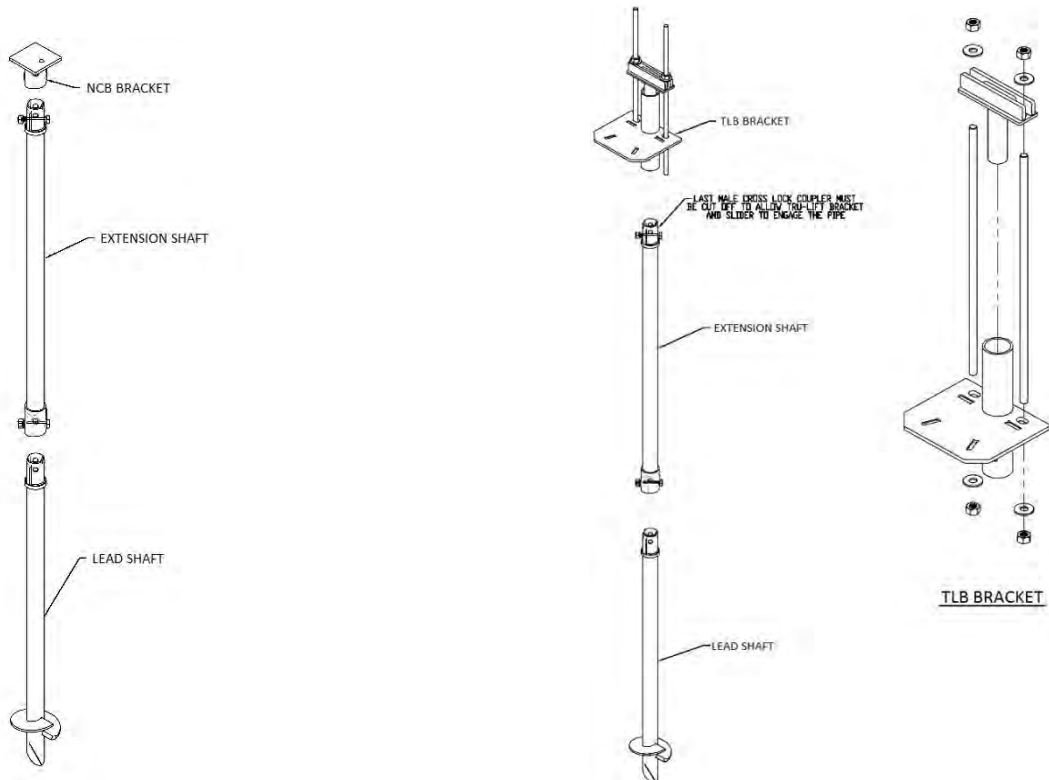

NEW CONSTRUCTION HELICAL PIER ASSEMBLY

REPAIR HELICAL PIER ASSEMBLY

FIGURE 5—HELICAL PIER ASSEMBLY