



ICC Evaluation Service, Inc.
www.icc-es.org

Business/Regional Office ■ 5360 Workman Mill Road, Whittier, California 90601 ■ (562) 699-0543
Regional Office ■ 900 Montclair Road, Suite A, Birmingham, Alabama 35213 ■ (205) 599-9800
Regional Office ■ 4051 West Flossmoor Road, Country Club Hills, Illinois 60478 ■ (708) 799-2305

Legacy report on the BOCA® National Building Code/1999 and the 1997 International Plumbing Code®

DIVISION: 02—SITWORK
Section: 02620—Subdrainage

REPORT HOLDER:

BASEMENT SYSTEMS INC.
60 SILVERMINE ROAD
SEYMOUR, CONNECTICUT 06483
www.basementsystems.com

EVALUATION SUBJECT:

WATERGUARD® SUBFLOOR DRAINAGE SYSTEM

EVALUATION SCOPE:

Compliance with the following codes:

BOCA® National Building Code/1999

- Section 1710.1 General

SUBSOIL DRAINAGE SYSTEM

1997 International Plumbing Code®

- Section 105.2 Alternative materials, methods and equipment
- Section 1111.1 Subsoil drains
- Section 1111.2 Building subdrains

BOCA® National Building Code/1999

- Section 106.4 Alternative materials and equipment
- Section 1813.5 Subsoil drainage system

DESCRIPTION

WaterGuard® Subfloor Drainage System is a subsurface drainage system, consisting of a polyvinyl chloride (PVC) drain pipe, a PVC drain outlet, and crushed stone. The system is located below the interior concrete slab of a below grade story or basement floor and on top of the foundation wall footing. The WaterGuard® Subfloor Drainage System is intended for use with foundation walls of concrete masonry units, rubble stone, brick or cast-in-place concrete construction. See Figures 1 and 2 of this report for illustrations of the Water-Guard® Subfloor Drainage System when used with a concrete masonry unit foundation wall and a cast-in-place concrete foundation wall, respectively.

When used with a concrete masonry unit foundation wall, the system functions by collecting water or moisture permeating through the wall assembly or through weep holes placed on the

inside face of concrete masonry units. The water is then discharged from the system by gravity or mechanical means.

When used with rubble stone, brick or cast-in-place concrete foundation walls, the drainage system is to be supplementary to a foundation drain. In applications where water permeates through the rubble stone, brick or cast-in-place concrete foundation wall, the drainage system is intended to discharge the water as described above for concrete masonry unit foundation walls.

WaterGuard® Subfloor Drainage System Components

- **Drain channel:** A 0.1-inch-thick (2.54 mm), one-piece construction of extruded, solid polyvinyl chloride (PVC). Drainage holes, 0.75-inch-diameter (19.1 mm) and 3 inch (76 mm) on center, are located at the base of the channel on the side facing the foundation wall.

The component cross section is a 3.13-by-1.85 inch (80×47 mm) rectangle with a 2.43 inch (62 mm) flange on top. Two 0.35-inch-long (8.89 mm) spacers are attached to the flange on the side facing the foundation wall. The spacers are intended to provide a means of directing the flow of moisture which may penetrate the foundation wall. See Figure 3 at the end of this report for an illustration of the drain channel component.

- **Drain outlet:** A 0.1-inch-thick (2.54 mm), one-piece construction of extruded, solid polyvinyl chloride (PVC) that is friction-fit to the drain channel component. The component cross section is a 3.13-by-1.85 inch (80×47 mm) rectangle with a 2.43 inch (62 mm) flange on top. The component extends at the base to accommodate a 4-inch-diameter (102 mm) drain opening. The drain opening is intended to be located at the point where the WaterGuard® Subfloor Drainage System is attached to a drain or sump. See Figure 4 at the end of this report for an illustration of the drain outlet component.

- **Crushed stone:** Minimum 0.5-inch-diameter (12.7 mm) crushed stone shall be placed on one side of the drain channel with the side facing the footing left free of stone to allow an air space to exist between the footing and channel.

CONDITIONS OF USE

This report is limited to the applications and products as stated in this report. The ICC-ES Subcommittee on National Codes intends that the report be used by the code official to determine that the report subject complies with the code requirements specifically addressed, provided that this product is installed in accordance with the following conditions:

ICC-ES legacy reports are not to be construed as representing aesthetics or any other attributes not specifically addressed, nor are they to be construed as an endorsement of the subject of the report or a recommendation for its use. There is no warranty by ICC Evaluation Service, Inc., express or implied, as to any finding or other matter in this report, or as to any product covered by the report.

- The WaterGuard® Subfloor Drainage System shall be installed in accordance with the manufacturer's installation instructions and the limitations of this report.
- The footing shall not be undermined under any circumstances during the excavation required for the installation of the WaterGuard® Subfloor Drainage System.
- The WaterGuard® Subfloor Drainage System shall not be installed where the load-resisting capability of the wall is not adequate or is jeopardized by the excavation and/or installation.
- Evaluation of the WaterGuard® Subfloor Drainage System when utilized with a rubble stone, brick or cast-in-place concrete foundation wall is limited to installations that comply with Section 1813.5.2 of the BOCA® *National Building Code/1999*.
- The WaterGuard® Subfloor Drainage System is limited to applications where the ground water table investigation determines that a subsoil drainage system is required by the code.
- For installation with foundation walls constructed of concrete masonry units, a maximum of one $\frac{5}{8}$ -inch-diameter (15.9 mm) weep hole shall be drilled in each core of every block in the bottom course of blocks.
- This report is subject to periodic re-examination. For information on the current status of this report, contact the ICC-ES.

APPLICATION FOR PERMIT

To aid in the determination of compliance with this report, the following represents the minimum level of information to accompany the application for permit:

- The language "See ICC-ES Legacy Report No. 98-63" or a copy of this report;
- Type of foundation wall construction;
- Method for disposal of water from the system;
- Instructions regarding investigations of the load carrying capacity of the wall to determine adequacy;
- Specifications for all destructive operations; and
- Specifications for location, number, and size of weep holes in concrete masonry unit foundations.

INFORMATION SUBMITTED

- VTEC Laboratories, Inc., Test Report No. 100-886, dated October 22, 1998, containing results of physical testing performed in accordance with Section 1710.3 of the BOCA® *National Building Code/1999*.
- VTEC Laboratories, Inc., Test Report No. 100-950, dated March 11, 1999, containing results of structural testing performed on concrete masonry units with and without drainage holes.

ITEMS REQUIRING VERIFICATION

- ✓ Water which drains into this drainage system shall be collected and disposed of in accordance with the 1997 *International Plumbing Code*®. The collection and disposal system shall be installed in accordance with the 1997 *International Plumbing Code*®.

- ✓ The floor shall be resurfaced with concrete meeting the minimum requirements as set forth in Sections 1905.0, 1906.0, 1907.0, and 1908.0 of the BOCA® *National Building Code/1999*.
- ✓ Methods required to enhance the capacity or stability of the foundation system, including modifications and repairs of structural cracks in existing foundation walls, shall be determined by a registered design professional and are outside the scope of this report.

PRODUCT IDENTIFICATION

All Basement Systems Inc., WaterGuard® Subfloor Drainage System components, or their packaging, manufactured in accordance with this report shall bear the following identification:

- "See ICC-ES Legacy Report No. 98-63."
- Manufacturer's name and product name.

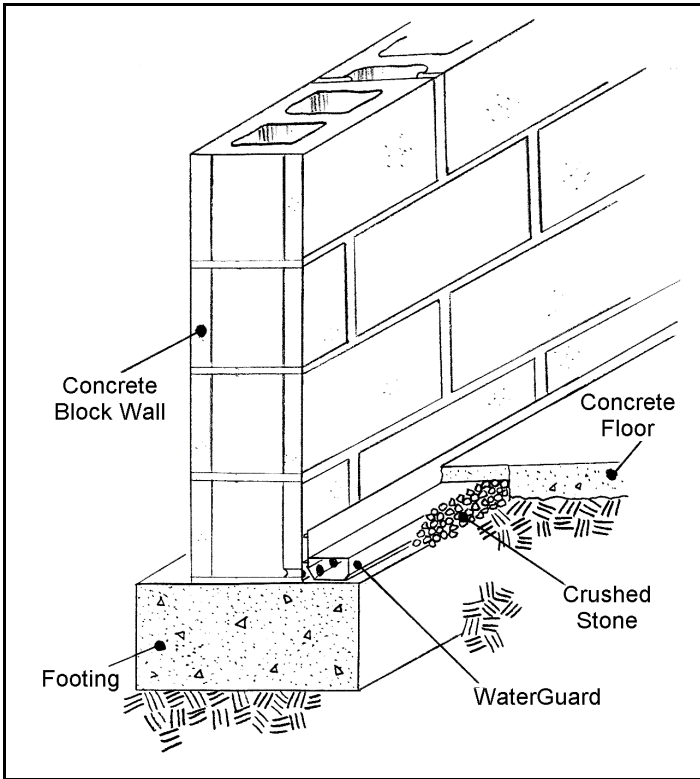

FIGURE 1*—WATERGUARD® SUBFLOOR DRAINAGE SYSTEM
CONCRETE MASONRY UNIT FOUNDATION WALL

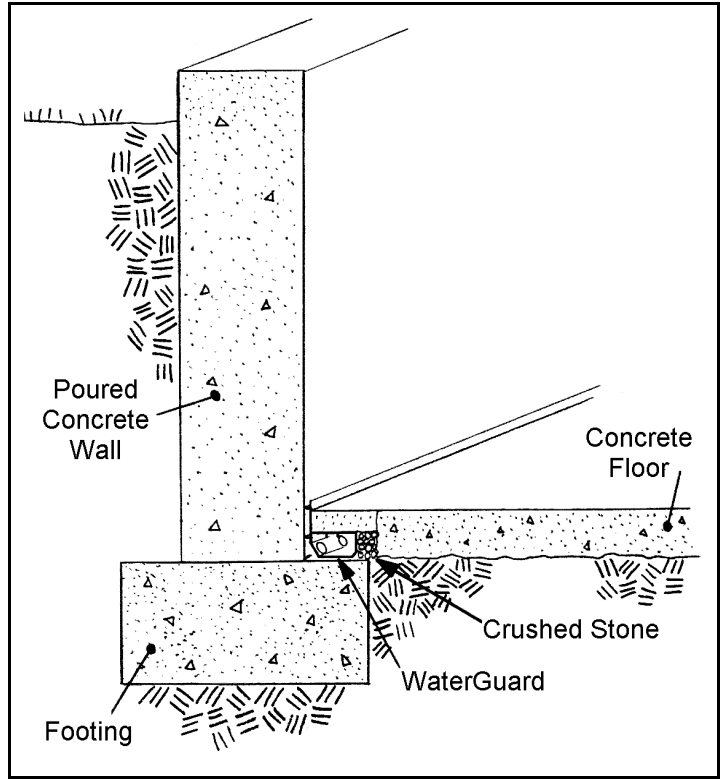
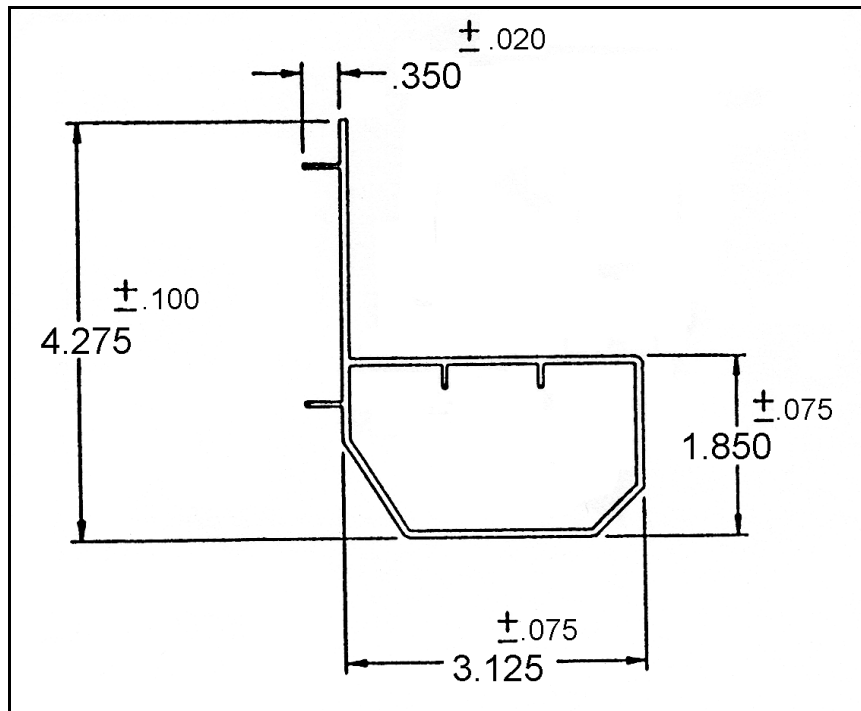

FIGURE 2*—WATERGUARD® SUBFLOOR DRAINAGE SYSTEM
CAST-IN-PLACE CONCRETE FOUNDATION WALL



For SI: 1 inch = 25.4 mm

FIGURE 3*—DRAIN CHANNEL COMPONENT

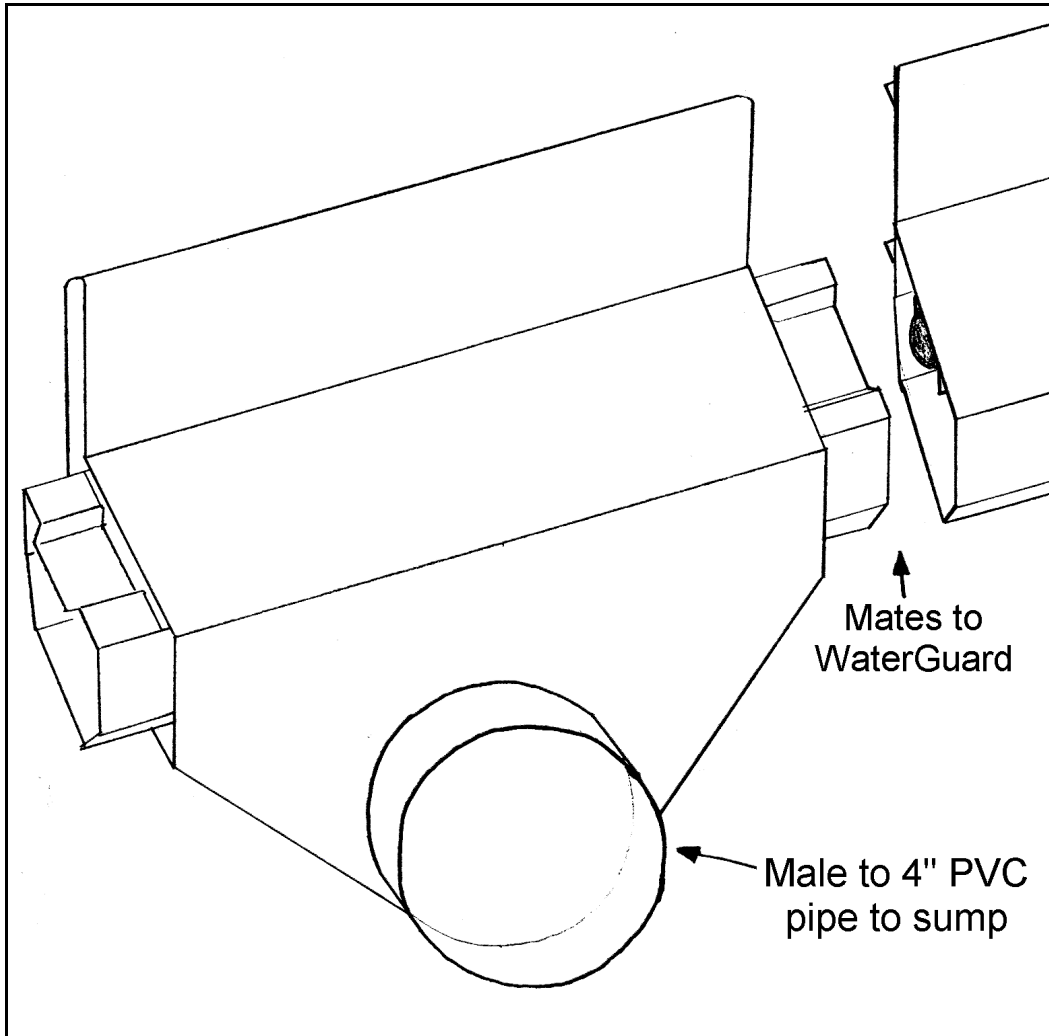

FIGURE 4*—DRAIN OUTLET COMPONENT

*THESE DRAWINGS ARE FOR ILLUSTRATION PURPOSES ONLY. THEY ARE NOT INTENDED FOR USE AS CONSTRUCTION DOCUMENTS FOR THE PURPOSE OF DESIGN, FABRICATION OR ERECTION.