



Most Widely Accepted and Trusted

ICC-ES Evaluation Report

ESR-2024

ICC-ES | (800) 423-6587 | (562) 699-0543 | www.icc-es.org

Reissued 09/2017
This report is subject to renewal 09/2018.

DIVISION: 03 00 00—CONCRETE
SECTION: 03 15 00—CONCRETE ACCESSORIES
SECTION: 03 16 00—CONCRETE ANCHORS
DIVISION: 05 00 00—METALS
SECTION: 05 05 23—METAL FASTENINGS
DIVISION: 06 00 00—WOOD, PLASTICS AND COMPOSITES
SECTION: 06 05 23—WOOD, PLASTIC, AND COMPOSITE FASTENINGS
DIVISION: 09 00 00—FINISHES
SECTION: 09 22 16.23—FASTENERS

REPORT HOLDER:

DEWALT

701 EAST JOPPA ROAD
TOWSON, MARYLAND 21286

EVALUATION SUBJECT:

POWER-DRIVEN FASTENERS, CEILING CLIP ASSEMBLIES AND SILL PLATE ANCHORAGES (DEWALT / POWERS)



Look for the trusted marks of Conformity!

“2014 Recipient of Prestigious Western States Seismic Policy Council (WSSPC) Award in Excellence”



ICC-ES Evaluation Reports are not to be construed as representing aesthetics or any other attributes not specifically addressed, nor are they to be construed as an endorsement of the subject of the report or a recommendation for its use. There is no warranty by ICC Evaluation Service, LLC, express or implied, as to any finding or other matter in this report, or as to any product covered by the report.



ICC-ES Evaluation Report

ESR-2024

Reissued September 2017

This report is subject to renewal September 2018.

www.icc-es.org | (800) 423-6587 | (562) 699-0543

A Subsidiary of the International Code Council®

DIVISION: 03 00 00—CONCRETE

Section: 03 15 00—Concrete Accessories

Section: 03 16 00—Concrete Anchors

DIVISION: 05 00 00—METALS

Section: 05 05 23—Metal Fastenings

DIVISION: 06 00 00—WOOD, PLASTICS AND COMPOSITES

Section: 06 05 23—Wood, Plastic and Composite Fastenings

DIVISION: 09 00 00—FINISHES

Section: 09 22 16.23—Fasteners

REPORT HOLDER:

DEWALT

701 EAST JOPPA ROAD
TOWSON, MARYLAND 21286
(800) 524-3244

www.dewalt.com
engineering@powers.com

ADDITIONAL LISTEE:

POWERS FASTENERS

701 EAST JOPPA ROAD
TOWSON, MARYLAND 21286
(800) 524-3244

www.powers.com
engineering@powers.com

MAX CO., LTD.

6-6 NIHONBASHI-HAKAZAKI-CHO
CHUO-KU, TOKYO
JAPAN
+ (03) 3669-8131

EVALUATION SUBJECT:

POWER-DRIVEN FASTENERS, CEILING CLIP ASSEMBLIES AND SILL PLATE ANCHORAGES (DEWALT / POWERS)

1.0 EVALUATION SCOPE

Compliance with the following codes:

- 2015, 2012 and 2009 *International Building Code*® (IBC)
- 2015, 2012 and 2009 *International Residential Code*® (IRC)

Property evaluated:

Structural

2.0 USES

The power-actuated fasteners (PAFs) used to attach building elements, such as wood and cold-formed steel, to base materials of: uncracked, normalweight and sand-lightweight concrete; cold-formed steel decks with sand-lightweight concrete fill; and structural steel.

The fasteners, which include pins and threaded studs, are alternatives to the cast-in-place anchors described in 2015 IBC Section 1901.3 (2012 IBC Section 1908; 2009 IBC Section 1911) for placement in concrete; and the welds and bolts used to attach materials to steel described in IBC Sections 2204.1 and 2204.2, respectively.

Select fasteners are alternatives to the cast-in-place anchors described in 2015 IBC Section 2308.3.1 (2012 and 2009 IBC Section 2308.6) and IRC Section R403.1.6 for anchorage of wood sills to concrete.

The fasteners are also used as components of the ceiling clip assemblies, which are used to fasten suspended ceiling systems to the supporting structure, and for sill plate anchorage.

For structures regulated under the IRC, the fasteners may be used where an engineered design is submitted in accordance with IRC Section R301.1.3.

3.0 DESCRIPTION

3.1 Power-driven Fasteners:

The power-driven fasteners are low-velocity power-actuated fasteners (PAFs) manufactured from hardened steel complying with the manufacturer's quality documentation; and are zinc-plated in accordance with ASTM B695, Class 5, Type 1 unless otherwise noted. Product names for the report holder and additional listees are presented in Table A of this report. See Figure 3 for images of the fasteners. See Table B for dimensional properties.

3.1.1 0.300-inch Head Drive Pins: These fasteners have a head diameter of 0.300-inch (7.62 mm) and either a smooth or knurled shank with a diameter of 0.145 inch (3.7 mm). The single fasteners have premounted plastic guide washers. These fasteners are also available with premounted top hat washers. The mechanically galvanized (MG) version of these fasteners have premounted plastic guide washers and are zinc-plated in accordance with ASTM B695, Class 55.

3.1.2 8 mm Head Drive Pins: These fasteners have a head diameter of 8 mm (0.315 inch), a smooth or knurled shank with a diameter of 0.145 inch (3.7 mm). The single fasteners have premounted plastic guide washers. These

fasteners are also available with premounted top hat washers or in collated strips.

3.1.3 CSI Spiral Pins (8 mm Head): These fasteners have a head diameter of 8 mm (0.32 inch) and a spiral shank with a diameter of 0.157 inch (4.0 mm). The single fasteners have premounted plastic guide washers. These fasteners are also available in collated strips.

3.1.4 CSI Spiral Step Shank Pin (8 mm Head): These fasteners have a head diameter of 8 mm (0.32 inch); and a stepped, spiral shank with diameters of 0.145 and 0.125 inch (3.7 and 3.2 mm). The single fasteners have premounted plastic guide washers. These fasteners are also available in collated strips.

3.1.5 Ballistic Point Drive Pins: These fasteners have a head diameter of 0.300 inch (7.62 mm) and a smooth shank with a diameter of 0.150 inch (3.8 mm). Single fasteners have a premounted plastic guide washer. The fasteners are coated with a black polymer.

3.1.6 Threaded Studs: These fasteners have a smooth shank at the end that is power-driven into the substrate and threads at the other end. The threaded studs are available with $1/4$ -inch-20 or $3/8$ -inch-16 thread diameters with a variety of thread and shank lengths. The $1/4$ -inch-20 threaded studs have a smooth shank diameter of 0.145 inch (3.7 mm), while the $3/8$ -inch-16 threaded studs have a smooth shank diameter of 0.205 inch (5.2 mm). The single fasteners have a premounted plastic guide washer.

3.2 Ceiling Clip Assemblies:

The power-driven ceiling clip assemblies are comprised of a power-driven fastener with a premounted steel angle clip for attachment of ceiling wire or a premounted steel clip with a post-nut accessory for attachment of threaded rod. The assemblies may also include premounted washers. The clips are manufactured from carbon steel and are zinc-plated in accordance with ASTM B695, Class 5, Type 1. See Figure 5 for images of the ceiling clip assemblies.

3.2.1 0.300-inch Head Drive Pin Ceiling Clip Assemblies: Both standard and economy ceiling clip assemblies are available and are comprised of the smooth shank head drive pins, described in Section 3.1.1 and a standard or economy clip, respectively. The standard clips have a 90 degree angle and are manufactured from 0.080-inch-thick (2.0 mm) steel. The economy clips have a 30-degree angle and are manufactured from 0.075-inch-thick (1.9 mm) steel.

3.2.2 8 mm Head Drive Pin Ceiling Clip Assemblies: The assemblies are comprised of the smooth shank head drive pins described in Section 3.1.2 and the standard ceiling clip described in Section 3.2.1.

3.2.3 CSI Spiral Pin Ceiling Clip Assemblies (8 mm Head): The assemblies are comprised of the spiral shank pin described in Section 3.1.3 and a 90-degree angle clip manufactured from 0.079-inch-thick (2.0 mm) steel.

3.2.4 LADD Ceiling Clip Assembly: The LADD ceiling clip assembly is intended for use with LADD-type tools. The fastener is manufactured from steel complying with ASTM A510, Grade 1060, and austempered to a Rockwell C 53 to 55 core hardness. The fastener has a head diameter of 0.310 inch (7.87 mm) and a shank diameter of 0.152 inch (3.86 mm). The fastener is zinc-plated in accordance with ASTM B695. The clips have a 45-degree angle and are manufactured from 0.086-inch-thick (2.2 mm) steel.

3.2.5 Post-Nut Ceiling Clip Assemblies: The Post Nut Ceiling Clip Assembly is a 0.300-inch Head standard ceiling clip assembly, described in Section 3.2.1, with a factory- assembled post-nut (threaded eye coupling nut) attachment that accepts $1/4$ -20 threaded rod or bolts. The post nut is zinc-plated in accordance with ASTM B695 Class 5, Type 1.

3.2.6 Ballistic Point Drive Pin Ceiling Clip Assembly: The Ballistic Point Drive Pin Ceiling Clip Assembly is comprised of a Ballistic Point Drive Pin described in Section 3.1.5 and a steel clip. The clips have a 90-degree angle and are manufactured from 0.080-inch-thick (2.0 mm) steel.

3.3 Washered Pin Assemblies:

The Washered Pin Assemblies are comprised of a head drive pin described in Section 3.1.1, 3.1.2 or 3.1.3 and a premounted washer manufactured from low-carbon steel. A number of different washers are available. The washered pin assemblies are zinc-plated in accordance with ASTM B695, Class 5, Type 1, except for mechanically galvanized (MG) washered pin assemblies which are zinc plated in accordance with ASTM B695, Class 55. See Figure 4 for typical washered pin assemblies.

3.4 Substrate Material:

3.4.1 Concrete: Normalweight and sand-lightweight concrete must conform to IBC Chapter 19 or IRC Section R402.2, as applicable. The minimum concrete compressive strength at the time of fastener installation is noted in Tables 1A, 1B, 2A and 2B.

3.4.2 Steel Substrates: Structural steel must comply with the minimum requirements of ASTM A36, ASTM A572 Grade 50, or ASTM A992, and have a minimum thickness as shown in Tables 5A, 5B, 6A, 6B and 6C.

3.4.3 Steel Deck Panels: The steel deck properties and configurations must be as described in the footnotes of Tables 3A, 3B, 4A and 4B and in Figures 1A, 1B, 1C, 2A or 2B, as applicable.

3.4.4 Sill Plates: The sill plates must be nominally 2-inch-thick lumber that is naturally durable in accordance with 2015 and 2012 IBC Section 202 (2009 IBC Section 2302) or IRC Section R202; or preservative-treated in accordance with 2015 IBC Section 2303.1.9 (2012 and 2009 IBC Section 2303.1.8) or 2015, 2012 and 2009 IRC Section R317.1, as applicable.

4.0 DESIGN AND INSTALLATION

4.1 Design:

4.1.1 General: Selection of fasteners must take into consideration the applicable base material and the length of the fastener. The minimum fastener length must be determined as follows:

- For installation into concrete, concrete-filled cold-formed steel deck panels, and steel base materials, the minimum effective shank length shown in Table B must equal or exceed the sum of the thickness of the attached material and the minimum embedment depth (penetration) shown in the applicable tables in this report.
- For installation through steel base materials, the minimum effective shank length shown in Table B must equal or exceed the sum of the following: the thickness of the attached material, the thickness of the base material and the required point penetration shown in the applicable tables in this report.

4.1.2 Allowable Loads: The applicable allowable load tables for fasteners driven into different base materials may be determined by referencing Table B.

The tabulated allowable loads are applicable to the fastener in the base material and the capacity of premounted ceiling clips only. The connection capacity of the materials attached to the base materials, and of the wire or rod connected to the ceiling clip assemblies, must be determined in accordance with accepted design criteria and the applicable requirements of the IBC. The most critical applied loads, excluding seismic load effects, resulting from the load combinations in IBC Section 1605.3.1 or 1605.3.2 must not exceed these allowable loads. For fasteners which are subjected to seismic loads, see Section 4.1.6 for additional information. The stress increases and load reductions described in IBC Section 1605.3 are not allowed. The allowable tension (pull-out) and shear loads listed in this report apply only to the connection of the fastener to the base materials. Other limit states applicable to the design of a connection, such as fastener pull-through (pull-over) and lateral bearing on the attached material, which are governed by the properties of attached materials, are outside the scope of this report. Design of the connection to the attached material must comply with the applicable requirements of the IBC. When designing the connection of wood members to base materials, the bending yield strength of the power-driven fasteners can be assumed to be the same as that of a nail with the same shank diameter.

4.1.3 Combined Loading: For fasteners subjected to tension and shear loads, compliance with the following interaction equation must be verified::

$$(p/P_a) + (v/V_a) \leq 1$$

where:

p = Actual applied tension load on fastener, lbf (N).

P_a = Allowable tension load for the fastener, lbf (N).

V = Actual applied shear load on fastener, lbf (N).

V_a = Allowable shear load for the fastener, lbf (N).

4.1.4 Steel-to-steel Connections: When the fasteners listed in Tables 5A and 5B are used in connections of two steel elements in accordance with Section E5 of AISI S100-12, connection capacity must be determined in accordance with Sections 4.1.4.1 and 4.1.4.2, as applicable.

4.1.4.1 Connection Strength - Tension: To determine tensile connection strength in accordance with Section E5.2 of AISI S100-12, the fastener tension strength, pull-out strength and pull-over strength must be known. These characteristics must be determined as follows:

- **PAF Tensile Strength:** The available tension strengths must be calculated in accordance with Section E5.2.1 of AISI S100-12 using a value of 260,000 psi for F_{uh} .
- **Pull-out Strength:** See Table 5A and 5B for available pull-out strength, as applicable.
- **Pull-over Strength:** The available pull-over strengths must be calculated in accordance with Section E5.2.3 of AISI S100-12.

4.1.4.2 Connection Strength - Shear: To determine shear connection strength in accordance with Section E5.3 of AISI S100-12, the fastener shear strength, bearing and tilting strength, pull-out strength in shear, net section rupture strength and shear strength limited by edge

distance must be known. These characteristics must be determined as follows:

- **PAF Shear Strength:** The available shear strengths must be calculated in accordance with Section E5.3.1 of AISI S100-12 using a value of 260,000 psi for F_{uh} .
- **Bearing and Tilting Strength:** The available bearing and tilting strengths must be calculated in accordance with Section E5.3.2 of AISI S100-12.
- **Pull-out Strength in Shear:** The available pull-out strength in shear must be the applicable allowable shear strength from Tables 5A and 5B, as applicable, or must be calculated in accordance with Section E5.3.3 of AISI S100-12.
- **Net Section Rupture Strength and Shear Strength Limited by Edge Distance:** The net section rupture strength must be determined in accordance with Section E5.3.4 of AISI S100-12 and the shear strength limited by edge distance must be determined in accordance with Section E5.3.5 of AISI S100-12.

4.1.5 Sill Plate to Foundation Connections:

The fasteners listed in Table 7A may be used to attach wood sill plates to concrete for structural walls in Seismic Design Categories A and B. Allowable shear and tension loads for the fasteners are provided in Table 7A. Bearing area and thickness of the washers are also given in Table 7A. For shear loads, spacing of fasteners must be determined based on the lesser of the allowable shear load from Table 7A and the allowable load on the fastener/wood sill plate/concrete foundation interaction, determined in accordance with the ANSI/AWC National Design Specification (NDS) for Wood Construction, with a fastener bending yield strength, $F_{yb} = 90,000$ psi (621 MPa) and a concrete dowel bearing strength, $F_e = 7,500$ psi (52 MPa). For tension loads, spacing of fasteners must be determined based on the lesser of allowable tension load from Table 7A and pull through capacity of the wood sill plate, based on Section 3.10 of the NDS, using the washer bearing area from Table 7A. For fasteners subject to combined tension and shear loads, compliance with Section 4.1.3 must be verified.

The fasteners listed in Table 7B may be used to attach wood sill plates to concrete for interior, nonstructural walls [maximum horizontal transverse load on the wall must not exceed 5 psf (0.24 kN/m²)] in Seismic Design Categories A through F, when installed as described in Table 7B.

4.1.6 Seismic Considerations: The fasteners and ceiling clip assemblies are recognized for use when subjected to seismic loads as follows:

1. The fasteners may be used for attachment of nonstructural components listed in Section 13.1.4 of ASCE 7, which are exempt from the requirements of ASCE 7.:
2. Concrete base materials: The fasteners and assemblies installed in concrete may be used to support acoustical tile or lay-in panel suspended ceiling systems, distributed systems and distribution systems where the service load on any individual fastener does not exceed the lesser of 90 lbf (400 N) or the published allowable load in Table 1A, 1B, 2A, 2B, 3A, 3B, 4A or 4B as applicable.
3. Steel base materials: The fasteners and assemblies installed in steel may be used where the service load

on any individual fastener does not exceed the lesser of 250 lbf (1112 N) or the published allowable load shown in Table 5A, 5B, 6A, 6B or 6C, as applicable.

- 4. For interior, nonstructural walls that are not subject to sustained tension loads and are not a bracing application, the fasteners may be used to attach steel track to concrete or steel in all Seismic Design Categories. In Seismic Design Categories D, E, and F, the allowable shear load due to transverse pressure must be no more than 90 pounds (400 N) when attaching to concrete; or 250 pounds (1,112N) when attaching to steel. Substantiating calculations must be submitted addressing the fastener-to-base-material capacity and the fastener-to-attached-material capacity. Interior nonstructural walls are limited to locations where bearing walls, shear walls or braced walls are not required by the approved plans. The design load on the fastener must not exceed the allowable load established in this report for the concrete or steel base material.

4.2 Installation:

Fasteners must be installed with a powder-actuated fastening tool in accordance with the manufacturer’s recommendations. The fasteners must be installed in accordance with the manufacturer’s published installation instructions. A copy of these instructions must be available on the jobsite at all times during fastener installation.

The fastener size, minimum embedment depth or penetration, minimum spacing, and edge distances must comply with Tables 1A through 7B of this report, as applicable. For fasteners installed into concrete, the fasteners must not be driven until the concrete has reached the designated compressive strength.

The mechanically galvanized 0.300-inch Head Drive pins described in Section 3.1.1 and the mechanically galvanized washered pin assemblies described in Section 3.3 may be used in contact with preservative-treated wood in dry, interior locations only. These products may be used in contact with fire-retardant-treated wood in dry, interior locations only, in accordance with 2015 IBC Section 2304.10.5.4 (2012 and 2009 IBC Section 2304.9.4.5) and the report holder’s recommendations. Except as noted above, use of the carbon steel fasteners in contact with preservative-treated wood or in contact with fire-retardant-treated wood in exterior applications is outside the scope of this report.

5.0 CONDITIONS OF USE

The power-driven fasteners, ceiling clip assemblies, and sill plate anchorages described in this report comply with, or are suitable alternatives to what is specified in, those codes listed in Section 1.0 of this report, subject to the following conditions:

- 5.1 The fasteners must be manufactured and identified in accordance with this report.
- 5.2 The fasteners must be installed in accordance with this report and the manufacturer’s published

installation instructions. In the event of a conflict between this report and the manufacturer’s published installation instructions, the more restrictive requirements govern.

- 5.3 Calculations demonstrating that the applied loads are less than the allowable loads described in this report must be submitted to the code official for approval. The calculations must be prepared by a registered design professional where required by the statutes of the jurisdiction in which the project is to be constructed.
- 5.4 For steel-to-steel connections that meet the applicability requirements of Section E5 of AISI S100-12, calculations demonstrating that the available connection strength has been determined in accordance with Section E5 of AISI S100-12 and Section 4.1.4 of this report, and equals or exceeds the applied load, must be submitted to the code official. The calculations must be prepared by a registered design professional where required by the statutes of the jurisdiction in which the project is to be constructed.
- 5.5 For fasteners installed in concrete, the concrete must have a minimum thickness of three times the fastener penetration embedment depth, unless noted otherwise.
- 5.6 The use of the fasteners in this report is limited to installation in dry, interior environments, which include exterior walls which are protected by an exterior wall envelope.
- 5.7 The use of fasteners is limited to installation in uncracked concrete. Cracking occurs when $f_t > f_r$, due to service loads or deformations.
- 5.8 Except for the mechanically galvanized 0.300-inch Head Drive pins described in Section 3.1.1 and the mechanically galvanized washered pin assemblies described in Section 3.3, use of fasteners in contact with preservative-treated or fire-retardant-treated wood is not permitted.
- 5.9 See Section 4.1.6 for seismic considerations.
- 5.10 The products addressed in this report are manufactured under a quality control program with inspections by ICC-ES.

6.0 EVIDENCE SUBMITTED

Data in accordance with the ICC-ES Acceptance Criteria for Power-actuated Fasteners Driven into Concrete, Steel, and Masonry Elements (AC70), dated February 2016.

7.0 IDENTIFICATION

The power-driven fasteners are identified by a “P” stamped onto the head of the drive pin. Packages bear one of the company names set forth in Table A, the fastener catalog number, length and diameter, and evaluation report number (ESR-2024).

TABLE A—PRODUCT NAMES BY COMPANY

COMPANY NAME	PRODUCT NAME
DEWALT	Power-driven Fasteners (all fasteners described in this report)
Powers Fasteners	Power-driven Fasteners (all fasteners described in this report)
Max Co., Ltd.	Powerlite 0.300-inch Head Drive Pins (Section 3.1.1 of this report) Powerlite 8mm Conversion Head Drive Pins (Section 3.1.2 of this report)

TABLE B—FASTENERS (PINS AND THREADED STUDS) AND CEILING CLIP ASSEMBLY INDEX^{1,2}

PINS							
FASTENER DESCRIPTION	SHANK TYPE	SHANK DIAMETER (inch)	MAXIMUM POINT LENGTH (inch)	AVAILABLE LENGTHS (L) (inch)	MIN. EFFECTIVE SHANK LENGTH (inch)	APPLICABLE BASE MATERIAL	APPLICABLE LOAD TABLE
0.300-inch Head Drive Pins	Smooth	0.145	0.300	0.50 to 3.00	L - 0.032	Normalweight Concrete	1A, 7A
						Lt. Wt. Concrete and Concrete-filled Steel Deck	3A
	Knurled			0.50 to 0.625		Steel	5A
				Steel		5A	
8mm Head Drive Pins	Smooth	0.145	0.210	0.625 to 2.875	L - 0.032	Normalweight Concrete	1A, 7A
	Knurled			0.625 to 0.75		Steel	5A
CSI Spiral Pin (8mm head)	Spiral	0.157	0.310	0.625 to 2.875	L - 0.032	Normalweight Concrete	1B
						Lt. Wt. Concrete and Concrete-filled Steel Deck	3B
						Steel	5A, 5B
CSI Spiral Step Shank Pins (8mm Head)	Step, Spiral	0.145 / 0.125	0.180	0.50	L - 0.032	Steel	5A, 5B
Ballistic Point Drive Pins	Smooth	0.150	0.310	0.50 to 0.75	L - 0.032	Steel	5A

THREADED STUDS								
FASTENER DESCRIPTION	SHANK TYPE	SHANK DIAMETER (inch)	MAX. POINT LENGTH (inch)	LENGTH OF THREADS (inch)	AVAILABLE SHANK LENGTHS BELOW THREADS (L) (inch)	MIN. EFFECTIVE SHANK LENGTH ³ (inch)	APPLICABLE BASE MATERIAL	ALLOWABLE LOAD TABLE
³ / ₈ -inch-16 Threaded Studs	Smooth	0.205	0.310	1.25	1.04 or 1.30 (1.00 or 1.25 nominal)	L - 0.032	Normalweight Concrete	1A
							Lt. Wt. Concrete and Concrete-filled Steel Deck	3A
¹ / ₄ -inch-20 Threaded Studs	Smooth	0.145	0.180	0.50	0.83 (0.75 nominal)	L - 0.032	Normalweight Concrete	1A
				0.75	0.69, 0.83 or 1.06 (0.625, 0.75 or 1.00 nominal)		Lt. Wt. Concrete and Concrete-filled Steel Deck	3A
				1.25	1.06 (1.00 nominal)			

CEILING CLIP ASSEMBLIES						
ASSEMBLY DESCRIPTION	MAX. POINT LENGTH (inch)	AVAILABLE LENGTHS (L) (inch)	MAX. CLIP THICKNESS (inch)	MIN. EFFECTIVE SHANK LENGTH (inch)	APPLICABLE BASE MATERIAL	ALLOWABLE LOAD TABLE
0.300-inch Head Standard Ceiling Clip Assemblies	0.300	1.00 to 1.25	0.080	L - 0.112	Normalweight Concrete	2A
					Lt. Wt. Concrete and Concrete-filled Steel Deck	4A, 4B
					Steel	6A, 6B
8mm Head Standard Ceiling Clip Assemblies	0.210	1.00 to 1.25	0.080	L - 0.112	Normalweight Concrete	2A
					Lt. Wt. Concrete and Concrete-filled Steel Deck	4A
CSI Spiral Pin (8 mm Head) Ceiling Clip Assemblies	0.310	0.875 to 1.25	0.079	L - 0.111	Normalweight Concrete	2B
					Lt. Wt. Concrete and Concrete-filled Steel Deck	4B
					Steel	6C
0.300-inch Head Economy Ceiling Clip Assemblies	0.300	1.000 to 1.25	0.075	L - 0.106	Normalweight Concrete	2A
					Lt. Wt. Concrete and Concrete-filled Steel Deck	4A
LADD Ceiling Clip Assembly	0.300	1.25	0.086	L - 0.118	Normalweight Concrete	2A
					Lt. Wt. Concrete and Concrete-filled Steel Deck	4A
Ballistic Point Drive Pin Ceiling Clip Assemblies	0.300	0.875 and 1.25	0.079	L - 0.111	Steel	6A, 6B
Post Nut Ceiling Clip Assemblies	0.300	1.125 and 1.25	0.080	L - 0.112	Normalweight Concrete	2A
					Lt. Wt. Concrete and Concrete-filled Steel Deck	4A
					Steel	6A, 6B

For SI: 1 inch = 25.4 mm

¹Maximum point length is the maximum specified length from the tip of the fastener to the location where the diameter of the shank becomes constant.

²Unless otherwise noted, minimum effective shank length is the minimum specified length from the underside of the fastener head to the tip of the fastener.

³Minimum effective shank length for threaded studs is the minimum specified length from the bottom of the threads to the tip of the fastener.

TABLE 1A—ALLOWABLE LOADS FOR FASTENERS DRIVEN INTO NORMALWEIGHT CONCRETE (lbf)^{1,2,3}

FASTENER DESCRIPTION	SHANK DIAMETER (inches)	EMBEDMENT DEPTH (inches)	MINIMUM SPACING (inches)	MINIMUM EDGE DISTANCE (inches)	f'c = 2,000 psi		f'c = 3,000 psi		f'c = 4,000 psi		f'c = 5,000 psi	
					Tension	Shear	Tension	Shear	Tension	Shear	Tension	Shear
0.300-inch Head Drive Pin	0.145	5/8	3	3	25	45	60	95	45	95	25	95
		3/4			60	95	95	125	95	125	100	125
		1			100	140	130	155	155	180	200	200
		1 1/4			110	155	155	165	195	235	200	200
		1 1/2			115	175	180	175	235	290	200	200
8mm Head Drive Pin	0.145	5/8	3	3	25	45	60	95	45	95	25	95
		3/4			60	95	95	125	95	125	100	125
		1			100	140	130	155	155	180	200	200
		1 1/4			110	155	155	165	195	235	200	200
		1 1/2			115	175	180	175	235	290	200	200
3/8-inch-16 Threaded Stud ⁴	0.205	1	3	3	80	135	80	135	160	110	160	110
		1 1/4			170	220	165	220	200	320	320	
		5/8			25	45	60	95	45	95	25	95
1/4-inch-20 Threaded Stud ⁵	0.145	3/4	3	3	60	95	95	125	95	125	100	125
		1			100	140	130	155	155	180	200	200
		1 1/4			110	155	155	165	195	235	200	200

TABLE 1B—ALLOWABLE LOADS FOR FASTENERS DRIVEN INTO NORMALWEIGHT CONCRETE (lbf)^{1,2,3}

FASTENER DESCRIPTION	SHANK DIAMETER (inch)	MINIMUM EMBEDMENT (inches)	MINIMUM SPACING (inches)	MINIMUM EDGE DISTANCE (inches)	MINIMUM CONCRETE COMPRESSIVE STRENGTH, f'c					
					2,500 psi		3,000 psi		3,000 psi	
					Tension	Shear	Tension	Shear	Tension	Shear
CSI Spiral Pin (8mm Head)	0.157	3/4	4	3 1/2	120	170	130	190	130	190
		1			195	245	225	280	280	
		1 1/4			310	385	340	420	420	

For SI: 1 lbf = 4.48 N, 1 inch = 25.4 mm, 1 psi = 6.895 kPa.

Notes for Tables 1A and 1B:

- ¹Fasteners must not be driven until the concrete has reached the designated compressive strength.
- ²Concrete thickness must be a minimum of three times the embedment depth of the fastener.
- ³The fasteners listed in the table above may be used for static load conditions and for the seismic load conditions described in Section 4.1.6 of this report, as applicable. The tabulated allowable loads apply to static load conditions. For seismic load conditions, the allowable loads must be limited in accordance with Section 4.1.6, Items 2 and 4, as applicable.
- ⁴Embedment depth of 1 inch requires a minimum effective shank length of 1 inch. Embedment depth of 1 1/4 inches requires a minimum effective shank length of 1 1/4 inches.
- ⁵Embedment depth of 3/8 inch requires a minimum effective shank length of 3/4 inch. Embedment depth of 1 inch requires a minimum effective shank length of 1 inch. Embedment depth of 1 1/4 inches requires a minimum effective shank length of 1 1/4 inch.

TABLE 2A—ALLOWABLE LOADS FOR CEILING CLIP ASSEMBLIES DRIVEN INTO NORMALWEIGHT CONCRETE (lbf)^{1,2,3}

ASSEMBLY DESCRIPTION	SHANK DIAMETER (inch)	EMBEDMENT DEPTH (inches)	MINIMUM REQUIRED NOMINAL FASTENER LENGTH (inches)	MINIMUM SPACING (inches)	MINIMUM EDGE DISTANCE (inches)	f'c = 2,000 psi			f'c = 3,000 psi			f'c = 4,000 psi		
						Tension	Shear	Tension	45°	Shear	Tension	45°	Shear	Tension
0.300-inch Head Standard Ceiling Clip Assemblies	0.145	3/4	7/8	3	3	40	65	65	-	105	70	145	70	145
		7/8	1			40	65	75	145	70	145	70	145	
		1	1 1/8			40	110	75	145	100	160	100	160	
8mm Head Standard Ceiling Clip Assemblies	0.145	3/4	7/8	3	3	40	65	65	-	105	70	145	70	145
		7/8	1			40	65	75	125	70	145	70	145	
		1	1 1/8			40	110	75	125	100	160	100	160	
0.300-inch Head Economy Ceiling Clip Assemblies	0.145	3/4	7/8	3	3	40	75	40	-	75	70	145	70	145
		1	1 1/8			40	120	40	-	150	100	160	100	160
		1 1/8	1 1/4			50	50	50	-	130	135	135	135	160
LADD Ceiling Clip Assembly Post Nut Ceiling Clip Assemblies	0.145	1	1 1/8	3	3	40	-	75	-	-	100	-	100	-
		1 1/8	1 1/4			40	-	95	-	100	-	100	-	
		1 1/4	1 1/2			40	-	95	-	100	-	100	-	

TABLE 2B—ALLOWABLE LOADS FOR CEILING CLIP ASSEMBLIES DRIVEN INTO NORMALWEIGHT CONCRETE (lbf)^{1,2,3}

ASSEMBLY DESCRIPTION	SHANK DIAMETER (inch)	MINIMUM EMBEDMENT (inch)	MINIMUM REQUIRED NOMINAL FASTENER LENGTH (inches)	MINIMUM SPACING (inches)	MINIMUM EDGE DISTANCE (inches)	f'c = 3,000 psi		
						Tension	45°	Shear
CSI Spiral Pin (8mm Head) Ceiling Clip Assemblies	0.157	3/4	3/4	4	3 1/2	100	130	175
		1	1			170	215	230

For SI: 1 lbf = 4.48 N, 1 inch = 25.4 mm, 1 psi = 6.895 kPa.

Notes for Tables 2A and 2B:

- ¹Fasteners must not be driven until the concrete has reached the minimum tabulated compressive strength.
- ²Concrete thickness must be a minimum of three times the embedment depth of the fastener.
- ³The fasteners listed in the table above may be used for static load conditions and for the seismic load conditions described in Section 4.1.6 of this report, as applicable. The tabulated allowable loads apply to static load conditions. For seismic load conditions, the allowable loads must be limited in accordance with Section 4.1.6, Items 2 and 4, as applicable.

TABLE 3A—ALLOWABLE LOADS FOR FASTENERS DRIVEN INTO LIGHTWEIGHT CONCRETE AND SAND-LIGHTWEIGHT CONCRETE FILLED STEEL DECK PANELS (lbf)^{1,3}

FASTENER DESCRIPTION	SHANK DIAMETER (inches)	EMBEDMENT DEPTH (inches)	MINIMUM SPACING (inches)	f'c = 3,000 psi						f'c = 3,500 psi						
				Directly Into Concrete ²		Through 3-inch Deep Steel Deck Panel [min. base metal thickness of 0.0359 inch (F _{y,min} = 33 ksi, F _{u,min} = 45 ksi)]		Directly Into Concrete ²		Through 3-inch Deep Steel Deck Panel [min. base metal thickness of 0.0359 inch (F _{y,min} = 33 ksi, F _{u,min} = 45 ksi)]						
				Tension	Shear	Upper Flute	Lower Flute	Upper Flute	Lower Flute	Tension	Shear	Upper Flute	Lower Flute	Upper Flute	Lower Flute	
0.300-inch Head Drive Pin	0.145	3/4	3	70	70	-	-	75	75	-	-	-	-	-	-	
				200	215	175	120	290	290	220	235	190	130	-	-	315
				250	305	280	190	340	340	270	330	305	205	-	-	365
				340	375	280	235	380	380	365	405	305	255	-	-	410
1/4-inch-20 Threaded Stud	0.145	3/4	3	70	35	-	35	75	40	-	40	-	-	-	175	
				70	125	-	65	170	170	75	135	-	70	-	-	185
3/8-inch-16 Threaded Stud	0.205	1	6	70	130	-	45	165	140	-	50	-	-	-	180	
				170	265	-	85	225	225	185	285	-	90	-	-	245
Minimum Edge Distance (inches):				3	N/A	1 1/8	N/A	1 1/8	3	N/A	1 1/8	N/A	1 1/8	N/A	1 1/8	
Installation must comply with Figure:				N/A	1C	1A	1A	1A	N/A	1C	1A	1A	1C	1A	1A	

TABLE 3B—ALLOWABLE LOADS FOR FASTENERS DRIVEN INTO LIGHTWEIGHT CONCRETE AND SAND-LIGHTWEIGHT CONCRETE FILLED STEEL DECK PANELS (lbf)^{1,3}

FASTENER DESCRIPTION	SHANK DIAMETER (inch)	MINIMUM EMBEDMENT (inches)	MINIMUM SPACING (inches)	f'c = 3,000 psi						f'c = 3,000 psi					
				Directly Into Concrete ²		Through 3-inch Deep Steel Deck Panel [min. base metal thickness of 0.034 inch (F _{y,min} = 40 ksi, F _{u,min} = 55 ksi)]		Through 1 1/2-inch Deep Steel Deck Panel [min. base metal thickness of 0.034 inch (F _{y,min} = 40 ksi, F _{u,min} = 55 ksi)]		Directly Into Concrete ²		Through 3-inch Deep Steel Deck Panel [min. base metal thickness of 0.034 inch (F _{y,min} = 40 ksi, F _{u,min} = 55 ksi)]		Through 1 1/2-inch Deep Steel Deck Panel [min. base metal thickness of 0.034 inch (F _{y,min} = 40 ksi, F _{u,min} = 55 ksi)]	
				Tension	Shear	Upper Flute	Lower Flute	Upper Flute	Lower Flute	Upper Flute	Lower Flute	Tension	Shear	Upper Flute	Lower Flute
CSI Spiral Pin (8mm Head)	0.157	1	4	155	180	-	-	120	120	305	305	200	200	410	
		1 1/4		-	260	545	140	140	370	370	210	210	415		
		1 1/2		-	260	545	225	225	450	450	-	-	-		
		Minimum Edge Distance (inches):				3 1/2	-	N/A	N/A	1 1/8	1 1/8	7/8	7/8	-	
Installation must comply with Figure:				N/A	N/A	1C	1C	1A	1A	1A	1A	2	2		

For SI: 1 lbf = 4.48 N, 1 inch = 25.4 mm, 1 psi = 6.895 kPa.

N/A = Not applicable.

Notes for Tables 3A and 3B:

- ¹Fasteners must not be driven until the concrete has reached the minimum designated compressive strength.
- ²For fasteners installed directly into concrete, the concrete thickness must be a minimum of three times the embedment depth of the fastener with a minimum concrete thickness of 3 1/4 inches.
- ³The fasteners and assemblies listed in the table above may be used for static load conditions and for the seismic load conditions described in Section 4.1.6 of this report, as applicable. The tabulated allowable loads apply to static load conditions. For seismic load conditions, the allowable loads must be limited in accordance with Section 4.1.6, Items 2 and 4, as applicable.

TABLE 4A—ALLOWABLE LOADS FOR CEILING CLIP ASSEMBLIES INSTALLED IN LIGHTWEIGHT CONCRETE AND SAND-LIGHTWEIGHT CONCRETE FILLED STEEL DECK PANELS (lbf)^{1,4}

ASSEMBLY DESCRIPTION	SHANK DIAMETER (inches)	EMBEDMENT DEPTH (inches)	MINIMUM REQUIRED NOMINAL FASTENER LENGTH (inches)	MINIMUM SPACING (inches)	f'c = 3,000 psi														
					Directly into Concrete ²		Through 3-inch Deep Steel Deck Panel [min. Base Metal Thickness of 0.0359 inch (F _{y,min} = 33 ksi, F _{u,min} = 45 ksi)]				Through 1 1/2-inch Deep Steel Deck Panel [min. Base Metal Thickness of 0.0359 inch (F _{y,min} = 33 ksi, F _{u,min} = 45 ksi)]				Shear				
					Tension	45°	Tension	Upper Flute	Lower Flute	Upper Flute	Lower Flute	Upper Flute	Lower Flute	Upper Flute	Lower Flute	Upper Flute	Lower Flute		
0.300-inch Head Standard Ceiling Clip Assemblies	0.145	3/4	7/8	3	50	40	25	-	35	-	40	-	120	-	-	-	-		
		7/8	1		50	40	25	-	55	-	120	-	325	-	80	-	120	-	310
		1	1 1/8		60	40	80	135	120	180	145	350	325	-	-	-	-	-	-
8 mm Head Standard Ceiling Clip Assemblies	0.145	3/4	7/8	3	50	40	25	-	35	-	40	-	120	-	-	-	-		
		7/8	1		50	40	25	-	55	-	100	-	285	-	-	-	-		
		1	1 1/8		60	40	80	-	55	-	100	-	285	-	-	-	-		
0.300-inch Head Economy Ceiling Clip Assemblies	0.145	3/4	7/8	3	35	45	30	-	30	-	40	-	135	-	-	-	-		
		7/8	1 1/8		55	90	115	-	55	-	45	-	135	-	-	-	-		
		1	1 1/8		95	105	145	-	55	-	80	-	125	-	-	-	-		
LADD Ceiling Clip Assembly	0.152	1	1 1/8	3	60	-	-	-	135	120	-	-	-	-	-	-	-		
		1 1/8	1 1/4		60	-	-	-	135	120	-	-	-	-	-	-	-		
		Minimum Edge Distance (inches):	Installation must comply with Figure:		N/A	-	N/A	1 1/8	N/A	1 1/8	N/A	1 1/8	N/A	1 1/8	N/A	7/8	N/A	7/8	N/A

TABLE 4B—ALLOWABLE LOADS FOR CEILING CLIP ASSEMBLIES INSTALLED IN SAND-LIGHTWEIGHT CONCRETE FILLED STEEL DECK PANELS (lbf)^{1,4}

ASSEMBLY DESCRIPTION	SHANK DIAMETER (inch)	MINIMUM EMBEDMENT (inches)	MINIMUM REQUIRED NOMINAL FASTENER LENGTH (inches)	MINIMUM SPACING (inches)	f'c = 3,000 psi													
					Through 3-inch Deep Steel Deck Panel [min. Base Metal Thickness of 0.034 inch (F _{y,min} = 40 ksi, F _{u,min} = 55 ksi)]		Through 1 1/2-inch Deep Steel Deck Panel [min. Base Metal Thickness of 0.034 inch (F _{y,min} = 40 ksi, F _{u,min} = 55 ksi)]				Through 1 1/2-inch Deep Steel Deck Panel [min. Base Metal Thickness of 0.034 inch (F _{y,min} = 40 ksi, F _{u,min} = 55 ksi)]				Shear			
					Tension	45°	Tension	Upper Flute	Lower Flute	Upper Flute	Lower Flute	Upper Flute	Lower Flute	Upper Flute	Lower Flute	Upper Flute	Lower Flute	
CSI Spiral Pin (8 mm Head) Ceiling Clip Assemblies	0.157	3/4	7/8	4	-	-	-	-	-	-	-	-	-	-	-	-	-	
		7/8	1		110 ⁽³⁾	-	205 ⁽³⁾	-	340 ⁽³⁾	-	-	-	-	-	-	-	-	
		1	1		75	-	105	-	295	-	-	-	-	-	-	-	-	
Minimum Edge Distance (inches):				Installation must comply with Figure:	N/A	1	N/A	1	N/A	1	N/A	1	N/A	7/8	N/A	7/8	N/A	7/8

For SI: 1 lbf = 4.48 N, 1 inch = 25.4 mm, 1 psi = 6.895 kPa.

N/A = Not applicable.

Notes for Tables 4A and 4B:

- ¹Fasteners must not be driven until the concrete has reached the minimum designated compressive strength.
- ²For fasteners installed directly into concrete, the concrete thickness must be a minimum of three times the embedment depth of the fastener but not less than 3 1/4 inches.
- ³Fasteners must be installed in accordance with Figure 1C except the concrete topping thickness above the steel deck may be a minimum of 2 inches instead of 3 1/4 as illustrated.
- ⁴The fasteners and assemblies listed in the table above may be used for static load conditions and for the seismic load conditions described in Section 4.1.6 of this report, as applicable. The tabulated allowable loads apply to static load conditions. For seismic load conditions, the allowable loads must be limited in accordance with Section 4.1.6, Items 2 and 4, as applicable.

TABLE 5A—ALLOWABLE LOADS FOR FASTENERS DRIVEN INTO ASTM A36 STEEL (lbf)^{1,2,6}

FASTENER DESCRIPTION	SHANK DIAMETER (inches)	SHANK TYPE	STEEL THICKNESS (inch)									
			¹ / ₈		³ / ₁₆		¹ / ₄		³ / ₈		¹ / ₂	
			Tension	Shear	Tension	Shear	Tension	Shear	Tension	Shear	Tension	Shear
0.300-inch Head Drive Pin	0.145	Smooth	-	-	355 ⁽⁷⁾	565	410 ⁽⁷⁾	560	465 ⁽⁷⁾	390	390	520
0.300-inch Head Drive Pin	0.145	Knurled	170	265	-	-	-	-	-	-	-	-
8mm Head Drive Pin	0.145	Knurled	-	-	340 ⁽⁷⁾	610	445 ⁽⁷⁾	560	520 ⁽⁷⁾	605	490	575
CSI Spiral Pin (8 mm Head)	0.157	Spiral	280	540	515 ⁽⁷⁾	585	735 ⁽⁷⁾	535	615 ⁽⁷⁾	495	535 ⁽⁴⁾	565 ⁽⁴⁾
CSI Spiral Step Shank Pin (8 mm Head)	0.145 / 0.125	Spiral	45	200	240	385	250 ⁽⁷⁾	415	295 ⁽⁷⁾	385	275 ⁽⁵⁾	380 ⁽⁵⁾
Ballistic Point Pin	0.150	Smooth	-	-	-	-	310 ⁽⁷⁾	545	450 ⁽⁷⁾	525	-	-

TABLE 5B—ALLOWABLE LOADS FOR FASTENERS DRIVEN INTO ASTM A572 GRADE 50 OR ASTM A992 STEEL (lbf)^{1,3}

FASTENER DESCRIPTION	SHANK DIAMETER (inch)	SHANK TYPE	STEEL THICKNESS (inch)									
			¹ / ₈		³ / ₁₆		¹ / ₄		³ / ₈		≥ ¹ / ₂	
			Tension ⁶	Shear	Tension ⁶	Shear	Tension ⁶	Shear	Tension ⁶	Shear	Tension ⁶	Shear
CSI Spiral Pin (8 mm Head)	0.157	Spiral	325	510	550 ⁽⁷⁾	630	795 ⁽⁷⁾	580	660 ⁽⁷⁾	535	580 ⁽⁴⁾	610 ⁽⁴⁾
CSI Spiral Step Shank Pin (8 mm Head)	0.145 / 0.125	Spiral	45	200	260	415	275 ⁽⁷⁾	450	320 ⁽⁷⁾	415	300 ⁽⁵⁾	405 ⁽⁵⁾

For SI: 1 lbf = 4.48 N, 1 inch = 25.4 mm.

Notes for Table 5A and 5B:

- ¹To obtain the tabulated values, the entire pointed portion of the fastener must penetrate the steel, unless otherwise noted.
- ²The minimum spacing is 1 1/2 inches center-to-center, and minimum edge and end distances are 1/2 inch.
- ³The minimum spacing is 1 inch center-to-center, and minimum edge and end distances are 1/2 inch.
- ⁴The fasteners must be embedded a minimum of 0.50 inch into the steel. Fastener point penetration through the steel is not necessary provided the minimum embedment is achieved.
- ⁵The fasteners must be embedded a minimum of 0.41 inch into the steel. Fastener point penetration through the steel is not necessary provided the minimum embedment is achieved.
- ⁶The fasteners listed in the table above may be used for static load conditions and for the seismic load conditions described in Section 4.1.6 of this report, as applicable. The tabulated allowable loads apply to static load conditions. For seismic load conditions, the allowable loads must be limited in accordance with Section 4.1.6, Items 3 and 4, as applicable.
- ⁷For steel-to-steel connections designed in accordance with Section 4.1.4, the tabulated allowable load (ASD) may be increased by a factor of 1.25, and the design strength (LRFD) may be taken as the tabulated allowable load multiplied by a factor of 2.0 when the pointed portion protrude past the steel.

TABLE 6A—ALLOWABLE LOADS FOR CEILING CLIP ASSEMBLIES DRIVEN INTO ASTM A36 STEEL (lbf)^{1,2,3,4}

ASSEMBLY DESCRIPTION	SHANK DIAMETER (inches)	SHANK TYPE	¹ / ₈ -INCH THICK STEEL		¹ / ₄ -INCH THICK STEEL		³ / ₈ -INCH THICK STEEL	
			Tension	Shear	Tension	Shear	Tension	Shear
0.300-inch Head Standard Ceiling Clip Assemblies	0.145	Smooth	140	350	345	385	190	255
Ballistic Point Pin Ceiling Clip Assemblies	0.150	Smooth	-	-	350	510	190	240
Post Nut Ceiling Clip Assemblies	0.145	Smooth	140	-	345	-	190	-

TABLE 6B—ALLOWABLE LOADS FOR CEILING CLIP ASSEMBLIES DRIVEN INTO ASTM A572 GRADE 50 STEEL (lbf)^{1,2,3}

ASSEMBLY DESCRIPTION	SHANK DIAMETER (inches)	SHANK TYPE	¹ / ₄ -INCH THICK STEEL		³ / ₈ -INCH THICK STEEL	
			Tension	Shear	Tension	Shear
0.300-inch Head Standard Ceiling Clip Assemblies	0.145	Smooth	375	415	205	275
Ballistic Point Pin Ceiling Clip Assemblies	0.150	Smooth	380	550	205	255
Post Nut Ceiling Clip Assemblies	0.145	Smooth	375	-	205	-

For SI: 1 lbf = 4.48 N, 1 inch = 25.4 mm.

Notes for Table 6A and 6B:

- ¹To obtain the tabulated values, the entire pointed portion of the fastener must penetrate the steel.
- ²The minimum spacing is 1 inch center-to-center, and minimum edge and end distances are 1/2 inch.
- ³The fasteners listed in the table above may be used for static load conditions and for the seismic load conditions described in Section 4.1.5 of this report, as applicable. The tabulated allowable loads apply to static load conditions. For seismic load conditions, the allowable loads must be limited in accordance with Section 4.1.6, Items 3 and 4, as applicable.

TABLE 6C—ALLOWABLE LOADS FOR CEILING CLIP ASSEMBLIES INSTALLED INTO ASTM A36, ASTM A572 GRADE 50 OR ASTM A992 STEEL (lbf)^{1,2,3,4}

ASSEMBLY DESCRIPTION	SHANK DIAMETER (inch)	¹ / ₄ -INCH THICK STEEL		
		Tension	45°	Shear
CSI Spiral Pin (8 mm Head) Ceiling Clip Assemblies	0.157	350	390	420

For SI: 1 lbf = 4.48 N, 1 inch = 25.4 mm.

¹To obtain the tabulated values, the entire pointed portion of the fastener must penetrate the steel.

²The minimum spacing is ¹/₂ inches center-to-center, and minimum edge and end distances are ¹/₂ inch.

³The fasteners listed in the table above may be used for static load conditions and for the seismic load conditions described in Section 4.1.6 of this report, as applicable. The tabulated allowable loads apply to static load conditions. For seismic load conditions, the allowable loads must be limited in accordance with Section 4.1.6, Items 3 and 4, as applicable.

TABLE 7A—ALLOWABLE LOADS ON FASTENERS USED TO ATTACH WOOD SILL PLATES TO NORMALWEIGHT CONCRETE^{1,2,3}

WASHERED PIN ASSEMBLY DESCRIPTION ⁸	FASTENER SHANK LENGTH (inches)	FASTENER SHANK DIAMETER (inch)	APPLICABLE SILL PLATE MATERIAL	WASHER THICKNESS (inch)	WASHER BEARING AREA (in ²)	ALLOWABLE LOAD (lbf)	
						Tension	Shear
0.300-inch Head Drive Pin with ⁷ / ₈ " Diameter Washer	3	0.145	See Note 4	0.075	0.557	125	150
0.300-inch Head Drive Pin with 1" Diameter Washer	3	0.145	See Note 4	0.075	0.770	125	150
0.300-inch Head Drive Pin with 1" Square Washer	3	0.145	See Note 4	0.055	1.147	125	150
0.300-inch Head MG Pin with 1" Diameter Washer	3	0.145	See Note 5	0.060	0.753	125	150
0.300-inch Head MG Pin with 1" Square Washer	3	0.145	See Note 5	0.060	1.164	125	150
8mm Head Drive Pin with 1" Diameter Washer	2 ⁷ / ₈	0.145	See Note 4	0.075	0.770	125	150

For SI: 1 inch = 25.4 mm, 1 lbf = 4.48 N, 1 psi = 6.89 kPa.

¹The fasteners must not be driven until the concrete has reached a minimum compressive strength of 2,000 psi, or the minimum compressive strength specified in the applicable code, whichever is greater.

²Minimum edge distance is ¹/₄ inches.

³Wood sill plate members connected to the substrate must be investigated for compliance with the applicable code in accordance with referenced design criteria, for both lateral resistance and fastener pull-through. See Section 4.1.5 of this report.

⁴Naturally durable lumber; see Section 3.4.5 of this report.

⁵Naturally durable lumber or preservative treated lumber; see Section 3.4.5.

TABLE 7B—FASTENER SPACING REQUIREMENTS FOR WOOD SILL PLATE ANCHORAGE OF INTERIOR NONSTRUCTURAL WALLS^{1,2,3,4,5,6,7,8}

WASHERED PIN ASSEMBLY DESCRIPTION ⁸	FASTENER SHANK DIAMETER (inch) ²	FASTENER SHANK LENGTH (inches)	CONCRETE EDGE DISTANCE (inches)	MAXIMUM SPACING (feet)	MAXIMUM WALL HEIGHT (feet)
0.300-inch Head Drive Pin with ⁷ / ₈ " Diameter Washer 0.300-inch Head Drive Pin with 1" Diameter Washer 0.300-inch Head Drive Pin with 1" Square Washer 0.300-inch Head MG Pin with 1" Diameter Washer 0.300-inch Head MG Pin with 1" Square Washer	0.145	3	1 ³ / ₄	3	14
8mm Head Drive Pin with 1" Diameter Washer	0.145	2 ⁷ / ₈	1 ³ / ₄	3	14

For SI: 1 inch = 25.4 mm, 1 foot = 305 mm, 1 psi = 6.89 kPa.

¹Fasteners must not be driven until the concrete has reached a minimum concrete compressive strength of 2,500 psi.

²Interior nonstructural walls are limited to locations where bearing walls, shear walls or braced walls are not required by the approved plans.

³Fasteners must be driven into the center of the sill plate and be at least ¹/₄ inches from the concrete edge. Washer must bear on sill plate.

⁴Walls must have fasteners placed at 6 inches from ends of sill plates with maximum spacing between, as shown in this table.

⁵Walls must be laterally supported at the top and the bottom.

⁶Sill or bottom plates must comply with IBC Section 2304.1 and be of lumber with a specific gravity of 0.50 or greater. See Section 3.4.3 of this report.

⁷Minimum spacing must be 4 inches on center or must comply with Section 12.1.6 of the NDS (Section 11.1.5 for the 2012 IBC, Section 11.1.5 for the 2009) to prevent splitting of the wood. See Section 4.1.3 of this report.

⁸The fasteners listed in the table may be used to attach wood sill plates to concrete for interior, nonstructural walls [maximum horizontal transverse load on the wall must not exceed 5 psf (0.24 kN/m²)] in Seismic Design Categories A through F.

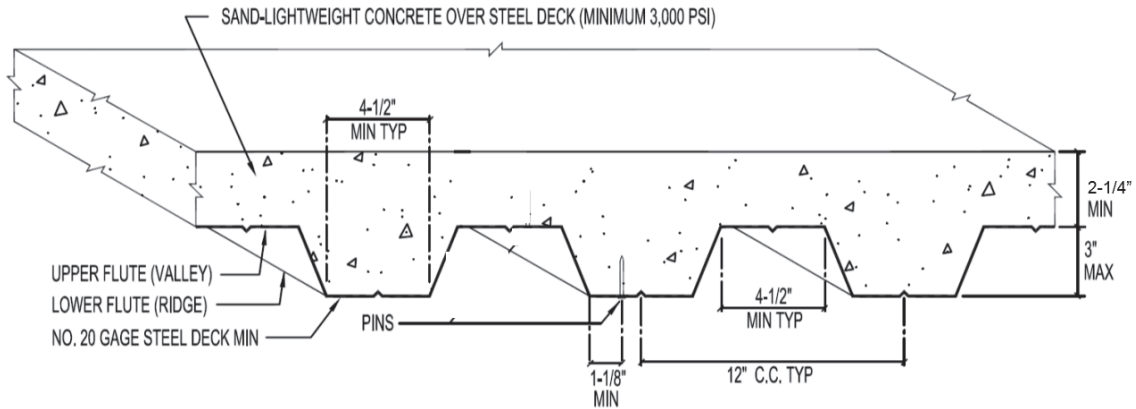

FIGURE 1A—CONFIGURATION OF CONCRETE FILLED 3-INCH DEEP STEEL DECK (LOWER FLUTE INSTALLATIONS)

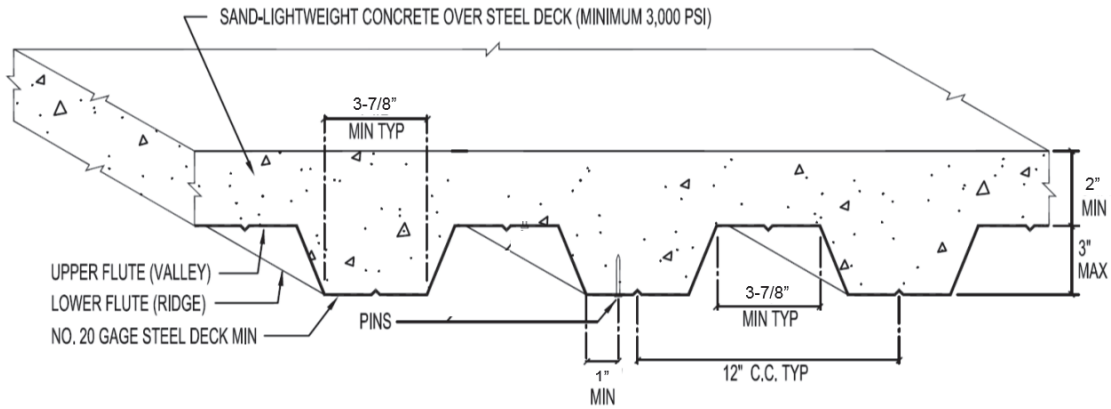

FIGURE 1B—CONFIGURATION OF CONCRETE FILLED 3-INCH DEEP STEEL DECK (LOWER FLUTE INSTALLATIONS)

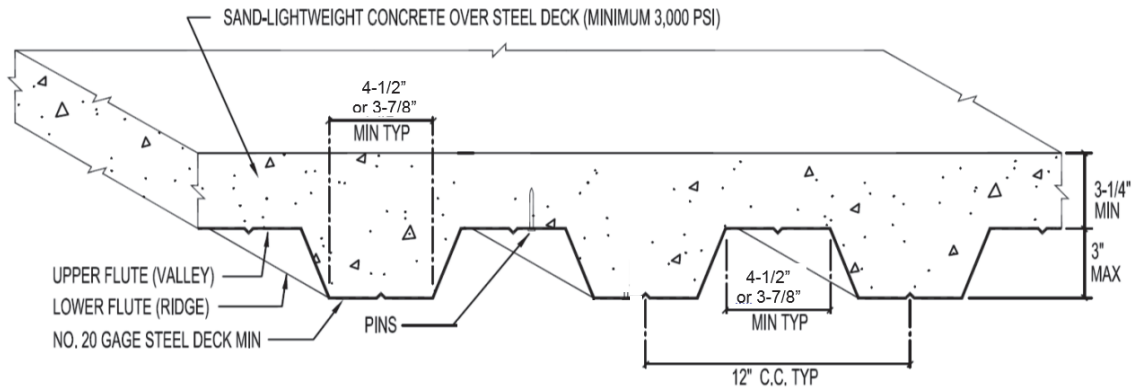

FIGURE 1C—CONFIGURATION OF CONCRETE FILLED 3-INCH DEEP STEEL DECK (UPPER FLUTE INSTALLATIONS)

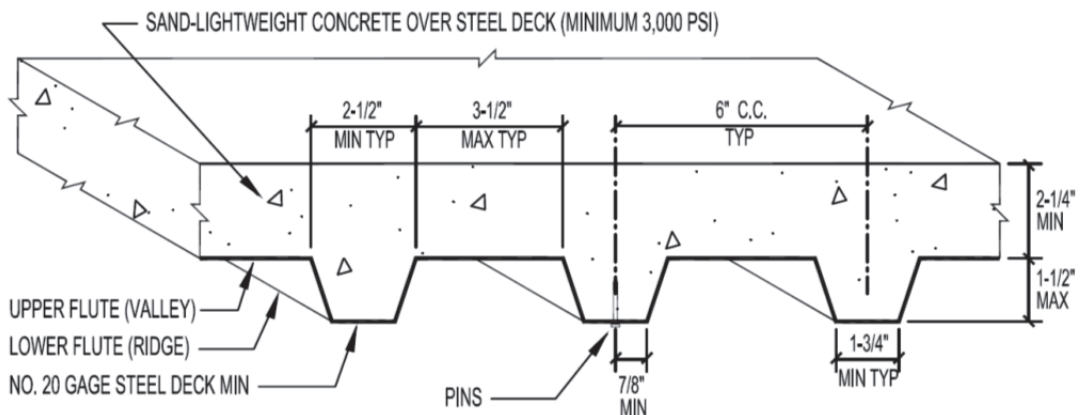

FIGURE 2—CONFIGURATION OF CONCRETE FILLED 1 1/2-INCH DEEP STEEL DECK (LOWER FLUTE INSTALLATIONS)

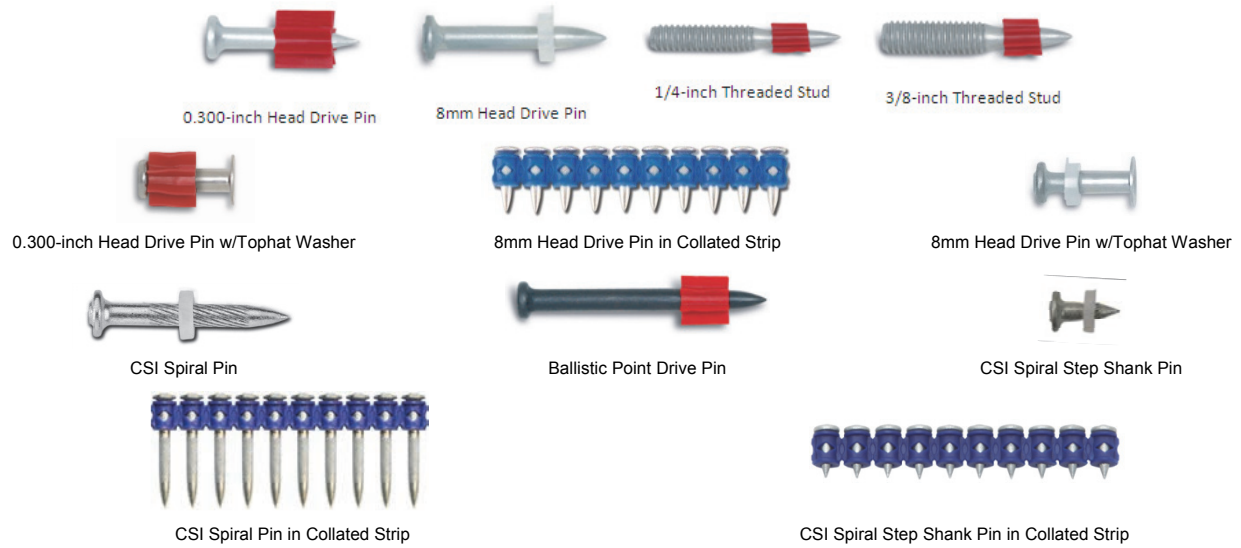

FIGURE 3—POWER-DRIVEN FASTENERS

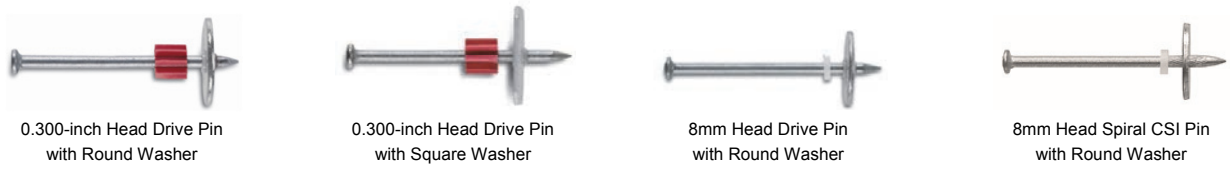

FIGURE 4—WASHERED PIN ASSEMBLIES



FIGURE 5—CEILING CLIP ASSEMBLIES

ICC-ES Evaluation Report

ESR-2024 FBC Supplement

Reissued September 2017

This report is subject to renewal September 2018.

www.icc-es.org | (800) 423-6587 | (562) 699-0543

A Subsidiary of the International Code Council®

DIVISION: 03 00 00—CONCRETE

Section: 03 15 00—Concrete Accessories

Section: 03 16 00—Concrete Anchors

DIVISION: 05 00 00—METALS

Section: 05 23 00—Metal Fastenings

DIVISION: 06 00 00—WOOD, PLASTICS AND COMPOSITES

Section: 06 05 23—Wood, Plastic and Composite Fastenings

DIVISION: 09 00 00—FINISHES

Section: 09 22 16.23—Fasteners

REPORT HOLDER:

DEWALT

701 EAST JOPPA ROAD
TOWSON, MARYLAND 21286
(800) 524-3244

www.dewalt.com
engineering@powers.com

EVALUATION SUBJECT:

POWER-DRIVEN FASTENERS, CEILING CLIP ASSEMBLIES AND SILL PLATE ANCHORAGES (DEWALT / POWERS)

1.0 REPORT PURPOSE AND SCOPE

Purpose:

The purpose of this evaluation report supplement is to indicate that the fasteners, recognized in ICC-ES master report ESR-2024, have also been evaluated for compliance with the codes noted below.

Applicable code editions:

- 2014 Florida Building Code—Building (FBC-B)
- 2014 Florida Building Code—Residential (FBC-R)

2.0 CONCLUSIONS

The fasteners, described in Sections 2.0 through 7.0 of the master evaluation report ESR-2024, comply with the *FBC-B* and *FBC-R*, provided the design and installation are in accordance with the 2012 *International Building Code*® provisions noted in the master report and the following conditions.

1. Design wind loads must be based on Section 1609 of the *FBC-B* or Section 301.2.1.1 of the *FBC-R*, as applicable.
2. Load combinations must be in accordance with Section 1605.2 or Section 1605.3 of the *FBC-B*, as applicable.

Use of the power-driven fasteners has also been found to be in compliance with the High-Velocity Hurricane Zone provisions of the *FBC-B* and the *FBC-R* under the following conditions:

- Use of the power-driven fasteners for attachment to steel as a means of attachment of wood blocking, as defined in Section 2330.1.1 of the *FBC-B*, in a roof assembly in the High-Velocity Hurricane Zone, is prohibited.
- Design wind loads must be based on Section 1620 of the *FBC-B*, as applicable.
- The fasteners have not been evaluated for use as cast-in-place anchors for compliance with the High-velocity Hurricane Zone provision and the use is outside the scope of this evaluation report.

For products falling under Florida Rule 9N-3, verification that the report holder's quality assurance program is audited by a quality assurance entity approved by the Florida Building Commission for the type of inspections being conducted is the responsibility of an approved validation entity (or the code official when the report holder does not possess an approval by the Commission).

This supplement expires concurrently with the master report, reissued September 2017.