



Most Widely Accepted and Trusted

ICC-ES Report

ICC-ES | (800) 423-6587 | (562) 699-0543 | www.icc-es.org

ESR-3744

Reissued 11/2016
This report is subject to renewal 11/2018.

DIVISION: 06 00 00—WOOD, PLASTICS AND COMPOSITES
SECTION: 06 05 23—WOOD, PLASTIC, AND COMPOSITE FASTENINGS

REPORT HOLDER:

QUICK MOUNT PV

**2700 MITCHELL DRIVE, BUILDING 2
WALNUT CREEK, CALIFORNIA 94598**

EVALUATION SUBJECT:

QUICK MOUNT PV ROOF MOUNTS



Look for the trusted marks of Conformity!

“2014 Recipient of Prestigious Western States Seismic Policy Council (WSSPC) Award in Excellence”



A Subsidiary of 

ICC-ES Evaluation Reports are not to be construed as representing aesthetics or any other attributes not specifically addressed, nor are they to be construed as an endorsement of the subject of the report or a recommendation for its use. There is no warranty by ICC Evaluation Service, LLC, express or implied, as to any finding or other matter in this report, or as to any product covered by the report.



ICC-ES Evaluation Report

ESR-3744

Reissued November 2016

Revised May 2017

This report is subject to renewal November 2018.

www.icc-es.org | (800) 423-6587 | (562) 699-0543

A Subsidiary of the International Code Council®

DIVISION: 06 00 00—WOOD, PLASTICS AND COMPOSITES
Section: 06 05 23—Wood, Plastic, and Composite Fastenings

REPORT HOLDER:

QUICK MOUNT PV
2700 MITCHELL DRIVE, BUILDING 2
WALNUT CREEK, CALIFORNIA 94598
(925) 478-8269
www.quickmountpv.com

EVALUATION SUBJECT:

QUICK MOUNT PV ROOF MOUNTS

1.0 EVALUATION SCOPE

Compliance with the following code:

- 2015, 2012 and 2009 *International Building Code*® (IBC)
- 2015, 2012 and 2009 *International Residential Code*® (IRC)
- 2013 *Abu Dhabi International Building Code* (ADIBC)[†]

[†]The ADIBC is based on the 2009 IBC. 2009 IBC code sections referenced in this report are the same sections in the ADIBC.

Properties evaluated:

- Structural
- Water penetration

2.0 USES

The Quick Mount PV Roof Mounts (QMSE, QMSE-LAG, QMSC, QMLC, QMSC-LAG and QMLC-LAG) are mounting brackets used to attach solar panel mounting systems to the wood framing of roofs with asphalt shingle or wood shake roof coverings.

3.0 DESCRIPTION

The Quick Mount PV Roof Mounts (QMSE, QMSE-LAG, QMSC, QMLC, QMSC-LAG and QMLC-LAG) have three main components: a hanger bolt or lag screw, an aluminum spacer block and a flashing plate. The hanger bolt is a ⁵/₁₆-inch-diameter-by- 6-inch-long (7.9 by 152 mm) fastener with lag-screw threads on one end and UNC threads on the opposite end. The lag screw is a ⁵/₁₆-inch-diameter-by- 5½-inch-long (7.9 by 140 mm) fastener with lag-screw threads on one end. The hanger bolts and lag screws are fabricated from stainless steel as described in the approved quality documentation. The flashing plate can

be 12 inches (305 mm) square or 18 inches (457 mm) square, formed 0.05-inch-thick (1.3 mm) aluminum conforming to ASTM B209, or 9 inches by 12 inches (229 mm by 305 mm), formed from 0.04-inch-thick (1.0 mm) aluminum conforming to ASTM B209. The 12-inch square or 9-inch-by-12-inch flashing plate is used for installation with asphalt shingles roofs and the 18-inch square flashing plate is used for installation with wood shake roofs. The aluminum spacer block measures 2.25 inches (57 mm) deep by 1.25 inches (32 mm) long. See Figure 2 for an illustration of QMSE, QMSC and QMLC Quick Mount Roof Mounts, and Figure 4 for an illustration of QMSE-LAG, QMSC-LAG and QMLC-LAG Quick Mount Roof Mounts.

4.0 DESIGN AND INSTALLATION

4.1 Design:

The tabulated allowable strengths shown in this report are based on allowable stress design (ASD) and include the load duration factor, C_D , corresponding with the applicable loads in accordance with the *ANSI/AWC National Design Specification for Wood Construction*® (NDS).

Where the roof mounts are exposed to in-service temperatures exceeding 100°F (37.8°C), uplift allowable loads shown in Table 1 must be adjusted by the temperature factor, C_t , in accordance with Section 11.3.4 of the 2015 NDS (2015 IBC and IRC) or Section 10.3.4 of the 2012 NDS (2012 IBC and IRC). When products are attached to wood framing having an in-service moisture content greater than 19 percent (16 percent for engineered wood products), or where wet service is expected, the allowable loads must be adjusted by the wet service factor, C_M , specified in Section 11.3.3 of the 2015 NDS (2015 IBC and IRC) or Section 10.3.3 of the 2012 NDS (2012 IBC and IRC). Connected wood members must be analyzed for load-carrying capacity at the connection in accordance with the NDS.

4.2 Installation:

The flashing plate must be placed underneath the shingle or shake in a weather-lap fashion. Prior to the hanger bolt or lag screw being placed through the spacer block hole, the hole must be filled with a sealant approved for roofing applications. The lag-screw end of the hanger bolt is screwed into the rafter through the spacer block and flashing plate. The sealing washer and nut are fastened through the threaded rod portion of the hanger bolt. The black gasket is then placed over the nut and through the threaded rod to seal the hole of the spacer block. Then a ⁵/₁₆-inch (7.9 mm) stainless steel nut is placed to secure

the connection of a mounting bracket, which is supplied by others, onto the UNC threaded end of the hanger bolt. If a lag screw is used, a sealing plug is placed into the spacer block cavity before the lag screw is screwed into the rafter through the spacer block and flashing plate, securing the mounting bracket, which is supplied by others. Installation of the Quick Mount Roof Mounts described in this report is limited to roofs having minimum slopes of 2:12 (18 percent) and maximum slopes of 24:12 (200 percent). The minimum specific gravity of the wood member is as noted in Tables 1 and 2.

5.0 CONDITIONS OF USE

The Quick Mount Roof Mounts described in this report comply with, or are suitable alternatives to what is specified in, the code indicated in Section 1.0 of this report, subject to the following conditions:

5.1 The Quick Mount PV Roof Mounts must be installed in accordance with this report and the manufacturer's published installation instructions. In the event of a conflict between this report and the manufacturer's published installation instructions, this report governs.

5.2 Calculations showing compliance with this report must be submitted to the code official. The calculations must be prepared by a registered design professional where required by the statutes of the jurisdiction in which the project is to be constructed.

6.0 EVIDENCE SUBMITTED

- 6.1** Load test data in accordance with ASTM D1761.
- 6.2** Rain test data in accordance with the ICC-ES Acceptance Criteria for Roof Flashing for Pipe Penetrations (AC286), dated October 2012 (editorially revised August 2013).
- 6.3** Quality documentation and installation instructions.

7.0 IDENTIFICATION

The Quick Mount PV Roof Mounts are identified with a label bearing the report holder's name (Quick Mount PV), the product name or designation, and the evaluation report number (ESR-3744).

TABLE 1—QUICK MOUNT ROOF MOUNT QMSE, QMSC and QMLC ALLOWABLE UPLIFT AND LATERAL LOADS^{1,2,3}

LOAD DIRECTION ⁴	SPECIFIC GRAVITY OF LUMBER RAFTER	ALLOWABLE LOAD (lbf)
Uplift	0.50 (Douglas fir–larch)	811
	0.36 (Western cedars)	436
Lateral	0.50 (Douglas fir–larch)	671
	0.36 (Western cedars)	634

For **SI**: 1 lbf = 4.48 N.

¹The lag screw portion of the 5/16-inch-diameter (7.9 mm) hanger bolt must be installed into the rafter with a minimum penetration of 2.875 inches (73 mm) and must satisfy edge distance specified by NDS.

²Design forces must be determined in accordance with the applicable code and must not exceed the tabulated values. No increases for load duration are permitted.

³Where the temperatures in the vicinity of the roof framing exceed 100°F (37.8°C), the tabulated uplift allowable loads must be multiplied by the temperature factor, *C_t*, set forth in Section 11.3.4 of the 2015 NDS (2015 IBC and IRC) or Section 10.3.4 of the 2012 NDS (2012 IBC and IRC). When products are attached to wood framing having an in-service moisture content greater than 19 percent (16 percent for engineered wood products), or where wet service is expected, the allowable loads must be adjusted by the wet service factor, *C_M*, specified in Section 11.3.3 of the 2015 NDS (2015 IBC and IRC) or Section 10.3.3 of the 2012 NDS (2012 IBC and IRC).

⁴Uplift load direction is perpendicular to the plane of the roof. Lateral load direction is parallel to the rafter. Lateral load perpendicular to the framing member is outside the scope of this report. See figure 1 below for a description of the load direction.

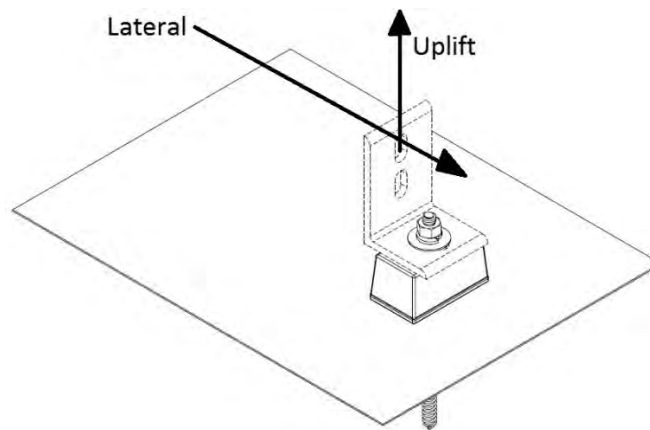

FIGURE 1

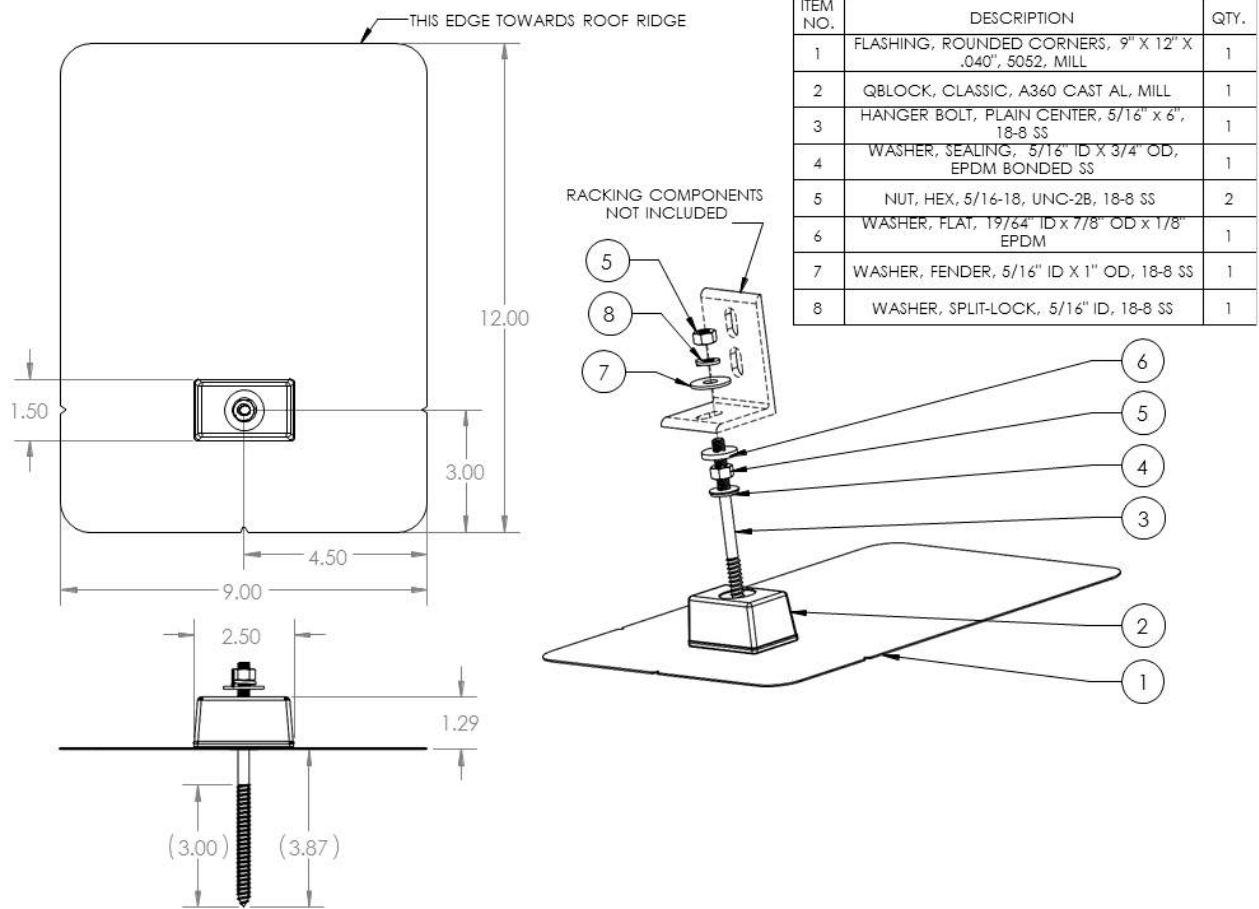

FIGURE 2—QMSE, QMSC AND QMLC Quick Mount Roof Mount (QMSE model shown)

TABLE 2—QUICK MOUNT ROOF MOUNTS QMSE-LAG, QMSC-LAG and QMLC-LAG ALLOWABLE UPLIFT AND LATERAL LOADS^{1,2,3}

LOAD DIRECTON ⁴	SPECIFIC GRAVITY OF LUMBER RAFTER	ALLOWABLE LOAD (lbf)
Uplift	0.50 (Douglas fir–larch)	732
	0.36 (Western cedars)	--
Lateral	0.50 (Douglas fir–larch)	526
	0.36 (Western cedars)	---

For SI: 1 lbf = 4.48 N.

¹The 5/16-inch-diameter (7.9 mm) lag screw must be installed into the rafter with a minimum penetration of 2.875 inches (73 mm) and must satisfy edge distance specified by NDS.

²Design forces must be determined in accordance with the applicable code and must not exceed the tabulated values. No increases for load duration are permitted.

³Where the temperatures in the vicinity of the roof framing exceed 100°F (37.8°C), the tabulated uplift allowable loads must be multiplied by the temperature factor, C_t, set forth in Section 11.3.4 of the 2015 NDS (2015 IBC and IRC) or Section 10.3.4 of the 2012 NDS (2012 IBC and IRC). When products are attached to wood framing having an in-service moisture content greater than 19 percent (16 percent for engineered wood products), or where wet service is expected, the allowable loads must be adjusted by the wet service factor, C_m, specified in Section 11.3.3 of the 2015 NDS (2015 IBC and IRC) or Section 10.3.3 of the 2012 NDS (2012 IBC and IRC).

⁴Uplift load direction is perpendicular to the plane of the roof. Lateral load direction is parallel to the rafter. Lateral load perpendicular to the framing member is outside the scope of this report. See figure 3 below for a description of the load direction.

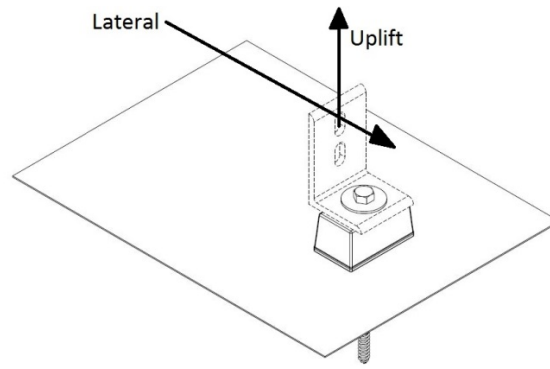
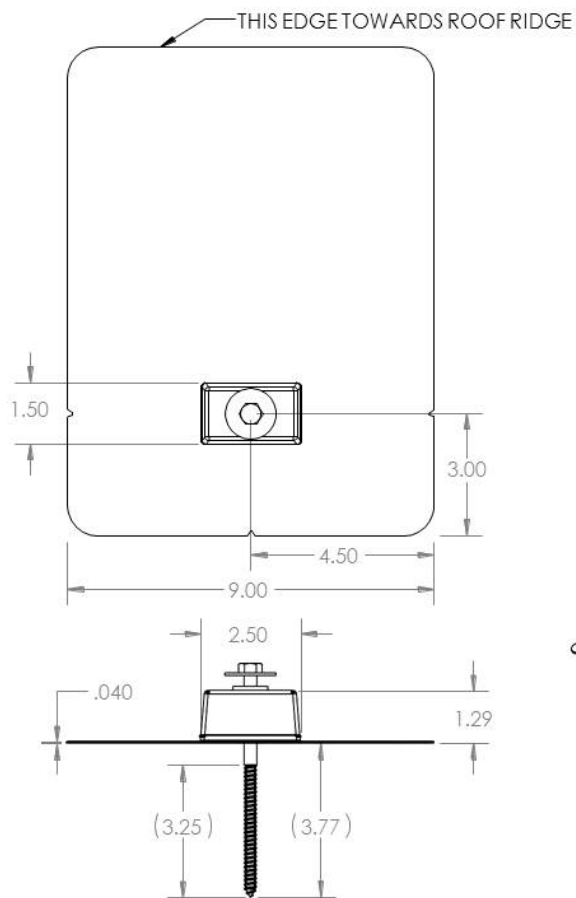

FIGURE 3



ITEM NO.	DESCRIPTION	QTY./BOX
1	FLASHING, ROUNDED CORNERS, 9" X 12" X .040", 5052, MILL	1
2	QBLOCK, CLASSIC, A360 CAST AL, MILL	1
3	PLUG, SEALING, 5/16" X 7/8", EPDM / 18-8 SS	1
4	LAG SCREW, HEX HEAD, 5/16" X 5-1/2", 18-8 SS	1
5	WASHER, FENDER, 5/16" ID X 1-1/4" OD, 18-8 SS	1

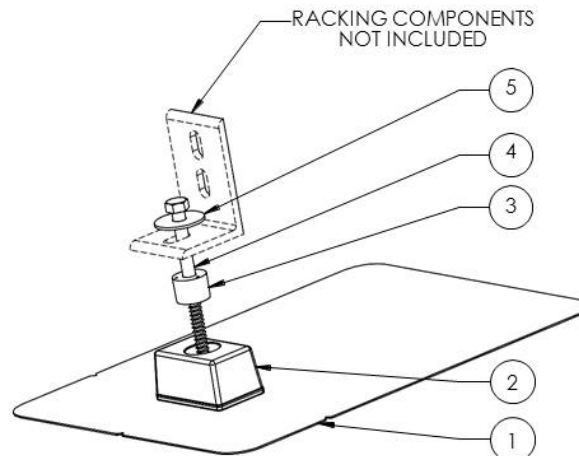

FIGURE 4—QMSE-LAG, QMLC-LAG AND QMSC-LAG Quick Mount Roof Mounts (QMSE-LAG model shown)

ICC-ES Evaluation Report

ESR-3744 CBC and CRC Supplement

Issued May 2017

This report is subject to renewal November 2018.

www.icc-es.org | (800) 423-6587 | (562) 699-0543

A Subsidiary of the International Code Council®

DIVISION: 06 00 00—WOOD, PLASTICS AND COMPOSITES
Section: 06 05 23—Wood, Plastic, and Composite Fastenings

REPORT HOLDER:

QUICK MOUNT PV
2700 MITCHELL DRIVE, BUILDING 2
WALNUT CREEK, CALIFORNIA 94598
(925) 478-8269
www.quickmountpv.com

EVALUATION SUBJECT:

QUICK MOUNT PV ROOF MOUNTS

1.0 REPORT PURPOSE AND SCOPE

Purpose:

The purpose of this evaluation report supplement is to indicate that the Quick Mount PV Roof Mounts, recognized in ICC-ES master evaluation report ESR-3744, have also been evaluated for compliance with the codes noted below.

Applicable codes:

- 2016 *California Building Code*® (CBC)
- 2016 *California Residential Code*® (CRC)

2.0 CONCLUSIONS

2.1 CBC:

The Quick Mount PV Roof Mounts, described in Sections 2.0 through 7.0 of the master evaluation report ESR-3744, comply with the CBC, provided design and installation are in accordance with the 2015 *International Building Code*® provisions noted in the master report.

The roof mounts have not been evaluated under CBC Chapter 7A for use in the exterior design and construction of new buildings located in any Fire Hazard Severity Zone within State Responsibility Areas or any Wildland–Urban Interface Fire Area.

2.2 CRC:

The Quick Mount PV Roof Mounts, described in Sections 2.0 through 7.0 of the master evaluation report ESR-3744, comply with the CRC, provided the design and installation are in accordance with the 2015 *International Residential Code*® provisions noted in the master report.

The roof mounts have not been evaluated under CRC Section R337 for use in the exterior design and construction of new buildings located in any Fire Hazard Severity Zone within State Responsibility Areas or any Wildland–Urban Interface Fire Area.

The roof mounts have not been evaluated for compliance with the *International Wildland–Urban Interface Code*®.

This supplement expires concurrently with the master report, reissued November 2016 and revised May 2017.

ICC-ES Evaluation Report

ESR-3744 FBC Supplement

Issued May 2017

This report is subject to renewal November 2018.

www.icc-es.org | (800) 423-6587 | (562) 699-0543

A Subsidiary of the International Code Council®

DIVISION: 06 00 00—WOOD, PLASTICS AND COMPOSITES
Section: 06 05 23—Wood, Plastic, and Composite Fastenings

REPORT HOLDER:

QUICK MOUNT PV
2700 MITCHELL DRIVE, BUILDING 2
WALNUT CREEK, CALIFORNIA 94598
(925) 478-8269
www.quickmountpv.com

EVALUATION SUBJECT:

QUICK MOUNT PV ROOF MOUNTS

1.0 REPORT PURPOSE AND SCOPE

Purpose:

The purpose of this evaluation report supplement is to indicate that the QuickMount PV Roof Mounts, recognized in ICC-ES master evaluation report ESR-3744, have also been evaluated for compliance with the codes noted below.

Applicable code editions:

- 2014 *Florida Building Code—Building*
- 2014 *Florida Building Code—Residential*

2.0 CONCLUSIONS

The QuickMount PV Roof Mounts, described in Sections 2.0 through 7.0 of the master evaluation report ESR-3744, comply with the 2014 *Florida Building Code—Building* and the 2014 *Florida Building Code—Residential*, provided the design and installation are in accordance with the 2012 *International Building Code*® (IBC) provisions noted in the master report.

Use of the QuickMount PV Roof Mounts for compliance with the High-Velocity Hurricane Zone provisions of the 2014 *Florida Building Code—Building* and the 2014 *Florida Building Code—Residential* has not been evaluated and is outside the scope of this supplemental report.

For products falling under Florida Rule 9N-3, verification that the report holder's quality-assurance program is audited by a quality-assurance entity approved by the Florida Building Commission for the type of inspections being conducted is the responsibility of an approved validation entity (or the code official, when the report holder does not possess an approval by the Commission).

This supplement expires concurrently with the master report, reissued November 2016 and revised May 2017.