

ICC-ES Evaluation Report

ESR-1017

Reissued May 1, 2009

This report is subject to re-examination in one year.

www.icc-es.org | (800) 423-6587 | (562) 699-0543

A Subsidiary of the International Code Council®

DIVISION: 07—THERMAL AND MOISTURE PROTECTION
Section: 07320—Roof Tiles
REPORT HOLDER:
UNITED STATES TILE COMPANY
909 RAILROAD STREET
CORONA, CALIFORNIA 92882-1906
(951) 737-0200
www.ustile.com
EVALUATION SUBJECT:
**ONE-PIECE “S,” TAPERED TWO-PIECE MISSION,
 MONARCH TWO-PIECE MISSION, FLAT SHINGLE,
 ROMANO® PAN, CLAYLITE® AND CLAYMAX® CLAY
 ROOF TILES**
1.0 EVALUATION SCOPE
Compliance with the following codes:

- 2006 *International Building Code*® (IBC)
- 2006 *International Residential Code*® (IRC)
- Other Codes (See Section 8.0)

Properties Evaluated:

- Weather resistance
- Fire classification
- Wind uplift resistance

2.0 USES

The clay roof tiles described in this report are Class A roof coverings in accordance with the exception to IBC Section 1505.2 and IRC Section R902.1.

3.0 DESCRIPTION
3.1 General:

The tiles are vitrified clay products, and are machine-formed and fired to various degrees and have a selection of burned-on colors. The various colors are obtained by controlled firing of the kilns. See Figure 1 for tile profiles and dimensions.

3.2 One-Piece “S” Tile:

The tiles are 18 inches (457 mm) long, 13 inches (330 mm) wide and $\frac{1}{2}$ inch (12.7 mm) thick, with two nail holes in the pan side and one nail hole in the cover side. The installed weight of the tiles is 8 pounds per square foot (39.1 kg/m²),

and the tiles are designed for installation with an 11-inch (279 mm) center-to-center spacing and a minimum 3-inch (76 mm) headlap.

3.3 Tapered Two-Piece Mission Tile:

The tiles are 18 inches (457 mm) long, curved to approximately one-third of a circle, and have a chord width of $8\frac{1}{2}$ inches (216 mm) at the butt end and 7 inches (178 mm) at the smaller end. The tiles have an average thickness of $\frac{1}{2}$ inch (12.7 mm) and an installed weight of 9.6 pounds per square foot (46.9 kg/m²). They are designed for installation with 11-inch (279 mm) center-to-center spacing and a minimum 3-inch (76 mm) headlap.

3.4 Monarch Two-Piece Mission Tile:

The tiles are 18 inches (457 mm) long, curved to approximately one-third of a circle, and have a chord width of $6\frac{3}{4}$ inches (171 mm) at the butt end and a chord width of $5\frac{1}{4}$ inches (133 mm) at the smaller end. The tiles have an average thickness of $\frac{1}{2}$ inch (12.7 mm). The installed weight is 10.7 pounds per square foot (52.3 kg/m²), when installation is with a 3-inch (76 mm) head lap and an $8\frac{3}{4}$ -inch (222 mm) center-to-center spacing. One nail hole is provided at the top center of each tile. The tiles conform to the Type I (high profile), Grade 3, physical requirements of ASTM C 1167.

3.5 Flat Shingle Tile:

The tiles are 18 inches (457 mm) long, $9\frac{3}{4}$ inches (248 mm) wide and $\frac{9}{16}$ inch (14.3 mm) thick. There are three ribs on the underside of the tiles that are $\frac{1}{2}$ inch (12.7 mm) wide, and one rib at the lock that is 1 inch (25.4 mm) wide. Ribs are approximately 3 inches (76 mm) apart and run the full 18-inch (457 mm) length of the tile. Each tile has two nail holes in the top. Installed weight of the tiles is $9\frac{1}{2}$ pounds per square foot (46.4 kg/m²). They are designed for installation with 9-inch (229 mm) center-to-center spacing and a minimum 3-inch (76 mm) headlap.

3.6 Romano Pan:

The tiles are 18 inches (457 mm) long, 11 inches (279 mm) wide and $\frac{9}{16}$ inch (14.3 mm) thick, with two nail holes near the top of the pan. The installed weight of the tiles is 9.9 pounds per square foot (48.3 kg/m²). They are designed for installation with Two-Piece Mission cover tiles with a 13-inch (330 mm) center-to-center spacing and a minimum 3-inch (76 mm) headlap.

3.7 Claylite Tile:

The tiles are similar in shape and size to the One-Piece “S”-shaped tiles. The finished tiles are 18 inches (457 mm)

long, 13 inches (330 mm) wide and $\frac{3}{8}$ inch (9.5 mm) thick, with two nail holes in the pan side and one nail hole in the cover side. The installed weight of the tiles is 5.9 pounds per square foot (28.8 kg/m²). They are designed for installation with an 11-inch (279 mm) center-to-center spacing and a minimum 3-inch (76 mm) headlap.

3.8 ClayMax Tile:

The tiles are 18 inches (457 mm) long, 13 inches (330 mm) wide and $\frac{13}{32}$ inch (10.3 mm) thick, with two nail holes in the top. The installed weight of the tiles is 5.8 pounds per square foot (28.3 kg/m²). They are designed for installation with an 11-inch (279 mm) center-to-center spacing and a minimum 3-inch (76 mm) headlap.

4.0 INSTALLATION

4.1 General:

Except as otherwise noted in this report, installation must be in accordance with the Concrete and Clay Roof Tile Installation Manual for Moderate Climate Regions, published by the Tile Roofing Institute and the Western States Roofing Contractors Association (hereinafter referred to as the TRI/WSRCA installation manual), and recognized in ICC-ES [ESR-2015P](#). This report and the TRI/WSRCA installation manual must be available at the jobsite at all times during installation.

4.2 Roof Slope Limitation:

The roof tiles must be installed on a minimum roof slope of 2 $\frac{1}{2}$:12 (20.83 percent).

4.3 Roofing Classification:

When installed as described in this report, the roof tiles are Class A roof coverings in accordance with the exception to IBC Section 1505.2 and IRC Section R902.1.

4.4 Wind Resistance:

4.4.1 General: When installation is on roof slopes greater than 21:12 (175 percent), the noses of all tiles must be securely fastened.

4.4.2 High Wind Applications: For applications beyond the prescriptive parameters of IBC Section 1507.3.7 and IRC Section R905.3.7, the fastening systems must be determined to withstand the aerodynamic uplift moment in accordance with the Design Considerations for High Wind Applications in Appendix B of the TRI/WSRCA installation manual.

4.5 Reroofing Applications:

The tiles may be installed over existing roofs, provided the requirements of IBC Section 1510 and IRC Section R907, as applicable, are met. The roof classification is as noted in Section 4.3.

5.0 CONDITIONS OF USE

The clay roof tiles described in this report comply with, or are suitable alternatives to what is specified in, those codes listed in Section 1.0 of this report, subject to the following conditions:

- 5.1 The roof tiles are manufactured, identified and installed in accordance with this report, the TRI/WSRCA installation manual and the applicable code. If there is a conflict between this report and the installation manual, this report governs.
- 5.2 The roof sheathing and roof framing system must be designed for the appropriate loads determined in accordance with the applicable code, subject to the approval of the code official.

- 5.3 The roof tiles are manufactured at facilities in Corona, California and Lone, California.

6.0 EVIDENCE SUBMITTED

Data in accordance with ICC-ES Acceptance Criteria for Clay and Concrete Roof Tiles (AC180), dated August 2007.

7.0 IDENTIFICATION

The letters "U.S.T." are embossed on the underside of each tile near the nail hole. Additionally, a tag must be attached to each shipping pallet that bears the report holder's name (United States Tile Company) and address, the product name, the evaluation report number (ESR-1017) and the installed weight.

8.0 OTHER CODES

8.1 Evaluation Scope:

In addition to the codes referenced in Section 1.0, the products in this report were evaluated for compliance with the requirements of the 1997 *Uniform Building Code*[®] (UBC).

8.2 Uses:

The clay roof tiles described in this report are noncombustible roof coverings in accordance with UBC Section 1504.2.

8.3 Description:

See Section 3.0.

8.4 Installation:

8.4.1 General: See Section 4.1 except for the following:

8.4.1.1 Claylite Tiles: Claylite tiles must be fastened to the sheathing with two nails per tile. As an alternative, a single nail, using the fastener hole located in the pan side $\frac{1}{4}$ inch (4.3 mm) from the head end of the tile, may be used when the following conditions are met:

- a. The roof slopes do not exceed 7:12 (58.3% slope).
- b. Solid sheathing must be not less than $\frac{7}{16}$ -inch (11.1 mm) oriented strand board or $\frac{15}{32}$ -inch (11.9 mm) wood structural panels.
- c. The structure is located in an area designated by the building official as being subject to a maximum basic wind speed of 80 miles per hour (129 km/h), Exposure C, with the roof height up to 40 feet (12 192 mm) above grade.

8.4.1.2 ClayMax Tiles: ClayMax tiles must be fastened to the sheathing with two nails per tile. As an alternative, a single nail, using the fastener hole located in the center, $\frac{1}{4}$ inch (4.3 mm) from the head end of the tile, may be used when the following conditions are met:

- a. The roof slope does not exceed 7:12 horizontal (58.3% slope).
- b. Solid sheathing is not less than $\frac{7}{16}$ -inch (11.1 mm) oriented strand board or $\frac{15}{32}$ -inch (11.9 mm), four-ply, three-layer wood structural panels.
- c. The structure is located in an area designated by the building official as being subject to a maximum basic wind speed of 80 miles per hour (129 km/h), Exposure C, with the roof height up to 40 feet (12 192 mm) above grade.

Installation details pertinent to the ClayMax tiles are as follows:

- a. Hips and ridges are provided with continuous nominally 2-by-3 nailers to support ClayMax trim tiles.
- b. Continuous nailers along the gable rakes are not required.

8.4.2 Roof Slope Limitation: See Section 4.2.

8.4.3 Roofing Classification: When installed as described in this report, the roof tiles are noncombustible roof coverings in accordance with UBC Section 1504.2.

8.4.4 Wind Resistance:

8.4.4.1 General: See Section 4.4.1.

8.4.4.2 High Wind Applications: For applications beyond the prescriptive parameters of UBC Section 1507.7, the fastening systems must be determined to withstand the aerodynamic uplift moment in accordance with the Design Considerations for High Wind Applications in Appendix B of the TRI/WSRCA installation manual.

8.4.5 Reroofing Applications: The tiles may be installed over existing roofs, provided the requirements of the Appendix to UBC Chapter 15 are met. The roof classification is as noted in Section 8.4.3.

8.5 Conditions of Use:

The clay roof tiles described in this report comply with, or are suitable alternatives to what is specified in the UBC, subject to the following conditions: See Sections 5.1 through 5.3.

8.6 Evidence Submitted:

See Section 6.0.

8.7 Identification:

See Section 7.0.

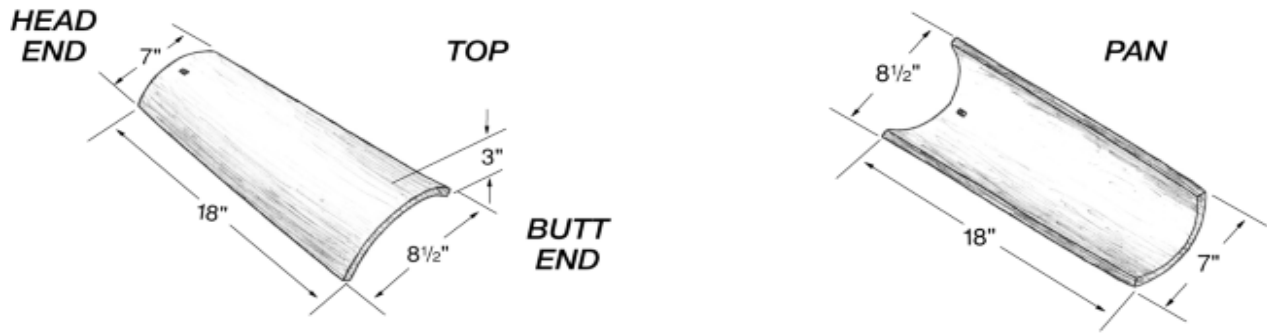

TAPERED TWO-PIECE MISSION ROOF TILE

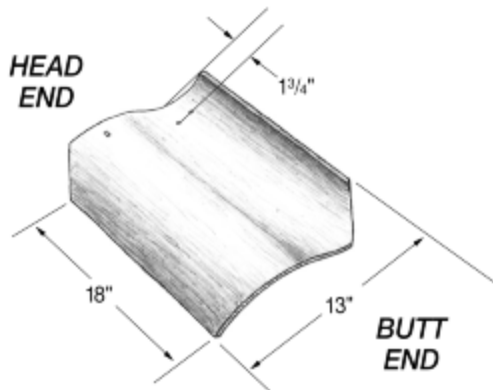

ONE-PIECE "S" AND CLAYLITE® ROOF TILE

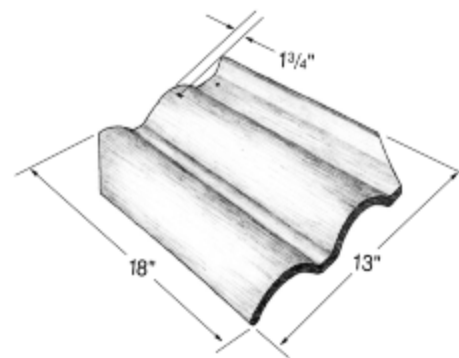

CLAYMAX® ROOF TILE

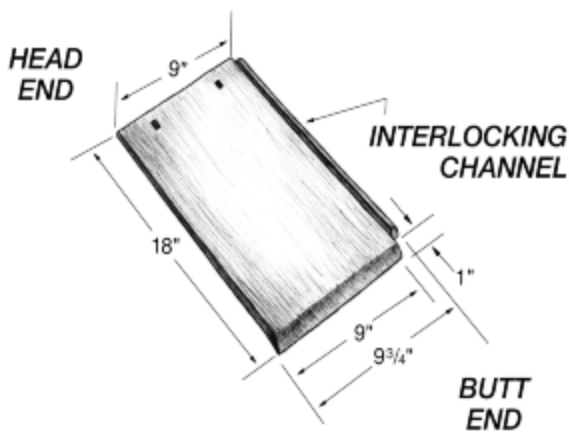

FLAT SHINGLE ROOF TILE

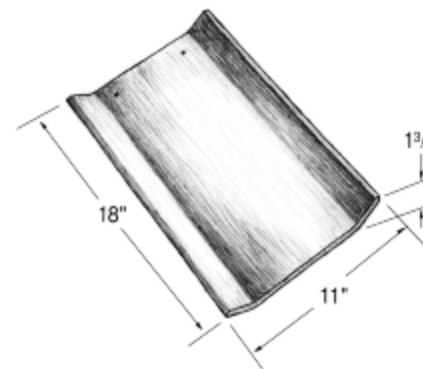

ROMANO® PAN

For SI: 1 inch = 25.4 mm

FIGURE 1—TILE PROFILES

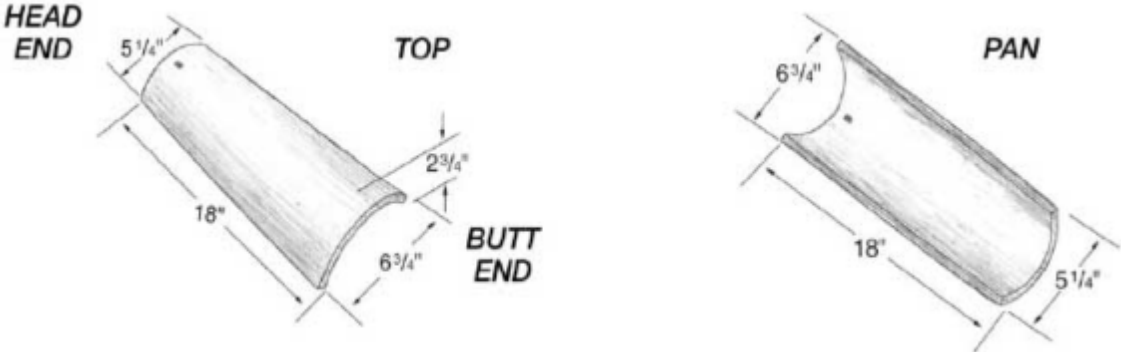

MONARCH TWO-PIECE MISSION ROOF TILE

For SI: 1 inch = 25.4 mm

FIGURE 1—TILE PROFILES (Continued)