

**ICC Evaluation Service, Inc.**  
[www.icc-es.org](http://www.icc-es.org)

**Business/Regional Office** ■ 5360 Workman Mill Road, Whittier, California 90601 ■ (562) 699-0543  
**Regional Office** ■ 900 Montclair Road, Suite A, Birmingham, Alabama 35213 ■ (205) 599-9800  
**Regional Office** ■ 4051 West Flossmoor Road, Country Club Hills, Illinois 60478 ■ (708) 799-2305

**DIVISION: 06—WOOD AND PLASTICS**  
**Section: 06500—Structural Plastics**

**REPORT HOLDER:**

**ROYAL CROWN LIMITED**  
PO BOX 360  
MILFORD, INDIANA 46542-0360  
(574) 658-9442  
[www.royalcrownltd.com](http://www.royalcrownltd.com)  
[dgargett.rci@royplas.com](mailto:dgargett.rci@royplas.com)

**EVALUATION SUBJECT:**

**DECK LOK DECKING AND STAIR TREAD**

**1.0 EVALUATION SCOPE**

**Compliance with the following codes:**

- 2003 *International Building Code*® (IBC)
- 2003 *International Residential Code*® (IRC)
- 1997 *Uniform Building Code*™ (UBC)

**Properties evaluated:**

- Structural
- Surface-burning characteristics
- Durability

**2.0 USES**

Deck Lok™ is used as flooring and stair treads for exterior balconies, porches, stairs and decks, and shall be restricted for use to exterior applications in residential buildings of Type V-N (UBC) or Type V-B (IBC and IRC) construction. Deck Lok™ is not permitted to be used in interior framing applications, such as truss components, or as joists, rafters, studs, beams, columns or posts.

Deck Lok™ has been tested and evaluated to meet the design loads of the codes listed in Section 1.0 this report, with both weathering and temperatures from -20°F (-29°C) to 125°F (52°C) taken into consideration. Any loads higher than those indicated in the applicable codes are outside the scope of this report.

**3.0 DESCRIPTION**

**3.1 General:**

Deck Lok™ is composed of 100 percent polyvinyl chloride (PVC), which is factory- formed into prefinished decking boards. Deck Lok™ decking is hollow boards 1½ inches (38 mm) deep and 5<sup>7</sup>/<sub>8</sub> inches (149 mm) wide. Decking boards are designed with an interlocking tongue-and-groove joint. The Deck Lok™ system also includes PVC C-channel trim

components, which form a nonstructural covering for the ends and edges of the decking components. See Figures 1 and 2.

Interior use of Deck Lok™ boards is beyond the scope of this report.

**3.2 Surface-burning Characteristics:**

When tested in accordance with ASTM E 84, Deck Lok™ has a flame-spread index of less than 200.

**3.3 Durability:**

When subjected to weathering, insect attack, and other decaying elements, Deck Lok™ material is equivalent in durability to preservative-treated or naturally durable lumber. Accordingly, it is permitted to be used as an alternative to preservative-treated or naturally durable lumber on decks. Additionally, it is permitted to be used in direct contact with the ground.

**4.0 DESIGN AND INSTALLATION**

Deck Lok™ decking shall be installed in accordance with the manufacturer's published installation instructions, subject to the conditions of use in this report. A copy of the manufacturer's instructions shall be available on the jobsite during installation.

**4.1 Deck Boards:**

Construction supporting Deck Lok™ decking, including but not limited to the posts, beams, joists, stringers and associated connections, is outside the scope of this report and shall be designed and constructed in accordance with the applicable code. Deck Lok™ decking components shall be limited to the maximum design loads indicated in Table 1 of this evaluation report. The allowable loads are based on use at a maximum air temperature of 125°F (52°C).

**4.2 Stair Treads:**

When Deck Lok™ decking boards are used as stair treads, the supporting construction (stringers) shall be limited to a maximum spacing of 16 inches (406 mm) on center.

**4.3 Fasteners:**

Deck Lok™ decking boards are installed perpendicular to the supporting construction, and shall be limited to a maximum spacing of 24 inches (610 mm) on center. The boards are fastened to the joist with a No. 8 by 2-inch-long (51 mm), stainless steel, pan head wood screw, with square drive, inserted through the groove; the next board is locked into that board by the interlocking tongue.

**5.0 CONDITIONS OF USE**

The Deck Lok™ decking described in this report complies with, or is a suitable alternative to what is specified in, those codes listed in Section 1.0 of this report, subject to the following conditions:

**\*Revised March 2007**

ES REPORTS™ are not to be construed as representing aesthetics or any other attributes not specifically addressed, nor are they to be construed as an endorsement of the subject of the report or a recommendation for its use. There is no warranty by ICC Evaluation Service, Inc., express or implied, as to any finding or other matter in this report, or as to any product covered by the report.



- 5.1 All stair treads shall be installed in accordance with the applicable code.
- 5.2 Construction documents consistent with this report shall be provided with permit applications. At a minimum, the following items shall be provided on the construction documents:
  - 5.2.1 On-center spacing of the supporting construction.
  - 5.2.2 Design live load imposed on Deck Lok™ decking boards and stair treads.
  - 5.2.3 Type and location of fasteners to secure the Deck Lok™ decking to the supporting construction.
  - 5.2.4 Design calculations and details for specific applications shall be furnished to the code official to verify compliance with this report and the applicable code. The calculations and details shall address the ability of the supporting construction, and all connections between the Deck Lok™ decking and the supporting construction, to resist all imposed loads, as required by the applicable code. The individual preparing the calculations and details shall

possess the necessary credentials regarding competency and qualifications as required by the applicable code and the professional registration laws of the state where the construction is to be undertaken.

- 5.3 The Deck Lok™ decking boards and stair treads are produced in Milford, Indiana, under a quality control program with inspections by RADCO (AA-650).

**6.0 EVIDENCE SUBMITTED**

- 6.1 Data in accordance with the ICC-ES Acceptance Criteria for Deck Board Span Ratings and Guardrail Systems (AC174), dated April 2002.
- 6.2 A quality control manual.
- 6.3 Installation instructions.

**7.0 IDENTIFICATION**

Each deck board and stair tread described in this report is identified by a label bearing the Royal Crown Limited name and address, the Deck Lok™ decking products name, the name of the inspection agency (RADCO) and the evaluation report number (ESR-1051).

**TABLE 1—DECK LOK™ ALLOWABLE SPANS AND DESIGN LOADS**

MEMBER	MAXIMUM SPAN BETWEEN SUPPORTS	MAXIMUM LIVE LOAD <sup>1</sup>
Deck board	24 inches	100 psf uniform load
Stair tread	16 inches	300 lbs concentrated load

For SI: 1 in. = 25.4 mm, 1 lbf/ft<sup>2</sup> = 48 Pa, 1 lb. = 0.453 kg.

Notes:

1. Design load for stair tread is a concentrated load of 300 pounds in a 2-inch-by-2-inch (51 mm by 51 mm) area.
2. The spans listed in Table 1 are valid for air temperature up to 125°F (52°C).
3. The deck board uniform load rating as given in Table 1 is for flatwise bending.
4. The spans listed in Table 1 are based on L/180 deflection.

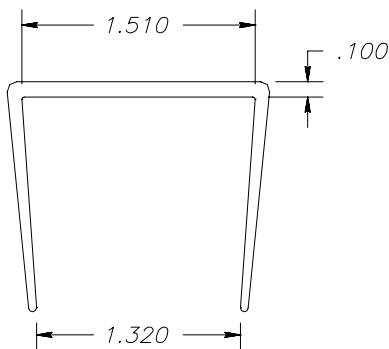

**FIGURE 1**

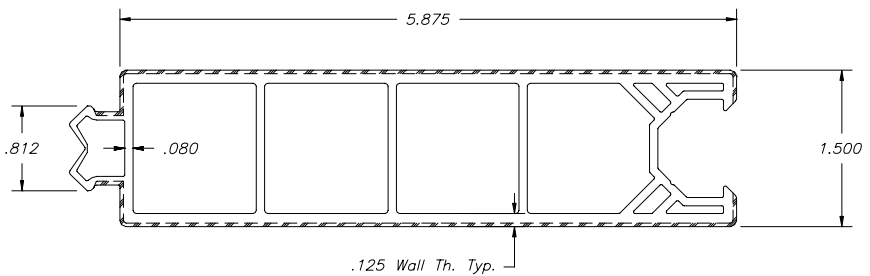

**FIGURE 2**