

ICC-ES Evaluation Report

ESR-1082

Reissued February 1, 2012

This report is subject to renewal in two years.

www.icc-es.org | (800) 423-6587 | (562) 699-0543

A Subsidiary of the International Code Council®

DIVISION: 06 00 00—WOOD, PLASTICS AND COMPOSITES
Section: 06 17 53—Shop-Fabricated Wood Trusses

REPORT HOLDER:

EAGLE METAL PRODUCTS
 POST OFFICE BOX 1267
 MABANK, TEXAS 75147-1267
www.eaglemetal.com

EVALUATION SUBJECT:

EAGLE METAL PRODUCTS EAGLE 20, EAGLE 18, EAGLE 16, EAGLE 20HS, EAGLE 18HS AND EAGLE 18 HINGE PLATE METAL TRUSS CONNECTOR PLATES

1.0 EVALUATION SCOPE
Compliance with the following codes:

- 2006 *International Building Code*® (IBC)
- 2006 *International Residential Code*® (IRC)

Property evaluated:

Structural

2.0 USES

The Eagle Metal Products Eagle 20, Eagle 18, Eagle 16, Eagle 20HS, Eagle 18HS and Eagle 18 hinge plate metal connector plates are used as joint connectors of light-framed wood roof and floor trusses.

3.0 DESCRIPTION
3.1 Eagle 20:

Eagle 20 metal truss connector plates are manufactured from minimum No. 20 gage [0.0356 inch (0.904 mm) total thickness], ASTM A 653, SS designation, Grade 40, structural steel with a G60 galvanization coating [0.0005 inch (0.013 mm) thickness each side] with base-metal thickness of 0.0346 inch (0.878 mm). Each plate has $\frac{3}{8}$ -inch-long (9.5 mm) teeth that are stamped in pairs and bent at right angles from the face of the plate. The teeth are spaced 1 inch (25.4 mm) on center along the length, and $\frac{1}{4}$ inch (6.4 mm) on center along the width, and are staggered $\frac{3}{32}$ inch (2.38 mm) off center. Each plate has eight teeth per square inch (1.24 teeth/cm²). See Figure 2 for details.

3.2 Eagle 18:

Eagle 18 metal truss connector plates are manufactured from minimum No.18 gage [0.0466 inch (1.184 mm) total thickness], ASTM A 653, SS designation, Grade 40, structural steel with a minimum G60 galvanization coating

[0.0005 inch (0.013 mm) thickness each side] with base-metal thickness of 0.0456 inch (1.158 mm). Eagle 18 metal truss connector plates are stamped identically to the Eagle 20 plates. See Figure 2 for details.

3.3 Eagle 16:

Eagle 16 metal truss connector plates are manufactured from minimum No. 16 gage [0.0575 inch (1.461 mm) total thickness], ASTM A 653, SS designation, Grade 40, structural steel with a G60 galvanization coating [0.0005 inch (0.013 mm) thickness each side] with base-metal thickness of 0.0565 inch (1.435 mm). Each plate is stamped with slightly staggered rows of slots, punched to form two teeth in each slot, with one tooth slightly longer than the other. Teeth are $\frac{7}{16}$ inch (11.1 mm) and $\frac{5}{16}$ inch (7.9 mm) long, and are formed with a slight twist that alternates (twists in the opposite direction) every third row. Slots are $\frac{5}{32}$ inch (4 mm) in width and $\frac{7}{16}$ inch (11.1 mm) in length. The slots are spaced every 1 inch (25.4 mm) along the plate length and every $\frac{1}{3}$ inch (8.5 mm) along the plate width. Every third row of slots is staggered $\frac{1}{8}$ inch (3.2 mm). Each plate has six teeth per square inch of plate area (0.93 tooth/cm²). See Figure 3 for details.

3.4 Eagle 20HS:

Eagle 20HS metal connector plates are manufactured from minimum No. 20 gage [0.0356 inch (0.904 mm) total thickness], ASTM A 653, HSLAS designation, Grade 60, structural steel with a G60 galvanization coating [0.0005 inch (0.013 mm) thickness each side] with base-metal thickness of 0.0346 inch (0.878 mm). Each plate has $\frac{3}{8}$ -inch-long (9.5 mm) teeth that are stamped in pairs and bent at right angles from the face of the plate. The teeth are spaced 1 inch (25.4 mm) on center along the length, and $\frac{1}{4}$ inch (6.4 mm) on center along the width, and are staggered $\frac{3}{32}$ inch (2.4 mm) off center. Each plate has six teeth per square inch (1.24 teeth/cm²) and every fourth row is removed. See Figure 4 for details.

3.5 Eagle 18HS:

Eagle 18HS metal connector plates are manufactured from minimum No. 18 gage [0.0466 inch (1.184 mm) total thickness], ASTM A 653, HSLAS designation, Grade 60, structural steel with a G60 galvanization coating [0.0005 inch (0.013 mm) thickness each side] with base-metal thickness of 0.0456 inch (1.158 mm). Eagle 18HS metal connector plates are stamped identically to the Eagle 20 metal connector plates. See Figure 2 for details.

3.6 Eagle 18 Hinge Plate Connector:

The Eagle 18 Hinge Plate Connector is manufactured from two metal connector plates, stamped from minimum No. 18 gage [0.0466 inch (1.184 mm) total thickness], ASTM A

653, SS designation, Grade 40, structural steel with a G60 galvanization coating [0.0005 inch (0.013 mm) thickness each side] with base-metal thickness of 0.0456 inch (1.158 mm). The two plates are overlapped by 1½ inches (38.1 mm) and factory-connected by a grommet placed in a prepunched hole in each plate. Overall, the hinge plate measures 2 inches wide by 7⅞ inches long (51 mm by 181 mm). Each metal connector plate section is composed of 36 individual teeth for a total of 72 teeth per hinge plate connector. See Figure 1 for details.

4.0 INSTALLATION

4.1 General:

All truss plates must be pressed into the wood for the full depth of their teeth by hydraulic-plate embedment presses, multiple roller presses that use partial embedment followed by full-embedment rollers, or combinations of partial embedment roller presses and hydraulic-plate presses that feed trusses into a stationary finish roller press. Trusses must be assembled within the tolerances provided by the Truss Plate Institute (TPI) Quality Criteria for Metal Plate Connected Wood Trusses, shown as Section 4 in ANSI/TPI 1-2002, National Design Standard for Metal Plate Connected Wood Truss Construction.

4.2 Allowable Design Values:

4.2.1 Eagle 20, Eagle 18, Eagle 16, Eagle 20HS and Eagle 18HS: Allowable design values for these Eagle Metal Products truss connector plates to be used in the design of metal-plate-connected wood roof and floor trusses are shown in Tables 1 and 2. Allowable design values are applicable when the connection is made with identical plates on opposite sides of the joint. This evaluation report is limited to the evaluation of connection capacity of the Eagle Metal Products truss plate connectors covered in this report. The design, manufacture, and installation of trusses employing the truss plates have not been evaluated and when applicable must comply with IBC Section 2303.4 or IRC Sections R502.11 and R802.10.

4.2.2 Eagle 18 Hinge Plate: The allowable design values of Eagle 18 Hinge Plate connectors in shear, tension and compression are shown in Table 3. Imposed forces at the joint and within the truss containing the joint must be determined using a structural model with a pin at the hinge joint location. Allowable design values are applicable when the connection is made with a 1-inch (25.4 mm), or smaller, gap between the two wood members at the connection. The design load due to combined shear and axial loads must not exceed the allowable load using the Hankinson formula as follows:

$$F_{\theta} \leq P_{\theta}$$

where:

$$F_{\theta} = \text{Imposed combined shear and axial load, lb} = (F_a^2 + F_v^2)^{0.5}$$

$$P_{\theta} = \text{Allowable combined shear and axial load, lb} = (P_a \times P_v) / ((P_a \times (\sin \theta)^2) + (P_v \times (\cos \theta)^2))$$

$$F_a = \text{Imposed axial force, lb.}$$

$$F_v = \text{Imposed shear force, lb.}$$

$$P_a = \text{Allowable axial force, lb. (in compression or tension corresponding to imposed axial force).}$$

$$P_v = \text{Allowable shear load, lb.}$$

$$\theta = \text{Angle between } F_{\theta} \text{ and the length of the plate.}$$

5.0 CONDITIONS OF USE

The Eagle Metal Products truss connector plates described in this report comply with, or are suitable alternatives to what is specified in, those codes specifically listed in Section 1.0 of this report, subject to the following conditions:

- 5.1** This evaluation report and the installation instructions, when required by the code official, must be submitted at the time of permit application. In the event of a conflict between the manufacturer's published installation instructions and this report, this report governs.
- 5.2** Each application for a building permit using these truss plate connectors must be accompanied by calculations, details and other documentation showing that the design, manufacture, and proposed installation conforms with the requirements of the applicable code. The calculations must be prepared by a registered design professional where required by the statutes of the jurisdiction in which the project is to be constructed.
- 5.3** This report establishes plate design values only. For items not covered by this report, such as truss design, fabrication, quality assurance and special inspection, refer to ANSI/TPI 1, engineering drawings and the applicable code.
- 5.4** The design values used in the design of trusses using Eagle Metal Products truss connector plates must not exceed those listed in Tables 1, 2 and 3. Load combination reductions must be in accordance with the applicable code.
- 5.5** All lumber used in the fabrication of trusses using Eagle Metal Products truss connector plates must be graded in compliance with the applicable code and must have a moisture content not to exceed 19 percent at the time of assembly. Wet service factors from ANSI/TPI 1 must be applied to the table values when the lumber moisture content exceeds 19 percent. Allowable design values shown in the tables of this report are not applicable to metal connector plates embedded in either fire-retardant-treated lumber or preservative-treated lumber.
- 5.6** Metal connector plates must be installed in pairs on opposite faces of truss members.
- 5.7** Galvanized G60 metal plate connectors subject to corrosive environments must be protected in accordance with ANSI/TPI 1.
- 5.8** The following conditions apply to Eagle 18 Hinge Plate metal connectors only:
 - 5.8.1** Allowable load values for the Eagle 18 Hinge Plates are applicable to hinge plate pairs installed on opposite faces and positioned in the 180-degree (unbent) position in the final installation of the truss.
 - 5.8.2** The allowable compression load given in Table 3 is valid for applications where sheathing is attached to the truss chord members containing the metal hinge plates, and lateral translation across the joint is inhibited by the sheathing being installed continuously across the joint as prescribed by code, or by other means acceptable to the code official. Hinge plate connectors must not be used to transfer any loads in a direction perpendicular to the plane of the truss, such as for design of load transfer at joints of unblocked diaphragms.

5.8.3 Due to the rotation provided at the joint of the Eagle 18 Hinge Plates, the truss design must be modeled with a pin at the hinge joint location. In the final installed condition, shear loads must be applied within the plane of the hinge plate, at a 90-degree angle to the long axis.

5.8.4 Design of diaphragms with trusses manufactured with the Eagle 18 Hinge Plate is outside the scope of this report.

5.8.5 Allowable design values given in Table 3 for Eagle 18 Hinge Plate connectors are applicable when the connection is made with a 1-inch (25.4 mm), or smaller, gap between the two wood members at the connection.

5.8.6 Use of the Eagle 18 Hinge Plate is limited to prefabricated trusses. Field installation is prohibited. Compliance with IBC Section 2303.4 or IRC Sections R502.11 and R802.10, as applicable, is required.

6.0 EVIDENCE SUBMITTED

6.1 Data in accordance with ANSI/TPI 1-2002.

6.2 Manufacturer's descriptive literature.

6.3 Quality documentation.

6.4 Data in accordance with the ICC-ES Acceptance Criteria for Metal Hinge Plate Connectors for Wood Trusses (AC283), dated February 2008.

7.0 IDENTIFICATION

Each Eagle Metal Products Eagle 20, Eagle 18, Eagle 16, Eagle 20HS, Eagle 18HS and Eagle 18 Hinge Plate metal plate truss connector 3 inches (76.2 mm) in width or wider, and 25 percent of plates less than 3 inches (76.2mm) in width, are identified by an embossed "EAGLE20" for the Eagle 20, "EAGLE18" for the Eagle 18, or "EAGLE16" for the Eagle 16, "EAGLE20HS" for the Eagle 20HS, "EAGLE18HS" for the Eagle 18HS and "EAGLE18" for the Eagle 18 Hinge Plate; and/or the same designations in a fast-drying permanent ink application. Additionally, boxes containing the Eagle 20, Eagle 18, Eagle 16, Eagle 20HS, Eagle 18HS and Eagle 18 Hinge Plate connector plates must bear the Eagle Metal Products name, the name of the connector (Eagle 20, Eagle 18, Eagle 16, Eagle 20HS, Eagle 18HS or Eagle 18 Hinge Plate) and the evaluation report number (ESR-1082).

TABLE 1 - LATERAL RESISTANCE ALLOWABLE DESIGN VALUES [psi/PLATE] 1, 2, 3					
LUMBER SPECIES	SG	AA	EA	AE	EE
EAGLE20, EAGLE18, & EAGLE18HS					
SOUTHERN PINE	0.55	222	185	160	168
SPRUCE-PINE-FIR	0.42	170	141	122	128
HEM-FIR	0.43	170	141	122	128
DOUGLAS-FIR-LARCH	0.50	222	185	160	168
EAGLE16					
SOUTHERN PINE	0.55	167	153	133	115
SPRUCE-PINE-FIR	0.42	117	109	105	111
HEM-FIR	0.43	123	102	90	97
DOUGLAS-FIR-LARCH	0.50	167	153	131	142
EAGLE20HS					
SOUTHERN PINE	0.55	167	139	120	126
SPRUCE-PINE-FIR	0.42	127	106	92	96
HEM-FIR	0.43	127	106	92	96
DOUGLAS-FIR-LARCH	0.50	167	139	120	126

For SI: 1 psi = 6.9 kPa.

1. Tooth holding units = psi for a single plate (lb/in²/PLATE). To achieve values, plates must be installed on opposite sides of joint.
2. AA = plate parallel to load, wood grain parallel to load
EA = plate perpendicular to load, wood grain parallel to load
AE = plate parallel to load, wood grain perpendicular to load
EE = Plate perpendicular to load, wood grain perpendicular to load
3. All truss plates are pressed into the wood for the full depth of their teeth by hydraulic-platen embedment presses, multiple roller presses that use partial embedment followed by full-embedment rollers, or combinations of partial embedment roller presses and hydraulic-platen presses that feed trusses into a stationary finish roller press.

TABLE 2 - EFFECTIVE TENSION & SHEAR ALLOWABLE DESIGN VALUES										
	EAGLE20		EAGLE18		EAGLE16		EAGLE20HS		EAGLE18HS	
	ER ²	lb/in/pr	ER ²	lb/in/pr	ER ²	lb/in/pr	ER ²	lb/in/pr	ER ²	lb/in/pr
MAX TENSION ¹ , 0°	0.60	1,050	0.61	1,395	0.60	1,725	0.66	1,683	0.57	1,917
MAX TENSION ¹ , 90°	0.47	822	0.47	1,085	0.52	1,495	0.54	1,377	0.54	1,819
MIN TENSION ¹ , 0°	0.48	836	0.48	1,104	NA	NA	0.59	1,503	0.52	1,735
MIN TENSION ¹ , 90°	0.57	989	0.57	1,305	NA	NA	0.50	1,276	0.59	1,999
SHEAR, 0°	0.62	718	0.62	946	0.53	1,029	0.54	823	0.51	1,023
SHEAR, 30°	0.67	786	0.67	1,036	0.61	1,173	0.63	956	0.60	1,207
SHEAR, 60°	0.82	956	0.82	1,260	0.73	1,411	0.73	1,124	0.75	1,488
SHEAR, 90°	0.54	632	0.54	833	0.44	845	0.41	632	0.47	928
SHEAR, 120°	0.42	491	0.42	647	0.49	948	0.46	707	0.38	774
SHEAR, 150°	0.51	592	0.51	780	0.44	852	0.39	596	0.42	849

For SI: 1 lb/in/pr = 0.18N/mm/pr

1. Max values permissible when steel is over the joint. Steel over the joint is defined as the centerline of the solid steel is within 1/16" of the joint centerline for the 90 degree orientation and the centerline of the solid steel is within 1/4" of the joint centerline for the 0 degree orientation. Min values used when steel is not over the joint.
2. ER = Efficiency Ratio

TABLE 3 - EAGLE HINGE PLATE ALLOWABLE DESIGN VALUES	
SPECIMEN LOAD TYPE	ALLOWABLE LOAD [lb]
SHEAR	696
AXIAL TENSION	970
AXIAL COMPRESSION	970

For SI: 1lb = 4.45 N.

1. Values were obtained using SPF Lumber with a SG = 0.42

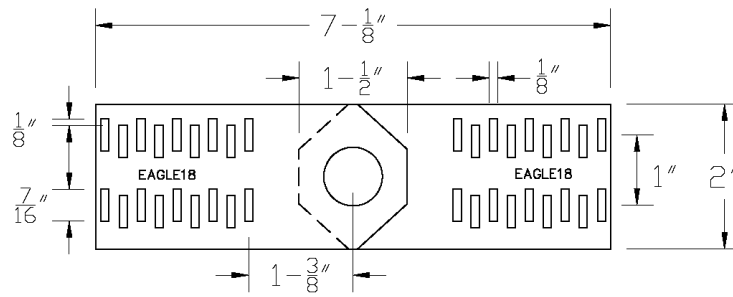

FIGURE 1 - EAGLE18 HINGE CONNECTOR PLATE

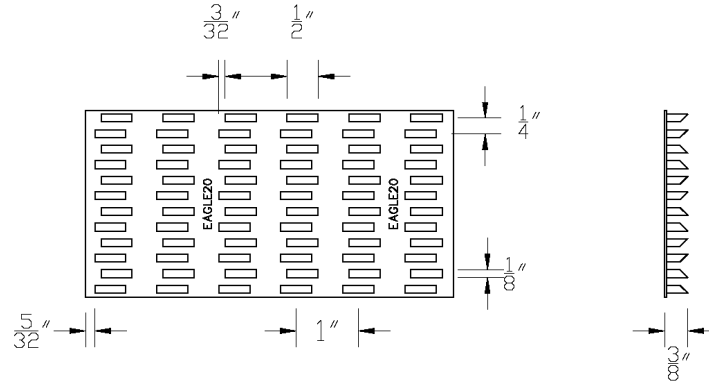

FIGURE 2 - EAGLE20, EAGLE18, EAGLE18HS CONNECTOR PLATES

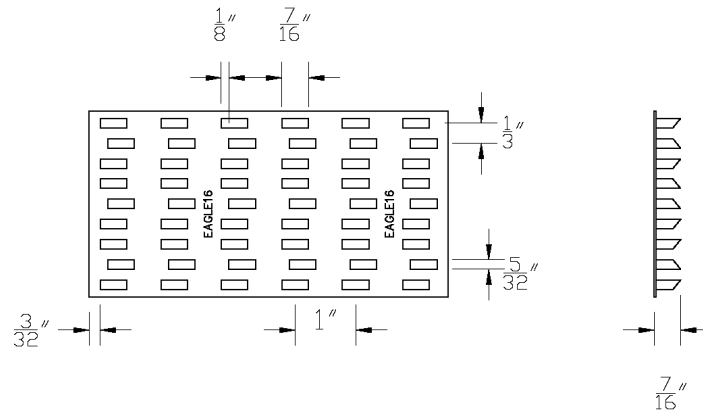

FIGURE 3 - EAGLE16 CONNECTOR PLATE

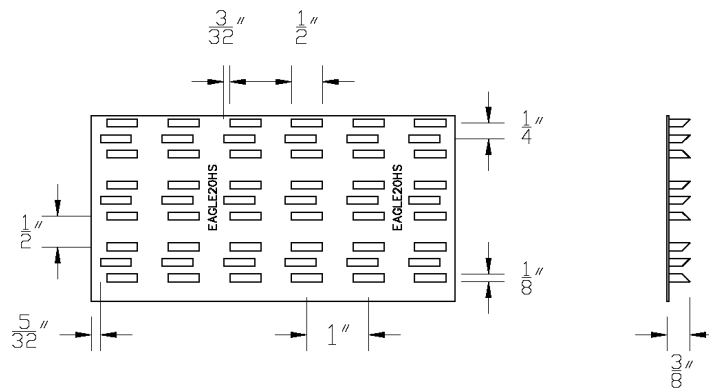

FIGURE 4 - EAGLE20HS CONNECTOR PLATE

ICC-ES Evaluation Report**ESR-1082 Supplement***Reissued February 1, 2012**This report is subject to renewal in two years.*www.icc-es.org | (800) 423-6587 | (562) 699-0543

A Subsidiary of the International Code Council®

DIVISION: 06 00 00—WOOD, PLASTICS AND COMPOSITES
Section: 06 17 53—Shop-Fabricated Wood Trusses**REPORT HOLDER:****EAGLE METAL PRODUCTS**
POST OFFICE BOX 1267
MABANK, TEXAS 75147-1267
www.eaglemetal.com**EVALUATION SUBJECT:****EAGLE METAL PRODUCTS EAGLE 20, EAGLE 18, EAGLE 20HS AND EAGLE 18HS METAL TRUSS CONNECTOR PLATES****1.0 EVALUATION SCOPE****Compliance with the following codes:**

- 2007 *Florida Building Code—Building*
- 2007 *Florida Building Code—Residential*

Property evaluated:

Structural

2.0 PURPOSE OF THIS SUPPLEMENT

This supplement is issued to indicate that the Eagle Metal Products Metal Truss Connector Plates (Eagle 20, Eagle 18, Eagle 20HS and Eagle 18HS) described in Sections 2.0 through 7.0 of the master report comply with the 2007 *Florida Building Code—Building* and the 2007 *Florida Building Code—Residential*, when designed and installed in accordance with the master evaluation report.

For products falling under Florida Rule 9B-72, verification that the report holder's quality assurance program is audited by a quality assurance entity approved by the Florida Building Commission for the type of inspections being conducted is the responsibility of an approved validation entity (or the code official when the report holder does not possess an approval by the Commission).

This supplement expires concurrently with the master report reissued February 1, 2012.