

ICC Evaluation Service, Inc.
www.icc-es.org

Business/Regional Office ■ 5360 Workman Mill Road, Whittier, California 90601 ■ (562) 699-0543
Regional Office ■ 900 Montclair Road, Suite A, Birmingham, Alabama 35213 ■ (205) 599-9800
Regional Office ■ 4051 West Flossmoor Road, Country Club Hills, Illinois 60478 ■ (708) 799-2305

DIVISION: 06—WOOD AND PLASTIC
Section: 06500—Structural Plastic
Section: 06610—Plastic Railing and Guards

REPORT HOLDER:

COMPOSATRON MANUFACTURING INCORPORATED
25 IRONSIDE CRESCENT
TORONTO, ONTARIO M1X 1G5
CANADA
(416) 335-6500
www.composatron.com
jpratt@composatron.com

EVALUATION SUBJECT:

PREMIER COMPOSITE DECKING AND RAILING SYSTEMS

ADDITIONAL LISTEE:

THE DOW CHEMICAL COMPANY
200 LARKIN CENTER
MIDLAND, MICHIGAN 48674
jesurma@dow.com
PRODUCT NAME: DOW SYMMATRIX SCENIC SERIES
DECKING

1.0 EVALUATION SCOPE

Compliance with the following codes:

- 2003 *International Building Code*® (IBC)
- 2003 *International Residential Code*® (IRC)
- 1997 *Uniform Building Code*™ (UBC)

Properties evaluated:

- Structural
- Durability
- Surface-burning characteristics

2.0 USES

The Premier Composite Decking System described in this report is limited to exterior use as deck boards for balconies, porches, and decks. The Premier Composite Railing System described in this report is limited to exterior use as guards for balconies, porches, and decks. The products described in this report are used in Group R Occupancy (residential) buildings of Type V-B (IBC) or Type V-N (UBC) construction and buildings constructed in accordance with the IRC. The Premier Composite Railing System, Colonial Guard, is for use in One- and Two-Family Dwellings only.

3.0 DESCRIPTION

3.1 General:

The Premier Composite Decking and Railing Systems are made from a composite material that consists of wood fibers and a thermoplastic polymer plastic. The deck boards and railing are manufactured by an extrusion process in accordance with the approved quality control manual, to produce comparable lumber-sized members and railing components.

3.2 Deck Board:

3.2.1 General: The Premier Composite Decking board is a 38 percent polyethylene, 50 percent wood fiber and 12 percent additive material, manufactured with dimensions of 1.0 inch by 5.44 inches (25.4 by 138 mm) and 0.9 inch by 3.56 inches (22.9 by 90 mm). Figure 1 provides dimensioned cross-sectional profiles of the board.

3.2.2 Durability: The material used to manufacture the Premier Composite Decking boards described in this report is equivalent in durability to code-complying preservative-treated or naturally durable lumber when used in locations described in Section 2.0. Premier Composite Decking products have been evaluated for structural performance when exposed to temperatures ranging from -20°F (-29°C) to 125°F (52°C).

3.2.3 Surface-burning Characteristics: When tested in accordance with ASTM E 84, the Premier Composite Decking boards described in this report have a flame-spread index of no greater than 200.

3.3 Guards:

3.3.1 General: Premier Composite Railing is a 49 percent wood fiber and 51 percent polyvinyl chloride (PVC) guard system consisting of post sleeves and caps, optional Premier steel surface mount bracket, top and bottom rails, a top-rail retainer, balusters, and a bottom-rail support block. The post sleeves are placed over a 17-inch-long (432 mm) Premier steel surface mount bracket holding a nominally 4-inch-by-4-inch (102 by 102 mm), preservative-treated, spruce-pine-fir, construction-grade wood member.

3.3.2 Premier Composite Railing System:

3.3.2.1 Colonial Profile: The guard's top rail is manufactured in two Colonial- type cross sections with nominal widths of 2½ inches (64 mm) and 3½ inches (89 mm). Both top rail sections must be installed over a "retainer" top rail (see Figure 3). The bottom rail has nominal cross-sectional dimensions of 1⅝ inches by 2⅛ inches (41 by 54 mm). The balusters are 1¼-inch-by-1¼-inch (31 by 31 mm) square hollow cross sections with internal webs. The guard system is available in standard 6- and 8-foot (1830 and 2440

*Revised January 2007

ES REPORTS™ are not to be construed as representing aesthetics or any other attributes not specifically addressed, nor are they to be construed as an endorsement of the subject of the report or a recommendation for its use. There is no warranty by ICC Evaluation Service, Inc., express or implied, as to any finding or other matter in this report, or as to any product covered by the report.



mm) lengths with heights of 36 inches and 42 inches. The post sleeve is comprised of a wood plastic composite (WPC) hollow sleeve measuring 4¹/₄ inches by 4¹/₄ inches (108 mm by 108 mm) on the outside, which slides over a 17-inch-long (432 mm) steel surface mount bracket holding a nominally 4-inch-by-4-inch (102 by 102 mm), preservative-treated, spruce-pine-fir, construction-grade wood member. Figure 2 provides dimensioned cross-sectional profiles of the rails, baluster and post sleeve.

3.3.2.2 Victorian Profile: The guard's top rail is manufactured in a Victorian- type cross section with a 3¹/₂-inch (90 mm) nominal width. The top rail section is designed to be installed over a "retainer" top rail (see Figure 5). The bottom rail has nominal cross-sectional dimensions of 1⁵/₈ inches by 2¹/₈ inches (41 by 54 mm). The balusters are 1¹/₄-inch-by-1¹/₄-inch (31 by 31 mm) square hollow cross sections with internal webs. The guard system is available in a standard 6-foot (1830 mm) length with heights of 36 inches (914 mm) and 42 inches (1067 mm). The post sleeve is comprised of a WPC hollow sleeve measuring 4¹/₄ inches by 4¹/₄ inches (108 mm by 108 mm) on the outside, which slides over a 17-inch-long (432 mm) steel surface mount bracket holding a nominally 4-inch-by-4-inch (102 by 102 mm), preservative- treated, spruce-pine-fir, construction-grade wood member. Figure 4 provides dimensioned cross-sectional profiles of the rails, baluster and post sleeve.

3.3.3 Durability: The material used to manufacture Premier Composite Railing is equivalent in durability to code-complying, preservative-treated or naturally durable lumber when used in locations described in Section 2.0.

3.3.4 Surface-burning Characteristics: When tested in accordance with ASTM E 84, Premier Composite Railing has a flame-spread index of no greater than 200.

4.0 DESIGN AND INSTALLATION

4.1 General:

Installation of the Premier Composite Decking and Railing Systems described in this report must comply with this report and the manufacturer's published installation instructions. The manufacturer's published installation instructions must be available at the jobsite at all times during installation. When the manufacturer's published installation instructions differ from this report, this report governs.

4.2 Deck Boards:

4.2.1 Structural: Premier Composite Decking, when used as a deck board, has an allowable live load capacity when installed perpendicular to the supporting construction, and at a maximum center-to-center spacing of the supporting construction, as prescribed in Table 1.

4.2.2 Fasteners: The boards must be attached at each wood joist using two No. 9 by 2¹/₂-inch-long (38 mm) corrosion-resistant wood screws. The maximum allowable fastener head pull-through load is 303 lbf (1364 N) per fastener. Fasteners located within 1/4 inch (6 mm) of the ends of each board must be predrilled. A minimum of 1/8 inch (3 mm) of space must be provided between installed deck boards.

4.3 Guards:

4.3.1 Structural: The Premier Composite Railing System resists the loads specified in Chapter 16 of the IBC and UBC, and Chapter 3 of the IRC, when installed at a maximum distance between posts as prescribed in Table 2. When the railing is supported on one or both ends by the supporting construction, the maximum distance must be measured from the inside face of the post to edge-of-structure or edge-of-structure to edge-of-structure, respectively.

4.3.2 Installation:

4.3.2.1 Premier Composite Railing System Post Sleeves:

The Premier Composite Railing System post sleeve slides over the Premier steel surface mount bracket holding a dry, preservative-treated, nominally 4-by-4, spruce-pine-fir, construction-grade wood post with a minimum specific gravity of 0.42. The post must not be notched or cut in any way other than trimming for length.

4.3.2.2 Premier Composite Railing System:

The retaining rail and the bottom rail must be attached through the composite post sleeve to the steel surface mount bracket or wood post insert utilizing two No.14 by 2-inch-long (51 mm) stainless steel pan head screws at each end of each rail. There are two imbedded threaded inserts at each end of the bottom rail and the top retaining rail. Two 1/4"-20 by 1/2"-inch-long (6.4 mm by 12.7 mm), stainless steel pan head bolts are utilized to attach the brackets, manufactured from stainless steel and 1¹/₂ inches (38 mm) long, to each end of the bottom rail and the top retaining rail. The top rail is installed over the retaining rail and attached with three No. 8 by 1-inch-long (25.4 mm) stainless steel screws equally spaced along the rail length.

Balusters are installed with a single No. 8 by 2-inch-long (51 mm) stainless steel wood screw through the retainer rail and a single No. 8 by 3-inch-long (76 mm) stainless steel wood screw installed through the bottom rail. All fasteners are provided by Composatron Manufacturing Incorporated. Figures 3 and 5 provide cross-sectional profiles of the rails and baluster showing how they connect together.

Each post sleeve is mounted to the supporting framing by means of the steel surface mount bracket in accordance with the manufacturer's installation instructions, or by boxing in the nominally 4-inch-by-4-inch (102 mm by 102 mm) PT SPF post so there is support on all four sides.

The Premier Composite Top Railing, when installed as specified in this report and the manufacturer's published installation instructions, is permitted to be constructed with a maximum rail length as noted in Table 2 when supported by construction capable of withstanding the loads described in the applicable building codes. See Figures 6 through 9.

5.0 CONDITIONS OF USE

The Premier Composite Decking and Railing Systems described in this report comply with, or are suitable alternatives to what is specified in, those codes listed in Section 1.0 of this report, subject to the following conditions:

- 5.1** The Premier Composite Decking described in this report is limited to exterior use as deck boards for balconies, porches, and decks; and the Premier Composite Railing System described in this report is limited to guards for balconies, porches, decks and similar appendages of Group R Occupancy buildings of Type V-B (IBC) or Type V-N (UBC) construction and structures constructed in accordance with the IRC. The Premier System has not been evaluated for use as a handrail or as a guard for stairs.
- 5.2** Installation must comply with this report, the manufacturer's published installation instructions, and the IBC, IRC and UBC. Only those fasteners and fastener configurations described in this report have been evaluated for the installation of the Premier Composite Decking and Railing Systems.
- 5.3** The use of the Premier Composite Decking as a component of a fire-resistance-rated assembly is outside the scope of this report.
- 5.4** Adjustment factors outlined in the NDS, the IBC, the IRC and the UBC do not apply to the allowable capacity

and maximum spans for Premier Composite Decking and Railing Systems.

- 5.5** The Premier Composite Decking and Railing Systems must be directly fastened to supporting construction. Where required by the code official, engineering calculations and construction documents consistent with this report must be submitted for approval. The calculations must verify that the supporting construction complies with IRC requirements and is adequate to resist the loads imparted upon it by the products and systems discussed in this report. The documents must contain details of the attachment to the supporting structure consistent with the requirements of this report. The documents must be prepared by a registered design professional where required by the statutes of the jurisdiction in which the project is to be constructed.
- 5.6** The compatibility of fasteners, metal post mount components and other metal hardware with the supporting construction, including chemically treated wood, is outside the scope of this report.
- 5.7** The use of the post sleeve installed over inserts other than those described in this report (see Sections 3.3.1 and 4.3.2.1) is outside the scope of this report.
- 5.8** The Premier Composite Railing System, Colonial Guard, is "For Use in One- and Two-Family Dwellings Only."

- 5.9** The Premier Composite Decking and Railing Systems are produced by Composatron Incorporated at their facility located in Toronto, Ontario; under a quality control program with inspections by Intertek Testing Services (AA-688).

6.0 EVIDENCE SUBMITTED

Data in accordance with the ICC-ES Acceptance Criteria for Deck Board Span Ratings and Guardrail Systems (Guards and Handrails) (AC174), dated April 2002 (editorially revised July 2004; corrected December 2004).

7.0 IDENTIFICATION

- 7.1 Deck Board:** Each piece of product must be identified by a stamp or nonremovable label noting the names of the product and the manufacturer ("Composatron Manufacturing Incorporated"); the evaluation report number (ESR-1481); and the name of the inspection agency (Intertek Testing Services).
- 7.2 Guards:** Each railing component described in this report must be identified by a label on each individual piece or article of packaging bearing the name of the product and the manufacturer's name ("Composatron Manufacturing Incorporated"); the evaluation report number (ESR-1481); and the name of the inspection agency (Intertek Testing Services). The Colonial Guard system label must also include the phrase "For Use in One- and Two-Family Dwellings Only."

TABLE 1—DECK BOARD SPAN RATIOS

DECK BOARD	MAXIMUM SPAN (in) ¹	ALLOWABLE CAPACITY (lbf/ft ²) ²
Premier (at 90° to supporting joist)	16	100

For SI: 1 inch = 25.4 mm; 1 lbf/ft² = 47.9 Pa.

¹Maximum span is measured center-to-center of the supporting construction.

²Maximum allowable capacity is adjusted for durability. No further increases are permitted.

TABLE 2—MAXIMUM GUARDRAIL SYSTEM SPANS¹

PRODUCT NAME/COMPONENT	APPLICABLE BUILDING CODE ²			MAXIMUM SPAN ^{3,4} (ft-in)
	IBC	IRC	UBC	
Colonial 2½ inch Guard ⁵	Yes	Yes	—	6 - 0
Colonial 3½ inch Guard ⁵	Yes	Yes	—	8 - 0
Victorian 3½ inch Guard	Yes	Yes	Yes	6 - 0

For SI: 1 inch = 25.4 mm; 1 ft = 305 mm.

¹The ability of the supporting construction to resist the reactionary loads must be justified to the satisfaction of the code official when required.

²Indicates compliance with the respective building codes.

³Maximum span is measured from inside edge of post to inside edge of post or inside of post to edge of structure, or edge of structure to edge of structure.

⁴Maximum allowable span has been adjusted for durability. No further increases are permitted.

⁵For use in One- and Two-Family Dwellings only.

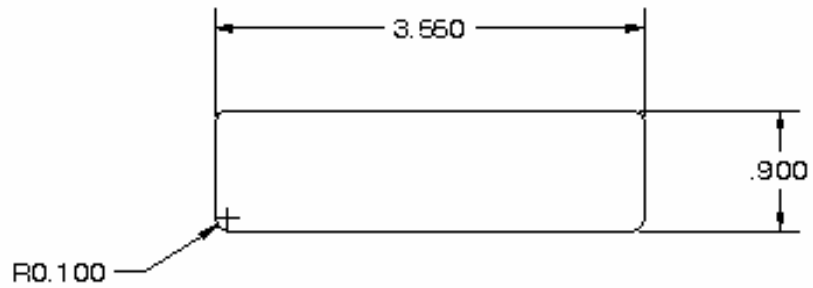
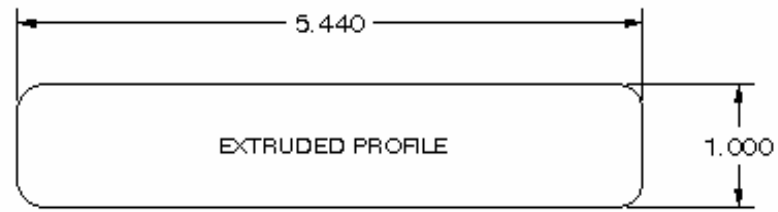

FIGURE 1

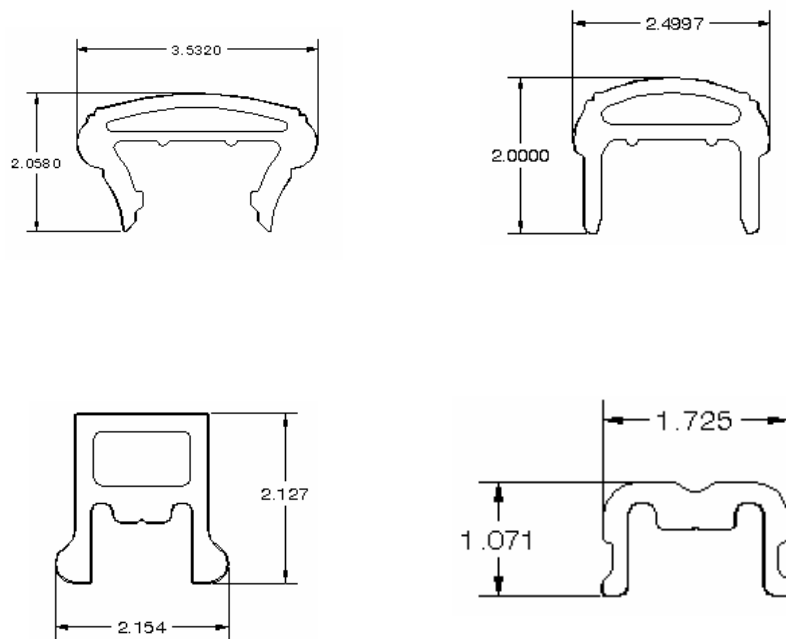
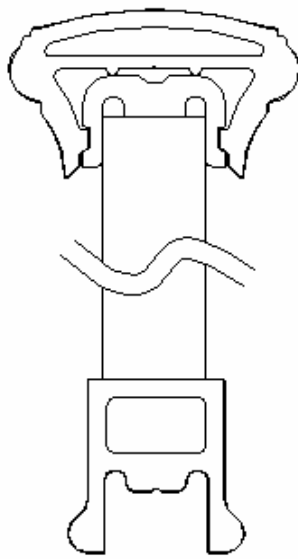
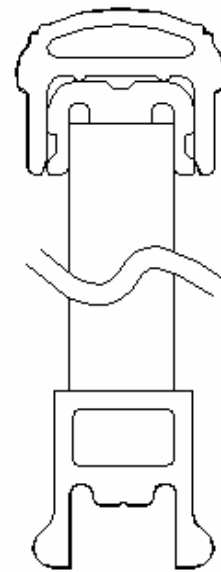

FIGURE 2—COLONIAL RAIL COMPONENTS



3 1/2" COLONIAL ASSEMBLY



2 1/2" COLONIAL ASSEMBLY

FIGURE 3

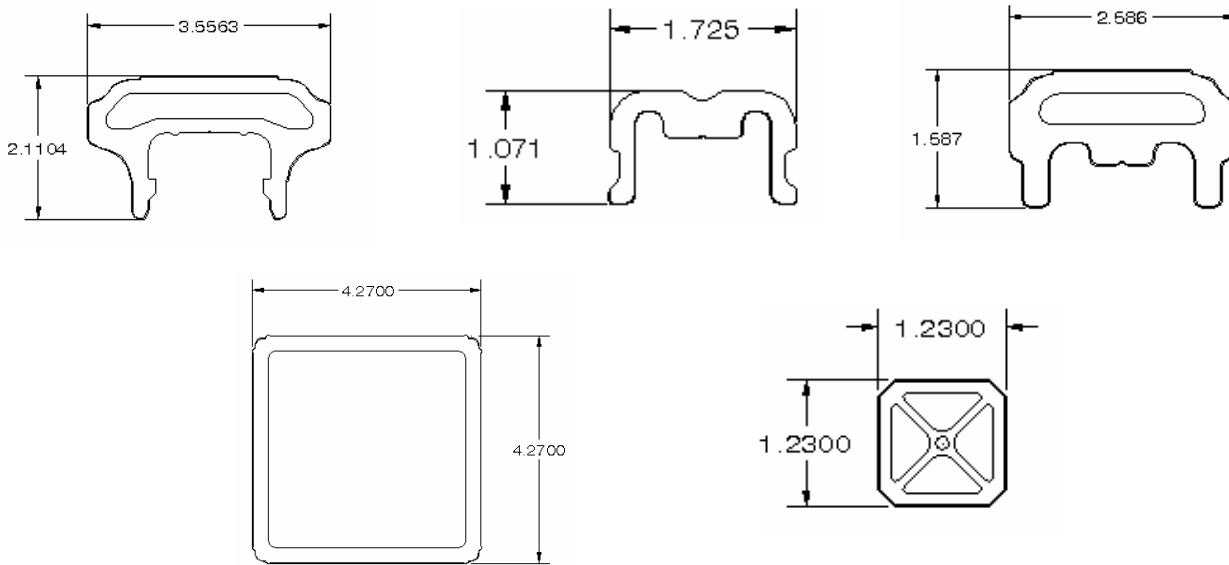

FIGURE 4—VICTORIAN RAIL COMPONENTS

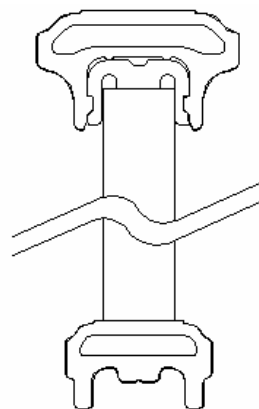

FIGURE 5—3 1/2" VICTORIAN ASSEMBLY

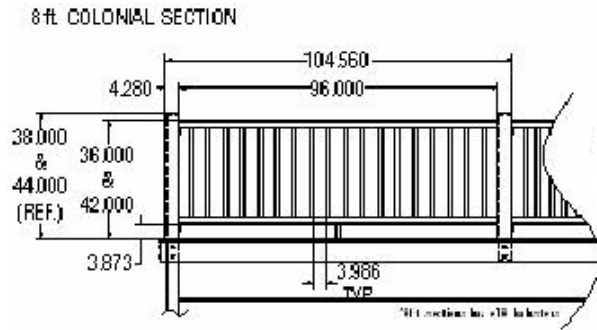

FIGURE 6

Typical Note: The use of the post sleeve installed over insert other than those described in this report is outside the scope of this report.

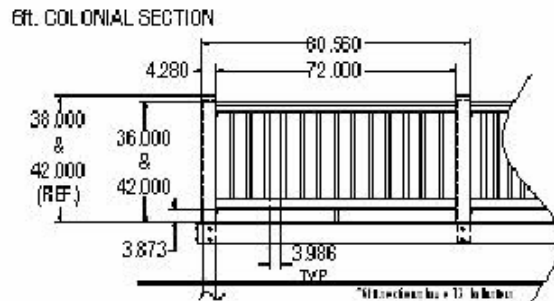

FIGURE 7

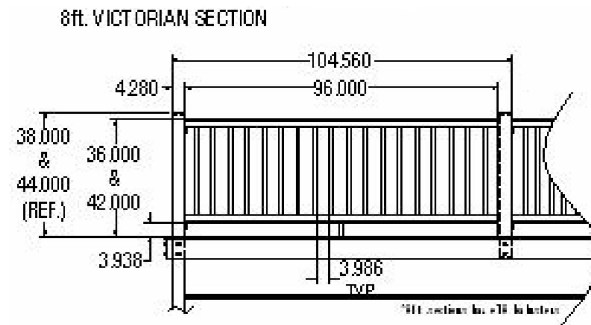

FIGURE 8

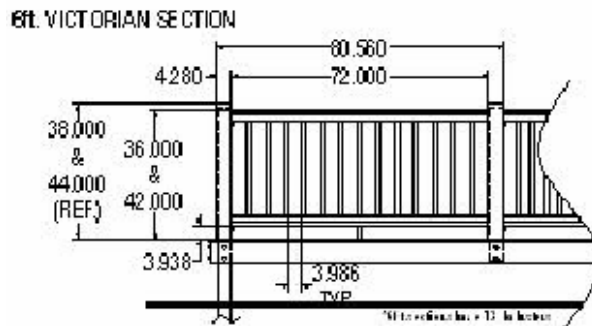

FIGURE 9