

# ICC-ES Evaluation Report

## ESR-1657

Reissued January 1, 2012

This report is subject to renewal in two years.

[www.icc-es.org](http://www.icc-es.org) | (800) 423-6587 | (562) 699-0543

A Subsidiary of the International Code Council®

**DIVISION: 06 00 00—WOOD, PLASTICS AND COMPOSITES**
**Section: 06 50 00—Structural Plastics**
**Section: 06 53 00—Plastic Decking**
**Section: 06 63 00—Plastic Railings**
**REPORT HOLDER:**
**HOMELAND VINYL PRODUCTS, INC.**  
 3300 PINSON VALLEY PARKWAY  
 BIRMINGHAM, ALABAMA 35217  
 (205) 854-4330

[www.homelandvinyl.com](http://www.homelandvinyl.com)
[engineering@homelandvinyl.com](mailto:engineering@homelandvinyl.com)
**EVALUATION SUBJECT:**
**GORILLA DECK™ AND RECTANGULAR, NEXUS® T-RAIL, T-RAIL, AND R-RAIL GUARDRAIL SYSTEMS**
**ADDITIONAL LISTEES:**
**SONCO WORLDWIDE INC.**  
 7 EASTERWOOD STREET, SUITE K  
 MILLVILLE, NEW JERSEY 08332

**SHORELINE VINYL SYSTEMS**  
 11 SUNSET BOULEVARD  
 RIDGELY, MARYLAND 21660

**GREAT RAILINGS INC.**  
 1086 NORTH BLACK HORSE PIKE  
 WILLIAMSTOWN, NEW JERSEY 08094

**1.0 EVALUATION SCOPE**
**Compliance with the following codes:**

- 2009 *International Building Code*® (2009 IBC)
- 2009 *International Residential Code*® (2009 IRC)
- 2006 *International Building Code*® (2006 IBC)
- 2006 *International Residential Code*® (2006 IRC)

**Properties evaluated:**

- Structural
- Durability
- Surface-burning characteristics

**2.0 USES**

The Homeland® Vinyl Products, Inc., Gorilla Deck® described in this report is limited to exterior use as a deck board for balconies, porches and decks of Type V-B construction (IBC) and other types of construction in applications where untreated wood is permitted by IBC Section 1406.3, or in structures constructed in accordance with the IRC.

The Homeland Vinyl Products, Inc., Rectangular top rail system (Rectangular), Bracketed-Tee top rail systems (T-Rail and Nexus® T-Rail) and Bracketed-Bread Loaf top rail system (R-Rail) described in this report are limited to exterior use as guards for balconies, porches, and decks of structures of Type V-B construction (IBC) and other types of construction in applications where untreated wood is permitted by IBC Section 1406.3, or in structures constructed in accordance with the IRC.

**3.0 DESCRIPTION**
**3.1 General:**

The Gorilla Deck® and Rectangular, T-Rail, Nexus® T-Rail and R-Rail systems are poly vinyl chloride (PVC) products manufactured by an extrusion process in three colors: tan, white, and adobe.

**3.2 Deck Board:**

**3.2.1 General:** The Gorilla Deck® is manufactured with nominal dimensions of 1<sup>1</sup>/<sub>4</sub> by 7 inches (32 by 178 mm), with the actual measurements being 1.25 by 7.02 inches (32 by 180 mm), and is available in typical lengths of 16, 20 and 24 feet (4878, 6096 and 7315 mm). The deck board is fabricated with a profile that is designed to interlock during installation. See Figure 1 for a typical cross section.

**3.2.2 Durability:** When subjected to weathering, insect attack, and other decaying elements, material used to manufacture the Gorilla Deck® is equivalent in durability to preservative-treated or naturally durable lumber when used in locations described in Section 2.0. The Gorilla Deck® has been evaluated for structural performance when exposed to a temperature range from -20°F to 125°F (-29°C to 52°C).

**3.2.3 Surface-burning Characteristics:** When tested in accordance with ASTM E 84, the Gorilla Deck® has a flame-spread index of no greater than 200.

**3.3 Guardrail Systems:**

**3.3.1 General:** The Rectangular, T-Rail and R-Rail systems are designed for installed heights of 36 and 42 inches (914 mm and 1067 mm) when used in IRC applications and 42 inches (1067 mm) when used in IBC applications with a maximum length of 96 inches (2438 mm) when measured from the edge-of-structure to edge-of-structure. The Rectangular, T-Rail and R-Rail systems are comprised of several different types of interchangeable components. These include a rectangular rail, T-Rail and R-Rail as top rail components, three different sizes of balusters, a bottom rail, and various mounting brackets and architectural components as described in the manufacturer's quality control manual. The Nexus® T-Rail system is designed for an installed height of 42 inches

(1067 mm) when used in IBC applications and is designed for installed heights of 36 inches (914 mm) or 42 inches (1067 mm) when used in IRC applications. The Nexus® T-Rail system, when constructed under the IBC for other than one- and two-family dwellings, has a maximum length of 96 inches (2438 mm) when measured from the edge-of-structure to edge-of-structure, and 120 inches (3048 mm) when used in IRC applications and one- and two-family dwellings constructed under the IBC. See Figure 2 for typical component cross sections.

**3.3.1.1 Rectangular Rail:** The rectangular rail is manufactured with dimensions of 2 by 3<sup>1</sup>/<sub>2</sub> inches (51 by 89 mm) and a wall thickness of 0.095 inch (2.4 mm). The rail, when used as a top rail, is designed to be installed with a P-channel insert fabricated from 6063-T6 aluminum alloy.

**3.3.1.2 T-Rail:** The T-Rail is a Tee-shaped component with a width of 3<sup>1</sup>/<sub>2</sub> inches (89 mm), a depth of 3<sup>1</sup>/<sub>2</sub> inches (89 mm) and a wall thickness of 0.090 inch (2.3 mm). The T-Rail is designed to be installed with a P-channel insert fabricated from 6063-T6 aluminum alloy.

**3.3.1.3 R-Rail:** The R-Rail is a bread loaf-shaped component with a width of 3 inches (76 mm), a depth of 3<sup>1</sup>/<sub>2</sub> inches (89 mm) and a wall thickness of 0.125 inch (3.2 mm). The R-Rail is designed to be installed with a 2.7-by-0.80-inch (69 by 20.3 mm) 6063-T6 aluminum alloy insert.

**3.3.1.4 Nexus® T-Rail:** The Nexus® T-Rail is a tee-shaped component with a width of 3 inches (76 mm), a depth of 1<sup>3</sup>/<sub>4</sub> inches (44 mm) and a wall thickness of 0.065 inch (1.7 mm). The Nexus® T-Rail is designed to be installed with a 1.55-by-2.78-inch (39 by 71 mm), U-profile, 6063-T6 aluminum insert in guard widths up to 8-feet and a T-profile aluminum insert in guard widths up to 10 feet.

**3.3.1.5 Baluster:** The balusters are fabricated in three sizes: 1<sup>1</sup>/<sub>4</sub> by 1<sup>1</sup>/<sub>4</sub> inches (32 by 32 mm) with a wall thickness of 0.07 inch (1.8 mm); 1<sup>3</sup>/<sub>8</sub> by 1<sup>3</sup>/<sub>8</sub> inches (35 by 35 mm) with a wall thickness of 0.07 inch (1.8 mm); and 1<sup>1</sup>/<sub>2</sub> by 1<sup>1</sup>/<sub>2</sub> inches (38 by 38 mm) with a wall thickness of 0.07 inch (1.8 mm).

**3.3.2 Durability:** When subjected to weathering, insect attack, and other decaying elements, material used to manufacture Rectangular, T-Rail, Nexus® T-Rail and R-Rail systems are equivalent in durability to preservative-treated or naturally durable lumber when used in locations described in Section 2.0. Gorilla Deck® has been evaluated for structural performance when exposed to a temperature range from -20°F to 125°F (-29°C to 52°C).

**3.3.3 Surface-burning Characteristics:** When tested in accordance with ASTM E 84, Rectangular, T-Rail, Nexus® T-Rail and R-Rail systems have a flame-spread index of no greater than 200.

## 4.0 DESIGN AND INSTALLATION

### 4.1 General:

Installation of the Gorilla Deck®, Rectangular, T-Rail, Nexus® T-Rail and R-Rail systems must comply with this report and the manufacturer's published installation instructions. The manufacturer's published installation instructions must be available at the jobsite at all times during installation.

### 4.2 Deck Boards:

**4.2.1 General:** When installing the first board of the Gorilla Deck®, a starter strip must be installed utilizing a No. 8 by 1<sup>1</sup>/<sub>2</sub>-inch (38 mm) stainless steel pan head screw at each support. The first board is snapped into the starter strip and fastened in the same manner as the starter strip. Each subsequent board is installed by snapping into the

previous board and fastening in the same manner. Fasteners must be installed a minimum of <sup>3</sup>/<sub>4</sub> inch (19 mm) from the end of each board. Butt joints must be supported with a double joist allowing a gap as recommended by the manufacturer's published installation instructions. The deck boards must not extend past the last support.

**4.2.2 Structural:** The Gorilla Deck®, when used as a deck board, will have an allowable capacity, when installed at a maximum center-to-center spacing of the supporting construction, as prescribed in Table 1.

### 4.3 Guardrail:

**4.3.1 General:** The Rectangular, T-Rail, Nexus® T-Rail and R-Rail systems are assembled using a bracketed component assembly. The balusters are installed by insertion into a routed opening. The routed openings are fabricated so that a maximum opening of 3.9 inches (99 mm) between balusters is maintained. One 1<sup>1</sup>/<sub>2</sub>-by-1<sup>1</sup>/<sub>2</sub>-inch-square footblock is installed at the midpoint of the bottom rail. The bottom rail of the Nexus® T-Rail system includes additional reinforcement. The bottom rail of the Rectangular, T-Rail and R-Rail systems is installed without any additional reinforcement.

**4.3.2 Bracketed Component Assembly:** The brackets used to attach the top and bottom rails to structures and the top rail to the bracket must be attached as shown in Table 3. The Rectangular, T-Rail and R-Rail systems use a plastic bracket. The Nexus® T-Rail system uses an aluminum bracket. The top rail components must be reinforced as described in Sections 3.3.1.1, 3.3.1.2, 3.3.1.3 and 3.3.1.4 respectively.

**4.3.3 Structural:** The Rectangular, T-Rail, Nexus® T-Rail and R-Rail systems will resist the loads specified in the applicable code when installed at a maximum length as prescribed in Table 2.

## 5.0 CONDITIONS OF USE

The Gorilla Deck® and Rectangular, T-Rail, Nexus® T-Rail and R-Rail systems described in this report comply with, or are suitable alternatives to what is specified in, those codes listed in Section 1.0 of this report, subject to the following conditions:

- 5.1** The Gorilla Deck® described in this report is limited to exterior use as a deck board for balconies, porches and decks of Type V-B construction (IBC) and structures constructed in accordance with the IRC.
- 5.2** The Rectangular, T-Rail, Nexus® T-Rail and R-Rail systems described in this report are limited to exterior use as guards for balconies, porches, and decks of structures of Type V-B construction (IBC) and other types of construction in applications where untreated wood is permitted by IBC Section 1406.3, or in structures constructed in accordance with the IRC.
- 5.3** Installation must comply with this report, the manufacturer's published installation instructions and the applicable code. Only those fasteners and fastener configurations described in this report have been evaluated for the installation of the Gorilla Deck® and Rectangular, T-Rail, Nexus® T-Rail and R-Rail systems. When the manufacturer's published installation instructions differ from this report, this report governs.
- 5.4** The use of the Gorilla Deck® as a component of a fire-resistance-rated assembly is outside the scope of this report.
- 5.5** The Gorilla Deck® has been evaluated for installation across a minimum of three supports (two-span condition). If installed in a single span condition, the maximum allowable uniform load specified in Table 1 must be reduced 5 percent.

- 5.6 The use of wood posts, with or without post sleeves, is outside the scope of this report.
- 5.7 The compatibility of the fasteners and other metal hardware with the supporting construction, including chemically treated wood, is outside the scope of this report.
- 5.8 Adjustment factors outlined in the AF&PA *National Design Specification* and applicable codes must not apply to the allowable capacity and maximum spans for the Gorilla Deck<sup>®</sup> and Rectangular, T-Rail, Nexus<sup>®</sup> T-Rail and R-Rail systems.
- 5.9 The use of the Gorilla Deck<sup>®</sup> as a stair tread is outside the scope of this report.
- 5.10 The Gorilla Deck<sup>®</sup> and Rectangular, T-Rail, Nexus<sup>®</sup> T-Rail and R-Rail systems must be fastened directly to supporting construction. Where required by the code official, engineering calculations and construction documents consistent with this report must be submitted for approval. The calculations must verify that the supporting construction complies with the applicable building code requirements and is adequate to resist the loads imparted upon it from the products and systems discussed in this report. The documents must contain details of the attachment to the supporting structure consistent with the requirements of this report. The documents must be prepared by a registered design professional where

required by the statutes of the jurisdiction in which the project is to be constructed.

5.11 The Gorilla Deck<sup>®</sup> and Rectangular, T-Rail, Nexus<sup>®</sup> T-Rail and R-Rail systems are produced in Birmingham, Alabama, under a quality control program with inspections by RADCO (AA-650).

**6.0 EVIDENCE SUBMITTED**

Data establishing compliance of the guard system with the ICC-ES Acceptance Criteria for Deck Board Span Ratings and Guardrail Systems (Guards and Handrails) (AC174), dated July 2010.

**7.0 IDENTIFICATION**

The Gorilla Deck<sup>®</sup> described in this report is identified on each package by a label bearing the manufacturer’s name (Homeland Vinyl Products, Inc.); the product name; the date of manufacture; the span rating, the name of the inspection agency (RADCO); and the evaluation report number (ESR-1657).

The Rectangular, T-Rail, Nexus<sup>®</sup> T-Rail and R-Rail systems described in this report are identified on each package by a stamp bearing the manufacturer’s name (Homeland Vinyl Products, Inc.); the name of the packaging facility; the product name; the allowable span, the date of manufacture; the name of the inspection agency (RADCO); and the evaluation report number (ESR-1657).

**TABLE 1—DECK BOARD SPAN RATING**

DECKBOARD	MAXIMUM SPAN (in.)	ALLOWABLE CAPACITY (lb/ft <sup>2</sup> ) <sup>2,3</sup>
Gorilla Deck <sup>®</sup>	24	100

For SI: 1 inch = 25.4mm, 1 lb/ft<sup>2</sup> = 47.9 Pa.

<sup>1</sup>Maximum span must be measured center-to-center of the supporting construction.

<sup>2</sup>Maximum allowable capacity has been adjusted for durability. No further increases are permitted.

<sup>3</sup>The Gorilla Deck<sup>™</sup> has been evaluated for installation across a minimum of three supports (two-span condition). If installed in a single span condition, the maximum allowable uniform load must be reduced 5 percent.

**TABLE 2—MAXIMUM GUARDRAIL SPAN<sup>2</sup>**

PRODUCT NAME	APPLICABLE BUILDING CODE <sup>3</sup>		MAXIMUM SPAN (ft-in) <sup>1</sup>
	IBC	IRC	
Rectangular Rail	Yes	Yes	8’ – 0”
T-Rail	Yes	Yes	8’ – 0”
R-Rail	Yes	Yes	8’ – 0”
Nexus <sup>®</sup> T-Rail	Yes	Yes	8’ – 0”
Nexus <sup>®</sup> T-Rail	Note 4	Yes	10’ – 0”

For SI: 1 inch = 25.4 mm, 1 ft = 305 mm.

<sup>1</sup>Maximum span must be measured from edge-of-structure to edge-of-structure.

<sup>2</sup>Maximum allowable span has been adjusted for durability. No further increases are permitted.

<sup>3</sup>Indicates compliance with the respective building codes.

<sup>4</sup>Allowed in one- and two-family dwellings only

**TABLE 3—GUARD FASTENING SCHEDULE**

GUARD SYSTEM	CONNECTION	FASTENERS
T-Rail	Rail Bracket to Post	Six No. 10 - 10-by-1 <sup>1</sup> / <sub>2</sub> inch, Phillips pan-head, self-drilling, plated steel screw
	Rail Bracket to Rail	Two No. 10 - 10-by-1 inch Phillips pan-head, self-drilling, plated steel screw
R-Rail	Rail Bracket to Post	Four No. 10-by-2 inch stainless steel wood screws
	Rail Bracket to Rail	Two No. 10-by-1 inch stainless steel pan head screws
2 by 3 <sup>1</sup> / <sub>2</sub> (Rectangular)	Rail Bracket to Post	Four No. 10 - 10-by-1 <sup>1</sup> / <sub>2</sub> inch, Phillips pan-head, self-drilling, plated steel screw
	Rail Bracket to Rail	Two No. 10 - 10-by-1 inch Phillips pan-head, self-drilling, plated steel screw
Nexus <sup>®</sup> T-Rail	Rail Bracket to Post	Three No. 8 - 8-by-1 <sup>5</sup> / <sub>8</sub> inch, flat-head, #2 square-drive, Type 17 point, stainless steel screws
	Rail Bracket to Rail	Two No. 10 - 16-by- <sup>3</sup> / <sub>4</sub> inch, pan-head, #2 square drive, plated steel, Tek screws

For SI: 1 inch = 25.4 mm.

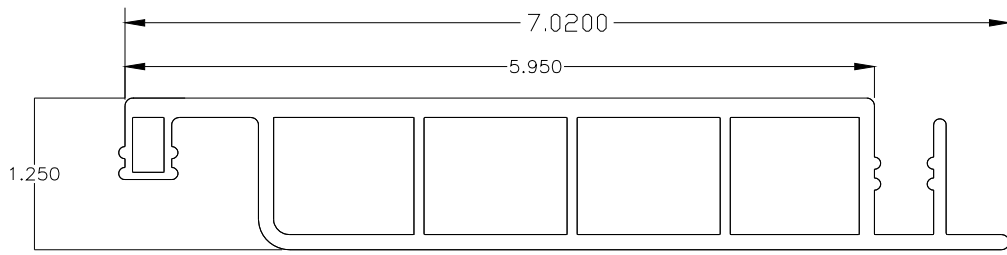

For SI: 1 inch = 25.4 mm.

FIGURE 1—GORILLA DECK® CROSS SECTION

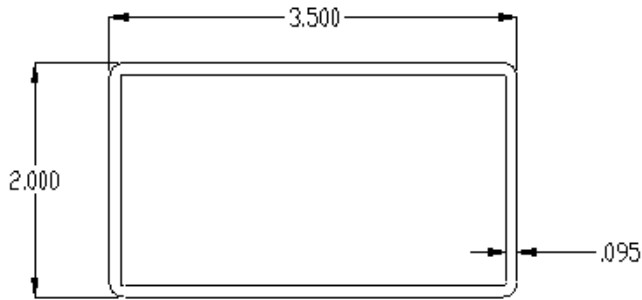

RECTANGULAR TOP RAIL

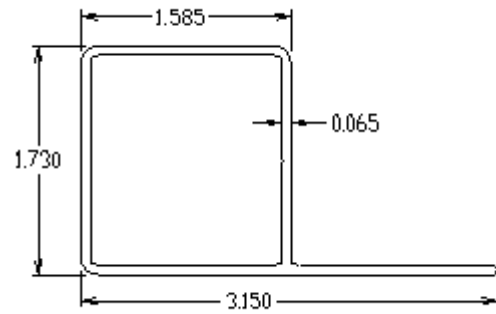

ALUMINUM P-CHANNEL RAIL INSERT

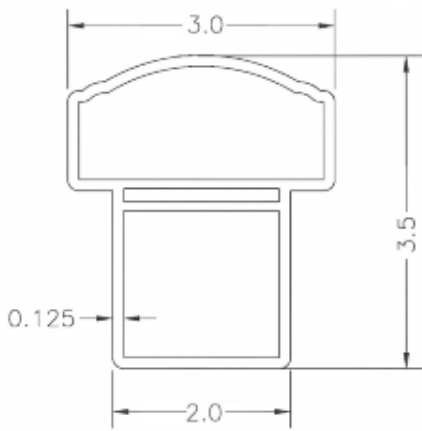

R-RAIL RAIL

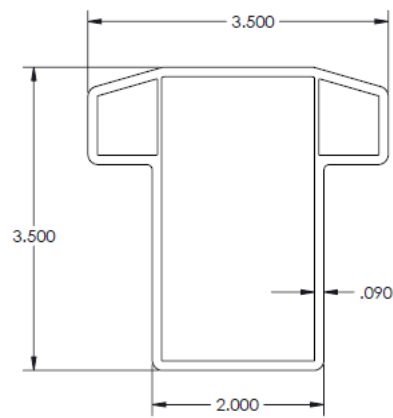

T-RAIL RAIL

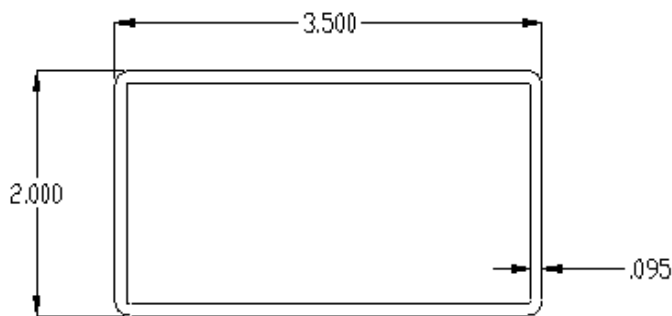

BOTTOM RAIL

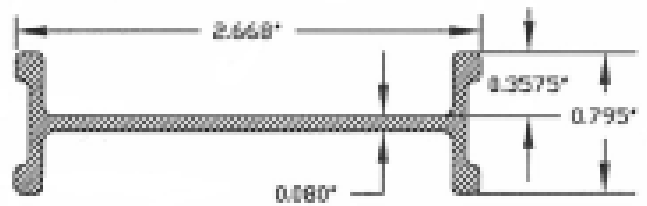

ALUMINUM RAIL INSERT

FIGURE 2—GUARDRAIL COMPONENT PROFILES

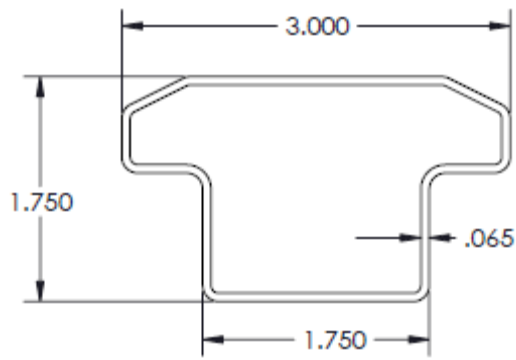

**NEXUS T-RAIL**

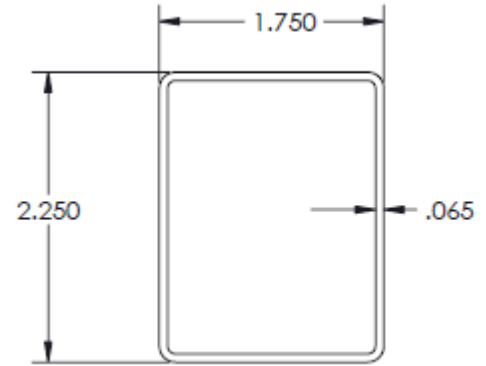

**NEXUS T-RAIL BOTTOM RAIL**

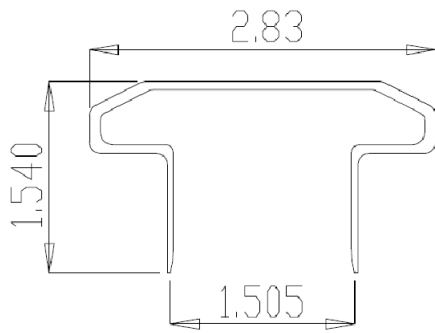

**NEXUS CONTOUR INSERT**

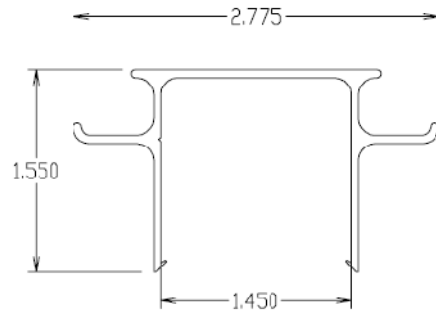

**NEXUS MODIFIED U INSERT**

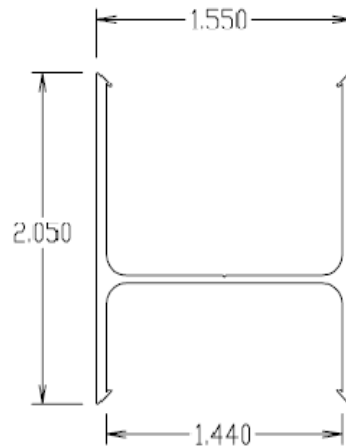

**NEXUS BOTTOM RAIL INSERT**

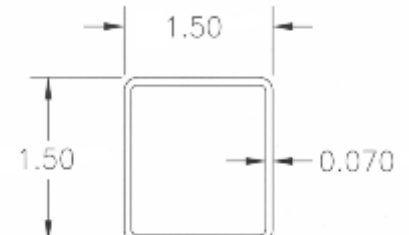
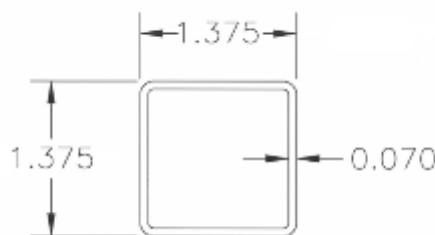
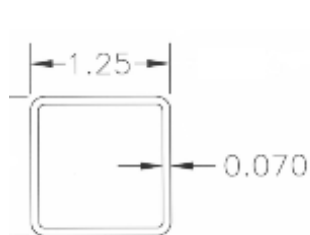

**BALUSTERS**

For SI: 1 inch = 25.4 mm.

**FIGURE 2—GUARDRAIL COMPONENT PROFILES (Continued)**