

ICC-ES Evaluation Report

ESR-1771*

Issued August 1, 2008

This report is subject to re-examination in two years.

www.icc-es.org | (800) 423-6587 | (562) 699-0543

A Subsidiary of the International Code Council®

DIVISION: 03—CONCRETE
Section: 03151—Concrete Anchoring
REPORT HOLDER:

SIMPSON STRONG-TIE COMPANY, INC.
5956 WEST LAS POSITAS BOULEVARD
PLEASANTON, CALIFORNIA 94588
(800) 999-5099
www.simpsonanchors.com

EVALUATION SUBJECT:
STRONG-BOLT™ WEDGE ANCHOR FOR CRACKED AND UNCRACKED CONCRETE
1.0 EVALUATION SCOPE
Compliance with the following codes:

- 2006 *International Building Code*® (2006 IBC)
- 2006 *International Residential Code*® (2006 IRC)
- 2003 *International Building Code*® (2003 IBC)
- 2003 *International Residential Code*® (2003 IRC)
- 1997 *Uniform Building Code*™ (UBC)

Properties evaluated:

Structural

2.0 USES

The Simpson Strong-Tie Strong-Bolt™ Wedge Anchor is used to resist static, wind and seismic tension and shear loads in cracked and uncracked normal-weight concrete and structural sand-lightweight concrete members having a specified compressive strength, f'_c , of 2,500 psi to 8,500 psi (17.2 MPa to 58.6 MPa); and cracked and uncracked structural sand lightweight or normal-weight concrete over profile steel deck having a minimum specified compressive strength, f'_c , of 3,000 psi (20.7 MPa).

The Strong-Bolt™ is an alternative to cast-in-place anchors described in Sections 1911 and 1912 of the 2006 IBC, Sections 1912 and 1913 of the 2003 IBC, and Sections 1923.1 and 1923.2 of the UBC. The anchors may also be used where an engineering design is submitted in accordance with Section R301.1.3 of the 2006 and 2003 IRC.

3.0 DESCRIPTION
3.1 Strong Bolt™:

Strong-Bolt™ anchors are torque-controlled mechanical expansion anchors consisting of an anchor body, expansion clip, nut, and washer. A typical anchor is shown in Figure 1. The 1/2-inch-, 5/8-inch-, and 3/4-inch-diameter (12.7 mm, 15.9 mm, and 19.1 mm) anchor bodies are manufactured from carbon steel conforming to SAE J403, Grade 1030 to 1035. The 1-inch-diameter (25.4 mm) anchor body is manufactured from carbon steel conforming to SAE J403 Grade 12L14. The anchor bodies are zinc plated in accordance with ASTM B 633, SC1, Type 1. The expansion clip is fabricated from ASTM A 240, Grade 316, stainless steel. The washer conforms to ASTM F 844. The hex nut conforms to ASTM A 563, Grade A.

The anchor body has a tapered mandrel formed on the installed end of the anchor and a threaded section at the opposite end. The taper of the mandrel increases in diameter toward the installed end of the anchor. The three-segment expansion clip wraps around the tapered mandrel. Before installation, this expansion clip is free to rotate about the mandrel. The anchor is installed in a predrilled hole. When the anchor is set using an applied torque to the hex nut, the mandrel is drawn into the expansion clip, which engages the drilled hole and transfers the load to the base material. Pertinent dimensions are as set forth in Table 1.

3.2 Concrete:

Normal-weight and structural sand-lightweight concrete must conform to Sections 1903 and 1905 of the IBC or UBC, as applicable. For placement over profile steel deck floor and roof assemblies, structural sand lightweight or normal-weight concrete is required.

4.0 DESIGN AND INSTALLATION
4.1 Strength Design:

Anchor design strengths, ϕN_n and ϕV_n , must be determined in accordance with ACI 318-05 Appendix D and this report. Design parameters are provided in Tables 2, 3, and 4 and Figures 2 and 3 of this report. The anchor design must satisfy the requirements in ACI 318 Sections D.4.1.1 and D.4.1.2. Strength reduction factors, ϕ , described in ACI 318 Section D.4.4, and noted in Tables 2 and 3 of this report, must be used for load combinations calculated in accordance with Section 1605.2.1 of the IBC or Section 1612.2.1 of the UBC.

*Revised June 2009

Strength reduction factors, ϕ , described in ACI 318 Section D.4.5 must be used for load combinations calculated in accordance with Appendix C of ACI 318 or Section 1909.2 of the UBC. An example calculation is provided in Figure 4.

4.1.1 Static Steel Strength in Tension: The nominal steel strength in tension, N_{sa} , in accordance with ACI 318 Section D.5.1.2, is given in Table 2 of this report. The strength reduction factor, ϕ , corresponding to a ductile steel element must be used for 1/2-inch-, 5/8-inch- and 1-inch-diameter (12.7 mm, 15.9 mm and 25.4 mm) anchors, and the strength reduction factor for a brittle steel element must be used for the 3/4-inch-diameter (19.1 mm), described in Table 2 of this report.

4.1.2 Static Concrete Breakout Strength in Tension: The nominal concrete breakout strength in tension, N_{cb} and N_{cbg} , must be calculated in accordance with ACI 318 Section D.5.2, with modifications as described in this section. The basic concrete breakout strength in tension, N_b , must be calculated in accordance with ACI 318 Section D.5.2.2 using the values of h_{ef} and k_c as described in Table 2 of this report. The value of f'_c must be limited to 8,000 psi (55.2 MPa), in accordance with ACI 318 Section D.3.5. The nominal concrete breakout strength in tension, N_{cb} or N_{cbg} , in regions of a concrete member where analysis indicates no cracking at service loads in accordance with ACI 318 Section D.5.2.6, must be calculated with the value of $\psi_{c,N}$, as described in Table 2 of this report.

For anchors installed in the soffit of structural sand lightweight or normal-weight concrete over profile steel deck floor and roof assemblies, as shown in Figure 3, determination of the concrete breakout strength in accordance with ACI 318 Section D.5.2 is not required.

4.1.3 Static Pullout Strength in Tension: The nominal pullout strength in accordance with ACI 318 Section D.5.3 in cracked and uncracked concrete, $N_{pn,cr}$ and $N_{pn,un-cr}$, respectively, is described in Table 2 of this report. In regions of a concrete member where analysis indicates no cracking in accordance with ACI 318 Section D.5.3.6, the nominal pullout strength in uncracked concrete, $N_{pn,un-cr}$ applies. In accordance with ACI 318 Section D.5.3.2, the appropriate value for nominal pullout strength, $N_{pn,cr}$ or $N_{pn,un-cr}$, is used in lieu of N_{pn} . Where values for $N_{pn,cr}$ or $N_{pn,un-cr}$ are not provided in Table 2, the pullout strength does not need to be considered.

The pullout strength in cracked concrete for anchors installed in the soffit of structural sand lightweight or normal-weight concrete over profile steel deck floor and roof assemblies, as shown in Figure 3, is given in Table 4. In accordance with ACI 318 Section D.5.3.2, the nominal pullout strength in cracked concrete must be calculated as stated previously in this section, using the value of $N_{pn,deck,cr}$ in lieu of $N_{pn,cr}$. In regions of a concrete member where analysis indicates no cracking in accordance with ACI 318 Section D.5.3.6, the nominal pullout strength in uncracked concrete must be calculated as stated previously in this section, using the value of $N_{pn,deck,un-cr}$ in lieu of $N_{pn,un-cr}$. The minimum anchor spacing along the flute must be the greater of $3.0h_{ef}$ or 1.5 times the flute width. The value of $\psi_{c,p}$ is 1.0 for all cases.

4.1.4 Static Steel Strength in Shear: The nominal steel strength in shear, V_{sa} , in accordance with ACI 318 Section D.6.1.2, is given in Table 3 of this report. The strength reduction factor, ϕ , corresponding to a ductile steel element must be used for 1/2-inch-, 5/8-inch- and 1-

inch-diameter (12.7 mm, 15.9 mm and 25.4 mm) anchors, and the strength reduction factor corresponding to a brittle steel element must be used for the 3/4-inch-diameter (19.1 mm) anchor, described in Table 3 of this report.

The shear strength, $V_{st,deck}$ of anchors installed in the soffit of structural sand lightweight or normal-weight concrete over profile steel deck floor and roof assemblies, as shown in Figure 3, is given in Table 4.

4.1.5 Static Concrete Breakout Strength in Shear: The nominal concrete breakout strength in shear, V_{cb} and V_{cbg} , must be calculated in accordance with ACI 318 Section D.6.2, with modifications as described in this section. The basic concrete breakout strength in shear, V_b , must be calculated in accordance with ACI 318 Section D.6.2.2 using the values of l_e and d_o described in Table 3 of this report. The value of f'_c must be limited to a maximum of 8,000 psi (55.2 MPa) in accordance with ACI 318 Section D.3.5.

For anchors installed in the soffit of structural sand lightweight or normal-weight concrete over profile steel deck floor and roof assemblies, as shown in Figure 3, calculation of the concrete breakout strength in accordance with ACI 318 Section D.6.2 is not required.

4.1.6 Static Concrete Pryout Strength in Shear: The nominal concrete pryout strength, V_{cp} and V_{cpg} , must be calculated in accordance with ACI 318 Section D.6.3, modified by using the value of k_{cp} described in Table 3 of this report and the value of N_{cb} or N_{cbg} as calculated in Section 4.1.2 of this report. For anchors installed in the soffit of structural sand lightweight or normal-weight concrete over profile steel deck floor and roof assemblies, as shown in Figure 3, calculation of the concrete pryout strength in accordance with ACI 318 Section D.6.3 is not required.

4.1.7 Requirements for Seismic Design:

4.1.7.1 General: For load combinations including seismic, the design must be performed in accordance with ACI 318 Section D.3.3, as modified by Section 1908.1.16 of the 2006 IBC or the following:

CODE	ACI 318 SECTION D.3.3 SEISMIC REGION	CODE EQUIVALENT DESIGNATION
2003 IBC and 2003 IRC	Moderate or high seismic risk	Seismic Design Categories C, D, E, and F
1997 UBC	Moderate or high seismic risk	Seismic Zones 2B, 3, and 4

Except for anchors used under Seismic Design Categories A and B (IBC) or Seismic Zones 1 and 2A (UBC), design strengths must be determined presuming cracked concrete. The 1/2-inch-, 5/8-inch- and 1-inch-diameter (12.7 mm, 15.9 mm and 25.4 mm) anchors comply with ACI 318 Section D.1 as ductile steel elements and must be designed in accordance with ACI Section D.3.3.4 or D.3.3.5, as modified by Section 1908.1.16 of the 2006 IBC, in Seismic Design Categories C, D, E, or F (IBC) or Seismic Zones 2B, 3, or 4 (UBC). The 3/4-inch-diameter (19.1 mm) anchors must be designed in accordance with ACI Section D.3.3.5 as modified by Section 1908.1.16 of the 2006 IBC in Seismic Design Categories C, D, E, or F (IBC) or Seismic Zones 2B, 3, or 4 (UBC).

4.1.7.2 Seismic Tension: The nominal steel strength and concrete breakout strength in tension must be calculated in accordance with ACI 318 Sections D.5.1

and D.5.2, as described in Sections 4.1.1 and 4.1.2 of this report. In accordance with ACI 318 Section D.5.3.2, the appropriate value for nominal pullout strength in tension for seismic loads, $N_{pn,eq}$ or $N_{pn,deck,cr}$, described in Tables 2 and 4 of this report must be used in lieu of N_{pn} .

4.1.7.3 Seismic Shear: The nominal concrete breakout and concrete pryout strength in shear must be calculated in accordance with ACI 318 Sections D.6.2 and D.6.3, as described in Sections 4.1.5 and 4.1.6 of this report. In accordance with ACI 318 Section 6.1.2, the appropriate value for nominal steel strength in shear for seismic loads, $V_{sa,eq}$ or $V_{st,deck}$, described in Table 3 and 4 of this report, must be used in lieu of V_{sa} .

4.1.8 Interaction of Tensile and Shear Forces: For loadings that include combined tension and shear, the design must be performed in accordance with ACI 318 Section D.7.

4.1.9 Requirements for Minimum Member Thickness, Minimum Anchor Spacing and Minimum Edge Distance: In lieu of using ACI 318 Section D.8.3, values of c_{min} and s_{min} provided in Table 1 of this report must be used. In lieu of using ACI 318 Section D.8.5, minimum member thickness, h_{min} , must be in accordance with Table 1 of this report. In lieu of using ACI 318 Section D.8.6, values of c_{ac} provided in Table 1 of this report must be used.

4.1.10 Structural Sand-lightweight Concrete: When anchors are used in structural sand-lightweight concrete, N_b , N_{pn} , V_b and V_{cp} must be multiplied by 0.60, in lieu of ACI 318 Section D.3.4.

4.2 Allowable Stress Design (ASD):

4.2.1 General: Design values for use with allowable stress design load combinations calculated in accordance with Section 1605.3 of the IBC and Section 1612.3 of the UBC, must be established using the following relationships:

$$T_{allowable,ASD} = \phi N_n / \alpha$$

and

$$V_{allowable,ASD} = \phi V_n / \alpha$$

where:

$T_{allowable,ASD}$ = Allowable tension load (lbf or N).

$V_{allowable,ASD}$ = Allowable shear load (lbf or N).

ϕN_n = The lowest design strength of an anchor or anchor group in tension as determined in accordance with ACI 318 Appendix D, Section 4.1 of this report, and 2006 IBC Section 1908.1.16, as applicable. (lbf or N).

ϕV_n = The lowest design strength of an anchor or anchor group in shear as determined in accordance with ACI 318 Appendix D, Section 4.1 of this report, and 2006 IBC Section 1908.1.16, as applicable. (lbf or N).

α = A conversion factor calculated as a weighted average of the load factors for the controlling load combination. In addition, α shall include all applicable factors to account for non-ductile failure modes and required over-strength.

An example calculation for the derivation of allowable stress design tension values is presented in Table 5.

4.2.2 Interaction of Tensile and Shear Forces: The interaction of tension and shear loads must be consistent with ACI 318 D.7 as follows:

If $T_{applied} \leq 0.2T_{allowable,ASD}$, then the full allowable strength in shear, $V_{allowable,ASD}$, must be permitted.

If $V_{applied} \leq 0.2V_{allowable,ASD}$, then the full allowable strength in tension, $T_{allowable,ASD}$, must be permitted.

For all other cases: $T_{applied} / T_{allowable,ASD} + V_{applied} / V_{allowable,ASD} \leq 1.2$.

4.3 Installation:

Installation parameters are provided in Table 1 and in Figures 2 and 3. Anchor locations must comply with this report and the plans and specifications approved by the code official. The Strong-Bolt™ must be installed in accordance with the manufacturer's published instructions and this report. Anchors must be installed in holes drilled into the concrete using carbide-tipped drill bits conforming to ANSI B212.15-1994. The nominal drill bit diameter must be equal to the nominal diameter of the anchor. The minimum drilled hole depth must equal or exceed the specified embedment depth of the anchor. The drilled hole must be cleaned, with all dust and debris removed using pressurized air. The anchor, nut, and washer must be assembled so that the top of the nut is flush with the top of the anchor. The anchor must be driven into the hole using a hammer until the proper embedment depth is achieved. The nut and washer must be tightened against the base material or material to be fastened until the appropriate installation torque value specified in Table 1 is achieved.

For installation in the soffit of normal-weight or structural sand lightweight concrete over profile steel deck floor and roof assemblies, the hole diameter in the steel deck must not exceed the diameter of the hole in the concrete by more than $\frac{1}{8}$ inch (3.2 mm). Installation torque values for anchors installed in the soffit of structural sand lightweight or normal-weight concrete over profile steel deck floor and roof assemblies, must comply with values in Table 4.

4.4 Special Inspection:

Installations must be made under special inspection in accordance with Section 1704.13 of the IBC and Section 1701.5.2 of the UBC. The special inspector must be on the jobsite continuously during anchor installation to verify anchor type, anchor dimensions, hole cleanliness, embedment depth, concrete type, concrete compressive strength, drill bit diameter, hole depth, edge distance(s), anchor spacing(s), concrete thickness, and tightening torque.

4.5 Jobsite Quality Assurance:

Under the IBC, additional requirements as set forth in Sections 1705 and 1706 must be observed.

5.0 CONDITIONS OF USE

The Simpson Strong-Tie Strong-Bolt™ Wedge Anchor described in this report complies with, or is a suitable alternative to what is specified in, those codes listed in Section 1.0 of this report, subject to the following conditions:

5.1 The anchors must be installed in accordance with the manufacturer's published installation instructions and this report. In cases of a conflict, this report governs.

5.2 Anchor sizes, dimensions and minimum embedment depths are as set forth in the tables of this report.

- 5.3 The anchors must be installed in accordance with Section 5.1 of this report in cracked and uncracked normal-weight and structural sand lightweight concrete having a specified compressive strength, f'_c , of 2,500 psi to 8,500 psi (17.2 MPa to 58.6 MPa); and in cracked and uncracked structural sand lightweight or normal-weight concrete over profile steel deck having a minimum specified compressive strength, f'_c , of 3,000 psi (20.7 MPa).
- 5.4 The value of f'_c used for calculation purposes must not exceed 8,000 psi (55.2 MPa).
- 5.5 Strength design values must be established in accordance with Section 4.1 of this report.
- 5.6 Allowable stress design values are established in accordance with Section 4.2 of this report.
- 5.7 Anchor spacing and edge distance, as well as minimum member thickness, must comply with Tables 1 and 4, and Figure 3, of this report.
- 5.8 Prior to installation, calculations and details demonstrating compliance with this report must be submitted to the code official. The calculations and details must be prepared by a registered design professional where required by the statutes of the jurisdiction in which the project is to be constructed.
- 5.9 Since an ICC-ES acceptance criteria for evaluating data to determine the performance of expansion anchors subjected to fatigue or shock loading is unavailable at this time, the use of these anchors under such conditions is beyond the scope of this report.
- 5.10 Anchors may be installed in regions of concrete where cracking has occurred or where analysis indicates cracking may occur ($f_t > f_t$), subject to the conditions of this report.
- 5.11 Anchors may be used to resist short-term loading due to wind or seismic forces, subject to the conditions of this report.
- 5.12 Where not otherwise prohibited in the code, Strong-Bolt™ anchors are permitted for use with fire-resistance-rated construction provided that at least one of the following conditions is fulfilled:

- Anchors are used to resist wind or seismic forces only.
- Anchors that support a fire-resistance-rated envelope or a fire-resistance-rated membrane, are protected by approved fire-resistance-rated materials, or have been evaluated for resistance to fire exposure in accordance with recognized standards.
- Anchors are used to support nonstructural elements.

5.13 Use of anchors is limited to dry, interior locations.

5.14 Special inspection and jobsite quality assurance must be provided in accordance with Sections 4.4 and 4.5, respectively.

5.15 The anchors are manufactured by Simpson Strong-Tie Company, Inc., in Brampton, Ontario, Canada, under a quality control program with inspections by CEL Consulting (AA-639).

6.0 EVIDENCE SUBMITTED

Data in accordance with the ICC-ES Acceptance Criteria for Mechanical Anchors in Concrete Elements (AC193), dated June 2008, including optional suitability tests 12 and 13 for seismic tension and shear; profile steel deck soffit tests; mechanical properties tests; calculations; and a quality control manual.

7.0 IDENTIFICATION

The Strong-Bolt™ anchors are identified in the field by dimensional characteristics and packaging. The Strong-Bolt™ anchor has the Simpson Strong-Tie Company, Inc., No Equal logo ≠ stamped on the expansion clip, and a length identification code embossed on the exposed threaded end. Table 6 shows the length identification codes. The packaging label bears the manufacturer's name and contact information, anchor name, anchor size and length, quantity, the evaluation report number (ICC-ES ESR-1771), and the name of the inspection agency (CEL Consulting).

TABLE 1—STRONG-BOLT™ INSTALLATION INFORMATION¹

CHARACTERISTIC	SYMBOL	UNITS	NOMINAL ANCHOR DIAMETER (inch)										
			1/2			5/8			3/4			1	
Installation Information													
Nominal Diameter	d_o	in.	1/2			5/8			3/4			1	
Drill Bit Diameter	d	in.	1/2			5/8			3/4			1	
Baseplate Clearance Hole Diameter ²	d_c	in.	9/16			11/16			7/8			1 1/8	
Installation Torque	T_{inst}	ft-lbf	50			85			180			230	
Embedment Depth	h_{nom}	in.	2 3/4	3 7/8	5	3 3/8	5 1/8	6 1/8	4 1/8	5 3/4	7 1/2	5 1/4	9 3/4
Effective Embedment Depth	h_{ef}	in.	2 1/4	3 3/8	4 1/2	2 3/4	4 1/2	5 1/2	3 3/8	5	6 3/4	4 1/2	9
Critical Edge Distance	c_{ac}	in.	9	7 7/8	6 3/4	11	9 5/8	8 1/4	13 1/2	11 3/4	10 1/8	18	13 1/2
Minimum Edge Distance	c_{min}	in.	4			5			6			8	
Minimum Spacing	s_{min}	in.	4			6 1/4			6 1/4			8	
Minimum Concrete Thickness	h_{min}	in.	4 1/2	6	6 3/4	5 1/2	7 7/8	8 1/4	6 3/4	8 3/4	10 1/8	9	13 1/2
Anchor Data													
Specified Yield Strength of Anchor Steel	f_{ya}	psi	108,000										60,000
Specified Tensile Strength of Anchor Steel	f_{uta}	psi	125,000										78,000
Effective Tensile and Shear Stress Area	A_{se}	in ²	0.108			0.167			0.273			0.472	
Axial Stiffness in Service Load Range	β	lb/in.	125,000			141,000			225,000			299,600	

For **SI**: 1 inch = 25.4 mm, 1 ft-lbf = 1.356 N-m, 1 psi = 6.89 Pa, 1 in² = 645 mm², 1 lb/in = 0.175 N/mm.

¹The information presented in this table is to be used in conjunction with the design criteria of ACI 318 Appendix D.

²The clearance must comply with applicable code requirements for the connected element.

TABLE 2—STRONG-BOLT™ CHARACTERISTIC TENSION STRENGTH DESIGN VALUES¹

CHARACTERISTIC	SYMBOL	UNITS	NOMINAL ANCHOR DIAMETER (inch)											
			1/2			5/8			3/4			1		
Anchor Category	1, 2 or 3	—	1			1			2			2		
Embedment Depth	h_{nom}	in.	2 ^{3/4}	3 ^{7/8}	5	3 ^{3/8}	5 ^{1/8}	6 ^{1/8}	4 ^{1/8}	5 ^{3/4}	7 ^{1/2}	5 ^{1/4}	9 ^{3/4}	
Steel Strength in Tension (ACI 318 Section D.5.1)														
Tension Resistance of Steel	N_{sa}	lbf	13,500			20,875			34,125			36,815		
Strength Reduction Factor—Steel Failure	ϕ_{sa}	—	0.75 ²			0.75 ²			0.65 ²			0.75 ²		
Concrete Breakout Strength in Tension (ACI 318 Section D.5.2)														
Effective Embedment Depth	h_{ef}	in.	2 ^{1/4}	3 ^{3/8}	4 ^{1/2}	2 ^{3/4}	4 ^{1/2}	5 ^{1/2}	3 ^{3/8}	5	6 ^{3/4}	4 1/2	9	
Critical Edge Distance	c_{ac}	in.	9	7 ^{7/8}	6 ^{3/4}	11	9 ^{5/8}	8 ^{1/4}	13 ^{1/2}	11 ^{3/4}	10 ^{1/8}	18	13 ^{1/2}	
Effectiveness Factor—Uncracked Concrete	k_{uncr}	—	24			24			24			24		
Effectiveness Factor—Cracked Concrete	k_{cr}	—	17			17			17			17		
Ratio of k_{uncr}/k_{cr}	$\chi_{c,N}$	—	1.41			1.41			1.41			1.41		
Strength Reduction Factor—Concrete Breakout Failure	ϕ_{cb}	—	0.65 ³			0.65 ³			0.55 ³			0.55 ³		
Pull-Out Strength in Tension (ACI 318 Section D.5.3)														
Pull-Out Resistance Cracked Concrete ($f'_c = 2,500$ psi)	$N_{pn,cr}$	lbf	N/A ⁴	2,995 ⁶	2,995 ⁶	N/A ⁴	5,200 ⁵	5,260 ⁵	N/A ⁴	N/A ⁴	9,850 ⁶	7,700 ⁶	11,185 ⁶	
Pull-Out Resistance Uncracked Concrete ($f'_c = 2,500$ psi)	$N_{pn,uncr}$	lbf	N/A ⁴	4,120 ⁶	4,600 ⁶	N/A ⁴	7,250 ⁵	7,300 ⁵	N/A ⁴	9,420 ⁶	12,115 ⁶	8,360 ⁶	9,690 ⁶	
Strength Reduction Factor—Pullout Failure	ϕ_p	—	0.65 ⁷			0.65 ⁷			0.55 ⁷			0.55 ⁷		
Tension Strength for Seismic Applications (ACI 318 Section D.3.3.3)														
Tension Resistance of Single Anchor for Seismic Loads ($f'_c = 2,500$ psi)	$N_{pn,eq}$	lbf	N/A ⁴	2,995 ⁶	2,995 ⁶	N/A ⁴	5,200 ⁵	5,260 ⁵	N/A ⁴	N/A ⁴	9,850 ⁶	7,700 ⁶	11,185 ⁶	
Strength Reduction Factor—Pullout Failure	ϕ_{eq}	—	0.65 ⁷			0.65 ⁷			0.55 ⁷			0.55 ⁷		

For SI: 1 inch = 25.4 mm, 1 lbf = 4.45 N.

¹The information presented in this table must be used in conjunction with the design criteria of ACI 318 Appendix D.

²The tabulated value of ϕ_{sa} applies when the load combinations of Section 1605.2.1 of the IBC, Section 1612.2.1 of the UBC, or ACI 318 Section 9.2 are used. If the load combinations of Section 1909.2 of the UBC or ACI 318 Appendix C are used, the appropriate value of ϕ_{sa} must be determined in accordance with ACI 318 D.4.5. The 1/2 inch, 5/8 inch, and 1 inch diameter anchors are ductile steel elements as defined in ACI 318 D.1. The 3/4 inch diameter anchor is a brittle steel element as defined in ACI 318 D.1.

³The tabulated value of ϕ_{cb} applies when both the load combinations of Section 1605.2.1 of the IBC, Section 1612.2.1 of the UBC, or ACI 318 Section 9.2 are used and the requirements of ACI 318 Section D.4.4(c) for Condition B are met. Condition B applies where supplementary reinforcement is not provided or where pullout strength governs. For installations where complying supplementary reinforcement can be verified, the ϕ_{cb} factors described in ACI 318 D.4.4 for Condition A are allowed. If the load combinations of Section 1909.2 of the UBC or ACI 318 Section 9.2 are used and the requirements of ACI 318 Section D.4.4 for Condition A are met, the appropriate value of ϕ_{cb} must be determined in accordance with ACI 318 D.4.4(c). If the load combinations of ACI 318 Appendix C are used, the appropriate value of ϕ_{cb} must be determined in accordance with ACI 318 D.4.5.

⁴As described in Section 4.1.3 of this report, N/A (Not Applicable) denotes that pullout resistance is not critical and does not need to be considered.

⁵The characteristic pull-out resistance for greater concrete compressive strengths may be increased by multiplying the tabular value by $(f'_c / 2,500)^{0.7}$.

⁶The characteristic pull-out resistance for greater concrete compressive strengths may be increased by multiplying the tabular value by $(f'_c / 2,500)^{0.5}$.

⁷The tabulated value of ϕ_p or ϕ_{eq} applies when both the load combinations of ACI 318 Section 9.2 are used and the requirements of ACI 318 D.4.4(c) for Condition B are met. Condition B applies where supplementary reinforcement is not provided or where pullout strength governs. For installations where complying supplementary reinforcement can be verified, the ϕ factors described in ACI 318 D.4.4 for Condition A are allowed. If the load combinations of ACI 318 Appendix C are used, appropriate value of ϕ must be determined in accordance with ACI 318 Section D.4.5.

TABLE 3—STRONG-BOLT™ CHARACTERISTIC SHEAR STRENGTH DESIGN VALUES¹

CHARACTERISTIC	SYMBOL	UNITS	NOMINAL ANCHOR DIAMETER (inch)										
			1/2		5/8		3/4		1				
Anchor Category	1, 2 or 3	—	1		1		2		2				
Embedment Depth	h_{nom}	in.	2 ³ / ₄	3 ⁷ / ₈	5	3 ³ / ₈	5 ¹ / ₈	6 ¹ / ₈	4 ¹ / ₈	5 ³ / ₄	7 ¹ / ₂	5 ¹ / ₄	9 ³ / ₄
Steel Strength in Shear (ACI 318 Section D.6.1)													
Shear Resistance of Steel	V_{sa}	lbf	6,560		10,475		19,305		15,020				
Strength Reduction Factor—Steel Failure	ϕ_{sa}	—	0.65 ²		0.65 ²		0.60 ²		0.65 ²				
Concrete Breakout Strength in Shear (ACI 318 Section D.6.2)													
Nominal Diameter	d_0	in.	0.5		0.625		0.75		1				
Load Bearing Length of Anchor in Shear	ℓ_e	in.	2.25	3.375	4.00	2.75	4.50	5.00	3.375	5.00	6.00	4.50	8
Strength Reduction Factor—Concrete Breakout Failure	ϕ_{cb}	—	0.70 ³										
Concrete Pryout Strength in Shear (ACI 318 Section D.6.3)													
Coefficient for Pryout Strength	k_{cp}	—	1.0		2.0								
Strength Reduction Factor—Concrete Pryout Failure	ϕ_{cp}	—	0.70 ⁴										
Shear Strength for Seismic Applications (ACI 318 Section D.3.3.3)													
Shear Resistance of Single Anchor for Seismic Loads ($f'_c = 2,500$ psi)	$V_{sa,eq}$	lbf	6,560		8,380	9,715	10,475	15,445	17,305	19,305	15,020		
Strength Reduction Factor—Steel Failure	ϕ_{eq}	—	0.65 ²		0.65 ²		0.60 ²		0.65 ²				

For **SI**: 1 inch = 25.4 mm, 1 lbf = 4.45 N.

¹The information presented in this table must be used in conjunction with the design criteria of ACI 318 Appendix D.

²The tabulated value of ϕ_{sa} applies when the load combinations of Section 1605.2.1 of the IBC, Section 1612.2.1 of the UBC, or ACI 318 Section 9.2 are used and the requirements of ACI 318 D.4.4(c) for Condition B are met. If the load combinations of Section 1909.2 of the UBC or ACI 318 Appendix C are used, the appropriate value of ϕ_{sa} must be determined in accordance with ACI 318 D.4.5. The 1/2 inch, 5/8 inch, and 1 inch diameter anchors are ductile steel elements as defined in ACI 318 D.1.1. The 3/4 inch diameter anchor is a brittle steel element as defined in ACI 318 Section D.1.

³The tabulated value of ϕ_{cb} applies when both the load combinations of Section 1605.2.1 of the IBC, Section 1612.2.1 of the UBC, or ACI 318 Section 9.2 are used and the requirements of ACI 318 Section D.4.4(c) for Condition B are met. Condition B applies where supplementary reinforcement is not provided or where pryout strength governs. For installations where complying supplementary reinforcement can be verified, the ϕ factors described in ACI 318 Section D.4.4 for Condition A are allowed. If the load combinations of Section 1909.2 of the UBC or ACI 318 Section 9.2 are used and the requirements of ACI 318 Section D.4.4 for Condition A are met, the appropriate value of ϕ must be determined in accordance with ACI 318 Section D.4.4(c). If the load combinations of ACI 318 Appendix C are used, the appropriate value of ϕ must be determined in accordance with ACI 318 Section D.4.5.

⁴The tabulated value of ϕ_{cp} applies when both the load combinations of ACI 318 Section 9.2 are used and the requirements of ACI 318 D.4.4(c) for Condition B are met. Condition B applies where supplementary reinforcement is not provided or where pryout strength governs. For installations where complying supplementary reinforcement can be verified, the ϕ factors described in ACI 318 Section D.4.4 for Condition A are allowed. If the load combinations of ACI 318 Appendix C are used, the appropriate value of ϕ must be determined in accordance with ACI 318 D.4.5.

TABLE 4—STRONG-BOLT™ CHARACTERISTIC TENSION AND SHEAR STRENGTH DESIGN VALUES FOR THE SOFFIT OF CONCRETE-FILLED PROFILE STEEL DECK ASSEMBLIES^{1,2,7}

CHARACTERISTIC	SYMBOL	UNITS	NOMINAL ANCHOR DIAMETER (inch)			
			1/2		5/8	
Embedment Depth	h_{nom}	in.	2 ³ / ₄	4 ¹ / ₂	3 ³ / ₈	5 ⁵ / ₈
Effective Embedment Depth	h_{ef}	in.	2 ¹ / ₄	4	2 ³ / ₄	5
Installation Torque	T_{inst}	ft-lbf	40	40	40	50
Pull-Out Resistance Cracked Concrete ³	$N_{pn,deck,cr}$	lbf	1,335 ⁶	1,905	2,835	3,665
Pull-Out Resistance Uncracked Concrete ⁴	$N_{pn,deck,uncr}$	lbf	1,830 ⁶	2,610	3,780	4,885
Steel Strength in Shear ⁵	$V_{st,deck}$	lbf	4,405 ⁶	6,690	6,270	8,865

For **SI**: 1 inch = 25.4 mm, 1 ft-lbf = 1.356 N-m, 1 lbf = 4.45 N.

¹Installation must comply with Section 4.3 and Figure 3. Except as specifically noted, all installations must be into the lower flute of the deck.

²Profile steel deck must comply with Figure 3 and have a minimum base steel thickness of 0.034 inch. Steel must comply ASTM A 653 / A 653M, with minimum yield strength of 40 ksi (276 MPa).

³The values must be used in accordance with Section 4.1.3 and 4.1.7.2 of this report.

⁴The values must be used in accordance with Section 4.1.3 of this report.

⁵The values must be used in accordance with Section 4.1.4 and 4.1.7.3 of this report.

⁶Anchors may be installed into either the upper or lower flute of the steel deck.

⁷The minimum anchor spacing along the flute must be the greater of 3.0 h_{ef} or 1.5 times the flute width.

**TABLE 5— EXAMPLE STRONG-BOLT™ ALLOWABLE STRESS DESIGN
TENSION VALUES FOR ILLUSTRATIVE PURPOSES** ^{1,2,3,4,5,6,7,8,9}

Nominal Anchor Diameter (in.)	Embed. Depth (in.)	Effective Embed. Depth, h_{ef} (in.)	Allowable Tension Load, $\phi N_r/\alpha$ (lbs.)
1/2	2 3/4	2 1/4	1,775
	3 7/8	3 3/8	1,810
	5	4 1/2	2,020*
5/8	3 3/8	2 3/4	2,400
	5 1/8	4 1/2	3,185
	6 1/8	5 1/2	3,205
3/4	4 1/8	3 3/8	2,760
	5 3/4	5	3,500
	7 1/2	6 3/4	4,500
1	5 1/4	4 1/2	3,110
	9 3/4	9	3,600

Design Assumptions:

¹Single anchor.

²Tension load only.

³Concrete determined to remain uncracked for the life of the anchorage.

⁴Load combinations taken from ACI 318 Section 9.2 (no seismic loading).

⁵30 percent Dead Load (D) and 70 percent Live Load (L); Controlling load combination is $1.2D + 1.6L$. Calculation of α based on weighted average: $\alpha = 1.2D + 1.6L = 1.2(0.3) + 1.6(0.7) = 1.48$

⁶Normal weight concrete with $f'_c = 2,500$ psi

⁷ $C_{a1} = C_{a2} \geq C_{ac}$

⁸ $h \geq h_{min}$

⁹Values are for Condition B (supplementary reinforcement in accordance with ACI 318 D.4.4 is not provided.)

* Illustrative Procedure (reference Table 2 of this report):

Strong-Bolt™ 1/2 inch (12.7 mm) diameter with an effective embedment, $h_{ef} = 4 1/2$ "

Step 1: Calculate steel strength in tension in accordance with ACI 318 D.5.1;

$$\phi_{sa} N_{sa} = 0.75 \times 13,500 = 10,125 \text{ lbs.}$$

Step 2: Calculate concrete breakout strength in tension in accordance with ACI 318 D.5.2; $\phi_{cb} N_{cb} = 0.65 \times 11,440 = 7,435$ lbs.

Step 3: Calculate pullout strength in tension per ACI 318 D.5.3; $\phi_p N_{pn,uncr} = 0.65 \times 4,600 = 2,990$ lbs.

Step 4: The controlling value (from Steps 1, 2, and 3 above) in accordance with ACI 318 D.4.1.2; $\phi N_n = 2,990$ lbs.

Step 5: Divide the controlling value by the conversion factor α as determined in footnote 5 and in accordance with Section 4.2.1 of this report: $T_{allowable,ASD} = \phi N_n / \alpha = 2,990 / 1.48 = 2,020$ lbs.

For single anchor and anchor groups, the edge distance, spacing and member thickness requirements in Table 1 of this report apply.

TABLE 6—STRONG-BOLT™ LENGTH IDENTIFICATION CODES

Length Identification Head Marks on Strong-Bolt Anchors (corresponds to length of anchor – inches).

Mark	A	B	C	D	E	F	G	H	I	J	K	L	M	N	O	P	Q	R	S	T	U	V	W	X	Y	Z
From	1½	2	2½	3	3½	4	4½	5	5½	6	6½	7	7½	8	8½	9	9½	10	11	12	13	14	15	16	17	18
Up To But Not Including	2	2½	3	3½	4	4½	5	5½	6	6½	7	7½	8	8½	9	9½	10	11	12	13	14	15	16	17	18	19

For SI: 1 inch = 25.4 mm.



FIGURE 1—STRONG-BOLT™ WEDGE ANCHOR

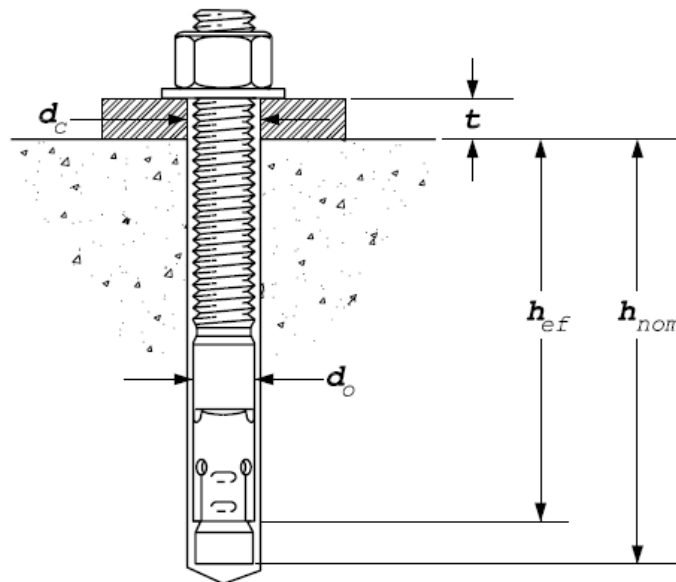

FIGURE 2—STRONG-BOLT™ WEDGE ANCHOR INSTALLATION

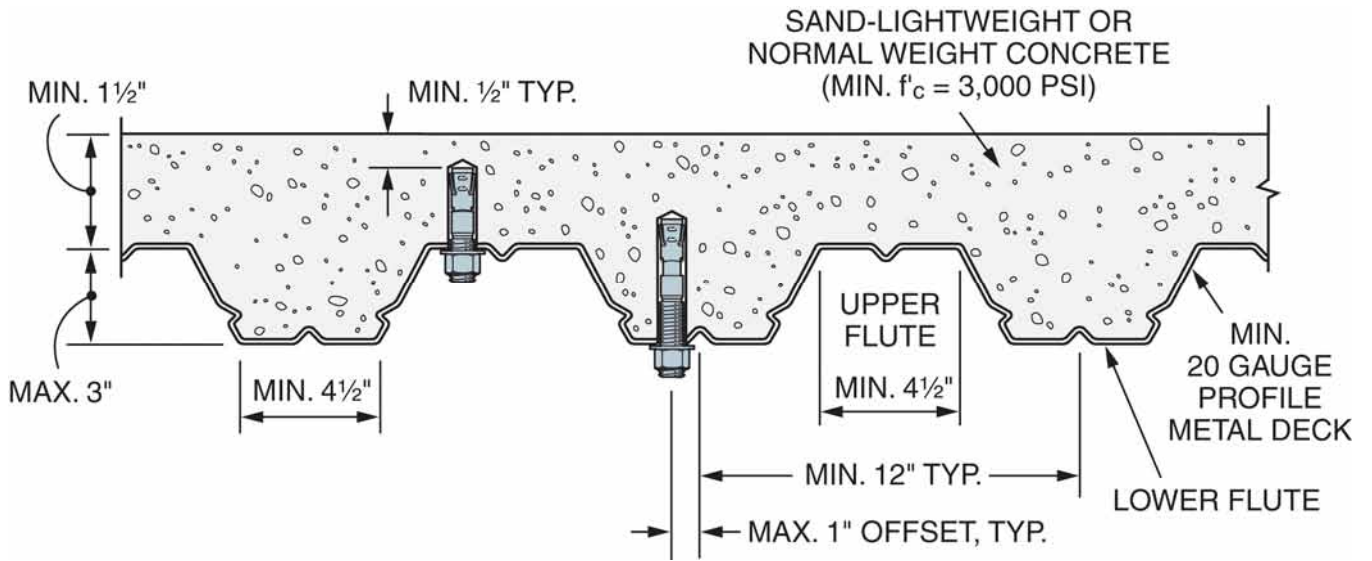
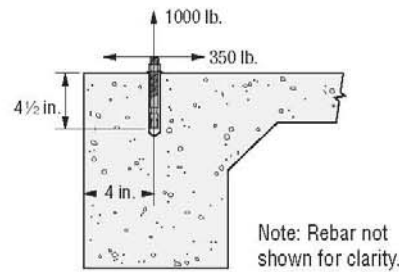

FIGURE 3—INSTALLATION IN THE SOFFIT OF CONCRETE OVER PROFILE STEEL DECK FLOOR AND ROOF ASSEMBLIES

Determine if a single ½ inch diameter Strong-Bolt™ torque-controlled expansion anchor with a minimum 5 inch embedment ($h_{ef} = 4\frac{1}{2}$ inches) installed 4 inches from the edge of a 12 inch deep spandrel beam is adequate for a service tension load of 1,000 lb. for wind and a reversible service shear load of 350 lb. for wind. The anchor will be in the tension zone, away from other anchors in $f'_c = 3,000$ psi normal-weight concrete.



	ACI 318-05 Code Ref.	Report Ref.
1. Determine the Factored Tension and Shear Design Loads:	9.2.1	
$N_{ua} = 1.6W = 1.6 \times 1,000 = 1,600$ lb.		
$V_{ua} = 1.6W = 1.6 \times 350 = 560$ lb.		
2. Steel Capacity under Tension Loading:	D.5.1	
$N_{sa} = 13,500$		Table 2
$\phi = 0.75$		Table 2
$n = 1$ (single anchor)		
Calculating for ϕN_{sa} :		
$\phi N_{sa} = 0.75 \times 1 \times 13,500 = 10,125$ lb.		
3. Concrete Breakout Capacity under Tension Loading:	D.5.2	
$N_{cb} = \frac{A_{Nc}}{A_{Nco}} \psi_{ed,N} \psi_{c,N} \psi_{cp,N} N_b$	Eq. (D-4);	
where:		
$N_b = k_c \sqrt{f'_c} h_{ef}^{1.5}$	Eq. (D-7)	
substituting:		
$\phi N_{cb} = \phi \frac{A_{Nc}}{A_{Nco}} \psi_{ed,N} \psi_{c,N} \psi_{cp,N} k_c \sqrt{f'_c} h_{ef}^{1.5}$		
where:		Table 2
$k_c = k_{cr} = 17$		
$\psi_{cp,N} = 1.0$	D.5.2.7	
$\psi_{ed,N} = 0.7 + 0.3 \frac{c_{a,min}}{1.5h_{ef}}$ when $c_{a,min} < 1.5 h_{ef}$	Eq. (D-11)	
by observation, $c_{a,min} = 4 < 1.5h_{ef}$		
$\psi_{ed,N} = 0.7 + 0.3 \frac{(4)}{1.5(4.5)} = 0.88$		
$\psi_{c,N} = 1.0$ assuming cracking at service loads ($f_t > f_r$)	D.5.2.6	
$\phi = 0.65$ for Condition B (no supplementary reinforcement provided)		Table 2
$A_{Nco} = 9h_{ef}^2 = 9(4.5)^2 = 182.25$ in. ²	Eq. (D-6)	
$A_{Nc} = (c_{a1} + 1.5h_{ef})(2 \times 1.5h_{ef}) = (4 + 1.5(4.5))(2 \times 1.5(4.5)) = 145.13$ in. ²	Fig. RD.5.2.1(a)	
$\frac{A_{Nc}}{A_{Nco}} = \frac{145.13}{182.25} = 0.8$		
Calculating for ϕN_{cb} :		
$\phi N_{cb} = 0.65 \times 0.8 \times 1.0 \times 0.88 \times 1.0 \times 17 \times \sqrt{3,000} \times (4.5)^{1.5} = 4,067$ lb.		

	ACI 318-05 Code Ref.	Report Ref.
4. Pullout Capacity:	D.5.3	
$N_{pn,cr} = 2,995 \times \left(\frac{3,000}{2,500}\right)^{0.5} = 3,281$ lb.		Table 2
$\phi = 0.65$		Table 2
$\phi N_{pn} = 0.65 \times 3,281 = 2,133$.		
5. Check All Failure Modes under Tension Loading:	D.4.1.2	
Summary:		
Steel Capacity = 10,125 lb.		
Concrete Breakout Capacity = 4,067 lb.		
Pullout Capacity = 2,133 lb. ← Controls		
$\therefore \phi N_n = 2,133$ lb. as Pullout Capacity controls $> N_{ua} = 1,600$ lb. – OK		
6. Steel Capacity under Shear Loading:	D.6.1	
$V_{sa} = 5,560$ lb.		Table 3
$\phi = 0.65$		Table 3
Calculating for ϕV_{sa} :		
$\phi V_{sa} = 0.65 \times 5,560 = 4,264$ lb.		
7. Concrete breakout Capacity under Shear Loading:	D.6.2	
$V_{cb} = \frac{A_{Vc}}{A_{Vco}} \psi_{ed,V} \psi_{c,V} V_b$	Eq. (D-21)	
where:		
$V_b = 7 \left(\frac{\ell_b}{d_o}\right)^{0.2} \sqrt{d_o} \sqrt{f'_c} c_{a1}^{1.5}$	Eq. (D-24)	
substituting:		
$\phi V_{cb} = \phi \frac{A_{Vc}}{A_{Vco}} \psi_{ed,V} \psi_{c,V} 7 \left(\frac{\ell_b}{d_o}\right)^{0.2} \sqrt{d_o} \sqrt{f'_c} c_{a1}^{1.5}$		
where:		Table 3
$\phi = 0.70$ for Condition B (no supplementary reinforcement provided)		
$A_{Vco} = 4.5c_{a1}^2 = 4.5(4)^2 = 72$ in. ²	Eq. (D-23)	
$A_{Vc} = 2(1.5c_{a1})(1.5c_{a1}) = 2(1.5(4))(1.5(4)) = 72$ in. ²	Fig. RD.6.2.1(a)	
$\frac{A_{Vc}}{A_{Vco}} = \frac{72}{72} = 1$	D.6.2.1	
$\psi_{ed,V} = 1.0$ since $c_{a2} > 1.5c_{a1}$	Eq. (D-27)	
$\psi_{c,V} = 1.0$ assuming cracking at service loads ($f_t > f_r$)	D.6.2.7	
$d_o = 0.5$ in.		
$\ell_b = 8d_o = 8(0.5) = 4$ in.	D.6.2.2	
$c_{a1} = 4$ in.		
$\phi V_{cb} = 0.70 \times 1 \times 1.0 \times 1.0 \times 7 \times \left(\frac{4}{0.5}\right)^{0.2} \times \sqrt{0.5} \times \sqrt{3,000} \times (4)^{1.5} = 2,301$ lb.		

FIGURE 4—STRONG BOLT™ EXAMPLE CALCULATION

	ACI 318-05 Code Ref.	Report Ref.		ACI 318-05 Code Ref.	Report Ref.
8. Concrete Pryout Strength:	<i>D.6.3</i>			<i>D.7</i>	
$V_{cp} = k_{cp} N_{cb}$	<i>Eq. (D-29)</i>				
where:					
$n = 1$					
$\phi = 0.70$		<i>Table 3</i>			
$k_{cp} = 2.0$	<i>D.6.3.1</i>				
$k_{cp} N_{cb} = 2.0 \times \frac{4,067}{0.65} = 12,514 \text{ lb.}$	<i>D.6.3.1</i>				
$\phi n V_{cp} = 0.70 \times 1 \times 12,514 = 8,760 \text{ lb.}$					
9. Check All Failure Modes under Shear Loading:	<i>D.4.1.2</i>				
Summary:					
Steel Capacity = 4,264 lb.					
Concrete Breakout Capacity = 2,301 lb. ← Controls					
Pryout Capacity = 8,760 lb.					
∴ $\phi V_n = 2,301 \text{ lb. as Concrete Breakout Capacity controls}$					
					$V_{ua} = 560 \text{ lb. - OK}$
			10. Check Interaction of Tension and Shear Forces:	<i>D.7</i>	
			If $0.2 \phi V_n \geq V_{ua}$, then the full tension design strength is permitted.	<i>D.7.1</i>	
			By observation, this is not the case.		
			If $0.2 \phi N_n \geq N_{ua}$, then the full shear design strength is permitted	<i>D.7.2</i>	
			By observation, this is not the case.		
			Therefore:		
			$\frac{N_{ua}}{\phi N_n} + \frac{V_{ua}}{\phi V_n} \leq 1.2$	<i>Eq. (D-31)</i>	
			$\frac{1,600}{2,133} + \frac{560}{2,301} = 0.75 + 0.24 = 0.99 < 1.2 - \text{OK}$		
			11. Summary		
			A single ½ in. diameter Strong-Bolt™ anchor at a 5 in. embedment depth is adequate to resist the applied service tension and shear loads of 1,000 lb. and 350 lb., respectively.		

FIGURE 4—STRONG BOLT™ EXAMPLE CALCULATION (Continued)