

ICC-ES Evaluation Report

ESR-1849
Issued January 1, 2009
This report is subject to re-examination in one year.
www.icc-es.org | (800) 423-6587 | (562) 699-0543

A Subsidiary of the International Code Council®

DIVISION: 06—WOOD AND PLASTICS
Section: 06500—Structural Plastics
Section: 06610—Plastic Railings and Guards

REPORT HOLDER:

RAILING DYNAMICS, INC.
 135 STEELMANVILLE ROAD
 EGG HARBOR TOWNSHIP, NEW JERSEY 08234
 (609) 601-1300
www.rdirail.com

EVALUATION SUBJECT:
ENDURANCE® RAILING SYSTEM
1.0 EVALUATION SCOPE
Compliance with the following codes:

- 2006 *International Building Code*® (IBC)
- 2006 *International Residential Code*® (IRC)

Properties evaluated:

- Structural
- Durability
- Surface-burning characteristics

2.0 USES

The Endurance® Railing System described in this report is limited to exterior use as guards for balconies, porches, and decks. The products described in this report are used in exterior applications in buildings of Type V-B (IBC) construction and other types of construction in applications where untreated wood is permitted by IBC Section 1406.3, or in buildings constructed in accordance with the IRC.

3.0 DESCRIPTION
3.1 General:

The Endurance® Railing System consists of 100 percent polyvinyl chloride (PVC) railing components and aluminum reinforcement members for the top and bottom hollow rails. The PVC railing components are white in color and are manufactured by an extrusion process in accordance with the approved quality control documentation.

The Endurance® Railing System is a guard consisting of top rails, bottom rails, balusters, nonstructural post sleeves and caps, rail-to-post connector brackets, aluminum pin connectors, and aluminum top and bottom reinforcing

components. The top stiffener is made from aluminum alloy 6105-T5; the bottom stiffener is made from aluminum alloy 6063-T6. The minimum yield and tensile strengths, and minimum thickness, of the aluminum inserts are specified in the approved quality control documentation. Each rail is attached to structural posts using PVC brackets with stainless steel post attachment screws and aluminum rail pin connectors. Turned or square PVC balusters are used as infill of the railing system.

3.2 Guards:

The height of the railing assembly is 36 inches or 42 inches (914 or 1067 mm) above the walking surface. Each post is covered with a 4-inch-by-4-inch (102 mm by 102 mm) PVC sleeve. The top rail has a T-shape and is 3¹/₄ inches (82 mm) wide at the top and 1³/₄ inches (44.45 mm) wide at the bottom, and has a total depth of 1³/₄ inches (44.45 mm) and a wall thickness of 0.085 inch (2.16 mm). The rectangular bottom rail is 1³/₄ inches (44.45 mm) wide at top and bottom, and has a depth of 3¹/₂ inches (88.9 mm) and a wall thickness of 0.105 inch (2.67 mm). Both top and bottom rails are available in 4-foot, 5-foot, 6-foot and 8-foot (1.22, 1.52, 1.83 and 2.44 m) lengths.

The balusters are hollow, blow-molded spindles as well as square extruded hollow pickets. The spindles are 1¹/₄ inches (31.75 mm) square at the top and bottom. The pickets are 1¹/₄ inches (31.75 mm) square, and have a wall thickness of 0.08 inch (2.03 mm). When the pickets are installed in the rails, there is a clear space of less than 4 inches (102 mm) between pickets.

The post sleeves are 4 inches (102 mm) square and have a wall thickness of 0.08 inch (2.03 mm). See Figure 3 for dimensioned profiles of the post sleeves, top and bottom rails, top and/or bottom rail aluminum inserts, and balusters. The mounting brackets are made from molded plastic.

3.3 Durability:

When subjected to weathering, insect attack, and other decaying elements, the material used to manufacture the Endurance® Railing System is equivalent in durability to code-complying, preservative-treated or naturally durable lumber when used in locations described in Section 2.0. The Endurance® Railing System has been evaluated for structural performance when exposed to temperatures from -20°F (-29°C) to 125°F (52°C).

3.4 Surface-burning Characteristics:

When tested in accordance with ASTM E 84, the Endurance® Railing System has a flame-spread index of no greater than 200.

4.0 DESIGN AND INSTALLATION

4.1 General:

The Endurance® Railing System must be installed in accordance with the manufacturer's published installation instructions, the approved construction documents and this report. The manufacturer's published installation instructions must be available at all times on the jobsite during installation.

4.2 Design:

The Endurance® Railing System is satisfactory to resist the loads specified in Section 1607.7.1 of the IBC and Table R301.5 of the IRC, when installed at a maximum 8-foot (2.44 m) edge-of-post to edge-of-post spacing. When the railing is supported on one or both ends by the supporting construction, the maximum distance must be measured from edge-of-post to edge-of-structure or from edge-of-structure to edge-of-structure. See Table 1.

4.3 Installation:

The top and bottom aluminum reinforced rails are slid into their respective rail-to-post connector brackets. The bottom aluminum reinforcing component is to be installed with the top leg of the component facing the outside of the structure. The top and bottom rail-to-post connector brackets are attached to wood vertical posts or to other supporting construction, such as an exterior wall. Vertical wood posts are covered with nonstructural PVC post caps. The top rail-to-post connector bracket is secured with two No. 10 by 2-inch (51 mm) stainless steel wood screws for connections to solid sawn lumber with a minimum specific gravity of 0.42. The bottom rail-to-post connector bracket is secured with four No. 10 by 2-inch (51 mm) stainless steel wood screws. The balusters are installed by inserting each one into prerouted holes in both the top and bottom rails. There are two balusters in each assembly that have crimped ends. These two balusters are to be spaced evenly within the assembly. Vertical supports (posts) for the Endurance® Railing System are outside the scope of this report and must be designed to resist horizontal and vertical loads on the guard as specified in the applicable code. See Figure 1 for top rail assembly detail.

5.0 CONDITIONS OF USE

The Endurance® Railing System described in this report complies with, or is a suitable alternative to what is specified in, those codes listed in Section 1.0 of this report, subject to the following conditions:

- 5.1 This product is limited to exterior use as a guardrail system for balconies, porches and decks in buildings of Type V-B (IBC) construction and other types of

construction in applications where untreated wood is permitted by IBC Section 1406.3, or in buildings constructed in accordance with the IRC.

- 5.2 Installation must comply with this report, the manufacturer's published installation instructions and the applicable code. When the manufacturer's published installation instructions differ from this report, this report governs.
- 5.3 Only those fasteners and fastener configurations described in this report have been evaluated for the installation of the Endurance® Railing System. The compatibility of the fasteners with the supporting construction, including chemically treated wood, is outside the scope of this report.
- 5.4 The Endurance® Railing System must be directly fastened to supporting construction having adequate strength and stiffness. Where required by the code official, engineering calculations and construction documents consistent with this report must be submitted for approval. The calculations must verify that the supporting construction complies with the applicable building code requirements and is adequate to resist the loads imparted upon it from the products and systems discussed in this report. The documents must contain details of the attachment to the supporting structure consistent with the requirements of this report. The documents must be prepared by a registered design professional where required by the statutes of the jurisdiction in which the project is to be constructed.
- 5.5 The use of wood posts, with or without post sleeves, is outside the scope of this report.
- 5.6 The use of a corner rail connection that is connected to a rail post is outside the scope of this report.
- 5.7 The Endurance® Railing System is produced in Millville, New Jersey, under a quality control program with inspections by PFS Corporation. (AA-652).

6.0 EVIDENCE SUBMITTED

Data in accordance with the ICC-ES Acceptance Criteria for Deck Board Span Ratings and Guardrail Systems (Guards and Handrails) (AC174), dated February 2007.

7.0 IDENTIFICATION

The Endurance® Railing System described in this report is identified by a stamp, on each individual piece or on the packaging, bearing the manufacturer's name (Railing Dynamics, Inc.), the product name (Endurance® Railing System), the name of the inspection agency (PFS), and the ICC-ES evaluation report number (ESR-1849).

TABLE 1—MAXIMUM GUARDRAIL SYSTEM SPANS¹

PRODUCT NAME/COMPONENT	APPLICABLE BUILDING CODE ^{2,5}		MAXIMUM SPAN 3, 4 (ft-in)
	IBC	IRC	
Endurance [®] Railing System with Square Balusters	Yes	Yes	8-0
Endurance [®] Railing System with Turned Balusters	Yes	Yes	8-0

For SI: 1 inch = 25.4 mm; 1 ft = 305 mm.

¹The ability of the supporting construction to resist the reactionary loads must be justified to the satisfaction of the code official.

²Indicates compliance with the respective building codes.

³Maximum span is measured from edge-of-post to edge-of-post, edge-of-post to edge-of-structure or edge-of-structure to edge-of-structure.

⁴Maximum allowable span has been adjusted for durability. No further increases are permitted.

⁵The minimum height of the top rail is 42 inches for the IBC (Section 1013.2) and 36 inches for the IRC (Section R312).

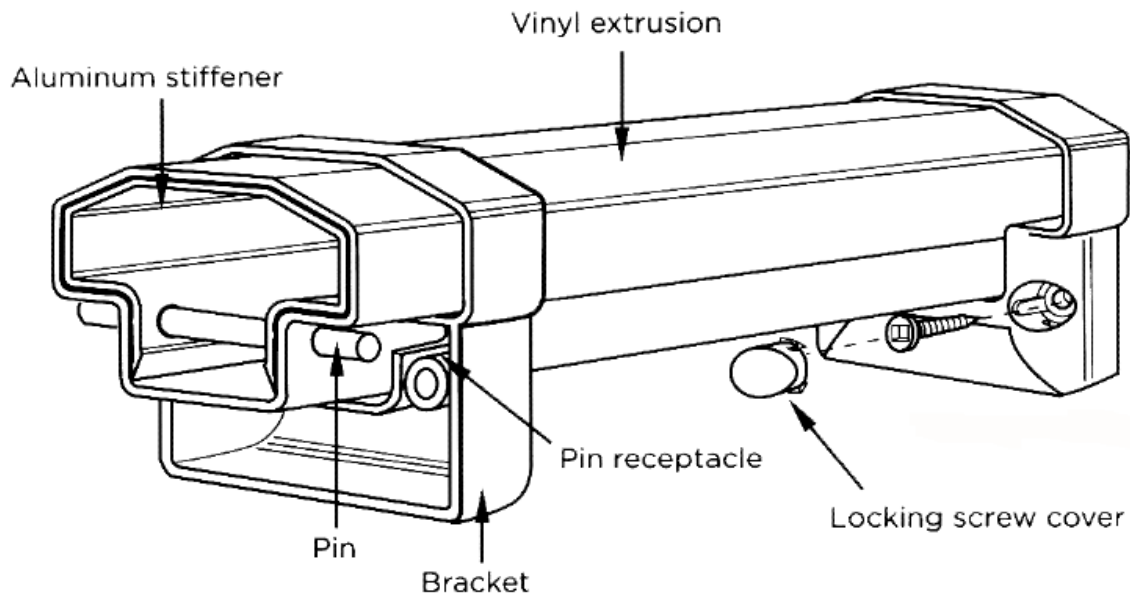

FIGURE 1—TOP RAIL MOUNTING ASSEMBLY

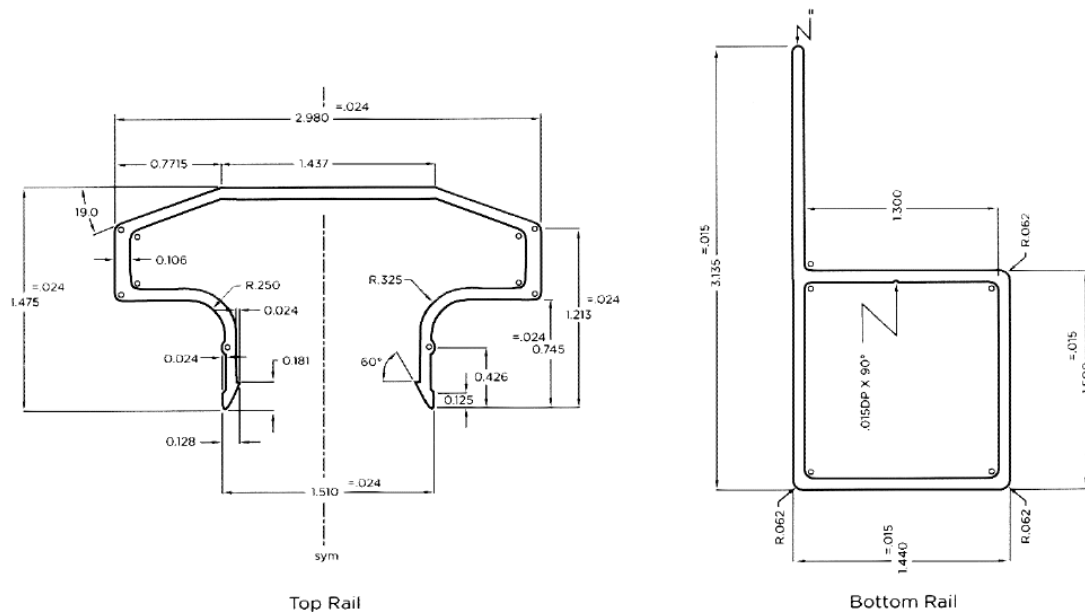

FIGURE 2—ALUMINUM TOP AND BOTTOM RAIL INSERTS

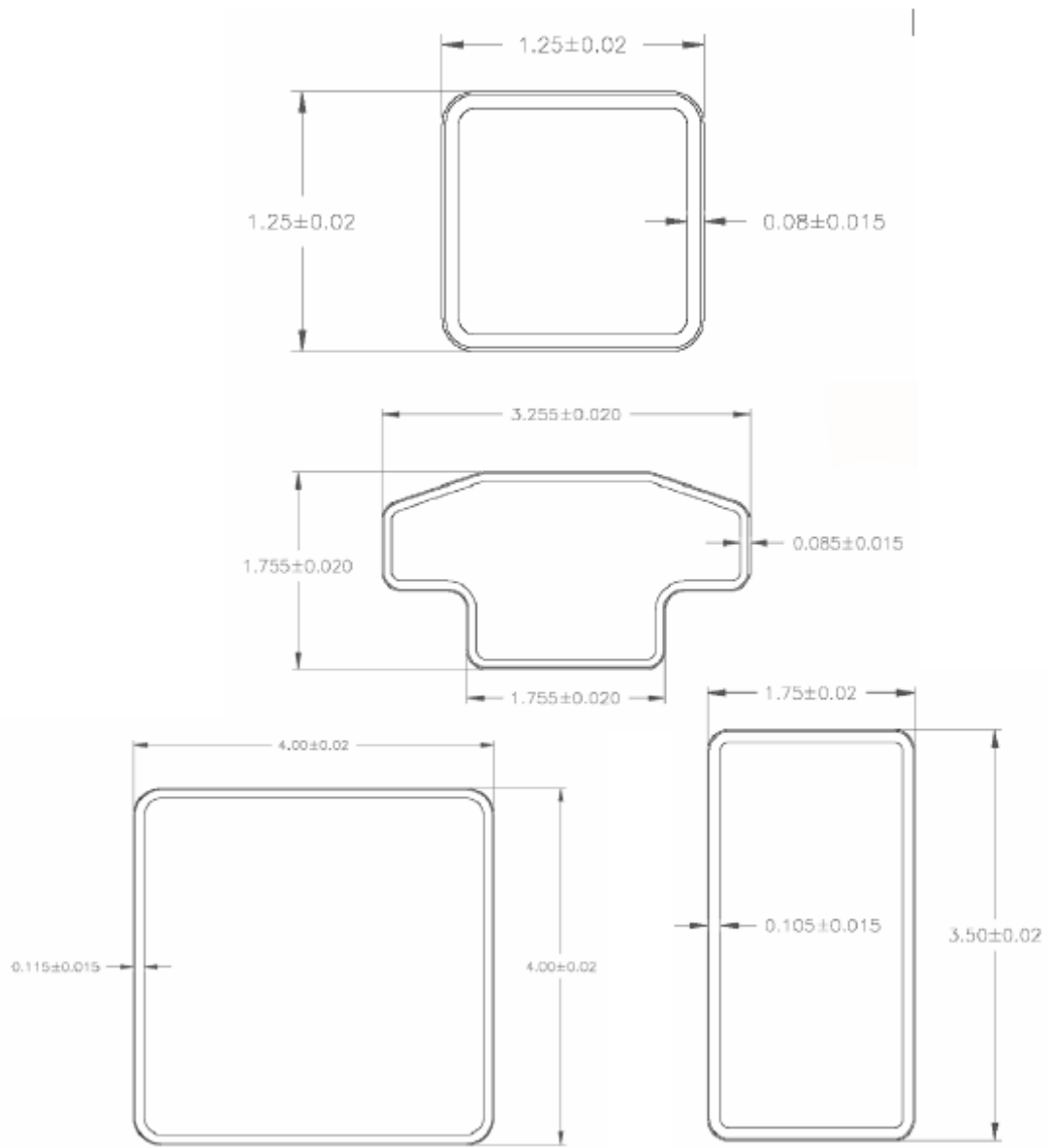

FIGURE 3—PLASTIC PROFILES OF TOP AND BOTTOM RAIL POST SLEEVE AND BALUSTER (dimensions in inches)