

# ICC-ES Evaluation Report

## ESR-1991

Reissued June 1, 2009

This report is subject to re-examination in one year.

[www.icc-es.org](http://www.icc-es.org) | (800) 423-6587 | (562) 699-0543

A Subsidiary of the International Code Council®

**DIVISION: 06—WOOD AND PLASTICS**  
**Section: 06170—Prefabricated Structural Wood**

### REPORT HOLDER:

**STANDARD STRUCTURES INC.**  
5900 PRUITT AVENUE  
WINDSOR, CALIFORNIA 95492-8767  
(707) 836-8191  
[www.standardstructures.com](http://www.standardstructures.com)  
[steve@standardstructures.com](mailto:steve@standardstructures.com)

### EVALUATION SUBJECT

#### SSI WOOD I-JOISTS

#### 1.0 EVALUATION SCOPE

##### Compliance with the following codes:

- 2006 *International Building Code*® (IBC)
- 2006 *International Residential Code*® (IRC)

##### Properties evaluated

- Structural
- Fire resistance

#### 2.0 USES

SSI Wood I-joists are used as floor joists and roof rafters to support code-specified loads.

#### 3.0 DESCRIPTION

##### 3.1 General:

SSI Wood I-joists are structural elements that comply with Section 2303.1.2 of the IBC and Section R502.1.4 of the IRC. The I-joists are manufactured with MSR or LVL flanges, and oriented strand board (OSB) webs. The lumber flanges and wood structural panel webs are bonded together with adhesive to form an I-shaped cross section with a constant or single-tapered depth, and are available in sections ranging from 9.5 inches (241 mm) to 30 inches (762 mm) deep. The SSI I-joists are manufactured in accordance with the requirements of ASTM D 5055 in accordance with Section 2303.1.2 of the IBC.

##### 3.2 Material:

**3.2.1 Flanges:** The flanges are machine-stress-rated (MSR) lumber or laminated-veneer lumber (LVL). The assigned allowable tension stresses for the MSR flanges are verified in accordance with the procedures set forth in

the approved Standard Structures quality control and procedures manual. The MSR lumber is finger jointed in accordance with the specifications in the quality control and procedures manual, and the maximum moisture content at time of fabrication is 16 percent. The LVL flange material complies with the approved Standard Structures quality control and procedures manual. The flanges are available in the following nominal width-by-depth designations: 2-by-2, 3-by-2, 4-by-2, 4-by-3, and 4-by-4. The actual flange dimensions are given in Tables 2A and 2B.

SSI I-joist model nomenclature differentiates the I-joists by type of flange using a suffix beginning with an "M..." for MSR flanges (e.g., SSI 42MXH), and beginning with an "L..." for LVL flanges (e.g., SSI 32L). Design values for each SSI I-joist model are given in Tables 2A, 2B, and 2C. An additional letter "r" is included in the suffix (e.g., SSI 43Lr and SSI 42MXH<sub>r</sub>) when the top flange is reinforced with plywood or OSB as described in Section 3.2.1.1.

**3.2.1.1 Top Flange Reinforcement (R-chord):** The reinforcement material is a strip of Exposure 1, rated plywood or OSB complying with DOC PS-1 or DOC PS-2, as applicable, <sup>3</sup>/<sub>8</sub> inch to <sup>1</sup>/<sub>2</sub> inch thick (9.5 to 12.7 mm), factory-adhered to the upper surface of the top flange. The strip covers the full width of the top flange for the entire length of the joist. The reinforcement is used in I-joist applications to prevent splitting of the flange caused by the installation of large-diameter or closely spaced nails. The reinforcement thickness is part of the nominal joist depth but is not included in the I-joist section properties used in design. The shear, moment, and EI values in Tables 2A and 2B must be reduced by the multiplication factors in Table 4 when top-flange reinforcement is used. Top flange reinforcement is not used with the I-joists in Table 2C.

**3.2.2 Web:** Webs are <sup>3</sup>/<sub>8</sub>-, <sup>7</sup>/<sub>16</sub>-, or <sup>1</sup>/<sub>2</sub>-inch-thick (9.5 mm, 11.1 mm, or 12.7 mm) OSB, Exposure 1, conforming to U.S. DOC Product Standard PS-2. Web-to-web joints are glued to form a continuous web member.

**3.2.3 Adhesive:** Adhesives used in the SSI I-joist manufacturing process conform to the requirements of ASTM D 2559, are tested in accordance with ASTM D 7247, and meet the heat durability requirements of ASTM D 5055-08a.

#### 4.0 DESIGN AND INSTALLATION

Installation of SSI I-joists must comply with this report and the manufacturer's published installation instructions. The manufacturer's published installation instructions must be available at the jobsite at all times during installation.

#### 4.1 General:

Allowable design values are as indicated in Tables 2A, 2B and 2C. Design of members for individual jobs must be based on allowable stress design, using the reference design shear, reaction, and bending moment values noted in Tables 2A, 2B, and 2C. Design values for intermediate depths are permitted to be interpolated. The design shear must not exceed the maximum allowable vertical shear at the support. In Table 2A the value noted for the 2<sup>1</sup>/<sub>2</sub>-inch (64 mm) bearing with stiffeners corresponds to the allowable vertical shear. The SSI I-joists listed in Table 2B must have a minimum bearing length of 2<sup>1</sup>/<sub>2</sub> inches (64 mm), except that a minimum bearing length of 1<sup>3</sup>/<sub>4</sub> inches (44 mm) is permitted for all joists listed in Table 2B up to a maximum depth of 20 inches (508 mm). The webs of simple-span, uniformly loaded I-joists having flanges with minimum nominal dimensions of 2-by-2 (38.1 mm by 41.3 mm) are permitted to have holes as indicated in Figure 1. The SSI Joists listed in this report may be installed in simple span, multiple span, or cantilever applications.

#### 4.2 Tapered Profile SSI Wood I-Joists:

Tapered SSI I-joists are designed with interpolated properties from Tables 2A and 2B, with consideration of maximum strength requirements at all depth increments. Analysis of the allowable hole size must consider distance from support and depth of joist at the desired hole location.

#### 4.3 Allowable Capacity:

Allowable moments, vertical shear forces, stiffness (EI), and end reactions, with and without stiffeners, are given in Tables 2A, 2B, and 2C for each SSI I-joist model. Moment Capacity of the SSI Wood I-joists must not be increased by any repetitive member use factor.

#### 4.4 Lateral Support:

The compression flange of the I-joist must be laterally supported throughout its length to prevent lateral displacement. I-joist ends must be restrained to prevent rollover, by diaphragm sheathing attached to the top flange and to an end wall or shear transfer panel, or blocking or cross-bracing capable of transferring the larger of 50 pounds per foot (730 N/m) or the required shear force due to wind, seismic, or soil conditions. Bridging is not required in SSI wood I-joist floor and roof joist applications.

**4.4.1 Lateral Load Capacity Hangers:** Model TGLT hangers manufactured by Tobin Steel Company and described in Table 3, may be used to support the ends of nominally 4-inch-thick-by-4-inch-wide (88.9 mm by 76.2 mm) SSI I-joists, and to connect the joists to their supporting construction. The hangers are of ASTM A 36 steel, with minimum yield strength,  $F_y$ , of 36 ksi (248 MPa) and a minimum tensile strength,  $F_t$ , of 58 ksi (400 MPa). Web stiffeners must be installed at the hanger-supported ends of the I-joists. The hangers incorporate lateral load-resisting metal straps that are factory-welded to the supporting steel angle. The lateral load-resisting straps must be fastened to the I-joist top flange using Simpson SDS screws. See Figures 3 and 4 for typical hanger configurations and Table 3 for hanger dimensions, fastener schedule, and allowable loads. The hangers must be connected to the supporting structure using welds as described in Table 3.

#### 4.5 Duration of Load:

Adjustments for duration of load provided for wood members and their connections must be in accordance with this report and the NDS.

#### 4.6 In-service Moisture Conditions:

SSI I-joist properties and allowable loads in this report are limited to covered installations with dry conditions of use. Dry conditions of use are those in-service environmental conditions in which the moisture content is less than 16 percent. SSI Wood I-joist design values must be adjusted in accordance with Section 4.1.4 of the NDS when in-service moisture content exceeds 16 percent.

#### 4.7 Deflection:

Deflection of the I-joists under load must be calculated using standard engineering formulas, accounting for both flexural and shear deformation.

For simple span, non-tapered I-joists, having constant depth and a uniformly distributed load:

$$\Delta = \frac{5wL^4}{384EI} + \frac{wL^2}{K}$$

For simple span, nontapered I-joists, having constant depth and a concentrated load at mid-span:

$$\Delta = \frac{PL^3}{48EI} + \frac{2PL}{K}$$

where:

$K$  = Shear deflection constant. (See Tables 2A, 2B and 2C.)

$E$  = Modulus of elasticity of the flange material, multiplied by the moment of inertia. (See Tables 2A, 2B and 2C.)

$L$  = Span length, in inches (mm).

$P$  = Concentrated load, in pounds (N).

$W$  = Uniform load, in pounds per lineal inch (N/mm).

$\Delta$  = Deflection, in inches (mm).

#### 4.8 Blocking:

SSI I-joists with <sup>3</sup>/<sub>8</sub>-inch-thick and <sup>7</sup>/<sub>16</sub>-inch-thick webs, used as blocking, are capable of resisting a maximum vertical load of 2,200 lbf/ft (32 kN/m) for I-joist depths of 16 inches (406 mm) or less, and a maximum vertical load of 1,400 lbf/ft (20 kN/m) for I-joist depths greater than 16 inches and up to 24 inches (406 mm to 610 mm). SSI I-joists with <sup>1</sup>/<sub>2</sub>-inch-thick webs, used as blocking, are capable of resisting a maximum vertical load of 2,200 lbf/ft (32 kN/m) for I-joist depths of 24 inches (610 mm) or less.

#### 4.9 Web Stiffeners:

Intermediate web stiffeners are not required, except at locations where joists are supporting concentrated loads in excess of 1750 lbf (7790 N). See Table 1 for web stiffener details and Tables 2A, 2B and 2C for web stiffener required bearing conditions.

#### 4.10 Fasteners:

When fastening wood structural panel sheathing to the top flange of SSI Wood I-joists, except for SSI 44MX, with 10d common nails closer than 3 inches (70 mm) on center in a row, a reinforced top flange in accordance with Section 3.2.1.1 must be used. The allowable withdrawal and lateral loads for nails installed perpendicular or parallel to the wide face of the LVL flanges are the same as those provided in the applicable code for sawn lumber having a minimum specific gravity of 0.50, such as Douglas fir-larch. The allowable withdrawal and lateral loads for nails installed perpendicular or parallel to the wide or narrow

face of the solid sawn flanges, other than for the “Me” Series I-joists, are based on values provided in the NDS for lumber with a specific gravity of 0.50. Those for the “Me” Series I-joists are based on values provided in the NDS for lumber with a specific gravity of 0.46.

#### 4.11 Fire-resistance-rated Assemblies:

Basic construction details are noted in Figure 2 for the assemblies described below. Other installation and construction details not specifically covered in this report must be in accordance with [ESR-1405](#).

**4.11.1 Assembly 1:** The I-joists described in this report, with minimum flange size of 2<sup>1</sup>/<sub>2</sub> by 1<sup>1</sup>/<sub>2</sub> inches (64 mm by 38 mm), may be used in the assembly as described in Section 4.2.2.1 of [ESR-1405](#).

**4.11.2 Assembly 2:** The I-joists described in this report may be used in the appropriate assembly as described in Section 4.2.2.2 of [ESR-1405](#).

**4.11.3 Assembly 3—One-hour Fire-resistance-rated Roof/Floor-ceiling Assembly:** Wood structural panel sheathing, as required by the code, must be installed over SSI I-joists with nominally 3-by-2 flanges, spaced at a maximum of 24 inches (610 mm) on center. The ceiling must consist of a base layer of <sup>5</sup>/<sub>8</sub>-inch-thick (15.9 mm), Type X gypsum wallboard applied at right angles to SSI I-joists with 1<sup>1</sup>/<sub>4</sub>-inch (31.7 mm), Type S drywall screws, spaced at 24 inches (610 mm) on center. A face layer of <sup>5</sup>/<sub>8</sub>-inch-thick (15.9 mm), Type X gypsum wallboard, or Type X veneer base, must be applied at right angles to the I-joists and attached with 1<sup>7</sup>/<sub>8</sub>-inch (48 mm), Type S drywall screws, spaced at 12 inches (305 mm) on center at joints and intermediate supports. Face-layer joints must be offset 24 inches (610 mm) from base-layer joints. Type G drywall screws 1<sup>1</sup>/<sub>2</sub> inches long (38 mm) must be spaced at 12 inches (305 mm) on center and installed 2 inches (51 mm) back from either side of the face-layer end joints. Using the same spacing as for the screw, alternate fasteners are permitted to be 1<sup>7</sup>/<sub>8</sub>-inch-long (48 mm), 6d cooler, box or wallboard nails for the base layer, and 2<sup>3</sup>/<sub>8</sub>-inch-long (60 mm), 8d cooler, box or wallboard nails for the face layer. Type G drywall screws, 1<sup>1</sup>/<sub>2</sub> inches long (38 mm), must still be required at the end joints of the face layer. Exposed wallboard joints must be treated with paper tape embedded in joint compound, which then must be covered with two coats of joint compound in accordance with ASTM C 840 and GA-216. Screw heads must be covered with two coats of joint compound.

**4.11.4 Assembly 4—One-hour Fire-resistance-rated Floor-ceiling Assembly:** The assembly must consist of a single-layer floor of a minimum <sup>19</sup>/<sub>32</sub>-inch-thick (15.1 mm) structural-use wood-based sheathing (Exposure 1) with SSI I-joists with nominally 3-by-2 flanges spaced up to 24 inches (610 mm) on center, and a ceiling of two layers of gypsum wallboard attached to the bottom flange. The gypsum board must be <sup>1</sup>/<sub>2</sub>-inch-thick (12.7 mm) Type X for all installations. The structural wood panel floor sheathing must be applied perpendicular to the joists and attached with 6d ring- or screw-shank nails spaced at 6 inches (152 mm) on center. The gypsum board base layer must be applied perpendicular, and attached directly, to the bottom joist flange with 1<sup>1</sup>/<sub>4</sub>-inch-long (31.7 mm), Type S drywall screws, spaced at 24 inches (610 mm) on center. The face layer must be installed with joints staggered 24 inches (610 mm) and must be secured to each joist with 1<sup>7</sup>/<sub>8</sub>-inch-long (48 mm), Type S drywall screws spaced at 12 inches (305 mm) on center at joints and at intermediate supports. Additional 1<sup>1</sup>/<sub>2</sub>-inch-long (38 mm), Type G drywall screws are installed along the exposed butt-joints of the second

layer, spaced at 12 inches (305 mm) on center, in rows 3 inches (76 mm) back from the joint and staggered, with Type S screws in accordance with ASTM C 840 and GA-216. Exposed wallboard joints must be treated with paper tape embedded in joint compound and covered with two coats of joint compound. Screw heads must be covered with two coats of joint compound.

**4.11.5 Other Fire-resistive Assemblies:** The SSI I-joists described in this report may also be used in the assemblies described in IBC Table 720.1 (3), Item Numbers 23-1.1 and 25-1.1 through 29-1.1, provided the I-joists used meet the criteria described in the table’s “Floor and Roof” construction column. For the purposes of the minimum flange area requirement of 2.3 square inches (1480 mm<sup>2</sup>) in Item Number 23-1.1, a 1<sup>1</sup>/<sub>2</sub>-inch-by-1<sup>1</sup>/<sub>2</sub>-inch (38 mm by 38 mm) flange having a cross-sectional area of 2.25 square inches (1450 mm<sup>2</sup>) may be considered sufficient.

## 5.0 CONDITIONS OF USE

The SSI Wood I-Joists described in this report comply with, or are suitable alternatives to what is specified in, those codes listed in Section 1.0 of this report, subject to the following conditions:

- 5.1** Installation must comply with this report, the manufacturer’s published installation instructions and the applicable code. If there is a conflict between the manufacturer’s published installation instructions and this report, this report governs.
- 5.2** Allowable design properties for the SSI I-joists must not exceed the values shown in Tables 2A, 2B, and 2C of this report.
- 5.3** Design calculations and details for the use of SSI Wood I-Joists must be submitted to the code official. The calculations and details must be consistent with this report, and must be prepared by a registered design professional where required by the statutes of the jurisdiction in which the project is to be constructed.
- 5.4** Evaluation and use of SSI I-joists as components of fire-resistance-rated construction is as noted in Section 4.11 of this report.
- 5.5** Opening sizes and locations within SSI I-joists webs must conform to the requirements as set forth in Figure 1 of this report. Cutting and notching of SSI joist flanges is not permitted, except for cutting to proper length for installation.
- 5.6** The TGLTB3 EZ Weld hanger has been evaluated for use with SSI I-joists, in the depths and widths listed in Table 3 of this report. The hangers are manufactured by Tobin Steel Company, Inc., in Santa Ana, California, under a quality control program with inspections by R. I. Ogawa & Associates (AA-705).
- 5.7** SSI Wood I-joists are produced in Windsor, California, under a quality control program with inspections by APA—The Engineered Wood Association (AA-649).

## 6.0 EVIDENCE SUBMITTED

- 6.1** Data in accordance with the ICC-ES Acceptance Criteria for Prefabricated Wood I-Joists (AC14), dated October 2007 (editorially revised December 2008).
- 6.2** Data in accordance with the ICC-ES Acceptance Criteria for Joist Hangers and Similar Devices (AC13), dated October 2006 (corrected March 2007; editorially revised April 2008).

6.3 I-joint hanger testing and calculations for the TGLT hanger with seismic strap.

7.0 IDENTIFICATION

Each SSI Wood I-Joist must be marked with the name of the manufacturer (Standard Structures Inc.); the product trade name; the joist series; the production date; the plant number or address; the evaluation report number (ESR-1991); and the name of the inspection agency (APA-EWS).

Each TGLT hanger must be marked with the name of the fabricator (Tobin Steel Company); the name of the inspection agency (R. I. Ogawa & Associates, which performs special inspections in accordance with IBC Section 1704.2); the model number; and the evaluation report number (ESR-1991).

TABLE 1 – SSI JOIST WEB STIFFENER AND WEB FILLER <sup>1, 2, 3, 4, 5, 6, 7, 8</sup>

WEB STIFFENER NAILING REQUIREMENTS				SSI JOIST FACTORY ATTACHED WEB FILLER (3-1/2-inch net Thickness Assembly)			
DEPTH	3/8 INCH OSB	7/16 INCH OSB	1/2 INCH OSB		DESIGNATION	FILLER ASSEMBLY LENGTH	LATERAL LOAD CAPACITY
9.5" to 14"	Not Req'd	3-10d	4-10d		WF2	2' - 0"	up to 5,000 LBS
16"	3-10d	3-10d	4-10d		WF4	4' - 0"	up to 10,000 LBS
18"	4-10d	4-10d	5-10d				
20"	5-10d	5-10d	7-10d				
22"	7-10d	7-10d	8-10d				
24"	8-10d	8-10d	9-10d				
26"	9-10d	9-10d	11-10d				
28"	N/A	9-10d	11-10d				
30"	N/A	9-10d	11-10d				

For SI: 1 inch = 25.4 mm

<sup>1</sup>Web stiffener nailing with 10d common nails and with 10d common short nails at 3x nominal flanges.

<sup>2</sup>Secure stiffeners to joist as noted in table above.

<sup>3</sup>Stiffeners must be installed tight to bottom chord.

<sup>4</sup>Use 1x stiffeners with 3x joist, use 2x stiffeners with 4x joist

<sup>5</sup>1/8-inch gap minimum. 2-inch gap maximum for field installed web stiffeners. Factory installed web stiffeners may have a maximum gap of 4-inches.

<sup>6</sup>Web stiffeners may not be required for all installation conditions. See table 2A, 2B, and 2C for requirements.

<sup>7</sup>Web stiffeners are installed as shown, except in cases of concentrated loads, where web stiffeners are required, the gap must be at the bottom.

<sup>8</sup>The Factory Attached Web Filler dimensions "A", "B" and "C" must be provided by Designer for proper filler location on the joist.

**TABLE 2A- SSI JOIST DESIGN PROPERTIES** <sup>1, 2, 3, 4</sup>  
**MOMENT, SHEAR & END REACTION**

DESCRIPTION	OVERALL DEPTH (inches)	MOMENT <sup>(3)</sup> (ft-lbf)	2 1/2" BEARING W/STIFFENERS (lbf) <sup>(4)</sup>	2 1/2" BEARING W/O STIFFENERS (lbf)	1 3/4" BEARING W/STIFFENERS (lbf)	1 3/4" BEARING W/O STIFFENERS (lbf)	EI (Lbf-in <sup>2</sup> )	K (lbf-in/in)
SSI 32L (I-77) 2 1/2" x 1 1/2" LVL Flange 7/16 - Inch OSB WEB	9.5	5,320	1,885	1,460	1,720	1,460	285	5.41
	11.875	6,890	2,080	1,480	1,935	1,420	487	6.63
	14	8,295	2,260	1,500	2,125	1,385	717	7.75
	16	9,620	2,425	1,515	2,305	1,350	979	8.82
	18	10,940	2,590	1,530	2,485	1,320	1,287	9.89
	20	12,265	2,755	N/A	2,670	N/A	1,643	10.96
	22	13,585	2,920	N/A	2,850	N/A	2,048	12.04
	24	14,910	3,090	N/A	3,030	N/A	2,504	13.12
	26	16,185	3,255	N/A	3,210	N/A	3,013	14.20
	28	17,390	3,420	N/A	3,390	N/A	3,577	15.28
30	18,585	3,585	N/A	3,570	N/A	4,198	16.36	
SSI 42L (I-90) 3 1/2" x 1 1/2" LVL Flange 7/16 - Inch OSB WEB	9.5	7,550	1,885	1,460	1,720	1,460	396	5.48
	11.875	9,780	2,080	1,480	1,935	1,420	671	6.71
	14	11,780	2,260	1,500	2,125	1,385	984	7.84
	16	13,660	2,425	1,515	2,305	1,350	1,338	8.91
	18	15,540	2,590	1,530	2,485	1,320	1,751	9.99
	20	17,420	2,755	N/A	2,670	N/A	2,226	11.07
	22	19,300	2,920	N/A	2,850	N/A	2,763	12.16
	24	21,180	3,090	N/A	3,030	N/A	3,366	13.25
	26	22,995	3,255	N/A	3,210	N/A	4,034	14.34
	28	24,705	3,420	N/A	3,390	N/A	4,772	15.43
30	26,405	3,585	N/A	3,570	N/A	5,579	16.52	
SSI 43L 3 1/2" x 1 3/4" LVL Flange 7/16 - Inch OSB WEB	9.5	8,585	1,885	1,460	1,720	1,460	403	5.62
	11.875	11,200	2,080	1,480	1,935	1,420	690	6.81
	14	13,545	2,260	1,500	2,125	1,385	1,018	7.91
	16	15,705	2,425	1,515	2,305	1,350	1,388	8.97
	18	17,995	2,590	1,530	2,485	1,320	1,821	10.05
	20	20,160	2,755	N/A	2,670	N/A	2,318	11.13
	22	22,365	2,920	N/A	2,850	N/A	2,881	12.21
	24	24,575	3,090	N/A	3,030	N/A	3,511	13.30
	26	26,705	3,255	N/A	3,210	N/A	4,210	14.39
	28	28,710	3,420	N/A	3,390	N/A	4,980	15.47
30	30,705	3,585	N/A	3,570	N/A	5,822	16.56	
SSI 32MX 2 1/2" x 1 1/2" MSR Flange 1/2 - Inch OSB WEB	9.5	4,525	1,875	1,735	1,875	1,600	260	7.65
	11.875	5,860	2,115	1,735	2,065	1,735	443	9.39
	14	7,055	2,330	1,750	2,275	1,750	652	10.99
	16	8,175	2,530	1,750	2,475	1,750	890	12.50
	18	9,300	2,735	1,590	2,675	1,590	1,170	14.02
	20	10,425	2,935	1,590	2,875	1,590	1,494	15.55
	22	11,545	3,315	N/A	3,075	N/A	1,862	17.08
	24	12,670	3,335	N/A	3,275	N/A	2,276	18.62
	26	13,755	3,540	N/A	3,475	N/A	2,739	20.15
	28	14,775	3,740	N/A	N/A	N/A	3,252	21.68
30	15,790	3,940	N/A	N/A	N/A	3,816	23.21	
SSI 42MX 3 1/2" x 1 1/2" MSR Flange 1/2 - Inch OSB WEB	9.5	6,450	1,735	1,735	1,735	1,735	360	7.79
	11.875	8,355	2,060	1,735	2,065	1,735	610	9.54
	14	10,060	2,350	1,750	2,275	1,750	895	11.15
	16	11,665	2,620	1,750	2,475	1,750	1,216	12.68
	18	13,270	2,895	1,590	2,675	1,590	1,592	14.22
	20	14,875	3,165	1,590	2,875	1,590	2,023	15.77
	22	16,480	3,440	N/A	3,075	N/A	2,512	17.32
	24	18,085	3,710	N/A	3,275	N/A	3,060	18.87
	26	19,635	3,985	N/A	3,475	N/A	3,668	20.42
	28	21,090	4,255	N/A	N/A	N/A	4,338	21.97
30	22,540	4,530	N/A	N/A	N/A	5,072	23.53	
SSI 43MX 3 1/2" x 2 1/8" MSR Flange 1/2 - Inch OSB WEB	11.875	11,300	2,060	1,735	2,065	1,735	755	9.97
	14	13,750	2,350	1,750	2,275	1,750	1,124	11.49
	16	16,060	2,620	1,750	2,475	1,750	1,542	12.97
	18	18,365	2,895	1,590	2,675	1,590	2,031	14.47
	20	20,670	3,165	1,590	2,875	1,590	2,593	16.00
	22	22,975	3,440	N/A	3,075	N/A	3,230	17.53
	24	25,285	3,710	N/A	3,275	N/A	3,942	19.07
	26	27,515	3,985	N/A	3,475	N/A	4,731	20.62
	28	29,615	4,255	N/A	N/A	N/A	5,600	22.17
	30	31,700	4,530	N/A	N/A	N/A	6,550	23.72
SSI 44MX 3 1/2" x 3" MSR Flange 1/2 - Inch OSB WEB	14	18,108	2,350	1,750	2,275	1,750	1,359	12.27
	16	21,470	2,620	1,750	2,475	1,750	1,895	13.59
	18	24,760	2,895	1,590	2,675	1,590	2,525	14.99
	20	28,050	3,165	1,590	2,875	1,590	3,252	16.44
	22	31,340	3,440	N/A	3,075	N/A	4,077	17.93
	24	34,625	3,710	N/A	3,275	N/A	5,002	19.43
	26	37,810	3,985	N/A	3,475	N/A	6,028	20.95
	28	40,815	4,255	N/A	N/A	N/A	7,157	22.48
30	43,800	4,530	N/A	N/A	N/A	8,391	24.01	

For SI: 1 inch = 25.4 mm, 1ft-lbf = 1.356 N-m, 1 lbf-in<sup>2</sup> = 2.87 kN-mm<sup>2</sup>, 1 in-lbf/in = 4.45 N-mm/mm, 1lbf = 4.45N.

**TABLE 2A- SSI JOIST DESIGN PROPERTIES<sup>1,2,3,4</sup> - (Continued)**  
**MOMENT, SHEAR & END REACTION**

DESCRIPTION	OVERALL DEPTH (inches)	MOMENT <sup>(3)</sup> (ft-lbf)	2 1/2" BEARING W/STIFFENERS (lbf) <sup>(4)</sup>	2 1/2" BEARING W/O STIFFENERS (lbf)	1 3/4" BEARING W/STIFFENERS (lbf)	1 3/4" BEARING W/O STIFFENERS (lbf)	EI (Lbf-in <sup>2</sup> )	K (lbf-in/in)
SSI 32MXH 2 1/2" x 1 1/2" MSR Flange 1/2 - Inch OSB WEB	9.5	5,410	1,735	1,735	1,735	1,735	298	7.79
	11.875	7,000	2,060	1,735	2,065	1,735	509	9.54
	14	8,430	2,350	1,750	2,275	1,750	750	11.15
	16	9,770	2,620	1,750	2,475	1,750	1,024	12.68
	18	11,110	2,895	1,590	2,675	1,590	1,346	14.22
	20	12,455	3,165	1,590	2,875	1,590	1,718	15.77
	22	13,795	3,440	N/A	3,075	N/A	2,141	17.32
	24	15,140	3,710	N/A	3,275	N/A	2,618	18.87
	26	16,435	3,985	N/A	3,475	N/A	3,150	20.42
	28	17,655	4,255	N/A	N/A	N/A	3,740	21.97
30	18,865	4,530	N/A	N/A	N/A	4,388	23.53	
SSI 42MXH 3 1/2" x 1 1/2" MSR Flange 1/2 - Inch OSB WEB	9.5	7,710	1,735	1,735	1,735	1,735	413	7.79
	11.875	9,985	2,060	1,735	2,065	1,735	702	9.54
	14	12,020	2,350	1,750	2,275	1,750	1,029	11.15
	16	13,940	2,620	1,750	2,475	1,750	1,399	12.68
	18	15,855	2,895	1,590	2,675	1,590	1,831	14.22
	20	17,775	3,165	1,590	2,875	1,590	2,327	15.77
	22	19,690	3,440	N/A	3,075	N/A	2,889	17.32
	24	21,610	3,710	N/A	3,275	N/A	3,518	18.87
	26	23,460	3,985	N/A	3,475	N/A	4,218	20.42
	28	25,200	4,255	N/A	N/A	N/A	4,989	21.97
30	26,935	4,530	N/A	N/A	N/A	5,833	23.53	
SSI 43MXH 3 1/2" x 2 1/8" MSR Flange 1/2 - Inch OSB WEB	11.875	13,505	2,060	1,735	2,065	1,735	868	9.97
	14	16,430	2,350	1,750	2,275	1,750	1,292	11.49
	16	19,185	2,620	1,750	2,475	1,750	1,773	12.97
	18	21,945	2,895	1,590	2,675	1,590	2,336	14.47
	20	24,700	3,165	1,590	2,875	1,590	2,982	16.00
	22	27,455	3,440	N/A	3,075	N/A	3,714	17.53
	24	30,210	3,710	N/A	3,275	N/A	4,533	19.07
	26	32,875	3,985	N/A	3,475	N/A	5,441	20.62
	28	35,385	4,255	N/A	N/A	N/A	6,440	22.17
	30	37,880	4,530	N/A	N/A	N/A	7,533	23.72
SSI 44MXH 3 1/2" x 3" MSR Flange 1/2 - Inch OSB WEB	14	21,725	2,350	1,750	2,275	1,750	1,562	12.27
	16	25,655	2,620	1,750	2,475	1,750	2,179	13.59
	18	29,585	2,895	1,590	2,675	1,590	2,904	14.99
	20	33,515	3,165	1,590	2,875	1,590	3,740	16.44
	22	37,445	3,440	N/A	3,075	N/A	4,689	17.93
	24	41,370	3,710	N/A	3,275	N/A	5,752	19.43
	26	45,175	3,985	N/A	3,475	N/A	6,932	20.95
	28	48,765	4,255	N/A	N/A	N/A	8,231	22.48
30	52,335	4,530	N/A	N/A	N/A	9,650	24.01	

For SI: 1 inch = 25.4 mm, 1ft-lbf = 1.356 N-m, 1 lbf-in<sup>2</sup> = 2.87 kN-mm<sup>2</sup>, 1 in-lbf/in = 4.45 N-mm/mm, 1lbf = 4.45N.

<sup>1</sup>The allowable moment and shear values are for normal duration of load. The appropriate code must be reviewed for duration of load factor adjustments.

<sup>2</sup> Refer to Table 1 for web stiffener detail.

<sup>3</sup> Moment capacity of the I-joists, which must not be increased by any code allowed repetitive member use factor.

<sup>4</sup> In Table 2A the value noted for the 2 1/2-inch (64 mm) bearing with stiffeners corresponds to the allowable vertical shear.

TABLE 2B – SSI JOIST DESIGN PROPERTIES <sup>1, 2, 3, 4, 5</sup>

DESCRIPTION	OVERALL DEPTH (inches)	ALLOWABLE MOMENT <sup>(4)</sup> (ft-lbs)	ALLOWABLE VERTICAL SHEAR (lbs)	EI x 10 <sup>6</sup> (lb in <sup>4</sup> )	K x 10 <sup>6</sup> (lb in/in)	
SSI 22M 1 1/2" x 1 5/8" MSR Flange 3/8 – inch OSB Web	9.5	2,865	1,090	166	5.29	
	11.875	3,720	1,375	288	6.47	
SSI 32M 2 1/2" x 1 1/2" MSR Flange 3/8 – inch OSB Web	9.5	4,590	1,500	260	5.39	
	11.875	5,945	1,760	487	6.60	
	12	6,020	1,775	499	6.67	
	14	7,160	1,995	717	7.71	
	16	8,300	2,215	979	8.77	
	18	9,445	2,440	1,287	9.84	
	20	10,585	2,660	1,643	10.91	
	22	11,730	2,880	2,048	11.99	
SSI 42M 3 1/2" x 1 1/2" MSR Flange 3/8 – inch OSB Web	24	12,870	3,100	2,504	13.06	
	26	13,970	3,320	3,013	14.14	
	9.5	6,515	1,500	360	5.47	
	11.875	8,445	1,760	671	6.69	
	12	8,545	1,775	688	6.75	
	14	10,170	1,995	984	7.81	
	16	11,790	2,215	1,338	8.88	
	18	13,415	2,440	1,751	9.95	
SSI 42MH 3 1/2" x 1 1/2" MSR Flange 3/8 – inch OSB Web	20	15,035	2,660	2,226	11.04	
	22	16,660	2,880	2,763	12.12	
	24	18,285	3,100	3,366	13.20	
	26	19,850	3,320	4,034	14.29	
	9.5	7,785	1,500	413	5.47	
	11.875	10,090	1,760	702	6.69	
	12	10,210	1,775	719	6.75	
	14	12,150	1,995	1,029	7.81	
SSI 42MB 3 1/2" x 1 1/2" MSR Flange 3/8 – inch OSB Web	16	14,090	2,215	1,399	8.88	
	18	16,030	2,440	1,831	9.95	
	20	17,965	2,660	2,327	11.04	
	22	19,905	2,880	2,889	12.12	
	24	21,845	3,100	3,518	13.20	
	26	23,720	3,320	4,218	14.29	
	SSI 32MB 2 1/2" x 1 1/2" MSR Flange 3/8 – inch OSB Web	9.5	2,735	1,120	193	4.94
		11.875	3,545	1,420	330	6.18
14		4,270	1,710	482	7.28	
16		4,950	1,970	657	8.32	
SSI 32Me 2 1/2" x 1 1/2" MSR Flange 3/8 – inch OSB Web	9.5	3,755	1,500	234	5.39	
	11.875	4,865	1,760	398	6.60	
	12	4,925	1,775	408	6.67	
	14	5,860	1,995	587	7.71	
	16	6,790	2,215	801	8.77	
	18	7,725	2,440	1,053	9.84	
	20	8,660	2,660	1,344	10.91	
	22	9,595	2,880	1,675	11.99	
SSI 42Me 3 1/2" x 1 1/2" MSR Flange 3/8 – inch OSB Web	24	10,530	3,100	2,049	13.06	
	26	11,430	3,320	2,465	14.14	
	9.5	5,330	1,500	324	5.47	
	11.875	6,910	1,760	549	6.69	
	12	6,990	1,775	563	6.75	
	14	8,320	1,995	805	7.81	
	16	9,645	2,215	1,095	8.88	
	18	10,975	2,440	1,433	9.95	
SSI 42Me 3 1/2" x 1 1/2" MSR Flange 3/8 – inch OSB Web	20	12,305	2,660	1,821	11.04	
	22	13,630	2,880	2,261	12.12	
	24	14,960	3,100	2,754	13.20	
	26	16,240	3,320	3,301	14.29	

For SSI: 1 inch = 25.4 mm, 1ft-lb = 1.356 N-m, 1lb-in<sup>2</sup> = 2.87 kN-mm<sup>2</sup>, 1 in-lb/in = 4.45 mm-N/mm, 1lb = 4.45 N

<sup>1</sup>The allowable moment and shear values are for normal duration of load. The appropriate code must be reviewed for duration of load factor adjustments.

<sup>2</sup> Refer to Table 1 for web stiffener details

<sup>3</sup> Web stiffeners are not required at bearing points for SSI I-Joists up to 26 inches (660 mm) deep, provided design shear does not exceed 1,600 pounds-force (7,120 N). In all other cases, bearing stiffeners are required at all supports for joist depths exceeding 16 inches (406 mm). See Table 1 for stiffener details.

<sup>4</sup> Moment capacity of the I-joists, which must not be increased by any code allowed repetitive member use factor.

<sup>5</sup> The SSI Joists in Table 2B must have a minimum bearing length of 2 1/2 inches (64 mm) except that a minimum bearing length of 1 3/4 inches (44 mm) is permitted for all joists in Table 2B up to a maximum depth of 20 inches (508 mm).

TABLE 2C - I-JOIST DESIGN PROPERTIES <sup>(a)</sup>

Depth	Joist Designation	EI <sup>(b)</sup> 10 <sup>6</sup> lbf-in. <sup>2</sup>	M <sup>(c)</sup> lbf-ft	V <sup>(d)</sup> lbf	IR <sup>(e)</sup> lbf	ER <sup>(f)</sup> lbf	K <sup>(g)</sup> 10 <sup>6</sup> lbf
9-1/2"	PRI <sup>TM</sup> -20	145	2,520	1,120	1,700	830	4.94
	PRI <sup>TM</sup> -30	161	3,225	1,120	1,905	945	4.94
	PRI <sup>TM</sup> -40	193	2,735	1,120	2,160	1,080	4.94
	PRI <sup>TM</sup> -60	231	3,780	1,120	2,160	1,080	4.94
11 7/8"	PRI <sup>TM</sup> -20	253	3,265	1,420	2,160	830	6.18
	PRI <sup>TM</sup> -30	280	4,170	1,420	1,905	945	6.18
	PRI <sup>TM</sup> -40	330	3,545	1,420	2,500	1,200	6.18
	PRI <sup>TM</sup> -60	396	4,900	1,420	2,500	1,200	6.18
	PRI <sup>TM</sup> -80	547	6,940	1,420	2,760	1,280	6.18
14"	PRI <sup>TM</sup> -40	482	4,270	1,710	2,500	1,200	7.28
	PRI <sup>TM</sup> -60	584	5,895	1,710	2,500	1,200	7.28
	PRI <sup>TM</sup> -80	802	8,360	1,710	3,020	1,280	7.28
16"	PRI <sup>TM</sup> -40	657	4,950	1,970	2,500	1,200	8.32
	PRI <sup>TM</sup> -60	799	6,835	1,970	2,500	1,200	8.32
	PRI <sup>TM</sup> -80	1,092	9,690	1,970	3,020	1,280	8.32

- (a) The tabulated values are design values for normal duration of load. All values, except for EI and K, shall be permitted to be adjusted for other durations as permitted by code.
- (b) Bending stiffness (EI) of the I-joists.
- (c) Moment capacity (M) of the I-joists, which must not be increased by any code allowed repetitive member use factor.
- (d) Shear capacity (V) of the I-joists.
- (e) Intermediate reaction (IR) of the I-joists with a minimum bearing length of 3-1/2 inches without bearing stiffeners.
- (f) End reaction (ER) of the I-joists with a minimum bearing length of 1-3/4 inches without bearing stiffeners. Higher end reactions are permitted. For a bearing length of 4 inches the end reaction may be set equal to the tabulated shear value. Interpolation of the end reaction between 1-3/4 and 4-inch bearing is permitted. For end reaction values over 1,550 lbf, bearing stiffeners are required.
- (g) Coefficient of shear deflection (K). For calculating uniform load and center-point load deflections of the I-joist in a simple-span application, Use Equations 1 and 2

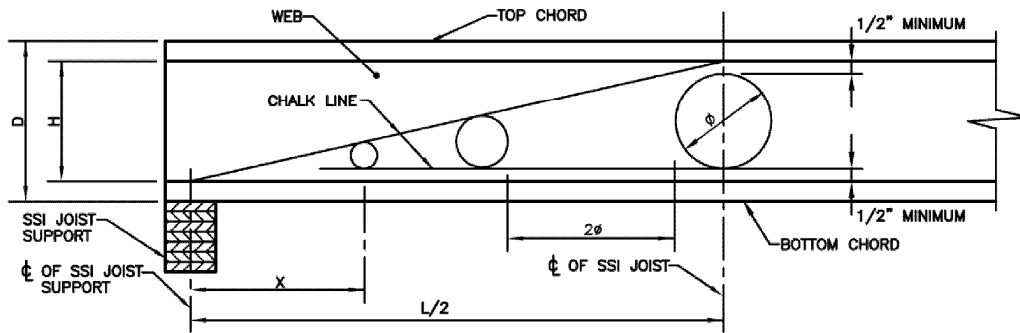

FIGURE 1 - TYPICAL HOLES - SPACING REQUIREMENTS

For simple span and uniform loads, the following formula must be used to determine hole spacing requirements:

$$X = \frac{3L\phi}{5H}$$

$$\phi = \frac{5XH}{3L}$$

- X = Distance, in feet, from centerline of support to the centerline of hole.
- L = Joist span, in feet, centerline of support to centerline of support.
- $\phi$  = Hole Diameter in inches
- H = Web depth in inches.

Notes:

- Round Holes The maximum diameter of round holes is 75 percent of the web depth.
- Square Holes The sides of the square holes must not exceed two thirds the maximum round holes diameter.
- Multiple Holes Where more than one hole is necessary, the distance between holes must exceed twice the diameter of the largest round hole or twice the side of the largest square hole.
- Special Exceptions will require that additional substantiating data be furnished to the local building department
- General Do not cut the web within D/2 of the support centerline otherwise 1 1/4-inch holes @ 24" o.c. can be cut in the web anywhere. The top and bottom chords are never to be cut.

For simple span and uniform loads a chalk-line can be used to show the allowable hole size permitted at a given location along the span. Do not increase the hole diameter beyond the allowable size. The holes must be placed anywhere in the vertical direction between the top and bottom flanges, provided a 1/2 inch gap is maintained between hole and flange. When joists are cantilevered or if concentrated loads are expected or where larger holes are desired than shown by the figure, contact the SSI Engineering Department for verification.

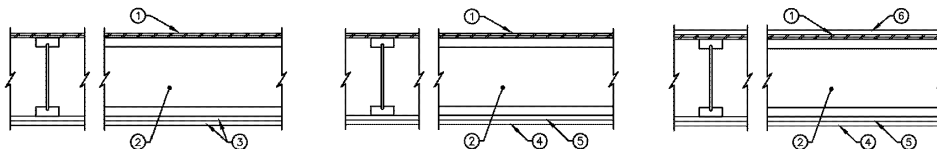

FIGURE 2 - FIRE ASSEMBLIES

1. Wood based structural use panel per US DOC PS-1 or PS-2 specifications.
2. SSI Joist
3. Two layers of gypsum wallboard
4. One layer of gypsum wallboard
5. Resilient Channel
6. Carpet/Pad (light-weight concrete as required)

Note: See section 4.10 for additional details

Welded Attachment (Footnote 3)

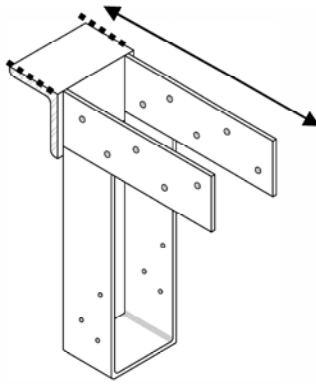

FIGURE 3  
TGLTB3 EZ Weld

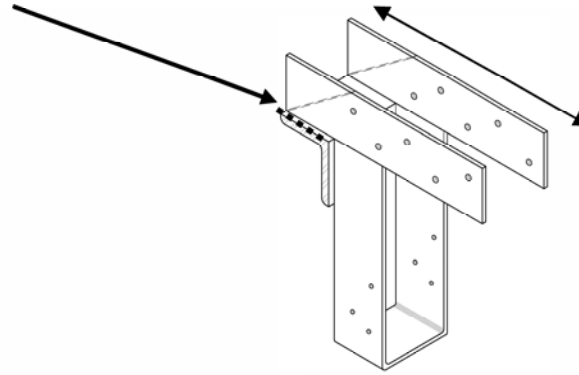

FIGURE 4  
TGLTB3 EZ Weld

TABLE 3 – LATERAL LOAD CAPACITY HANGER SCHEDULE 1, 2, 3, 4, 5, 6, 7, 8, 9, 10

Hanger Type	Depths (inches)	Width (inches)	Lateral Resistance Fasteners (quantity)	Lateral Load Capacity <sup>(1)</sup> <sup>(7)</sup> (pounds)	Vertical Load Capacity (pounds)	Uplift Capacity (pounds)	Hanger to Joist Nailing	Hanger to Support Attachment
								Weld Type and Length
TGLTB3 EZ Weld	14 16 18 20 22 24 26 30	3-5/8	SDS-6	4,032	7,190	1,190	3- 16d common wire per side	1/4" Fillet 1-1/8" per side
			SDS-8	5,376	7,190	1,190	3- 16d common wire per side	1/4" Fillet 1-1/2" per side
			SDS-10	6,720	7,190	1,190	3- 16d common wire per side	1/4" Fillet 1-7/8" per side
			SDS-12	8,064	7,190	1,190	3- 16d common wire per side	1/4" Fillet 2-1/4" per side
			SDS-14	9,408	7,190	1,190	3- 16d common wire per side	1/4" Fillet 2-9/16" per side
			SDS-16	10,752	7,190	1,190	3- 16d common wire per side	1/4" Fillet 3" per side
			SDS-18	12,096	7,190	1,190	3- 16d common wire per side	1/4" Fillet 3-3/8" per side
			SDS-20	13,440	7,190	1,190	3- 16d common wire per side	1/4" Fillet 3-3/4" per side

<sup>1</sup> Values are based on 672 pounds per each 1/4-inch x 2-1/2" inch Simpson SDS screw used. The 672 pounds includes an allowed 1.6 duration factor for lateral forces.

<sup>2</sup> The allowed duration of load increases are included in these tables. No additional duration of load increase allowed.

<sup>3</sup> EZ Weld Hanger must be welded to steel supports by a 1/4-inch fillet weld each side of supporting angle per the table. The Support base-metal must be a minimum of A36 Steel.

<sup>4</sup> The supporting structure must be designed by registered design professional in accordance with the applicable code.

<sup>5</sup> For field installation all hanger to joist nail and screw holes must be pre-drilled.

<sup>6</sup> Values in the Table were developed using lumber with a specific gravity of 0.50 or higher.

<sup>7</sup> The double ended arrows on Figures 3 and 4 above show the direction of lateral forces.

<sup>8</sup> EZ-Weld Hanger use is limited to members with a minimum flange thickness of 3-inches.

<sup>9</sup> EZ-Weld Hanger applications are limited to parallel flange members.

<sup>10</sup> Check required by Designer for combined stress due to Dead-load, Live-load and Axial (EQ or WL).

TABLE 4 - REINFORCED FLANGE (R-CHORD) ADJUSTMENT TABLE

Properties of SSI Joists with Reinforced Flanges in Tables 2A and 2B must be adjusted by **multiplying** with the following factors

Depth	9.5	11.875	12	14	16	18	20	22	24	26	28	30
Shear	0.947	0.958	0.958	0.964	0.969	0.972	0.975	0.977	0.979	0.980	0.982	0.983
Moment	0.938	0.949	0.952	0.958	0.962	0.967	0.971	0.974	0.978	0.980	0.982	0.983
EI x 10 <sup>6</sup>	0.814	0.889	0.904	0.912	0.925	0.934	0.941	0.947	0.952	0.956	0.959	0.962