

ICC-ES Evaluation Report

ESR-2048

Reissued March 1, 2011

This report is subject to renewal in two years.

www.icc-es.org | (800) 423-6587 | (562) 699-0543

A Subsidiary of the International Code Council®

**DIVISION: 07 00 00—THERMAL AND MOISTURE
PROTECTION**
Section: 07 41 13—Metal Roof Panels
REPORT HOLDER:
CUSTOM-BILT METALS
 13940 MAGNOLIA AVENUE
 CHINO, CALIFORNIA 91710-7029
 (909) 664-1500
www.custombiltmetals.com
EVALUATION SUBJECT:
**CUSTOM-BILT STANDING SEAM METAL ROOF
PANELS: CB-150 AND SL-1750**

1.0 EVALUATION SCOPE

Compliance with the following codes:

- 2006 *International Building Code*® (IBC)
- 2006 *International Residential Code*® (IRC)

Properties evaluated:

- Weather resistance
- Fire classification
- Wind uplift resistance

2.0 USES

Custom-Bilt Standing Seam Metal Roof Panels are steel panels complying with IBC Section 1507.4 and IRC Section R905.10. The panels are recognized for use as Class A roof coverings when installed in accordance with this report.

3.0 DESCRIPTION

3.1 Roofing Panels:

Custom-Bilt standing seam roof panels are fabricated in steel and are available in the CB-150 and SL-1750 profiles. The panels are roll-formed at the jobsite to provide the standing seams between panels. See Figures 1 and 3 for panel profiles.

The standing seam roof panels are roll-formed from minimum No. 24 gage [0.024 inch thick (0.61 mm)] cold-formed sheet steel. The steel conforms to ASTM A 792, with an aluminum-zinc alloy coating designation of AZ50.

The panel profiles are as follows:

- CB-150: This profile is formed to 12- or 16-inch-wide (305 or 406 mm) panels, with 1¹/₂-inch-high (38 mm) mechanically locking seams. See Figure 1.

- SL-175: This profile is formed to 14- or 18-inch-wide (356 or 457 mm) panels, with 1³/₄-inch-high (44 mm) snap-locking seams. See Figure 3.

3.2 Decking:

Solid or closely fitted decking must be minimum ¹⁵/₃₂-inch-thick (11.9 mm) wood structural panel or lumber sheathing, complying with IBC Section 2304.7.2 or IRC Section R803, as applicable.

3.3 Underlayment and Flashing:

Underlayment (optional), when used, must comply with ASTM D 226. Flashing must be in accordance with the applicable code.

3.4 Panel Clips:

Panel clips are supplied by Custom-Bilt, and are fabricated from ASTM A 653 sheet steel with a zinc coating designation of G90, and a base-metal thickness of 0.024 inch [0.61 mm (No. 24 gage)] for the CB-150 and 0.048 inch [1.22 mm (No. 18 gage)] for the SL-1750. See Figures 2 and 4 for panel clips and dimensions.

3.5 Fasteners:

Panel clips are supplied by Custom-Bilt, and are fabricated from ASTM A 653 sheet steel with a zinc coating designation of G90, and a base-metal thickness of 0.024 inch [0.61 mm (No. 24 gage)] for the CB-150 and 0.048 inch [1.22 mm (No. 18 gage)] for the SL-1750. See Figures 2 and 4 for panel clips and dimensions.

4.0 DESIGN AND INSTALLATION

4.1 General:

Installation of the Custom-Bilt Standing Seam Roof Panels must be in accordance with this report, Section 1507.4 of the IBC or Section R905.10 of the IRC, and the manufacturer's published installation instructions. The manufacturer's installation instructions must be available at the jobsite at all times during installation.

The roof panels must be installed on solid or closely fitted decking, as specified in Section 3.2. Accessories such as gutters, drip angles, fascias, ridge caps, window or gable trim, valley and hip flashings, etc., are fabricated to suit each job condition. Details must be submitted to the code official for each installation.

4.2 Roof Panel Installation:

4.2.1 CB-150: The CB-150 roof panels are installed on roofs having a minimum slope of 2:12 (17 percent). The roof panels are installed over the optional underlayment and secured to the sheathing with the panel clip shown in Figure 2. The clips are located at each panel rib side lap spaced 6 inches (152 mm) from all ends and at a maximum of 4 feet (1.22 m) on center along the length of the rib, and fastened with a minimum of two No. 10 by 1-inch pan head corrosion-resistant screws. The panel ribs are mechanically seamed twice, each pass at 90 degrees, resulting in a double-locking fold as shown in Figure 1.

4.2.2 SL-1750: The SL-1750 roof panels are installed on roofs having a minimum slope of 3:12 (25 percent). The roof panels are installed over the optional underlayment and secured to the sheathing with the panel clips shown in Figure 4. The clips are located at each panel rib side lap spaced 6 inches (152 mm) from all ends and at a maximum of 3 feet (914 mm) on center along the length of the rib, and fastened with a minimum of two No. 10 by 1-inch pan head corrosion-resistant screws. After installation of fasteners along one side, each panel is lapped over the preceding panel and snap-locked into place.

4.3 Fire Classification:

The steel panels are considered Class A roof coverings in accordance with the exception to IBC Section 1505.2 and IRC Section R902.1.

4.4 Wind Uplift Resistance:

The systems described in Section 3.0 and installed in accordance with Sections 4.1 and 4.2 have an allowable wind uplift resistance of 45 pounds per square foot (2.15 kPa).

5.0 CONDITIONS OF USE

The standing seam metal roof panels described in this report comply with, or are suitable alternatives to what is specified in, those codes listed in Section 1.0 of this report, subject to the following conditions:

5.1 Installation must comply with this report, the applicable code, and the manufacturer's published installation instructions. If there is a conflict between this report and the manufacturer's published installation instructions, this report governs.

5.2 The required design wind loads must be determined for each project. Wind uplift pressure on any roof area must not exceed 45 pounds per square foot (2.15 kPa).

6.0 EVIDENCE SUBMITTED

Data in accordance with the ICC-ES Acceptance Criteria for Metal Roof Coverings (AC166), dated May 2008.

7.0 IDENTIFICATION

Each standing seam metal roof panel is identified with a label bearing the product name, the material type and gage, the Custom-Bilt Metals name and address, and the evaluation report number (ESR-2048).

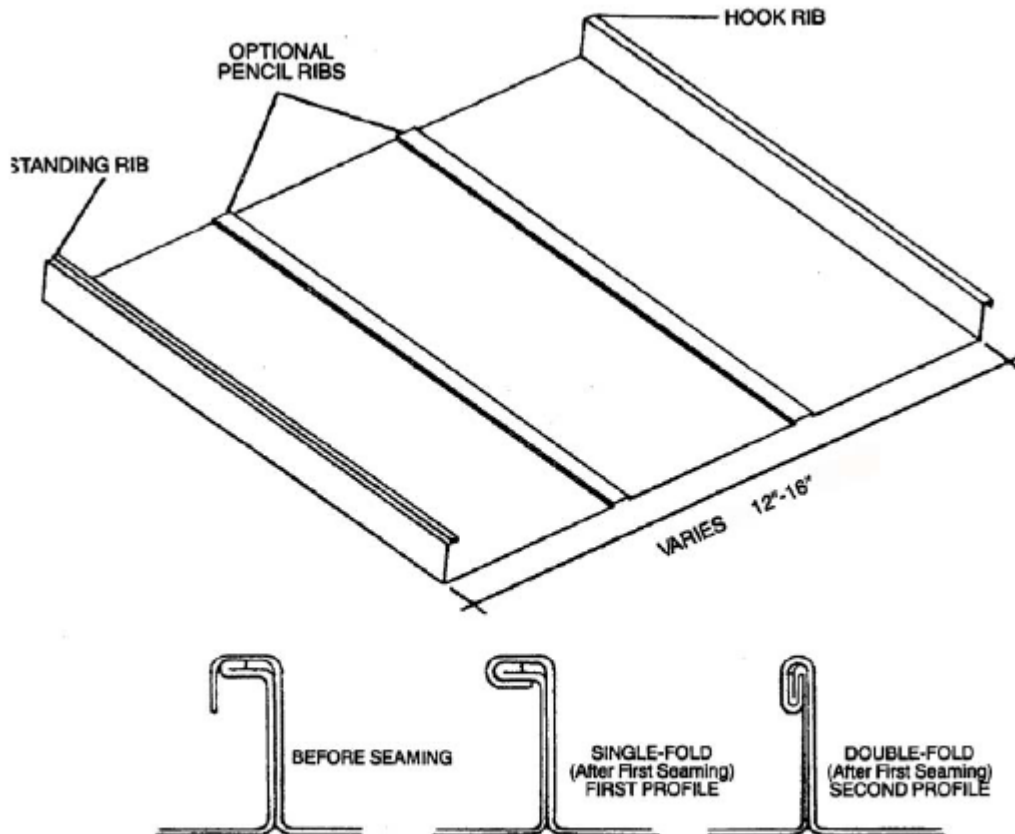

FIGURE 1—CB-150 PANEL
For SI: 1 inch = 25.4 mm

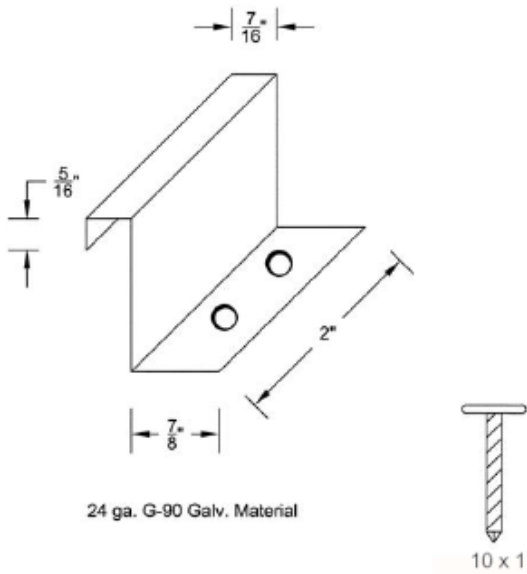

FIGURE 2—CB-150 ANCHOR CLIP
For SI: 1 inch = 25.4 mm

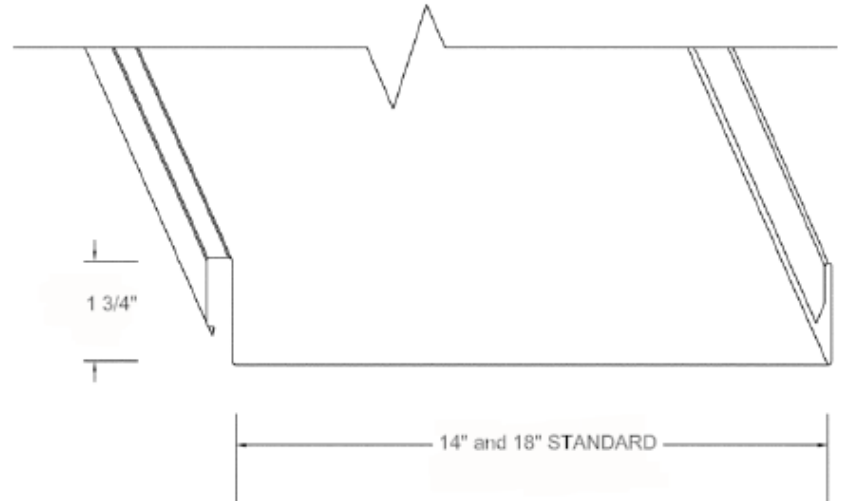

FIGURE 3—SL-1750 PANEL
For SI: 1 inch = 25.4 mm

18 gauge Galv.

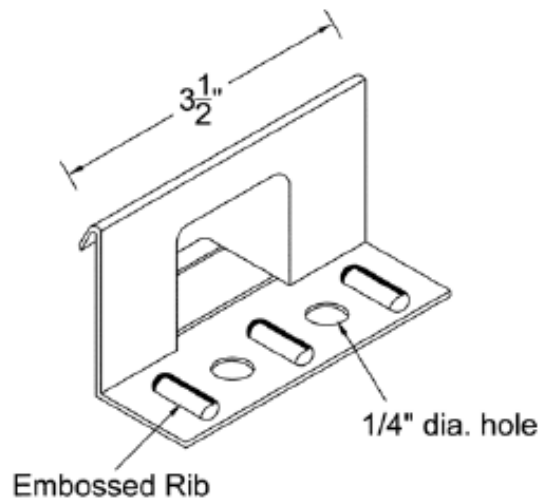
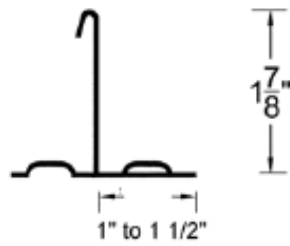

FIGURE 4—SL-1750 ANCHOR CLIP
For SI: 1 inch = 25.4 mm