

# ICC-ES Evaluation Report

**ESR-2452**

Reissued March 1, 2011

*This report is subject to renewal in two years.*[www.icc-es.org](http://www.icc-es.org) | (800) 423-6587 | (562) 699-0543

A Subsidiary of the International Code Council®

**DIVISION: 05 00 00—METALS**  
**Section: 05 50 00—Metal Fabrications****REPORT HOLDER:****AFCO MANUFACTURING CORPORATION**  
POST OFFICE BOX 230  
HOLLY, MICHIGAN 48442  
(248) 634-4415  
[www.afcomfg.com](http://www.afcomfg.com)**EVALUATION SUBJECT****“ZIP” ADJUSTABLE COLUMNS****1.0 EVALUATION SCOPE****Compliance with the following codes:**

- 2009 *International Building Code*® (2009 IBC)
- 2009 *International Residential Code*® (2009 IRC)
- 2006 *International Building Code*® (2006 IBC)
- 2006 *International Residential Code*® (2006 IRC)

**Property evaluated:**

Structural

**2.0 USES**

The “Zip” Adjustable Columns are prefabricated steel column assemblies used as structural members to transfer axial compressive loads from wood or steel beams to concrete footings. They may be used under the IRC when an engineered design is prepared in accordance with IRC Section R301.1.3.

**3.0 DESCRIPTION****3.1 General:**

The “Zip” Adjustable Columns are comprised of round tubing, with a top plate welded to the top and a screw jack assembly welded to the bottom of the tubing. The screw jack assembly consists of a screw plate, a screw, a collar and an optional turn bar for adjusting the column length. The columns are available in five models with nominal diameters and base-metal wall thicknesses as shown in Table 1. All columns are available in lengths ranging from 1 foot to 12 feet (305 to 3658 mm). The screw jack assembly allows the column to be adjusted up to 4 inches (102 mm) in length. The assembly is painted with a primer.

**3.2 Models 3X, 35, 4X:**

For models 3X, 35 and 4X, the tubing conforms to ASTM A 513, Type 1, Grade 1008-1010, with a minimum yield stress of 30 ksi (206 MPa). The screw is fabricated from

steel bar conforming to ASTM A 108, minimum grade 1200. The screw has a nominal diameter of 1<sup>1</sup>/<sub>4</sub> inches (32 mm) and a length of 6.25 inches (159 mm). The collar is fabricated from steel bar conforming to ASTM A 576, minimum grade 1100. The collar is <sup>3</sup>/<sub>4</sub> inch thick (19 mm) with a threaded hole for the screw, and is butt welded to the bottom of the tubing.

**3.3 Models 34 and 36:**

For models 34 and 36, the tubing conforms to ASTM A 500 Grade B, with a minimum yield stress of 42 ksi (290 MPa). The screw is fabricated from steel bar conforming to ASTM A 108, minimum grade 1200. The screw has a nominal diameter of 1<sup>1</sup>/<sub>4</sub> inches (32 mm) and a length of 6.25 inches (159 mm). The collar is fabricated from steel bar conforming to ASTM A 576, minimum grade 1100. The collar is 1 inch thick (25.4 mm) with a threaded hole for the screw, and is butt welded to the bottom of the tubing.

**3.4 Screw Plates:**

Two screw plates are available and are used interchangeably. They are fabricated from steel complying with ASTM A 568, Grade 1008-1010. The minimum yield strength is 37.3 ksi (257 MPa).

**3.5 Top Plates:**

Four top plates are available and are used interchangeably. Three are H-shaped plates and the fourth is a combination plate, comprised of a rectangular plate and H-shaped plate. The top plates are fabricated from steel conforming to ASTM A 568, grade 1008-1010, with a minimum yield strength of 37.3 ksi (257 MPa). The top plates are welded to the tubing at the manufacturing facility.

**4.0 DESIGN AND INSTALLATION****4.1 Design:**

Design loads determined in accordance with IBC Section 1605.3 [for allowable stress design (ASD)] must not exceed the allowable loads given in Table 2. Design loads determined in accordance with IBC Section 1605.2 [for load and resistance factor design (LRFD)] must not exceed the design strengths given in Table 2. The capacity of the end plates must be calculated in accordance with applicable code requirements for the steel, concrete or wood to determine whether the supplied end plate thickness is adequate for the applied load interface (wood beams, steel beams or concrete).

**4.2 Installation:**

Installation of the “ZIP” Adjustable Columns described in this report must comply with this report and the manufacturer’s published installation instructions. The

manufacturer’s published installation instructions and the approved plans must be available at the jobsite at all times during installation.

The columns must be supported on code-complying foundations capable of supporting the imposed load. The columns are placed vertically in the desired position under the beam, with the screw jack assembly at the bottom. The screw plate must be anchored to the foundation in accordance with the approved plans. The column must be adjusted to ensure full bearing of the beam on the cap plate. Maximum length adjustment of the columns is 4 inches (102 mm). After the column has been adjusted to the desired length, one screw thread must be damaged to one half its depth for a length of 1 1/2 inches (38 mm) with a cold chisel or screw driver to prevent vertical movement of the column. The top plate must be attached to the supported beam in accordance with the approved plans.

**5.0 CONDITIONS OF USE**

The "ZIP" Adjustable Columns described in this report comply with, or are suitable alternatives to what is specified in, those codes listed in Section 1.0 of this report, subject to the following conditions:

- 5.1 The column assemblies must be fabricated and installed in accordance with this report, the manufacturer’s published installation instructions, the approved plans and the applicable code. In the event of a conflict between the manufacturer’s published installation instructions and this report, this report governs.
- 5.2 Where required by the code official, engineering calculations and construction documents consistent with this report must be submitted for approval. The documents must contain details of the attachment to the structure consistent with the requirements of this

report. The documents must be prepared by a registered design professional where required by the statutes of the jurisdiction in which the project is to be constructed.

- 5.3 Loading on the columns must be limited to concentric axial compressive loads, in accordance with Section 4.1. Other loading conditions, such as but not limited to, eccentric loads, tensile axial loads, bending loads, and lateral loads, are outside the scope of this report.
- 5.4 Connections of the post to the foundation and the supported construction, and bearing capacity of the supported beam, are outside the scope of this report and must be approved by the code official.
- 5.5 Maximum adjustment of the adjustable columns is 4 inches (102 mm) and the overall column height must be limited to the maximum height given in Table 2.
- 5.6 "Zip" Adjustable Columns are manufactured in Holly, Michigan, under a quality control program with inspections by Professional Service Industries, Inc. [PSI (AA-660)].

**6.0 EVIDENCE SUBMITTED**

Data in accordance with the ICC-ES Acceptance Criteria for Adjustable Steel Columns (AC335), dated February 2008 (editorially revised March 2011).

**7.0 IDENTIFICATION**

"Zip" Adjustable Columns are labeled with the manufacturer's name (AFCO Mfg. Corp.), the product name and model, the length, the design thickness, the name of the inspection agency (PSI) and the evaluation report number (ESR-2452).

**TABLE 1—AFCO COLUMN MODELS**

MODEL	OUTSIDE DIAMETER (inches)	NOMINAL WALL THICKNESS (inch)	DESIGN THICKNESS (inch)
3X	3.0	0.120	0.120
35	3.5	0.120	0.120
4X	4.0	0.120	0.120
34	3.5	0.216	0.205
36	4.0	0.226	0.214

For SI: 1 inch = 25.4 mm.

**TABLE 2—CONCENTRIC AXIAL COMPRESSION ALLOWABLE LOAD AND DESIGN STRENGTH CAPACITIES OF ZIP ADJUSTABLE COLUMNS (lbf)**

HEIGHT	MODEL									
	3X		35		4X		34		36	
	Allowable Load (for ASD)	Design Strength (for LRFD)	Allowable Load (for ASD)	Design Strength (for LRFD)	Allowable Load (for ASD)	Design Strength (for LRFD)	Allowable Load (for ASD)	Design Strength (for LRFD)	Allowable Load (for ASD)	Design Strength (for LRFD)
6'0" - 6'4"	12,160	19,455	15,245	24,395	18,255	29,210	25,580	40,905	31,080	49,695
6'3" - 6'7"	11,925	19,080	15,030	24,050	18,060	28,900	25,580	40,905	31,080	49,695
6'6" - 6'10"	11,685	18,695	14,810	23,695	17,860	28,575	25,580	40,905	31,080	49,695
6'9" - 7'1"	11,440	18,305	14,585	23,335	17,655	28,245	25,580	40,905	31,080	49,695
7'0" - 7'4"	11,195	17,910	14,355	22,970	17,440	27,905	25,580	40,905	31,080	49,695
7'3" - 7'7"	10,945	17,510	14,125	22,595	17,225	27,560	25,580	40,905	31,080	49,695
7'6" - 7'10"	10,690	17,105	13,885	22,215	17,005	27,210	25,580	40,905	31,080	49,695
7'9" - 8'1"	10,440	16,700	13,645	21,830	16,780	26,850	25,580	40,905	31,080	49,695
8'0" - 8'4"	10,180	16,290	13,400	21,440	16,550	26,480	25,580	40,905	31,080	49,695
8'3" - 8'7"	9,925	15,875	13,150	21,040	16,320	26,110	25,580	40,905	31,080	49,695
8'6" - 8'10"	9,665	15,465	12,900	20,645	16,085	25,730	25,580	40,905	31,080	49,695
8'9" - 9'1"	9,405	15,050	12,650	20,240	15,845	25,350	25,580	40,905	31,080	49,695
9'0" - 9'4"	9,150	14,635	12,395	19,835	15,600	24,960	25,315	40,505	31,080	49,695
9'3" - 9'7"	8,890	14,420	12,140	19,425	15,355	24,570	24,550	39,280	31,080	49,695
9'6" - 9'10"	8,630	13,810	11,885	19,015	15,110	24,175	23,790	38,060	31,080	49,695
9'9" - 10'1"	8,375	13,400	11,625	18,600	14,860	23,775	23,035	36,850	31,080	49,695
10'0" - 10'4"	8,120	12,990	11,370	18,190	14,610	23,375	22,280	35,650	31,080	49,695

For SI: 1 inch = 25.4 mm, 1 foot = 305 mm, 1 lbf = 4.4 N.

Note: LRFD Design Strength must be compared to factored loads.

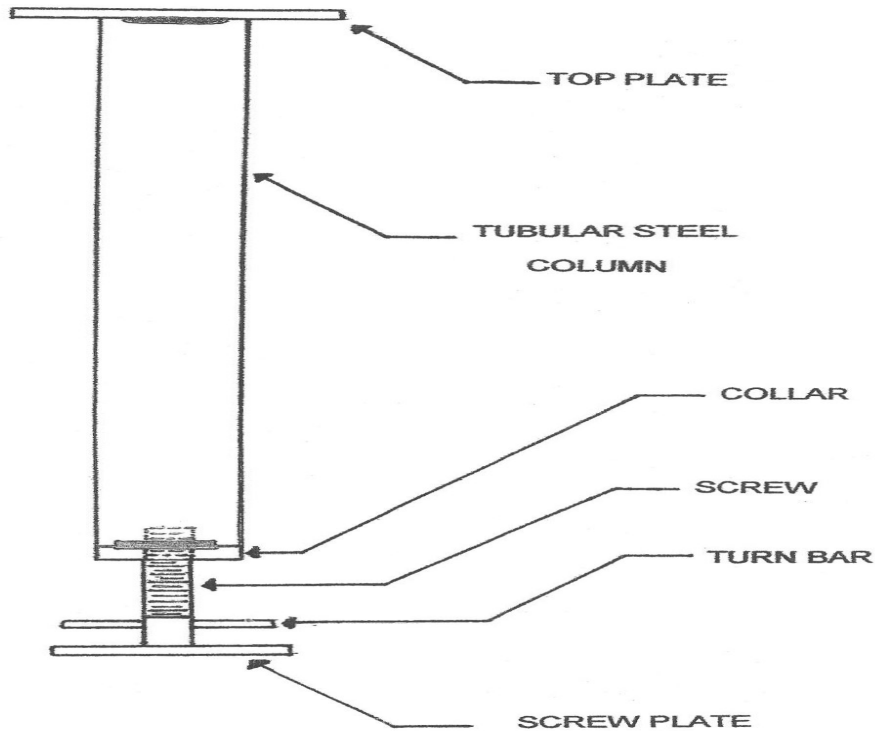

**FIGURE 1—“ZIP” ADJUSTABLE COLUMN**