

ICC-ES Evaluation Report

ESR-2551

Reissued January 2025

This report also contains:



- [City of LA Supplement](#)

Subject to renewal January 2026

- [FL Supplement](#)

ICC-ES Evaluation Reports are not to be construed as representing aesthetics or any other attributes not specifically addressed, nor are they to be construed as an endorsement of the subject of the report or a recommendation for its use. There is no warranty by ICC Evaluation Service, LLC, express or implied, as to any finding or other matter in this report, or as to any product covered by the report.

Copyright © 2025 ICC Evaluation Service, LLC. All rights reserved.

<p>DIVISION: 06 00 00— WOOD, PLASTICS, AND COMPOSITES</p> <p>Section: 06 05 23— Wood, Plastic, and Composite Fastenings</p>	<p>REPORT HOLDER: SIMPSON STRONG-TIE COMPANY INC.</p> 	<p>EVALUATION SUBJECT: SIMPSON STRONG-TIE® ADJUSTABLE HANGERS AND HIP CONNECTORS FOR WOOD FRAMING</p>	
---	--	---	---

1.0 EVALUATION SCOPE

Compliance with the following codes:

- 2021, 2018, 2015, 2012 and 2009 [International Building Code® \(IBC\)](#)
- 2021, 2018, 2015, 2012 and 2009 [International Residential Code® \(IRC\)](#)

Property evaluated:

Structural

2.0 USES

The Simpson Strong-Tie® adjustable hangers and hip connectors described in this report are used as wood framing connectors in accordance with Section [2304.10.4](#) of the 2021 IBC, Section [2304.10.3](#) of the 2018 and 2015 IBC, or Section [2304.9.3](#) of the 2012 and 2009 IBC. The connectors may also be used in structures regulated under the IRC when an engineered design is submitted in accordance with Section [R301.1.3](#) of the IRC.

3.0 DESCRIPTION

3.1 General:

The connectors described in this report have a general attribute of field adjustability to form specific connections for one or more roof framing members that intersect at different angles and slopes or to form specified connections for wood trusses, beams, and prefabricated wood I-joists.

3.1.1 HCP Hip-Corner Plate: The HCP hip-corner plate connects a hip roof rafter or beam to the double top plates of two intersecting walls at a 45-degree angle. The connectors are die formed from No. 18 gage galvanized steel. See [Table 1](#) for the connector plate models, connector dimensions, required fasteners, and allowable loads. See [Figure 1a](#) for a drawing of the HCP connector and [Figure 1b](#) for a drawing of a typical installation where the HCP connector is nailed to a roof hip member and the outside corner of the intersecting double top plates.

3.1.2 HRC Hip-Ridge Connector Plate: The HRC hip-ridge connector attaches two 45-degree skewed roof hip members to the end of a ridge member or the flat side of a truss. The U-shaped stirrups of the HRC

connectors support the roof hip members, and may be field-adjusted to a slope up to 45 degrees from the horizontal without adversely affecting the load-carrying capacity of the connector. The HRC22 and HRC1.81 connectors are fabricated from No. 16 gage galvanized steel. See [Table 2](#) for the HRC connector models, connector dimensions, required fasteners, and allowable loads. See [Figure 2](#) for drawings of the HRC connectors and a typical installation.

3.1.3 LSU and LSSU Sloped and Skewed Hangers: The LSU and LSSU hanger series are used to attach wood joists or rafters to wood headers, and may be sloped up or down and skewed left or right, up to 45 degrees. The connectors are die-formed from No. 18 gage galvanized steel. See [Table 3](#) for the hanger model numbers, hanger dimensions, required fasteners, and allowable loads. See [Figure 3](#) for drawings of a LSU and LSSU hangers and typical installations.

3.1.4 THA and THAC Adjustable Truss Hangers: THA and THAC adjustable truss hangers are U-shaped hangers designed for use with wood trusses and wood beams or headers. The hangers have long straight straps that can be field-formed to adjust the location of the truss or beam relative to the carrying member. The THA29, THA213, THA218, and THA418 hangers are formed from No. 18 gage galvanized steel. The THA218-2, THA222-2, THA418, THAC418, THA422 and THAC422 hangers are formed from No. 16 gage galvanized steel. The THA426, THA422-2 and THA426-2 are formed from No. 14 gage galvanized steel. See [Table 4](#) for hanger model numbers, hanger dimensions, required fasteners, and allowable loads. Two different installation methods may be used:

1. Minimum nailing schedule, which requires for the THA29 the use of double-shear (slant) nailing for the joist (carried member), and the hanger straps to be field-formed (bent) over the header a minimum of 2½ inches (63.5 mm) and nailed according to the requirements shown in [Table 4](#). The minimum nailing schedule for other hangers requires the hanger straps to be bent over the top of the header (carrying member) a minimum of 1½ inches (38.1 mm) for the THA213 and THA413 hangers, and a minimum of [Table 4](#); or
2. Maximum nailing schedule, which requires all nails to be installed into the face of the carrying member in accordance with [Table 4](#), and nails used for the joist attachment to be driven at a 45-degree angle so that they penetrate through the corner of the joist into the header, i.e., double shear nailing.

See [Figure 4](#) for drawings of typical THA and THAC hangers, and the THA29 hanger, and a typical installation of a THA hanger supporting a nominally 4-by-2 floor truss where the hanger straps are field-bent and nailed to the supporting wood member, and a detail of double shear (slant) nailing.

3.1.5 THAI Adjustable I-Joist Hanger: The THAI adjustable I-joist hangers have long straight straps that can be field-formed to ensure the top flange of the supported prefabricated wood I-joist is level relative to the supporting wood member. The hangers are formed from No. 18 gage galvanized steel. See [Table 5A](#) for hanger model numbers, hanger dimensions, and the width and depth of I-joists intended for use with each model. See [Table 5B](#) for fastener schedules and allowable loads. See [Figure 5](#) for drawings of a typical THAI hanger and a typical installation.

3.1.6 THAL/R422 Adjustable Truss Hangers: The THAL422 and THAR422 adjustable truss hangers have a standard skew of 45 degrees and support nominally 4-by-2 floor trusses and nominally 4-inch-wide wood beams. The hangers have long straps that must be bent over the top of the supporting wood member and nailed to the face and top of the carrying member according to the fastener schedule requirements shown in [Table 6](#). The hangers are formed from No. 16 gage galvanized steel. The THAR and THAL are mirror image identical hangers skewed at 45 degrees right and left, respectively. See [Table 6](#) for the hanger dimensions, required fasteners, and allowable loads. Two different installation methods may be used:

1. Minimum nailing schedule, which requires the hanger straps to be field-formed (bent) over the header a minimum of 2½ inches (63.5 mm) and nailed into the face of the carrying member with two nails as specified in [Table 6](#); or
2. Maximum nailing schedule, which requires the hanger straps to be field-formed (bent) over the header a minimum of 2½ inches (63.5 mm) and nailed into the face of the carrying member with twelve nails as specified in [Table 6](#).

See [Figure 6](#) for a drawing of a THAL/R422 hanger.

3.1.7 VPA Variable Pitch Connectors: VPA variable pitch connectors are field-formed and are used to connect wood roof rafters to wall top plates. The connector can be field-bent to accommodate rafter slopes

between 3:12 (14 degrees) and 12:12 (45 degrees). The U-shaped portion of the VPA connector provides a seat for the roof rafter, and the top flange (Flange A) and face flange (Flange B) of the connector are bent and nailed to the wall top plate, as shown in [Figure 7](#). The connectors are formed from No. 18 gage galvanized steel. See [Table 7](#) for connector model numbers, the width of the U-shaped rafter seat, required fasteners, and allowable loads. See [Figure 7](#) for drawings of a VPA connector and a typical installation detail.

3.1.8 LRUZ Series Hangers: The LRUZ series hangers are die-formed from No. 18 gage galvanized steel and are used to connect rafter or joist members to a supporting ridge, rim or header member. See [Table 8](#) for the LRUZ series hanger model numbers, hanger dimensions, required fasteners, and allowable loads. See [Figure 8](#) for a drawing of a typical LRUZ hanger and installation.

3.1.9 HHRC Heavy Hip-Ridge Connector Plate: The HHRC heavy hip-ridge connector attaches two 45-degree skewed roof hip members to the end of a ridge member. The U-shaped stirrups of the HHRC connectors support the roof hip members, and may be field-adjusted to a slope up to 45 degrees from the horizontal without adversely affecting the load-carrying capacity of the connector. The HHRC44 connectors are fabricated from No. 12 gage galvanized steel. See [Table 9](#) for the HHRC connector models, connector dimensions, required fasteners, and allowable loads. See [Figure 9](#) for drawings of the HHRC connectors and a typical installation.

3.2 Materials:

3.2.1 Steel: With the exception of the THAL/R hangers and HHRC connectors, all of the hangers and connectors described in this report are manufactured from galvanized steel complying with [ASTM A653](#), SS designation, Grade 33, with a minimum yield strength, F_y , of 33,000 psi (227 MPa) and a minimum tensile strength, F_u , of 45,000 psi (310 MPa). The THAL/R hangers and HHRC connectors are made with ASTM A653, SS designation, Grade 40, galvanized steel with a minimum yield strength of 40,000 psi (267 MPa) and a minimum tensile strength of 55,000 psi (379 MPa). The minimum base metal thicknesses for the hangers and connectors in this report are as follows:

NOMINAL THICKNESS (gage)	MINIMUM BASE-METAL THICKNESS (inch)
No. 12	0.0998
No. 14	0.0685
No. 16	0.0555
No. 18	0.0445

For SI: 1 inch = 25.4 mm.

The hangers and connectors have a minimum G90 zinc coating specification in accordance with ASTM A653. Some models (designated with a model number ending with Z) are available with a G185 zinc coating specification in accordance with ASTM A653. Some models (designated with a model number ending with HDG) are available with a hot-dip galvanization, also known as “batch” galvanization, in accordance with [ASTM A123](#), with a minimum specified coating weight of 2.0 ounces of zinc per square foot of surface area (600 g/m²), total for both sides. Model numbers in this report do not include the Z or HDG ending, but the information shown applies. The lumber treater or holder of this report (Simpson Strong-Tie Company) should be contacted for recommendations on minimum corrosion resistance of steel connectors in contact with the specific proprietary preservative treated or fire-retardant treated lumber.

3.2.2 Wood: Wood members with which the connectors are used must be either sawn lumber or engineered lumber having a minimum specific gravity of 0.50 (minimum equivalent specific gravity of 0.50 for engineered lumber), and having a maximum moisture content of 19 percent (16 percent for engineered lumber) except as noted in [Section 4.1](#). The thickness of the supporting wood member (header) must be equal to or greater than the length of the fasteners specified in the tables in this report, or as required by wood member design, whichever is greater.

3.2.3 Fasteners: Nails used for hangers described in this evaluation report must be bright or hot-dipped galvanized carbon steel nails complying with [ASTM F1667](#) as reference in [Section 2303.6](#) of the IBC. Alternatively, nails of other materials or finishes may be used when they are recognized in an ICC-ES evaluation report as having bending yield strength (F_{yb}) and withdrawal capacity equal to or better than those of a bright carbon steel nail of the same nominal diameter as required by this evaluation report as shown in the following table:

FASTENER	SHANK DIAMETER (inch)	LENGTH (inches)	F_{yb} (psi)
10d × 1½ common	0.148	1½	90,000
10d common	0.148	3	90,000
16d sinker	0.148	¾	90,000
16d × 2½ common	0.162	2½	90,000
16d common	0.162	¾	90,000

For SI: 1 inch = 25.4 mm, 1 psi = 6.895 kPa.

Fasteners used in contact with preservative-treated or fire-retardant-treated lumber must comply with Section [2304.10.6](#) of the 2021 IBC, Section [2304.10.5](#) of the 2018 or 2015 IBC, Section [2304.9.5](#) of the 2012 IBC or Section [R317.3](#) of the 2021, 2018, 2015, 2012 or 2009 IRC, as applicable. For use with treated lumber, the lumber treater or this report holder (Simpson Strong-Tie Company), or both should be contacted for recommendations on minimum corrosion resistance of fasteners and connection capacities of fasteners used with the specific proprietary preservative treated or fire-retardant treated lumber. Unless otherwise indicated, fasteners listed in this report as 10d and 16d are 10d common and 16d common nails, respectively.

HHRC connectors are attached to wood with Simpson Strong-Tie SD-Series screws described in [ESR-3046](#). For applications under the IBC, SD-Series screws may not be used in contact with preservative-treated or fire-retardant-treated wood, with exception that SD-series screws may be used with SBX/DOT and zinc borate preservative-treated wood in interior, dry environment. For applications under the IRC, the SD-Series screws may be used in contact with preservative-treated or fire-retardant-treated wood.

4.0 DESIGN AND INSTALLATION

4.1 Design:

The tabulated allowable loads shown in this report are based on allowable stress design (ASD) and include the load duration factor, C_D , corresponding with the applicable loads in accordance with the *National Design Specification*[®] for Wood Construction (NDS).

Tabulated allowable loads apply to products connected to wood used under dry conditions and where sustained temperatures are 100°F (37.8°C) or less. When products are installed to wood having a moisture content greater than 19 percent (16 percent for engineered wood products), or where wet service is expected, the allowable loads must be adjusted by the wet service factor, C_M , specified in the NDS. When connectors are installed in wood that will experience sustained exposure to temperatures exceeding 100°F (37.8°C), the allowable loads in this report must be adjusted by the temperature factor, C_t , specified in the NDS.

Connected wood members must be analyzed for load-carrying capacity at the connection in accordance with the NDS.

4.2 Installation:

Installation of the connectors must be in accordance with this evaluation report and the manufacturer's published installation instructions. In the event of a conflict between this report and the manufacturer's published installation instructions, this report governs.

5.0 CONDITIONS OF USE:

The Simpson Strong-Tie adjustable hangers and hip connectors described in this report comply with, or are suitable alternatives to what is specified in, those codes listed in Section [1.0](#) of this report, subject to the following conditions:

- 5.1 The connectors must be manufactured, identified and installed in accordance with this report and the manufacturer's published installation instructions. A copy of the instructions must be available at the jobsite at all times during installation.
- 5.2 Calculations showing compliance with this report must be submitted to the code official. The calculations must be prepared by a registered design professional where required by the statutes of the jurisdiction in which the project is to be constructed.

- 5.3 Adjustment factors noted in Section 4.1 and the applicable codes must be considered, where applicable.
- 5.4 Connected wood members and fasteners must comply, respectively, with Sections 3.2.2 and 3.2.3 of this report.
- 5.5 Use of connectors with preservative-treated or fire-retardant-treated lumber must be in accordance with Section 3.2.1 of this report. Use of fasteners with preservative-treated or fire-retardant-treated lumber must be in accordance with Section 3.2.3 of this report.

6.0 EVIDENCE SUBMITTED

Data in accordance with the ICC-ES Acceptance Criteria for Joist Hangers and Similar Devices (AC13), dated October 2018 (Editorially revised December 2020).

7.0 IDENTIFICATION

- 7.1 The ICC-ES mark of conformity, electronic labeling, or the evaluation report number (ICC-ES ESR-2551) along with the name, registered trademark, or registered logo of the report holder [and/or listee] must be included in the product label. [Electronic labeling is the ICC-ES web address (www.icc-es.org); specific URL related to the report; or the ICC-ES machine-readable code placed on the aforementioned items.]
- 7.2 In addition, the products described in this report are identified with a die-stamped label or an adhesive label, indicating the name of the manufacturer (Simpson Strong-Tie), the model number, and the number of an index evaluation report ([ESR-2523](#)) that is used as an identifier for the products recognized in this report.
- 7.3 The report holder’s contact information is the following:

SIMPSON STRONG-TIE COMPANY INC.
5956 WEST LAS POSITAS BOULEVARD
PLEASANTON, CALIFORNIA 94588
(800) 925-5099
www.strongtie.com

TABLE 1—HCP HIP CORNER PLATE CONNECTORS

MODEL NO.	JOIST/RAFTER SIZE	FASTENERS ¹ (Quantity – Type)		ALLOWABLE LOADS ^{2,3} (lbs)	
		Rafter	Top Plates	Uplift	Lateral F ₁
				C _D = 1.6	C _D = 1.6
HCP2	2x	6-10d x 1 1/2	6-10d x 1 1/2	590	255
HCP1.81	1 3/4"	6-10d x 1 1/2	6-10d x 1 1/2	590	255
HCP4	4x	8-10d	8-10d	990	230

For SI: 1 inch = 25.4 mm, 1 lbf = 4.5 N.

¹Refer to Figure 1b for typical HCP connector installation and location of required fasteners.

²Tabulated allowable loads must be selected based on duration of load as permitted by the applicable building code.

³The uplift loads have been increased for wind or earthquake loading with no further increase allowed. The allowable uplift loads must be reduced when other load durations govern.

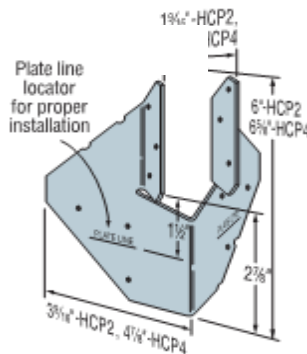

**FIGURE 1a—
HCP Connector
Dimensions**

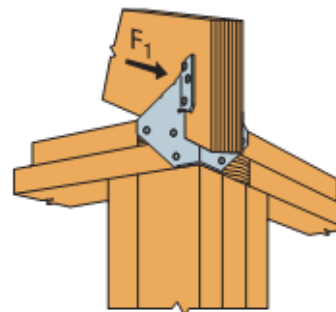

**FIGURE 1b—
HCP Connector
Installation and
Allowable Load
Directions
(See Table 1)**

FIGURE 1—HCP CONNECTORS

TABLE 2—HRC SERIES HIP/RIDGE CONNECTOR

MODEL NO.	RIDGE SIZE	HIP SIZE	FASTENERS (Quantity – Type)		ALLOWABLE LOADS ^{1,2,3} (lbs)			
			Ridge (Carrying Member)	Hip ⁴ (Carried Member)	Uplift	Download		
					C _D = 1.6	C _D = 1.0	C _D = 1.15	C _D = 1.25
HRC22	2x or 1 ³ / ₄ "	2x	16-10d x 1 ¹ / ₂	2-10d x 1 ¹ / ₂	370	975	1,105	1,185
HRC1.81	2x or 1 ³ / ₄ "	1 ³ / ₄ "	16-10d x 1 ¹ / ₂	2-10d x 1 ¹ / ₂	370	975	1,105	1,185

For SI: 1 inch = 25.4 mm, 1 lbf = 4.5 N.

¹Tabulated allowable loads must be selected based on duration of load as permitted by the applicable building code.

²The uplift loads have been increased for wind or earthquake loading with no further increase allowed. The allowable uplift loads must be reduced when other load durations govern.

³Total load carried by connector is shown. Allowable load for each hip is one half of the tabulated value.

⁴Number of fasteners shown is for each hip carried. Total number of fasteners to hips is double the tabulated quantity.

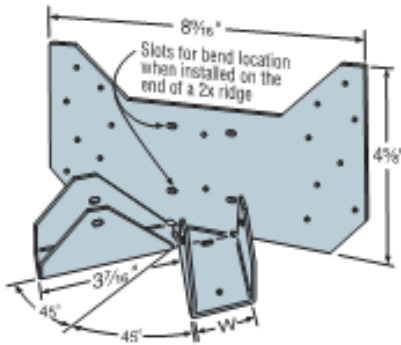

HRC22
(HRC1.81 Similar)

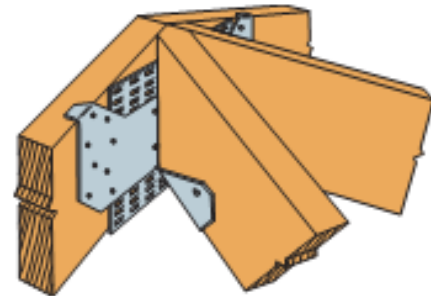

HRC22 Installed

FIGURE 2—HRC CONNECTORS

TABLE 3—LSU/LSSU SKEWED AND SLOPED HANGERS

MODEL NO.	HANGER ¹ DIMENSIONS (inches)			FASTENERS (Quantity – Type)			ALLOWABLE LOAD ² (lbs)						
	W	H	A	Header		Joist	Uplift ³ C _D =1.6	Download					
				Sloped Only ⁴	Skewed or Skewed & Sloped ⁵			Sloped Only				Skewed	
								C _D =1.0	C _D =1.15	C _D =1.25	C _D =1.0	C _D =1.15	C _D =1.25
LSU26	1 ⁹ / ₁₆	4 ⁷ / ₈	1 ¹ / ₂	6–10d	6–10d	5-10d x 1 ¹ / ₂	500	710	810	865	710	810	865
LSSU28	1 ⁹ / ₁₆	7 ¹ / ₈	1 ¹ / ₂	10–10d	9–10d	5-10d x 1 ¹ / ₂	370	1,180	1,350	1,450	855	855	855
LSSU210	1 ⁹ / ₁₆	8 ¹ / ₂	1 ⁵ / ₈	10–10d	9–10d	7-10d x 1 ¹ / ₂	645	1,180	1,350	1,450	1,060	1,100	1,100

For SI: 1 inch = 25.4 mm, 1 lbf = 4.5 N.

¹Refer to Figure 3 for definitions of hanger dimension nomenclature (W, H, A).

²Tabulated allowable loads must be selected based on duration of load as permitted by the applicable building code.

³The uplift loads have been increased for wind or earthquake loading with no further increase allowed. The allowable uplift loads must be reduced when other load durations govern.

⁴Maximum slope up or down is 45 degrees.

⁵The hanger may be skewed only or skewed and sloped. Maximum skew left or right is 45 degrees.

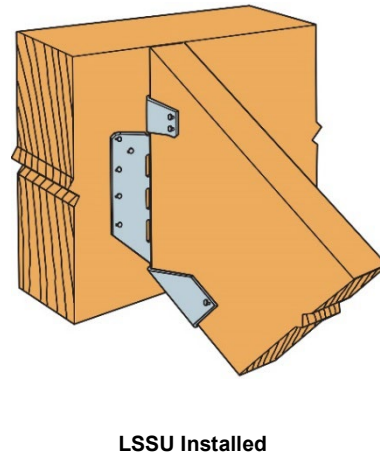
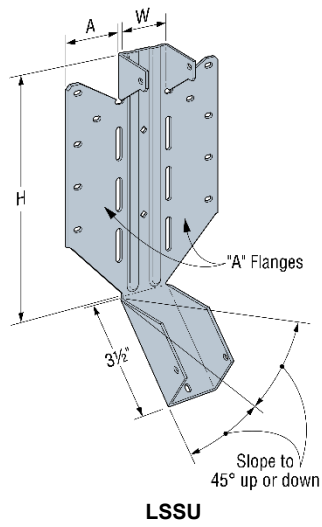
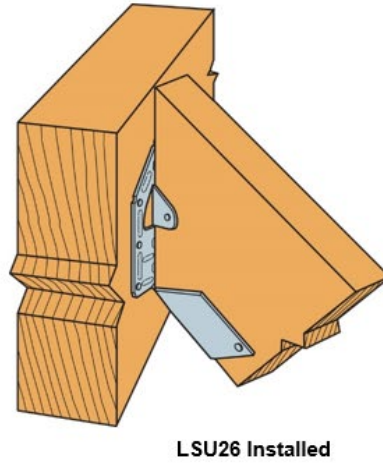
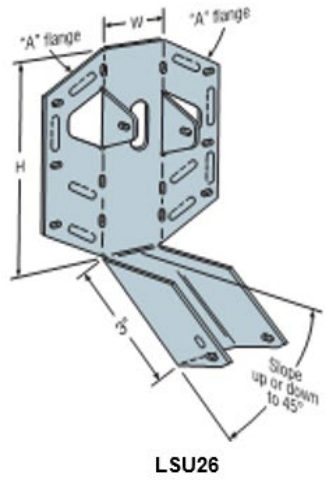

FIGURE 3—LSU/LSSU SKEWED AND SLOPED HANGERS

TABLE 4—THA SERIES TRUSS HANGERS ADJUSTABLE ⁸

MODEL NO.	DIMENSIONS ¹ (inches)			FASTENERS ² (Quantity – Type)				ALLOWABLE LOADS ^{3,4} (lbs)			
	W	H	C	Carrying Member		Carried Member		Uplift ⁴ C _D = 1.6	Download		
				Top	Face	Straight ⁵	Slant ⁶		C _D = 1.0	C _D = 1.15	C _D = 1.25
Minimum Nailing Schedule (Common Wire Nail Size)											
THA29	1 ⁵ / ₈	9 ¹¹ / ₁₆	5 ¹ / ₈	4-10d	6-10d	—	4-10d	465	2,560	2,560	2,560
THA213	1 ⁵ / ₈	13 ⁵ / ₁₆	5 ¹ / ₂	4-10d	2-10d	4-10d x 1 ¹ / ₂	—	—	1,430	1,430	1,430
				4-10d	6-10d	—	4-10d	855	2,090	2,090	2,090
THA218	1 ⁵ / ₈	17 ³ / ₁₆	5 ¹ / ₂	4-10d	2-10d	4-10d x 1 ¹ / ₂	—	—	1,430	1,430	1,430
				4-10d	6-10d	—	4-10d	855	2,090	2,090	2,090
THA218-2	3 ¹ / ₈	17 ¹¹ / ₁₆	8	4-16d	2-16d	6-10d	—	—	2,245	2,245	2,245
				4-16d	6-16d	—	6-16d	1,855	3,670	3,670	3,670
THA222-2	3 ¹ / ₈	22 ³ / ₁₆	8	4-16d	2-16d	6-10d	—	—	2,245	2,245	2,245
				4-16d	6-16d	—	6-16d	1,855	3,670	3,670	3,670
THA413	3 ⁵ / ₈	13 ⁵ / ₁₆	4 ¹ / ₂	4-10d	2-10d	4-10d	—	—	1,430	1,430	1,430
				4-10d	6-10d	—	4-10d	855	2,090	2,090	2,090
THA418	3 ⁵ / ₈	17 ¹ / ₂	7 ⁷ / ₈	4-16d	2-16d	6-10d	—	—	2,245	2,245	2,245
				4-16d	6-16d	—	6-16d	1,855	3,670	3,670	3,670
THAC418	3 ⁵ / ₈	17 ¹ / ₂	7 ⁷ / ₈	4-16d	2-16d	6-10d	—	—	2,245	2,245	2,245
				4-16d	6-16d	—	6-16d	1,855	3,670	3,670	3,670
THA422	3 ⁵ / ₈	22	7 ⁷ / ₈	4-16d	2-16d	6-10d	—	—	2,245	2,245	2,245
				4-16d	6-16d	—	6-16d	1,855	3,670	3,670	3,670
THAC422	3 ⁵ / ₈	22	7 ⁷ / ₈	4-16d	2-16d	6-10d	—	—	2,245	2,245	2,245
				4-16d	6-16d	—	6-16d	1,855	3,670	3,670	3,670
THA426	3 ⁵ / ₈	26	7 ⁷ / ₈	4-16d	4-16d	6-16d	—	—	2,870	2,870	2,870
				4-16d	6-16d	—	6-16d	1,855	3,755	3,755	3,755
THA422-2	7 ¹ / ₄	22 ¹¹ / ₁₆	9 ³ / ₄	4-16d	4-16d	6-16d	—	—	3,330	3,330	3,330
				4-16d	8-16d	—	6-16d	1,855	4,210	4,210	4,210
THA426-2	7 ¹ / ₄	26 ¹¹ / ₁₆	9 ³ / ₄	4-16d	4-16d	6-16d	—	—	3,330	3,330	3,330
				4-16d	8-16d	—	6-16d	1,855	4,210	4,210	4,210
Maximum Nailing Schedule (Common Wire Nail Size) ⁷											
THA29	1 ⁵ / ₈	9 ¹¹ / ₁₆	5 ¹ / ₈	—	16-10d	—	4-10d	465	2,280	2,305	2,305
THA213	1 ⁵ / ₈	13 ⁵ / ₁₆	5 ¹ / ₂	—	14-10d	—	4-10d	855	2,045	2,210	2,210
THA218	1 ⁵ / ₈	17 ³ / ₁₆	5 ¹ / ₂	—	18-10d	—	4-10d	855	2,210	2,210	2,210
THA218-2	3 ¹ / ₈	17 ¹¹ / ₁₆	8	—	22-16d	—	6-16d	1,855	3,695	3,695	3,695
THA222-2	3 ¹ / ₈	22 ³ / ₁₆	8	—	22-16d	—	6-16d	1,855	3,695	3,695	3,695
THA413	3 ⁵ / ₈	13 ⁵ / ₁₆	4 ¹ / ₂	—	14-10d	—	4-10d	855	2,045	2,210	2,210
THA418	3 ⁵ / ₈	17 ¹ / ₂	7 ⁷ / ₈	—	22-16d	—	6-16d	1,855	3,695	3,695	3,695
THAC418	3 ⁵ / ₈	17 ¹ / ₂	7 ⁷ / ₈	—	22-16d	—	6-16d	1,855	3,695	3,695	3,695
THA422	3 ⁵ / ₈	22	7 ⁷ / ₈	—	22-16d	—	6-16d	1,855	3,695	3,695	3,695
THAC422	3 ⁵ / ₈	22	7 ⁷ / ₈	—	22-16d	—	6-16d	1,855	3,695	3,695	3,695
THA426	3 ⁵ / ₈	26	7 ⁷ / ₈	—	30-16d	—	6-16d	1,855	4,315	4,315	4,315
THA422-2	7 ¹ / ₄	22 ¹¹ / ₁₆	9 ³ / ₄	—	30-16d	—	6-16d	1,855	5,170	5,520	5,520
THA426-2	7 ¹ / ₄	26 ¹¹ / ₁₆	9 ³ / ₄	—	38-16d	—	6-16d	1,855	5,520	5,520	5,520

For SI: 1 inch = 25.4 mm, 1 lbf = 4.5 N.

¹Refer to Figure 4 for definitions of hanger dimension nomenclature (W, H, C).

²There are two nailing configurations:

- a. Minimum Nailing Schedule: The hanger straps must be field formed (bent) over the top of the carrying member as described in Section 3.1.4 of this report and nailed as specified in the table.
- b. Maximum Nailing Schedule: The hanger straps may be bent over the top of the header or straight up the face of the header and nailed as specified in the table. Nails for the bent portion of the strap into top of carrying member must be considered additional to those required in the table for the face.

³Tabulated allowable load capacities must be selected based on duration of load as permitted by the applicable building code.

⁴The uplift loads have been increased for wind or earthquake loading with no further increase allowed. The allowable uplift loads must be reduced when other load durations govern.

⁵Straight nailing must use nails driven straight (perpendicular) into the joist or truss.

⁶Slant nailing is where nails are driven at a 45-degree angle through the joist and into the header, which is described as double shear nailing in the installation instructions and shown in Figure 4.

⁷For maximum nailing, the 16d sinker nails are permitted to be used to replace the 16d common, provided the design loads noted in the table are multiplied by a factor of 0.85.

⁸Connectors have not been evaluated for torsional resistance. Where lateral and torsional restraint is required by member design or applicable code, it must be provided by other means.

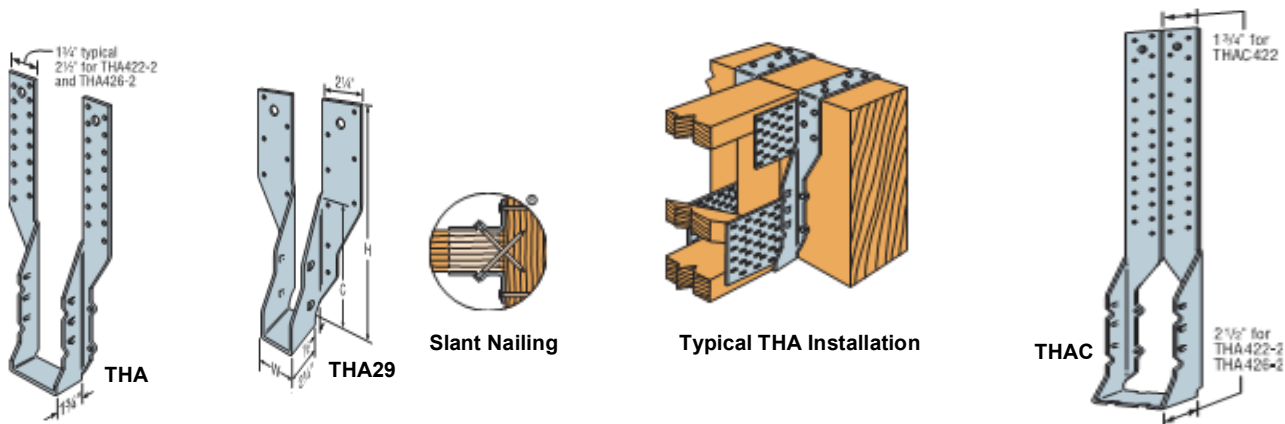

FIGURE 4—THA SERIES TRUSS HANGERS ADJUSTABLE

TABLE 5A—THAI ADJUSTABLE I-JOIST HANGER DIMENSIONS

MODEL NO.	JOIST DIMENSIONS (inches)		HANGER DIMENSIONS ¹ (inches)			
	Width	Depth		W	H	C
		Minimum	Maximum			
THAI222	1 1/2	9 1/4	14	1 ⁹ / ₁₆	22 ⁷ / ₈	9 ³ / ₈
THAI1.81/22	1 ³ / ₄	9 1/4	14	1 ¹³ / ₁₆	22 ³ / ₄	9 ¹ / ₄
THAI2.06/22	2	9 1/4	14	2 ¹ / ₁₆	22 ⁵ / ₈	9 ¹ / ₈
THAI2.1/22	2 ¹ / ₁₆	9 1/4	14	2 ¹ / ₈	22 ⁹ / ₁₆	9 ¹ / ₈
THAI3522	2 ¹ / ₄ (min), 2 ⁵ / ₁₆ (max)	9 1/4	14	2 ⁵ / ₁₆	22 ¹ / ₂	9
THAI322	2 1/2	9 1/4	14	2 ⁹ / ₁₆	22 ³ / ₈	8 ⁷ / ₈
THAI422	3 1/2	9 1/4	14	3 ⁹ / ₁₆	21 ⁷ / ₈	8 ³ / ₈

For SI: 1 inch = 25.4 mm.

¹Refer to Figure 5 (this page) for definitions of hanger nomenclature (W, H, C).

TABLE 5B—THAI ADJUSTABLE I-JOIST HANGER FASTENER SCHEDULE AND ALLOWABLE LOADS¹

MODEL NO.	NAILING CONFIGURATION	FASTENERS ² (Quantity – Type)			ALLOWABLE LOAD ³ (lbs)			
		Header		Joist	Uplift ^{4,5} C _D = 1.6	Download		
		Top	Face			C _D = 1.0	C _D = 1.15	C _D = 1.25
THAI	Minimum ⁶	4-10d	2-10d	2-10d x 1 1/2	—	1,735	1,735	1,735
		4-10d x 1 1/2	2-10d x 1 1/2	2-10d x 1 1/2	—	1,325	1,325	1,325
	Maximum ⁷	—	20-10d	2-10d x 1 1/2	185	2,080	2,080	2,080

For SI: 1 inch = 25.4 mm, 1 lbf = 4.5 N.

¹The hangers must be used with prefabricated wood I-joists with web stiffeners. The lesser allowed load values of the THAI connector values in the table or the allowable capacity of the value of the prefabricated wood I-joist listed in the applicable ICC-ES evaluation report, must govern.

²16d sinkers (0.148-inch shank diameter by 3 1/4 inches long) are permitted to replace 10d common nails (0.148-inch shank diameter by 3 inches long).

³Tabulated allowable loads must be selected based on duration of load as permitted by the applicable building code.

⁴The uplift loads have been increased for wind or earthquake loading with no further increase allowed. The allowable uplift loads must be reduced when other load durations govern.

⁵To achieve the tabulated allowable uplift load, a minimum of two 10d nails must be installed into the face of the carrying member.

⁶The minimum nailing configuration is shown in Figure 5a for top nailing installations. The strap must be field-formed over the top of the header by a minimum of 2 1/2 inches.

⁷The maximum nailing configuration requires the carrying beam/header to have a minimum depth of 16 inches and all 20-10d nails installed into the face of the carrying beam/header. The allowable download must be reduced by the allowable nail shear capacity for each nail less than maximum.

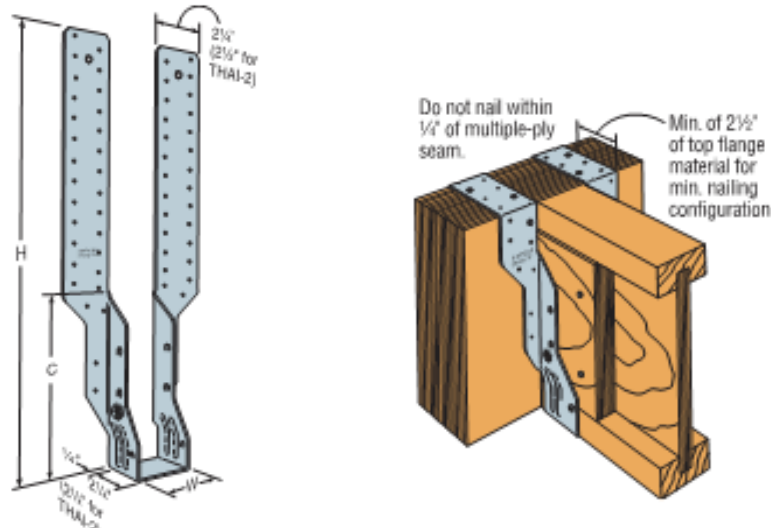

Figure 5a—
Typical THAI Hanger
Installation with
Minimum Nailing
Configuration
(See Table 5B)

FIGURE 5—THAI ADJUSTABLE I-JOIST HANGER

TABLE 6—THAL/R422 (FACTORY SKEWED 45°) ADJUSTABLE TRUSS HANGER

MODEL NO.	HANGER DIMENSIONS (inches)			FASTENERS (Quantity – Type)				ALLOWABLE LOADS ¹ (lbs)			
				Carrying Member		Carried Member		Uplift ²		Download ³	
	Seat Width (W)	Hanger Height (H)	Joist Nailing Height (C)	Top	Face	Straight	Slant ⁴	C _D = 1.6	C _D = 1.0	C _D = 1.15	C _D = 1.25
THAL422 and THAR422	3 ⁵ / ₈	22 ⁵ / ₈	8	4–10d	2–10d	1–10d	2–10d x 1 ¹ / ₂	---	1,050	1,050	1,050
				4–10d	12–10d	1–10d	2–10d x 1 ¹ / ₂	265	1,640	1,730	1,730

For SI: 1 inch = 25.4 mm, 1 lbf = 4.5 N.

¹Tabulated allowable loads must be selected based on duration of load as permitted by the applicable building code.

²The uplift loads have been increased for wind or earthquake loading with no further increase allowed. The allowable uplift loads must be reduced when other load durations govern.

³There are two different installation methods. The minimum nailing installation has 10 fewer face nails than the maximum nailing installation. For each method the straps are field formed over the top of the carrying member a minimum of 2¹/₂ inches (4 mm) and nailed to the top and face of the carrying member with the quantity of 10d common nails shown in the table.

⁴Slant nailing are nails driven at a 45-degree angle through the joist and into the header, which is described as double shear nailing in the installation instructions and shown in [Figure 4](#) of this report.

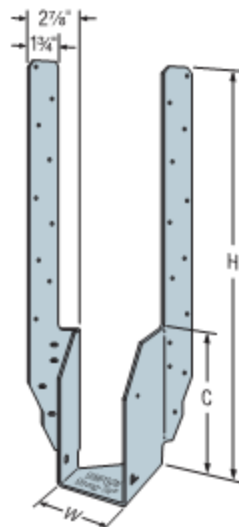

FIGURE 6—THAL/R422 HANGER

TABLE 7—VPA VARIABLE PITCH CONNECTORS

MODEL NO.	CONNECTOR WIDTH (W) (inches)	FASTENERS (Quantity - Type)		ALLOWABLE LOAD ¹ (lbs)			
		Plates	Joist	Uplift ²	Download		
				C _D = 1.6	C _D = 1.0	C _D = 1.15	C _D = 1.25
VPA2	1 ⁹ / ₁₆	8-10d	4-10d x 1 ¹ / ₂	255	1,105	1,105	1,105
VPA25	1 ¹³ / ₁₆	8-10d	4-10d x 1 ¹ / ₂	255	1,105	1,105	1,105
VPA3	2 ⁹ / ₁₆	9-10d	4-10d x 1 ¹ / ₂	255	1,245	1,245	1,245
VPA35	2 ⁵ / ₁₆	9-10d	4-10d x 1 ¹ / ₂	255	1,245	1,245	1,245
VPA4	3 ⁹ / ₁₆	11-10d	4-10d x 1 ¹ / ₂	255	1,245	1,245	1,245

For SI: 1 inch = 25.4 mm, 1 lbf = 4.5 N.

¹Tabulated allowable loads must be selected based on duration of load as permitted by the applicable building code.

²The uplift loads have been increased for wind or earthquake loading with no further increase allowed. The allowable uplift loads must be reduced when other load durations govern.

³Connectors must not be substituted for blocking to provide lateral stability or prevent rotation.

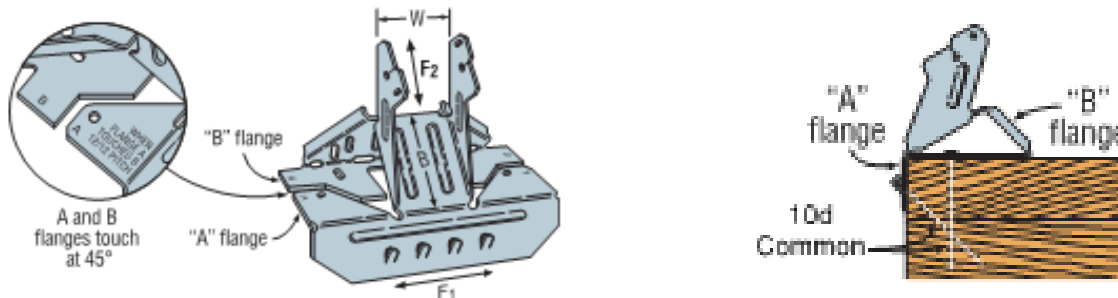

FIGURE 7—VPA VARIABLE PITCH CONNECTOR

TABLE 8—ALLOWABLE LOADS FOR THE LRUZ SERIES HANGERS

MODEL NO.	HANGER DIMENSIONS ¹ (inches)				FASTENERS (Quantity - Type)		ALLOWABLE LOADS ² (lbs.)			
	W	H	B	Max. C ₁	Face	Joist ³	Uplift ³	Download		
							C _D = 1.60	C _D = 1.00	C _D = 1.15	C _D = 1.25
LRU26Z	1 ⁹ / ₁₆	5 ¹ / ₄	1 ¹⁵ / ₁₆	1 ³ / ₄	4-10d	5-10d	600	865	990	990
					4-16d	5-16d	810	1,030	1,175	1,275
LRU28Z	1 ⁹ / ₁₆	6 ¹⁵ / ₁₆	1 ¹⁵ / ₁₆	2 ⁵ / ₈	6-10d	5-10d	805	1,050	1,050	1,050
					6-16d	5-16d	810	1,315	1,340	1,340
LRU210Z	1 ⁹ / ₁₆	8 ³ / ₁₆	1 ¹⁵ / ₁₆	1 ³ / ₄	6-10d	7-10d	1,015	1,295	1,480	1,495
					6-16d	7-16d	1,015	1,550	1,620	1,620
LRU212Z	1 ⁹ / ₁₆	10 ¹¹ / ₁₆	1 ¹⁵ / ₁₆	3 ¹ / ₂	6-10d	7-10d	1,305	1,295	1,430	1,430
					6-16d	7-16d	1,305	1,550	1,765	1,910

For SI: 1 inch = 25.4 mm, 1 lbf = 4.45 N.

¹Refer to Figure 8 (this page) for definitions of hanger nomenclature (W, H, B, C₁).

²Tabulated allowable loads must be selected based on duration of load as permitted by the applicable building code.

³The uplift loads have been increased for wind or earthquake loading with no further increase allowed. The allowable uplift loads must be reduced when other load durations govern.

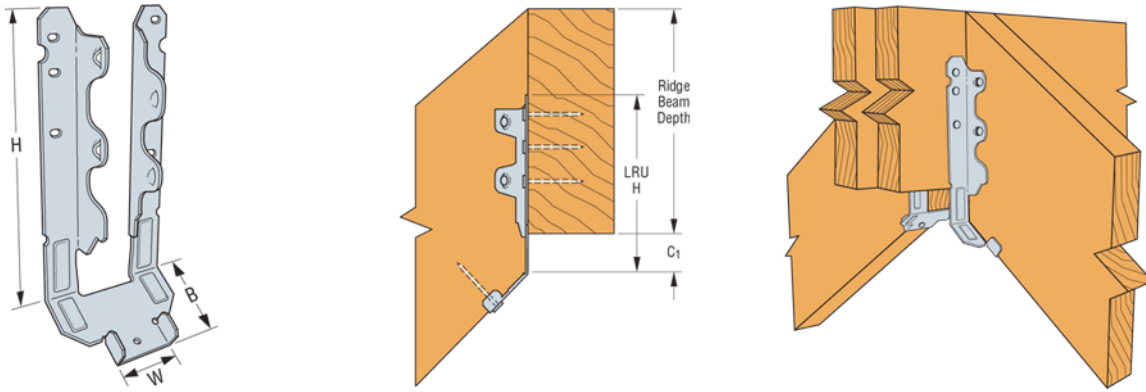

FIGURE 8—LRUZ HANGER AND TYPICAL INSTALLATIONS

TABLE 9—ALLOWABLE LOADS FOR THE HHRC SERIES HANGERS^{1,2}

MODEL NO.	CONNECTION MEMBERS (in.)		CONNECTOR WIDTH (in.)		FASTENERS ³ (Quantity – Type)		ALLOWABLE LOAD PER HIP (lbs)	
	Ridge	Hip	Ridge (W ₁)	Hip (W ₂)	Ridge	Hip	Download (100/115/125)	Uplift (160)
HHRC2-2	3	3	3 ¹ / ₈	3 ¹ / ₈	(40) SD10212	(22) SD10212	3,110	1,490
HHRC42	3 ¹ / ₂	1 ¹ / ₂	3 ⁵ / ₈	1 ⁹ / ₁₆	(40) SD10212	(22) SD10112	3,110	1,490
HHRC42-2	3 ¹ / ₂	3	3 ⁵ / ₈	3 ¹ / ₈	(40) SD10212	(22) SD10212	3,110	1,970
HHRC4/1.81	3 ¹ / ₂	1 ³ / ₄	3 ⁵ / ₈	1 ¹³ / ₁₆	(40) SD10212	(22) SD10112	3,110	1,490
HHRC44	3 ¹ / ₂	3 ¹ / ₂	3 ⁵ / ₈	3 ⁵ / ₈	(40) SD10212	(22) SD10212	3,110	1,970
HHRC5.25/3.25	5 ¹ / ₈	3 ¹ / ₈	5 ¹ / ₄	3 ¹ / ₄	(40) SD10212	(22) SD10212	3,110	1,970
HHRC5.37/3.12	5 ¹ / ₄	3	5 ¹ / ₄	3 ¹ / ₄	(40) SD10212	(22) SD10212	3,110	1,970
HHRC66	5 ¹ / ₂	5 ¹ / ₂	5 ⁵ / ₈	5 ⁵ / ₈	(40) SD10212	(27) SD10212	3,110	1,970

For SI: 1 inch = 25.4 mm, 1 lbf = 4.45 N

¹Allowable loads shown are for each hip. Total load carried at the ridge is 2x the load listed.

²Uplift loads include an increase for wind and earthquake loading with no further increase allowed; reduce where other loads govern.

³Fasteners are SD10212 with diameter of 0.162 inch by 2.5 inches long Strong-Drive Screws (provided) recognized in [ESR-3046](#).

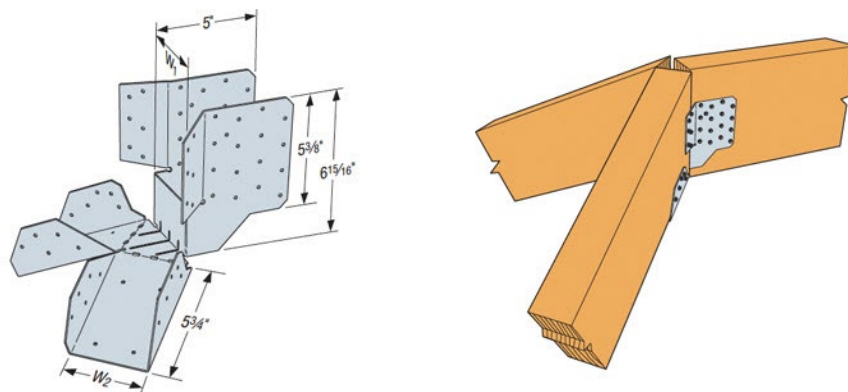

FIGURE 9—HHRC HANGER AND TYPICAL INSTALLATIONS

DIVISION: 06 00 00—WOOD, PLASTICS AND COMPOSITES
Section: 06 05 23—Wood, Plastic, and Composite Fastenings

REPORT HOLDER:

SIMPSON STRONG-TIE COMPANY INC.

EVALUATION SUBJECT:

SIMPSON STRONG-TIE® ADJUSTABLE HANGERS AND HIP CONNECTORS FOR WOOD FRAMING

1.0 REPORT PURPOSE AND SCOPE**Purpose:**

The purpose of this evaluation report supplement is to indicate that the Simpson Strong-Tie adjustable hangers and hip connectors for wood framing, described in ICC-ES evaluation report [ESR-2551](#), have also been evaluated for compliance with the codes noted below as adopted by the Los Angeles Department of Building and Safety (LADBS).

Applicable code editions:

- 2023 *City of Los Angeles Building Code* ([LABC](#))
- 2023 *City of Los Angeles Residential Code* ([LARC](#))

2.0 CONCLUSIONS

The Simpson Strong-Tie adjustable hangers and hip connectors for wood framing, described in Sections 2.0 through 7.0 of the evaluation report [ESR-2551](#), comply with the LABC Chapter 23, and the LARC, and are subjected to the conditions of use described in this supplement.

3.0 CONDITIONS OF USE

The Simpson Strong-Tie adjustable hangers and hip connectors for wood framing, described in this evaluation report supplement, must comply with all of the following conditions:

- All applicable sections in the evaluation report [ESR-2551](#).
- The design, installation, conditions of use and labeling are in accordance with the 2021 International Building Code® (IBC) provisions noted in the evaluation report [ESR-2551](#).
- The design, installation and inspection are in accordance with additional requirements of LABC Chapter 23.
- The supported end of joist or beam must be within 1/4-inch from the supporting member.
- Solid blocking must be required for all joist hangers supporting roof joists having one end twisted more than one-half degree per foot of length relative to the other end, except as specifically noted in the evaluation report.
- Allowable loads must be reduced when a load duration with a lower value of C_d (than what is in the tables) governs.
- Under the LARC, an engineered design in accordance with LARC Section R301.1.3 must be submitted.

This supplement expires concurrently with the evaluation report ESR-2551, reissued January 2025.

DIVISION: 06 00 00—WOOD, PLASTICS AND COMPOSITES
Section: 06 05 23—Wood, Plastic, and Composite Fastenings

REPORT HOLDER:

SIMPSON STRONG-TIE COMPANY INC.

EVALUATION SUBJECT:

SIMPSON STRONG-TIE® ADJUSTABLE HANGERS AND HIP CONNECTORS FOR WOOD FRAMING

1.0 REPORT PURPOSE AND SCOPE**Purpose:**

The purpose of this evaluation report supplement is to indicate that the Simpson Strong-Tie adjustable hangers and hip connectors for wood framing, described in ICC-ES evaluation report ESR-2551, have also been evaluated for compliance with the codes noted below.

Applicable code editions:

- 2023 *Florida Building Code—Building*
- 2023 *Florida Building Code—Residential*

2.0 CONCLUSIONS

The Simpson Strong-Tie adjustable hangers and hip connectors, described in Sections 2.0 through 7.0 of ICC-ES evaluation report ESR-2551, comply with the *Florida Building Code—Building*, and the *Florida Building Code—Residential*. The design requirements must be determined in accordance with the *Florida Building Code—Building* or the *Florida Building Code—Residential*, as applicable. The installation requirements noted in ICC-ES evaluation report ESR-2551 for the 2021 *International Building Code*® meet the requirements of the *Florida Building Code—Building* or the *Florida Building Code—Residential*, as applicable.

Use of the Simpson Strong-Tie adjustable hangers and hip connectors has also been found to be in compliance with the High-Velocity Hurricane Zone provisions of the *Florida Building Code—Building*, and the *Florida Building Code—Residential* with following condition:

- a. For connections subject to uplift, the connection must be designed for no less than 700 pounds (3114 N).

For products falling under Florida Rule 61G20-3, verification that the report holder's quality assurance program is audited by a quality assurance entity approved by the Florida Building Commission for the type of inspections being conducted is the responsibility of an approved validation entity (or the code official when the report holder does not possess an approval by the Commission).

This supplement expires concurrently with the evaluation report ESR-2551, reissued January 2025.