

# ICC-ES Evaluation Report

**ESR-2631**

Reissued June 2024

Revised April 2025

Subject to renewal June 2025

This report also contains:

- CBC Supplement

- LABC Supplement

ICC-ES Evaluation Reports are not to be construed as representing aesthetics or any other attributes not specifically addressed, nor are they to be construed as an endorsement of the subject of the report or a recommendation for its use. There is no warranty by ICC Evaluation Service, LLC, express or implied, as to any finding or other matter in this report, or as to any product covered by the report.

Copyright © 2025 ICC Evaluation Service, LLC. All rights reserved.

<p><b>DIVISION: 09 00 00— FINISHES</b></p> <p><b>Section: 09 22 26— Suspension Systems</b></p> <p><b>Section: 09 53 00— Acoustical Ceiling Suspension Assemblies</b></p>	<p><b>REPORT HOLDER:</b></p> <p><b>ROXUL USA INC. d/b/a ROCKFON</b></p>	<p><b>EVALUATION SUBJECT:</b></p> <p><b>ROCKFON® CHICAGO METALLIC™ SUSPENDED CEILING FRAMING SYSTEMS AND SUSPENDED CEILING SYSTEMS</b></p>	
--	---	--	---

## 1.0 EVALUATION SCOPE

Compliance with the following codes:

- 2021, 2018, 2015, 2012, 2009 and 2006 [International Building Code® \(IBC\)](#)
- 2013 *Abu Dhabi International Building Code (ADIBC)*<sup>†</sup>

<sup>†</sup>The ADIBC is based on the 2009 IBC. 2009 IBC code sections referenced in this report are the same sections in the ADIBC.

For evaluation for compliance with codes adopted by [Los Angeles Department of Building and Safety \(LADBS\)](#), see [ESR-2631 LABC Supplement](#).

For evaluation for compliance with codes adopted by the California Office of Statewide Health Planning and Development (OSHPD) AKA: California Department of Health Care Access and Information (HCAI) and Division of the State Architect (DSA), see [ESR-2631 CBC Supplement](#).

Property evaluated:

- Structural
- Interior Finish

## 2.0 USES

The ROCKFON® CHICAGO METALLIC™ suspended ceiling framing systems described in this report are recognized for use as framing systems of suspended ceiling assemblies in non-fire-resistance-rated construction applications. The ROCKFON® CHICAGO METALLIC™ suspended ceiling systems described in this report are recognized for use as suspended ceiling assemblies in non-fire-resistance-rated construction applications.

## 3.0 DESCRIPTION

**3.1 ROCKFON® CHICAGO METALLIC™ Suspended Ceiling Framing Systems (for Systems Described in Sections 4.1 through 4.3):**

**3.1.1 ROCKFON® CHICAGO METALLIC™ Acoustical Tile Ceiling Framing Systems (for Systems Described in Sections 4.1 and 4.2):** The ROCKFON® CHICAGO METALLIC™ acoustical tile ceiling framing systems are exposed ceiling framing systems consisting of main runner and cross tee framing members used with lay-in acoustical tiles. Main runners and cross tees for the acoustical tile ceiling framing systems addressed in Section 3.1.1 are described in [Table 1](#).

The 730 and 830 systems utilize cross tees with hook-in style end tabs that connect the cross tees together through slots in the main runners. The 730 and 830 systems require the use of No. 416 stainless steel wire clips and No. 415 carbon steel wire clips, respectively, at all cross tee/main runner intersections for use in Seismic Design Categories C, D, E and F and Seismic Design Categories D, E and F, respectively.

The 1200, 1250, and 1260 systems utilize cross tees with stake-on style end tabs that connect the cross tees together through slots in the main runners. The 1200 series cross tees are used in combination with the 200 series main runners. The 1250 series cross tees are used in combination with the 250 and 270 main runners. The 1260 cross tees are used in combination with the 260 and 280 main runners and have aluminum capped flanges.

The 1800, 1830, 1850 and 1860 systems utilize cross tees with integral end tabs formed from the base metal of the cross tee that connect the cross tees together through slots in the main runners. The 1830 and 1860 series components have aluminum capped flanges.

The 3500, 3550 and 3600 systems have a channel-shaped flange with a longitudinal regress measuring  $\frac{1}{4}$ ,  $\frac{1}{4}$ , and  $\frac{1}{8}$  inch (6.35, 6.35 and 3.175 mm) wide, respectively. Cross tees utilize integral end tabs formed from the base metal of the cross tee that connect the cross tees together through slots in the main runners.

The 3700 and 3800 systems have a tee-shaped flange with a  $\frac{3}{16}$ -inch (4.76 mm) longitudinal regress. Cross tees utilize integral end tabs formed from the base metal of the cross tee that connect the cross tees together through slots in the main runners.

The 4000 and 4050 systems utilize cross tees with stake-on style end tabs that connect the cross tees together through slots in the main runners.

The 4500, 4550 and 4600 systems have a channel-shaped flange with a longitudinal regress measuring, respectively,  $\frac{1}{4}$  inch (6.4 mm),  $\frac{1}{4}$  inch (6.4 mm) and  $\frac{1}{8}$  inch (3.2 mm). Cross tees utilize the stake-on style end tabs that connect with slots in the main runners.

The main runners and cross runners are manufactured from galvanized steel except the 730 series main runners and cross tees are manufactured from stainless steel and the 830 series main runners and cross tees are manufactured from aluminum.

**3.1.2 ROCKFON® CHICAGO METALLIC™ Drywall Furring Systems (for Systems Described in Section 4.3 and for 660C System Used Per Section 4.2):** The ROCKFON® CHICAGO METALLIC™ drywall suspended ceiling systems consist of furring runner and furring tee framing members for use with gypsum wallboard screw-attached to the bottom of the framing. Furring runners and furring tees for the drywall furring systems addressed in Section 3.1.2 are described in [Table 1](#).

The 640C and 650C systems utilize furring tees with hook-in style end tabs that connect the furring tees together through slots in the furring runners. The 640C system consists of 640C furring runners and a combination of 643C and 644C furring tees. The 650C system consists of 650C furring runners and a combination of 653C and 654C furring tees. The 660C and 670C systems utilize furring tees with stake-on style end tabs that connect the furring tees together through slots in the furring runners. The 660C system consists of 640C furring runners and a combination of 663C, 664C, 664C01A and 668C furring tees. The 670C system consists of 650C furring runners and a combination of 673C and 674C furring tees.

In addition to supporting screw-attached gypsum panels, the 660C system, comprised of the 640C furring runners and a combination of 663C, 664C, 664C01A and 668C furring tees and the 1274 cross tee, may be used as an exposed grid system to support lay-in ceiling panels in Seismic Design Categories (SDCs) C, D, E and F, provided the ceiling system complies with Section 4.2.1 (for SDC D, E or F) or Section 4.2.2 (For SDC C), and framing member requirements noted in this paragraph.

**3.1.3 Materials:** For systems described in Sections 3.1.1 and 3.1.2, the main runners, cross tees, furring runners and furring tees, including the cross sectional dimensions, lengths and allowable transverse loads, are described in [Table 1](#) of this report. All main runners and furring runners are classified in [Table 1](#) as light, intermediate or heavy-duty in accordance with ASTM C635.

Except for the 4500 and 4600 series main runners and cross tees, steel main runners, cross tees, furring runners and furring tees are roll-formed from ASTM A653 CS Type B steel. The 4500 and 4600 series main runners and cross tees are roll-formed ASTM A1008 CS Type B steel. The steel has either a galvanized or a proprietary coating, with all exposed surfaces given a polyester paint finish. Aluminum caps on steel framing members also have a polyester paint finish.

The stainless steel main runners and cross tees are roll-formed from AISI 304 stainless steel.

Aluminum main runners, cross tees, furring runners and furring tees are roll-formed from 3003-H14 or 3105-H14 aluminum complying with ASTM B209. The aluminum is provided with a factory-applied paint finish.

Cross tee stake-on end tabs are manufactured using either AISI 201 or 301 stainless steel or ASTM A1011 high strength low alloy (HSLA) steel with a G30 hot-dipped galvanized coating, or a proprietary coating.

**3.1.4 Hanger and Bracing Wires:** Wires for ROCKFON® CHICAGO METALLIC™ suspended ceiling framing members, and fixtures, must comply with ASTM C636 as referenced in 2021, 2018, 2015, 2012 and 2009 IBC Section 808 [2006 IBC Section 803.9] and Section 13.5.6 of ASCE 7 as referenced in IBC Sections 1613 and 2506.2.1.

**3.1.5 Accessories:** Each ROCKFON® CHICAGO METALLIC™ suspended ceiling system is provided with the necessary accessories, such as wall angles and molding, in order to meet the installation requirements.

### **3.2 ROCKFON® CHICAGO METALLIC™ Suspended Ceiling Systems (for Systems Described in Section 4.4):**

**3.2.1 Metaline Ceiling System:** The Metaline ceiling system is a direct-hung, exposed ceiling assembly consisting of main runners, cross runners (cross tees), and metal ceiling panels.

Aluminum main runners of model 10-00-830 are used with aluminum cross runners of models 10-00-834 and/or 10-00-832, and steel main runners of model 55-39-112 are used with steel cross runners of models 55-39-004 and/or 55-39-002. Runners 10-00-834 and 10-00-832 are identical except that 10-00-834 tee is 4 feet (1219 mm) long, while 10-00-832 tee is 2 feet (610 mm) long. Runners 55-39-004 and 55-39-002 are identical except that 55-39-004 tee is 4 feet (1219 mm) long, while 55-39-002 tee is 2 feet (610 mm) long. These main and cross runners feature a vertical web ending in a T-shape at one end and a bulb at the other end.

The steel ceiling panels measure 24 inches by 24 inches (610 mm by 610 mm) and 24 inches by 48 inches (610 mm by 1219 mm). Available in No. 16 gage [0.0598 inch (1.52 mm)], No. 18 gage [0.0478 inch (1.21 mm)], and No. 20 gage [0.0359 inch (0.91 mm)] thicknesses, the panels have edges bent at right angles and have perforations throughout. Aluminum panels are 0.040 inch (1 mm) thick, measure 24 inches by 24 inches (610 mm by 610 mm) and 24 inches by 48 inches (610 mm by 1219 mm).

**3.2.2 Planostile Ceiling System:** The Planostile ceiling system is a direct-hung, exposed ceiling assembly consisting of main runners, cross runners (cross tees), and metal ceiling panels.

Steel model MA010.500CH main runners feature a vertical web ending in a double Z-shape at one end and a bulb at the other end. Steel cross runner models include the 24-inch-long (610 mm) 10-04-022-C and the 48-inch-long (1219 mm) 10-04-024-C.

The ceiling panels measure 12 inches by 24 inches (305 mm by 610 mm), 24 inches by 24 inches (610 mm by 610 mm), 24 inches by 48 inches (610 mm by 1219 mm), and 20 inches by 60 inches (508 mm by 1524 mm). Available in No. 24 gage [0.0239 inch (0.61 mm)] and No. 25 gage [0.0209 inch (0.53 mm)] thicknesses, the panels have ridged edges bent at right angles and may either be perforated in various patterns or be smooth.

**3.2.3 Magna T-Cell Ceiling System:** The Magna T-cell ceiling system is a direct-hung, exposed ceiling assembly consisting of main runners, cross runners (cross tees), and metal web covers installed without ceiling tiles (or an open cell ceiling system).

Steel main runner models include 10-04-000-C with a steel cap and 10-04-000-AC with an aluminum cap. Steel cross runner models include 10-04-014-C, 10-04-022-C and 10-04-024-C with steel caps; and 10-04-014-AC, 10-04-022-AC and 10-04-024-AC that are identical as 10-04-014-C, 10-04-022-C and 10-04-024-C, respectively, except having aluminum caps. Runners 10-04-022-C and 10-04-024-C are identical except that 10-04-024-C tee is 4 feet (1219 mm) long, while 10-04-022-C tee is 2 feet (610 mm) long. These runners feature a vertical web ending in a T-shape at one end and a bulb at the other end.

Steel web cover models include 24-inch-long (610 mm) 38-40-907 and 38-40-908; 48-inch-long (1219 mm) 38-40-909 and 38-40-910. Aluminum web cover models include 24-inch-long (610 mm) 48-40-907 and 48-40-908; 48-inch-long (1219 mm) 48-40-909 and 48-40-910. These U-shaped covers are 2 inches (51 mm) high by  $\frac{5}{16}$  inch (7.9 mm) wide, having a thickness of 0.010 inch (0.25 mm) for steel covers, and 0.012 inch (0.31 mm) for aluminum covers.

### **3.2.4 Materials:**

**3.2.4.1 Metaline Ceiling system:** The steel main runners and cross runners are cold-formed from galvanized steel conforming to ASTM A653, CS, Type B. Aluminum main and cross runners are cold-formed from aluminum conforming to ASTM B209 Type 3003-H14. See [Table 2](#).

Aluminum ceiling panels comply with ASTM B209 Type 3003-H14. Steel ceiling panels conform to ASTM A653, CS, Type B and are hot-dipped galvanized with a G40 coating designation and have a painted finish.

**3.2.4.2 Planostile Ceiling System:** The main runners are cold-formed from galvanized steel conforming to EN10346-DX51D+Z1000. The cross runners are cold-formed from galvanized steel conforming to ASTM A653, CS, Type B. See [Table 2](#).

Aluminum ceiling panels comply with ASTM B209 Type 3003-H14. Steel ceiling panels conform to ASTM A653, CS, Type B and are hot-dipped galvanized with a G40 coating designation and have a painted finish.

**3.2.4.3 Magna T-Cell Ceiling System:** Steel framing members are cold-formed from galvanized steel conforming to ASTM A653, CS, Type B. Aluminum framing members are cold-formed from aluminum conforming to ASTM B209 Type 3003-H14. See [Table 2](#).

The steel web covers are cold-formed from galvanized steel conforming to ASTM A653, CS, Type B. The aluminum covers are cold-formed from aluminum conforming to ASTM B209, Type 3003-H14.

**3.2.5 Hanger and Bracing Wires:** Wires for ROCKFON® CHICAGO METALLIC™ suspended ceiling framing members and fixtures, must comply with ASTM C636 as referenced in 2021, 2018, 2015, 2012 and 2009 IBC Section 808 [2006 IBC Section 803.9] and Section 13.5.6 of ASCE 7 as referenced in IBC Sections 1613 and 2506.2.1.

**3.2.6 Accessories:** For systems described in Sections 3.2.1 through 3.2.3, each ROCKFON® CHICAGO METALLIC™ suspended ceiling system is provided with the necessary wall angles, wall channel molding, hold-down inserts, and edge caps to meet the requirements of the installation.

### 3.3 Seismic Perimeter Clip:

**3.3.1** The 1496 Seismic Perimeter Clip is illustrated in [Figure 1A](#). The clip is manufactured from minimum 0.0263-inch-thick (0.67 mm), SAE 1075 electro-galvanized steel complying with ASTM A879.

**3.3.2** The 479 clip is illustrated in [Figure 1B](#). The clip is manufactured from minimum 0.042-inch-thick (1.07 mm) steel complying with ASTM A653 CS Type B with a G30 coating.

### 3.4 ROCKFON® CHICAGO METALLIC™ Acoustical Tile Suspended Ceiling Framing Systems With 4.0 psf Seismic Weight (for Systems Described in Section 4.5):

**3.4.1 ROCKFON® CHICAGO METALLIC™ Acoustical Tile Ceiling Framing Systems for 1200, 4000, 4200 and 4500 systems:** The ROCKFON® CHICAGO METALLIC™ acoustical tile ceiling framing systems are exposed ceiling framing systems consisting of main runner and cross tee framing members used with lay-in acoustical tiles. Framing members for the acoustical tile ceiling framing systems addressed in Section 3.4.1 are noted in [Table 1](#) and are described in the following paragraphs of Section 3.4.1.

The 1200 and 4000 systems utilize cross tees with stake-on style end tabs that connect the cross tees together through slots in the main runners. The 1200 system consists of 200.xx2, 270.xx2, and/or 280.xx2 main runners and a combination of 1210 and 1202 cross tees. The 4000 system consists of 4040c main runners and a combination of 4014C and 4022C cross tees. The minimum wall angle for 1200 and 4000 systems is a wall angle with a catalog number of 1420, which has a base metal thickness of 0.020 inch (0.50 mm), a vertical leg of  $1^{5}/_{16}$  inch and a horizontal leg of  $1^{5}/_{16}$  inch (23.8 by 23.8 mm).

The 4200 and 4500 systems utilize cross tees with stake-on style end tabs that connect the cross tees together through slots in the main runners. The 4200 system has a hat shaped bottom cap (i.e., main runner cap and cross tee cap) that wraps the bottom flat flange and protrudes approx.  $1/4$  inch below the bottom flat flange. The 4500 system has a channel-shaped bottom flange with a longitudinal regress measuring  $1/4$  inch (6.4 mm). The 4200 system consists of 4200 main runners, 4204 and 4202 cross tees. The 4500 system consists of 4530 main runners and a combination of 4514 and 4512 cross tees. The minimum wall angle for 4200 and 4500 systems is a wall angle with a catalog number of 1467, which has a base metal thickness of 0.020 inch (0.50 mm), a vertical leg of  $1^{3}/_{16}$  inch and a horizontal leg of  $1^{5}/_{16}$  inch (30.2 by 23.8 mm).

**3.4.2 Materials:** Main runners and cross tees, including the cross-sectional dimensions, lengths and allowable transverse loads, are described in [Table 1](#) of this report. All main runners are classified in [Table 1](#) as heavy-duty in accordance with ASTM C635.

For the 1200 system, the main runners and cross tees are roll-formed from hot-dip galvanized steel



conforming to ASTM A653, CS, Type B.

For the 4000 system, the main runners and cross tees are roll-formed from hot-dip galvanized steel conforming to ASTM A653, CS, Type B.

For the 4200 system, the main runners and cross tees are roll-formed from hot-dip galvanized steel conforming to ASTM A653, CS, Type B.

For the 4500 system, the main runners and cross tees are roll-formed from electro-galvanized steel conforming to ASTM A1008, CS, Type B.

Wall angles of 1420 and 1467 are roll-formed from electro-galvanized steel conforming to ASTM A1008, CS, Type B or equivalent.

Aluminum caps on steel framing members (main runners and cross tees) have a polyester paint finish.

Cross tee stake-on end tabs are manufactured using ASTM A1011 high strength low alloy (HSLA) steel with a G30 hot-dipped galvanized coating, or a proprietary coating or AISI 201 or 301 stainless steel.

**3.4.3 Hanger and Bracing Wires:** Wires for ROCKFON® CHICAGO METALLIC™ suspended ceiling framing members, and fixtures, must comply with ASTM C636 as referenced in 2021, 2018, 2015, 2012 and 2009 IBC Section 808 [2006 IBC Section 803.9] and Section 13.5.6 of ASCE 7 as referenced in IBC Section 2506.2.1.

**3.4.4 Accessories:** Each ROCKFON® CHICAGO METALLIC™ suspended ceiling system is provided with the necessary accessories, such as wall angles and molding, in order to meet the installation requirements.

## 4.0 DESIGN AND INSTALLATION

### 4.1 ROCKFON® CHICAGO METALLIC™ Acoustical Tile Suspended Ceiling Framing Systems:

**4.1.1 General:** The ROCKFON® CHICAGO METALLIC™ suspended ceiling framing systems installed with acoustical tiles must be designed and installed in accordance with 2021, 2018, 2015, 2012 and 2009 IBC Sections 808, 1613 and 2506.2.1 (2006 IBC Sections 803.9, 1613 and 2506.2.1) including ASCE 7 referenced in IBC Section 1613, the manufacturer's installation instructions and this evaluation report. The minimum tension and compression capacity of the ceiling framing member connections is 180 pounds (800.7 N).

**4.1.2 Main Runners:** The design loads for main runners must be less than, or equal to, the capacities noted in [Table 1](#) of this report.

**4.1.3 Cross Runners (Cross Tees):** The maximum design loads for the cross runners must be less than or equal to the capacities shown in [Table 1](#).

**4.1.4 Partitions:** Partitions must be laterally supported as required by Section 13.5.8 of ASCE 7-16 for the 2021 and 2018 IBC (ASCE 7-10 for the 2015 and 2012 IBC and ASCE 7-05 for the 2009 and 2006 IBC), as referenced by IBC Section 1613.

**4.1.5 ROCKFON® CHICAGO METALLIC™ Suspended Ceiling Framing Members:** ROCKFON® CHICAGO METALLIC™ suspended ceiling framing members for use with the 1496 perimeter clip as described in Section 4.2.1 are Nos. 200, 270, 280, 640C, 4040B, 4040C, 4530, 4550, 4560, 4630, and 4660 main runners and Nos. 668C, 674C, 1210, 1214, 1236, 1254, 1264, 1274, 1278, 1280, 1284, 4014C, 4017C, 4018C, 4512, 4514, 4516, 4518, 4524, 4528, 4562, 4564, 4568, 4612, 4614, 4616, 4618, 4624 and 4628 cross runners manufactured by ROCKFON®. The framing members are described in [Table 1](#).

For use under the IBC for Seismic Design Categories A, B and C as described in Section 4.2.2, ceiling framing members may be any ROCKFON® CHICAGO METALLIC™ suspended ceiling framing recognized in [Table 1](#) and complying with the requirements of CISCA 0-2 (for the 2009 and 2006 IBC) and ASTM E580-14 (for the 2021 and 2018 IBC) or ASTM E580-09a Section 4 (for the 2015 and 2012 IBC).

**4.1.6 Seismic Design:** Seismic design and installation details of the ROCKFON® CHICAGO METALLIC™ suspended ceiling framing systems must be in accordance with Section 13.5.6 of ASCE 7-16 for the 2021 and 2018 IBC (ASCE 7-10 for the 2015 and 2012 IBC and ASCE 7-05 for the 2009 and 2006 IBC), as referenced in IBC Section 1613, except as noted in Section 4.2 of this report. Main runners described in [Table 1](#) classified as light-duty, intermediate-duty, or not classified are limited to use in Seismic Design Categories A, B and C.

### 4.2 ROCKFON® CHICAGO METALLIC™ Acoustical Tile Suspended Ceiling Framing Systems With 1496 or 479 Seismic Perimeter Clips based on AC156 shake table testing:

**4.2.1 Alternate Seismic Design Category D, E or F Installation:** With this installation, the main and cross

runners for ROCKFON® CHICAGO METALLIC™ suspended ceiling framing systems installed with acoustical tiles must be main and cross runners described in Section 4.1.5. Maximum total ceiling weight permitted is 2.5 lb/ft<sup>2</sup> (12.2 kg/m<sup>2</sup>). The 1496 clips are used to secure the main runners and cross runners to the wall closure (angle) on two adjacent walls (fixed ends) and to allow free movement of the runners on the two opposing walls (floating ends). See [Figure 2](#). A nominally 15/16-inch-wide (23.8 mm) wall (angle) is used in lieu of the 2-inch-wide (50.8 mm) perimeter wall angle required in Section 5 of ASTM E580 and Section 13.5.6.2.2 of ASCE 7-16 (for the 2021 and 2018 IBC), ASCE 7-10 (for the 2015 and 2012 IBC) and Section 13.5.6.2.2 of ASCE 7-5 (for the 2009 and 2006 IBC) for Seismic Design Categories D, E and F. Except for the use of the 1496 clips, the nominally 15/16-inch-wide (23.8 mm) wall angle, and the elimination of spacer bars (stabilizer bars), installation of the ceiling system must be as prescribed by the code.

The 1496 clip is attached to the wall closure by sliding the backplate of the clip over the vertical leg of the wall closure and over the bulb of the runner. On the two adjacent walls where the runners are fixed (fixed ends), the clips are attached to the runner by a minimum of one #7 by 7/16 inch-long (11.1 mm) sheet metal screw through one of the three pilot holes in the clip. On the walls where the runners are not fixed (floating ends), the clips must not be mechanically connected to the runner by any fastener and the clips allow the terminal runner end to move 3/4 inch (19.1 mm) towards and away from the wall. For both fixed ends and floating ends, the clips are not required to be mechanically connected to the wall angle by any fastener. Under the 2018 IBC, as required by Section 13.5.6.2.2 of ASCE 7-16, the 1496 clips must be screwed to the wall closure with two (2) screws and the wall closure must be positively attached to the wall studs or other supporting structure. The 1496 clips installed in this manner are an acceptable means of preventing perimeter runners from spreading, in lieu of the spacer bars (stabilizer bars) required in CISCA 3-4 (for the 2009 and 2006 IBC) and Section 5 of ASTM E580 (for the 2021, 2018, 2015 and 2012 IBC). ASTM E580 Section 5 is referenced in Section 13.5.6.2.2 of ASCE 7-16 under the 2018 IBC and ASCE 7-10 under the 2015 and 2012 IBC, in which ASCE 7 is referenced in the 2018, 2015 and 2012 IBC Section 1613. CISCA 3-4 is referenced in ASCE 7-05, Section 13.5.6.2.2, which is referenced in 2009 and 2006 IBC Section 1613. The assembly described in this Section 4.2.1 is equivalent to that required by CISCA 3-4 and Section 5 of ASTM E580.

A single 1/8-inch-diameter (3.175 mm) steel pop rivet complying with Industrial Fastener Institute Standard IFI-114 may be used in lieu of 1496 perimeter clips to secure the main runners and cross runners to the wall angle on two adjacent walls (fixed ends). The center of the rivet must be 0.25 inch (6.35 mm) from the edge of the wall angle. See [Figure 3](#).

**4.2.2 Alternate Seismic Design Category A, B or C Installation:** With this installation, the main and cross runners for ROCKFON® CHICAGO METALLIC™ suspended ceiling framing systems installed with acoustical tiles may be any suspended ceiling framing member recognized in Section 4.1.5. The 1496 clip may be used in lieu of spacer bars (stabilizer bars) in suspended ceiling installations regulated by CISCA 0-2 and ASTM E580 Section 4. The 1496 clip is attached to the wall closure (angle) by sliding the backplate of the clip over the hem on the vertical leg of the wall angle and over the bulb of the runner. The clips are placed at the intersections of all runners and the wall angles, and the clips are not required to be mechanically connected to the runner or the wall angle by any fastener. The clips must be positioned to allow a minimum 3/8-inch (9.5 mm) movement in both directions. The maximum ceiling weight permitted is 2.5 lb/ft<sup>2</sup> (12.2 kg/m<sup>2</sup>). See [Figure 4](#). Except for the use of the 1496 clips and the elimination of spacer bars, installation of the ceiling system must be as prescribed by the code. The 1496 clips installed in this manner are used in lieu of stabilizer bars required by Section 4 of ASTM E580 and CISCA 0-2. This assembly described in this Section 4.2.2 is equivalent to that required by CISCA 0-2 (for the 2009 and 2006 IBC) and Section 4 of ASTM E580 (for the 2021, 2018, 2015 and 2012 IBC). CISCA 0-2 is referenced in ASCE 7-05, Section 13.5.6.2.1, which is referenced in 2009 and 2006 IBC Section 1613. Section 4 of ASTM E580 is referenced in Section 13.5.6.2.1 of ASCE 7-16 under the 2018 IBC and ASCE 7-10 under the 2015 and 2012 IBC, in which ASCE 7 is referenced in 2018, 2015 and 2012 IBC Section 1613.

**4.2.3 Alternate Seismic Design Category D, E or F Installation using 6 feet and 8 feet long cross tees 1200, 4000c, 4500 and 4600 series:** With this installation, the main and cross runners for ROCKFON® CHICAGO METALLIC™ suspended ceiling framing systems installed with acoustical tiles must be main and cross runners described in Section 4.1.5. Maximum total ceiling weight permitted is 2.5 lb/ft<sup>2</sup> (12.2 kg/m<sup>2</sup>). The 1496 clips are used to secure the main runners and cross runners to the wall closure (angle) on two adjacent walls (fixed ends) and to allow free movement of the runners on the two opposing walls (floating ends). See [Figure 2](#). A nominally 15/16-inch-wide (23.8 mm) wall (angle) is used in lieu of the 2-inch-wide (50.8 mm) perimeter wall angle required in Section 5 of ASTM E580 and Section 13.5.6.2.2 of ASCE 7-16 (for the 2021 and 2018 IBC), ASCE 7-10 (for the 2015 and 2012 IBC) and Section 13.5.6.2.2 of ASCE 7-5

(for the 2009 and 2006 IBC) for Seismic Design Categories D, E and F. The 6-foot- and 8-foot-long cross tees that must have mid-span support using 12-gauge hanger wire are 1236 (6ft), 1278 (8ft), 4017c (6ft), 4018c (8ft), 4516 (6ft), 4528 (8ft), 4616 (6ft), 4628 (8ft). Except for the use of the 1496 clips, the nominally  $1\frac{5}{16}$ -inch-wide (23.8 mm) wall angle, the mid-span hanger wire support and the elimination of spacer bars (stabilizer bars), installation of the ceiling system must be as prescribed by the code.

The 1496 clip is attached to the wall closure by sliding the backplate of the clip over the vertical leg of the wall closure and over the bulb of the runner. On the two adjacent walls where the runners are fixed (fixed ends), the clips are attached to the runner by a minimum of one #7 by  $\frac{7}{16}$  inch-long (11.1 mm) sheet metal screw through one of the three pilot holes in the clip. On the walls where the runners are not fixed (floating ends), the clips must not be mechanically connected to the runner by any fastener and the clips allow the terminal runner end to move  $\frac{3}{4}$  inch (19.1 mm) towards and away from the wall. For both fixed ends and floating ends, the clips are required to be mechanically connected to the wall angle with two #8 sheet metal screws (See [Figure 5](#)). Under the 2021 and 2018 IBC, as required by Section 13.5.6.2.2 of ASCE 7-16, the wall closure must be positively attached to the wall studs or other supporting structure. The 1496 clips installed in this manner are an acceptable means of preventing perimeter runners from spreading, in lieu of the spacer bars (stabilizer bars) required in CISCA 3-4 (for the 2009 and 2006 IBC) and Section 5 of ASTM E580 (for the 2018, 2015 and 2012 IBC). ASTM E580 Section 5 is referenced in Section 13.5.6.2.2 of ASCE 7-16 under the 2018 IBC and ASCE 7-10 under the 2015 and 2012 IBC, in which ASCE 7 is referenced in the 2021, 2018, 2015 and 2012 IBC Section 1613. CISCA 3-4 is referenced in ASCE 7-05, Section 13.5.6.2.2, which is referenced in 2009 and 2006 IBC Section 1613. The assembly described in this Section 4.2.1 is equivalent to that required by CISCA 3-4 and Section 5 of ASTM E580.

A single  $\frac{1}{8}$ -inch-diameter (3.175 mm) pop rivet with steel mandrel complying with Industrial Fastener Institute Standard IFI-114 may be used in lieu of 1496 perimeter clips to secure the main runners and cross runners to the wall angle on two adjacent walls (fixed ends) (See [Figure 6](#)). The center of the rivet must be 0.25 inch (6.35 mm) from the edge of the wall angle. See [Figure 3](#).

**4.2.4 Alternate Seismic Design Category A, B or C Installation, Maximum  $S_{DS}$  of 0.5 g with Criterion 3 Level Performance in accordance with ASTM E3118:** With this installation, the 200, 4000, 4200, 4500 and 4600 series main runners and 1200, 4000, 4200, 4500 and 4600 series cross runners listed in [Table 1](#) are installed with acoustical tiles. The maximum ceiling weight permitted is 2.5 lb/ft<sup>2</sup> (12.2 kg/m<sup>2</sup>). For the 200, 1200, 4000 and 4200 main and cross runner series, a pop rivet, 479 clip or 1496 clip is used to secure the main runners and cross runners to the  $\frac{7}{8}$ -inch-wide or  $1\frac{5}{16}$ -inch-wide (22.2 or 23.8 mm) wall closure angles (1420 or 1430) on two adjacent walls (fixed sides). For the 4500 and 4600 main and cross runner series, the 479 and 1496 clips are used to secure the main and cross runners to the  $1\frac{5}{16}$ -inch-wide (23.8 mm) wall closure angles (1467) on the fixed sides. For all listed systems, a 1496 clip is used to allow free movement of the runners on the two opposing walls (floating sides). See [Figure 7](#).

The 1496 clip is attached to the wall closure angles by sliding the backplate of the clip over the hem on the vertical leg of the wall angle and over the bulb of the runner. The clips are secured to the wall closure angle by two No. 8 by  $\frac{9}{16}$ -inch-long (14.3 mm) sheet metal screws. On the floating sides, the 1496 clips must be positioned to allow a minimum  $\frac{3}{8}$ -inch (9.5 mm) movement. On the fixed sides, the 1496 clips are attached to the runner by using one No. 7 by  $\frac{7}{16}$ -inch-long (11.1 mm) sheet metal screw through one of the three pilot holes in the clip. See [Figure 7](#).

The 479 clips are secured to the wall closure angle by two No. 8 by  $\frac{9}{16}$ -inch-long (14.3 mm) sheet metal screws and attached to the runner by using one No. 7 by  $\frac{7}{16}$ -inch-long (11.1 mm) sheet metal screw through one of the predrilled holes in the clip. See [Figure 7](#).

Except for the installation described in this section (Section 4.2.4), installation of the ceiling system must be as prescribed by the code. The pop rivet, 1496 and 479 clips installed in this manner are used in lieu of stabilizer bars required by Section 4 of ASTM E580 and CISCA 0-2. This assembly described in this Section 4.2.4 is equivalent to that required by CISCA 0-2 (for the 2009 and 2006 IBC) and Section 4 of ASTM E580 (for the 2021, 2018, 2015 and 2012 IBC). CISCA 0-2 is referenced in ASCE 7-05, Section 13.5.6.2.1, which is referenced in 2009 and 2006 IBC Section 1613. Section 4 of ASTM E580 is referenced in Section 13.5.6.2.1 of ASCE 7-16 under the 2018 IBC and ASCE 7-10 under the 2015 and 2012 IBC, in which ASCE 7 is referenced in 2018, 2015 and 2012 IBC Section 1613.

**4.3 ROCKFON® CHICAGO METALLIC™ Suspended Ceiling Framing Systems for Gypsum Wallboard:** The installation must be in accordance with applicable provisions of IBC Chapter 25 and Section 4.1, except the ceilings must be designed for seismic loads required under Chapter 13 of ASCE 7. Ceilings constructed of

gypsum board, screw or nail attached to suspended members that support the ceiling on one level extending from wall to wall are exempt from the lateral load design requirements of CISC Zones 3-4 and ASTM E580, as referenced in Section 13.5.6 of ASCE 7, in accordance with IBC Section 1613. The total ceiling weight must not exceed 4 psf (19.5 kg/m<sup>2</sup>).

#### **4.4 ROCKFON® CHICAGO METALLIC™ Metaline, Planostile and Magna T-Cell Suspended Ceiling Systems:**

**4.4.1 General:** The ROCKFON® CHICAGO METALLIC™ suspended ceiling systems must be designed and installed in accordance with 2021, 2018, 2015, 2012 and 2009 IBC Sections 808, 1613 and 2506.2.1 (2006 IBC Sections 803.9, 1613 and 2506.2.1) including ASCE 7 referenced in IBC Section 1613, the manufacturer's installation instructions and this evaluation report. The minimum tension and compression capacity of the ceiling framing member connections is 180 pounds (800.7 N).

**4.4.1.1 Main Runners:** The design loads for main runners must be less than or equal to the allowable loads in [Table 2](#) of this report. Main runners of all systems must be installed in direct-hung installations.

**4.4.1.2 Cross Runners:** The maximum applied loads for the cross runners must be less than or equal to the allowable loads in [Table 2](#) of this report.

#### **4.4.2 Ceiling Panels:**

**4.4.2.1 Metaline:** Metaline metal ceiling panels are placed through the ceiling framing and then pushed downward, with the panels resting on the flanges of both the main and cross runners, and the panel leg snapping and locking under the beads of both the main and cross runners. Access panels are mounted within the grid module of the ceiling framing and secured to the flange of the framing with No. 10 by 0.5-inch-long (12.7 mm) button-head screws spaced 6 inches (152 mm) on center.

**4.4.2.2 Planostile:** Planostile "Snap-In" metal ceiling panels are aligned with the face of the grid, pushed upward, and snapped onto the MA010.500CH main runners. "Lay-In" metal panels are placed through the grid module and rest on the bottom flange of the framing members.

**4.4.2.3 Magna T-Cell:** Magna T-cell system is a grid-based ceiling system consisting of cross tees with stake-on style end tabs, which connect two cross tees together through a slot of a main runner. Web covers are a cosmetic covering consisting of an inverted U shape that is placed over the bulb and web of both the main runners and cross runners prior to hanging the components in a ceiling. The hanger wires pass through both the web cover and the body of the T grid.

**4.4.3 Partitions:** Partitions must be laterally supported as required by Section 13.5.8 of ASCE 7-16 for the 2021 and 2018 IBC (ASCE 7-10 for the 2015 and 2012 IBC and ASCE 7-05 for the 2009 and 2006 IBC), as referenced by IBC Section 1613.

**4.4.4 Seismic Design:** Seismic design and installation details of the ROCKFON® CHICAGO METALLIC™ suspended ceiling systems must be in accordance with Section 13.5.6 of ASCE 7-16 for the 2021 and 2018 IBC (ASCE 7-10 for the 2015 and 2012 IBC and ASCE 7-05 for the 2009 and 2006 IBC), as referenced in IBC Section 1613. Main runners described in [Table 2](#) classified as light duty, intermediate-duty or not classified are limited to use in Seismic Design Categories A, B and C.

#### **4.5 ROCKFON® CHICAGO METALLIC™ Acoustical Tile Suspended Ceiling Framing Systems With 1496 Seismic Perimeter Clips and 4.0 psf Total Ceiling Weight based on AC156 shake table testing:**

**4.5.1 Alternate Seismic Design Category D, E or F Installation:** With this installation, the framing members for ROCKFON® CHICAGO METALLIC™ suspended ceiling framing systems installed with acoustical tiles must be the framing members described in Section 3.4. Maximum total ceiling weight is limited to 4.0 lb/ft<sup>2</sup> (19.5 kg/m<sup>2</sup>). The 1496 clips are used to secure the main runners and cross runners to the wall closure (angle) on two adjacent walls (fixed ends) and to allow free movement of the runners on the two opposing walls (floating ends). See [Figure 5](#). A perimeter support ledge of <sup>15</sup>/<sub>16</sub>-inch wide (23.8 mm) of 1420 or 1467 wall angles is used in lieu of the 2-inch-wide (50.8 mm) perimeter support ledge required in Section 5 of ASTM E580 and Section 13.5.6.2.2 of ASCE 7-16 (for the 2021 and 2018 IBC), ASCE 7-10 (for the 2015 and 2012 IBC) and Section 13.5.6.2.2 of ASCE 7-05 (for the 2009 and 2006 IBC) for Seismic Design Categories D, E and F. Except for the use of the 1496 clips, the nominally <sup>15</sup>/<sub>16</sub>-inch-wide (23.8 mm) wall angle, and the elimination of spacer bars (stabilizer bars), installation of the ceiling system must be as prescribed by the code.

The 1496 clip is attached to the wall closure by sliding the backplate of the clip over the vertical leg of the wall closure and over the bulb of the runner. On the two adjacent walls where the runners are fixed



(fixed ends), each clip is attached to the wall closure by a minimum of two #8 by  $\frac{9}{16}$ -inch-long (14.3 mm) sheet metal screws through the bottom two pilot holes in the clip, and are attached to the runner by a minimum of one #7 by  $\frac{7}{16}$ -inch-long (11.1 mm) sheet metal screw through one of the three pilot holes in the clip. On the walls where the runners are not fixed (floating ends), each clip is attached to the wall closure by a minimum of two #8 by  $\frac{9}{16}$ -inch-long (14.3 mm) sheet metal screws through the bottom two pilot holes in the clip, and the clip must not be mechanically connected to the runner by any fastener, and the installed clips allow the terminal runner end to move  $\frac{3}{4}$  inch (19.1 mm) towards and away from the wall. Under the 2018 IBC, as required by Section 13.5.6.2.2 of ASCE 7-16, the wall closure must be positively attached to the wall studs or other supporting structure. The 1496 clips installed in this manner are an acceptable means of preventing perimeter runners from spreading, in lieu of the spacer bars (stabilizer bars) required in CISCA 3-4 (for the 2009 and 2006 IBC) and Section 5 of ASTM E580 (for the 2021, 2018, 2015 and 2012 IBC). ASTM E580 Section 5 is referenced in Section 13.5.6.2.2 of ASCE 7-16 under the 2021 and 2018 IBC and ASCE 7-10 under the 2015 and 2012 IBC, in which ASCE 7 is referenced in the 2018, 2015 and 2012 IBC Section 1613. CISCA 3-4 is referenced in ASCE 7-05, Section 13.5.6.2.2, which is referenced in 2009 and 2006 IBC Section 1613. The assembly described in this Section 4.5.1 is equivalent to that required by CISCA 3-4 and Section 5 of ASTM E580.

A single  $\frac{1}{8}$ -inch-diameter (3.175 mm) aluminum pop rivet with steel mandrel (or break mandrel blind rivet) complying with Industrial Fastener Institute Standard IFI-114 may be used in lieu of 1496 perimeter clips to secure the main runners and cross runners to the wall angle on two adjacent wall fixed ends. The center of the rivet must be 0.25 inch (6.35 mm) from the edge of the wall angle. See [Figure 6](#).

#### 4.5.2 Alternate Seismic Design Category A, B or C Installation:

For ceiling systems with a maximum ceiling weight up to 2.5 lb/ft<sup>2</sup> (12.2 kg/m<sup>2</sup>): With this installation, the framing members for suspended ceiling framing systems installed with acoustical tiles may be any suspended ceiling framing member recognized in Section 3.4. The 1496 clip may be used in lieu of spacer bars (stabilizer bars) in suspended ceiling installations regulated by CISCA 0-2 and ASTM E580 Section 4. The 1496 clip is attached to the wall closure (angle) by sliding the backplate of the clip over the hem on the vertical leg of the wall angle and over the bulb of the runner. The clips are placed at the intersections of all runners and the wall angle, and the clips are not required to be mechanically connected to the runner or the wall angle by any fastener. The clips must be positioned to allow a minimum  $\frac{3}{8}$ -inch (9.5 mm) movement in both directions. See [Figure 4](#). Except for the use of the 1496 clips and the elimination of spacer bars, installation of the ceiling system must be as prescribed by the code. The 1496 clips installed in this manner are used in lieu of stabilizer bars required by Section 4 of ASTM E580 and CISCA 0-2. This assembly described in this Section 4.5.2 is equivalent to that required by CISCA 0-2 (for the 2009 and 2006 IBC) and Section 4 of ASTM E580 (for the 2021, 2018, 2015 and 2012 IBC). CISCA 0-2 is referenced in ASCE 7-05, Section 13.5.6.2.1, which is referenced in 2009 and 2006 IBC Section 1613. Section 4 of ASTM E580 is referenced in Section 13.5.6.2.1 of ASCE 7-16 under the 2021 and 2018 IBC and ASCE 7-10 under the 2015 and 2012 IBC, in which ASCE 7 is referenced in 2018, 2015 and 2012 IBC Section 1613.

For ceiling systems with a maximum ceiling weight exceeding 2.5 lb/ft<sup>2</sup> (12.2 kg/m<sup>2</sup>) and up to 4.0 lb/ft<sup>2</sup> (19.5 kg/m<sup>2</sup>): The requirements described in Section 4.5.1 are applicable.

#### 4.6 Special Inspections:

Where special inspections are required by the building official, the ROCKFON® CHICAGO METALLIC™ suspended ceiling systems (including suspended ceiling framing systems) in Seismic Design Categories C, D, E, and F shall be subject to periodic special inspections during the installation of the suspended ceiling systems and their anchorage in accordance with the following requirements:

- For installations in accordance with Sections 4.2 and 4.5.4 of this report, special inspection must be conducted as required by the building official during enforcement of the 2021, 2018 and 2015 IBC Sections 1704.5, 1705.1.1 and 1705.13.2 (2012 IBC Sections 1705.1.1, Item 3 of Section 1705.12 and Section 1705.12.3; 2009 IBC Sections 1704.15, 1708.4 and Item 3 of Section 1708.1; 2006 IBC Sections 1704.13, 1708.5 and Item 3 of Section 1708.2), as applicable.
- For installations in accordance with Sections 4.1, 4.3 and 4.4 of this report, special inspection must be conducted as indicated in Section 13.5.6.2.2 (h) of ASCE 7-05, and 2009 IBC Section 1705.3.4, Item 3, under the 2009 IBC; Section 13.5.6.2.2 (h) of ASCE 7-05, and 2006 IBC Section 1705.3, Item 4.3, under the 2006 IBC, as applicable.

- The special inspector must verify that the ceiling framing systems and ceiling systems are as described in this report, and comply with this report and the approved construction documents.

Where special inspections are required by the building official, a statement of special inspections must be provided as required by the Section 1704.3 for the 2021, 2018, 2015 and 2012 IBC (Sections 1705.2 and 1705.3 for the 2009 IBC; and Sections 1705.2 and 1705.3 for the 2006 IBC, as applicable).

## 5.0 CONDITIONS OF USE:

The ROCKFON<sup>®</sup> CHICAGO METALLIC<sup>™</sup> suspended ceiling framing systems and suspended ceiling systems described in this report comply with, or are suitable alternatives to what is specified in, those codes listed in Section 1.0 of this report, subject to the following conditions:

- 5.1** ROCKFON<sup>®</sup> CHICAGO METALLIC<sup>™</sup> suspended ceiling framing systems and suspended ceiling systems must be fabricated and installed in accordance with this report and the manufacturer's published installation instructions. In the event of a conflict between the manufacturer's installation instructions and this report, this report governs.
- 5.2** For systems described in Sections 4.1 through 4.3, and Section 4.5, design loads and spans of main runners, cross tees, furring runners and furring tees must comply with [Table 1](#) of this report.
- 5.3** For systems described in Section 4.4, design loads of main and cross runners must not exceed the allowable loads stated in [Table 2](#) of this report.
- 5.4** ROCKFON<sup>®</sup> CHICAGO METALLIC<sup>™</sup> suspended ceiling framing systems and ceiling systems noted in Sections 4.1 through 4.5 must be designed in accordance with Section 13.5.6 of ASCE 7 as referenced by IBC Section 1613. The documents must be prepared by a registered design professional where required by statutes of the jurisdiction in which the project is to be constructed.
- 5.5** Where required by the building official, special inspections must be provided in accordance with Section 4.6 of this report.
- 5.6** The ceiling framing systems and ceiling systems noted in Sections 4.1 through 4.5 must not be used to provide lateral support for walls or partitions, except as provided for in ASCE 7, Section 13.5.8.1, as referenced in IBC Section 1613.
- 5.7** The ceiling framing systems and ceiling systems noted in Sections 4.1 through 4.5 must be braced to resist seismic forces as determined from Section 1613 of the IBC.
- 5.8** The supporting construction for the ceiling framing systems and for ceiling systems noted in Sections 4.1 through 4.5 has not been evaluated and is outside the scope of this report. The code official must approve the floor or roof construction supporting the ROCKFON<sup>®</sup> CHICAGO METALLIC<sup>™</sup> suspended ceiling framing systems and ceiling systems.
- 5.9** The ceiling framing systems and ceiling systems noted in Sections 4.1 through 4.5 are limited to interior applications and to ceilings not considered accessible in accordance with Item 28 of the 2021, 2018, 2015 and 2012 IBC Table 1607.1 (Item 31 of the 2009 IBC Table 1607.1, or Item 32 of the 2006 IBC Table 1607.1).
- 5.10** Lay-in acoustical ceiling panels must be justified to the satisfaction of the code official as complying with the interior finish requirements of Chapter 8 of the IBC.
- 5.11** Use of the ceiling framing systems and ceiling systems in fire-resistance-rated assemblies is outside the scope of this report.
- 5.12** Lighting fixtures and other service devices within ceilings must be supported in accordance with industry standard construction requirements specified in Section 13.5.6 of ASCE 7, as referenced by IBC Section 1613.

## 6.0 EVIDENCE SUBMITTED

- 6.1** Data in accordance with the [ICC-ES Acceptance Criteria for Suspended Ceiling Framing Systems \(AC368\)](#), dated November 2019 (editorially revised March 2021).
- 6.2** Reports of comparative seismic qualification tests for ROCKFON<sup>®</sup> CHICAGO METALLIC<sup>™</sup> suspended ceiling framing systems described in Sections 4.2 and 4.5 in accordance with the [ICC-ES Acceptance Criteria for Seismic Certification by Shake-table Testing of Nonstructural Components AC156 \(24\) 2<sup>nd</sup> Edition](#), Published April 2025, including data for compliance with AC156 Section 4.5 "Component Product Line Extrapolation and Interpolation".

## 7.0 IDENTIFICATION

- 7.1 Product labeling shall include the name of the report holder or listee, and the ICC-ES mark of conformity. The listing or evaluation report number (ICC-ES ESR-2631) may be used in lieu of the mark of conformity. Cartons of all products are identified with the report holder's name (ROCKFON<sup>®</sup>); the product name and product number; a manufacturing quality code for traceability and the evaluation report number (ESR-2631).
- 7.2 The report holder's contact information is the following:

**ROXUL USA INC. d/b/a ROCKFON**  
**4849 SOUTH AUSTIN AVENUE**  
**CHICAGO, ILLINOIS 60638**  
**(800) 323-7164**  
[www.rockfon.com](http://www.rockfon.com)

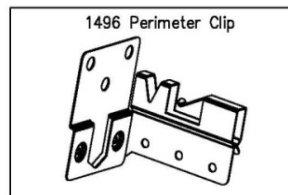

FIGURE 1A

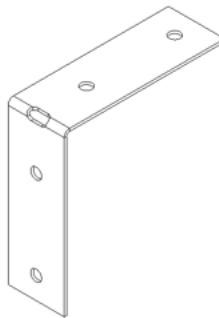

FIGURE 1B

TABLE 1—ALLOWABLE LOADS FOR MEMBERS DESCRIBED IN SECTIONS 3.1 AND 3.4<sup>1, 2, 8, 9</sup>

Member	DIMENSIONS OF MEMBERS							SIMPLE SPAN				ALLOWABLE SPACING BETWEEN LATERAL BRACING (in)
	Catalog Number	ASTM C635 Duty Classification	Thickness (in)	Exposed Flange Width (in)	Height of Section (in)	Bulb Section Width (in)	Length of Section (ft)	Uniform Load (lb/ft)		Concentrated Load at Midspan (lb)		
								4-ft Span	5-ft Span	4-ft Span	5-ft Span	
Main Runners	<b>200 Series Main Runners</b>											
	200	Heavy	0.020	15/16	1 17/32	1/4	12	16.0	-	-	-	24
	200.xx	Heavy	0.0185	15/16	1 41/64	1/4	12	16.2	-	-	-	48
	211	Intermediate	0.012	15/16	1 41/64	1/4	12	12.1	-	-	-	24
	211V	Intermediate	0.015	15/16	1 17/32	1/4	12	12.6	-	-	-	24
	216	Intermediate	0.012	15/16	1 41/64	1/4	10	12.1	-	-	-	24
	219	Intermediate	0.012	15/16	1 41/64	1/4	10	12.1	-	-	-	24
	219V	Intermediate	0.015	15/16	1 17/32	1/4	10	12.6	-	-	-	24
	220V	Intermediate	0.015	15/16	1 1/2	1/4	12	12.6	-	-	-	24
	240V	Intermediate	0.015	15/16	1 1/2	1/4	12	12.6	-	-	-	24
	250	Intermediate	0.012	15/16	1 41/64	1/4	12	12.1	-	-	-	24
	250V	Intermediate	0.015	15/16	1 17/32	1/4	12	12.6	-	-	-	24
	260	Intermediate	0.0125	15/16	1 41/64	1/4	12	12.1	-	-	-	24
	260V	Intermediate	0.015	15/16	1 17/32	1/4	12	12.6	-	-	-	24
	270	Heavy	0.020	15/16	1 17/32	1/4	12	16.0	-	-	-	24
	270.xx	Heavy	0.0185	15/16	1 41/64	1/4	12	16.2	-	-	-	48
	280	Heavy	0.020	15/16	1 17/32	1/4	12	16.0	-	-	-	24
	280.xx	Heavy	0.0185	15/16	1 41/64	1/4	12	16.2	-	-	-	48
	299	Intermediate	0.012	15/16	1 41/64	1/4	10	12.1	-	-	-	24
	299V	Intermediate	0.015	15/16	1 17/32	1/4	10	12.6	-	-	-	24
	<b>600 Series Furring Runners</b>											
	640C	Heavy	0.020	1 3/8	1 1/2	1/4	12	18.2	-	-	-	24
	650C	Heavy	0.020	1 3/8	1 1/2	1/4	12	18.2	-	-	-	24
	669C	Intermediate	0.015	15/16	1 17/32	1/4	12	12.0	-	-	-	24
	<b>730 and 830 Series Main Runners</b>											
	730	Intermediate	0.015	15/16	1 1/2	1/4	12	13.7	-	-	-	24
	730	Light	0.015	15/16	1 1/2	1/4	12	10.5	-	-	-	48
	830	Light	0.024	15/16	1 1/2	1/4	12	8.0	-	-	-	24
	<b>1800 Series Main Runners</b>											
	1800	Heavy	0.020	15/16	1 1/2	1/4	12	16.0	8.9	41.7	25.0	24/30 <sup>3</sup>
	1800	Heavy	0.020	15/16	1 1/2	1/4	12	16.0	7.5	40.9	20.5	48/60 <sup>3</sup>
	1810	Heavy	0.024	15/16	1 1/2	1/4	12	18.6	8.0	37.0	23.5	24/30 <sup>3</sup>
	1810	Heavy	0.024	15/16	1 1/2	1/4	12	17.6	8.0	37.0	23.5	48/60 <sup>3</sup>
	1811	Intermediate	0.015	15/16	1 1/2	1/4	12	12.6	7.3	30.5	15.0	24/30 <sup>3</sup>
	1811	Light	0.015	15/16	1 1/2	1/4	12	9.0	7.4	30.5	15.0	48/60 <sup>3</sup>
	1830	Intermediate	0.015	15/16	1 1/2	1/4	12	12.6	6.8	30.5	12.0	24/30 <sup>3</sup>
	1830	Light	0.015	15/16	1 1/2	1/4	12	10.8	6.5	20.0	12.0	48/60 <sup>3</sup>
	1850	Intermediate	0.015	15/16	1 1/2	1/4	12	12.6	7.3	30.5	21.4	24/30 <sup>3</sup>
	1850	Light	0.015	15/16	1 1/2	1/4	12	9.0	7.4	30.5	21.4	48/60 <sup>3</sup>
	1860	Intermediate	0.015	15/16	1 1/2	1/4	12	12.6	6.8	30.5	12.0	24/30 <sup>3</sup>
	1860	Light	0.015	15/16	1 1/2	1/4	12	10.8	6.5	20.0	12.0	48/60 <sup>3</sup>
	1870	Heavy	0.020	15/16	1 1/2	1/4	12	16.0	8.0	41.7	20.0	24/30 <sup>3</sup>
	1870	Heavy	0.020	15/16	1 1/2	1/4	12	16.0	8.0	40.9	20.0	48/60 <sup>3</sup>
	1880	Heavy	0.020	15/16	1 1/2	1/4	12	16.0	-	-	-	24
	<b>3500 Series Main Runners</b>											
3500	Intermediate	0.015	9/16	1 5/8	1/4	12	12.1	5.8	-	-	24/30 <sup>3</sup>	
3501	NA <sup>6</sup>	0.015	9/16	1 5/8	1/4	10	-	5.8	-	-	30	
3502	NA <sup>6</sup>	0.015	9/16	1 5/8	1/4	10	-	5.8	-	-	30	
3530	Heavy	0.020	9/16	1 5/8	1/4	12	16.3	-	33.0	-	24	
3531	NA <sup>6</sup>	0.020	9/16	1 5/8	1/4	10	-	8.6	-	25.8	30	
3532	NA <sup>6</sup>	0.020	9/16	1 5/8	1/4	10	-	8.4	-	24.9	20	
3550	Intermediate	0.020	9/16	1 5/8	1/4	12	13.3	-	-	-	24	
<b>3600 Series Main Runners</b>												
3600	Intermediate	0.015	9/16	1 5/8	1/4	12	12.1	-	-	-	24/30 <sup>3</sup>	
3601	NA <sup>6</sup>	0.015	9/16	1 5/8	1/4	10	-	5.8	-	20.2	30	
3602	NA <sup>6</sup>	0.015	9/16	1 5/8	1/4	10	-	6.6	-	20.1	20	
<b>3700 Series Main Runners</b>												
3700	Light	0.020	9/16	1 1/2	3/16	12	9.5	5.5	22.5	13.0	24/30 <sup>3</sup>	
3700	Light	0.020	9/16	1 1/2	3/16	12	7.0	2.5	-	-	48/60 <sup>3</sup>	
3701	NA <sup>6</sup>	0.020	9/16	1 1/2	3/16	10	-	5.5	-	13.0	30	
3701	NA <sup>6</sup>	0.020	9/16	1 1/2	3/16	10	-	2.5	-	-	60	



**TABLE 1—ALLOWABLE LOADS FOR MEMBERS DESCRIBED IN SECTIONS 3.1 AND 3.4<sup>1, 2, 8, 9</sup> (Continued)**

Member	DIMENSIONS OF MEMBERS							SIMPLE SPAN				ALLOWABLE SPACING BETWEEN LATERAL BRACING (in)
	Catalog Number	ASTM C635 Duty Classification	Thickness (in)	Exposed Flange Width (in)	Height of Section (in)	Bulb Section Width (in)	Length of Section (ft)	Uniform Load (lb/ft)		Concentrated Load at Midspan (lb)		
								4-ft Span	5-ft Span	4-ft Span	5-ft Span	
<b>3800 Series Main Runners</b>												
	3800	Light	0.018	3/4	1 1/2	3/16	12	10.0	5.5	21.0	13.0	24/30 <sup>3</sup>
	3800	Light	0.018	3/4	1 1/2	3/16	12	7.0	4.5	18.5	10.5	48/60 <sup>3</sup>
	3801	NA <sup>6</sup>	0.018	3/4	1 1/2	3/16	10	-	5.5	-	13.0	30
	3801	NA <sup>6</sup>	0.018	3/4	1 1/2	3/16	10	-	4.5	-	10.5	60
<b>4000 Series Main Runners</b>												
	4000C	Intermediate	0.018	9/16	1 1/2	1/4	12	12.6	-	-	-	24
	4001C	Intermediate	0.018	9/16	1 1/2	1/4	10	12.6	-	-	-	24
	4040B	Heavy	0.020	9/16	1 1/2	1/4	12	16.0	-	-	-	24
	4040C	Heavy	0.020	9/16	1 1/4	1/4	12	16.5	8.7	-	-	24
	4050C	Intermediate	0.018	9/16	1 1/2	1/4	12	12.6	-	-	-	24
<b>4200 Series Main Runners</b>												
	4200	Heavy	0.020	9/16	1 29/32	1/4	12	16.5	8.7	-	-	24
<b>4500 Series Main Runners</b>												
Main Runners	4500	Intermediate	0.015	9/16	1 25/32	1/4	12	14.6	-	-	-	24
	4501	Intermediate	0.015	9/16	1 25/32	1/4	10	7.5	-	-	-	48
	4501	Intermediate	0.015	9/16	1 25/32	1/4	10	-	4.35	-	-	60
	4502	Intermediate	0.015	9/16	1 25/32	1/4	10	14.0	-	-	-	20
	4503	Intermediate	0.015	9/16	1 25/32	1/4	10	14.6	-	-	-	24
	4530	Heavy	0.019	9/16	1 25/32	1/4	12	17.6	-	-	-	24
	4532	Heavy	0.019	9/16	1 25/32	1/4	10	17.3	-	-	-	20
	4540	Intermediate	0.015	9/16	1 25/32	1/4	12	14.6	-	-	-	24
	4550	Heavy	0.019	9/16	1 25/32	1/4	12	17.6	-	-	-	24
	4560	Heavy	0.019	9/16	1 25/32	1/4	12	17.6	-	-	-	24
<b>4600 Series Main Runners</b>												
	4600	Intermediate	0.015	9/16	1 25/32	1/4	12	14.6	-	-	-	24
	4601	Intermediate	0.015	9/16	1 25/32	1/4	10	7.5	-	-	-	48
	4601	Intermediate	0.015	9/16	1 25/32	1/4	10	-	4.35	-	-	60
	4602	Intermediate	0.015	9/16	1 25/32	1/4	10	14.0	-	-	-	20
	4603	Intermediate	0.015	9/16	1 25/32	1/4	10	14.6	-	-	-	24
	4630	Heavy	0.019	9/16	1 25/32	1/4	12	17.6	-	-	-	24
	4632	Heavy	0.019	9/16	1 25/32	1/4	10	17.3	-	-	-	20
	4640	Intermediate	0.015	9/16	1 25/32	1/4	12	14.6	-	-	-	24
	4660	Heavy	0.019	9/16	1 25/32	1/4	12	17.6	-	-	-	24
<b>600 Series Furring Tees</b>												
Furring Tees	634C	NA <sup>6</sup>	0.020	1 3/8	7/8	None	4	8.2	-	-	-	48
	643C	NA <sup>6</sup>	0.020	1 3/8	1 1/2	1/4	4	18.6	-	-	-	48
	644C	NA <sup>6</sup>	0.014	1 3/8	1 1/2	1/4	4	14.3	-	-	-	48
	653C	NA <sup>6</sup>	0.020	1 3/8	1 1/2	1/4	4	18.6	-	-	-	48
	654C	NA <sup>6</sup>	0.014	1 3/8	1 1/2	1/4	4	14.3	-	-	-	48
	663C	NA <sup>6</sup>	0.020	1 3/8	1 1/2	1/4	4	18.6	-	-	-	48
	664C	NA <sup>6</sup>	0.014	1 3/8	1 1/2	1/4	4	14.3	-	-	-	48
	664C01A	NA <sup>6</sup>	0.014	1 3/8	1 1/2	1/4	4	14.3	-	-	-	48
	668C	NA <sup>6</sup>	0.012	1 3/8	1 1/2	1/4	4	12.3	-	-	-	48
	673C	NA <sup>6</sup>	0.020	1 3/8	1 1/2	1/4	4	18.6	-	-	-	48
674C	NA <sup>6</sup>	0.014	1 3/8	1 1/2	1/4	4	14.3	-	-	-	48	
<b>730 and 830 Series Cross Tees</b>												
Cross Tees	734	NA <sup>6</sup>	0.015	15/16	1 1/2	1/4	4	14.0	-	-	-	24
	734	NA <sup>6</sup>	0.015	15/16	1 1/2	1/4	4	9.5	-	-	-	48
	834	NA <sup>6</sup>	0.024	15/16	1 1/2	1/4	4	7.5	-	-	-	48
<b>1200 Series Cross Tees</b>												
Cross Tees <sup>5</sup>	1202	NA <sup>6</sup>	0.0085	15/16	1 5/16	1/4	2	16.5	-	-	-	24
	1204	NA <sup>6</sup>	0.020	15/16	1 1/2	1/4	4	17.0	-	-	-	24
	1206	NA <sup>6</sup>	0.015	15/16	1 1/2	1/4	5	-	7.5	-	-	30
	1210	NA <sup>6</sup>	0.0085	15/16	1 1/2	1/4	4	8.0	-	-	-	24
	1210	NA <sup>6</sup>	0.0085	15/16	1 1/2	1/4	4	4.5	-	-	-	48
	1214	NA <sup>6</sup>	0.013	15/16	1 1/2	1/4	4	10.6	-	-	-	24
	1214	NA <sup>6</sup>	0.013	15/16	1 1/2	1/4	4	8.0	-	-	-	48
	1228	NA <sup>6</sup>	0.008	15/16	1 1/2	1/4	4	8.0	-	-	-	24
	1236	NA <sup>6</sup>	0.014	15/16	1 1/2	1/4	6	8.0 <sup>7,10</sup>	-	-	-	72
	1236	NA <sup>6</sup>	0.014	15/16	1 1/2	1/4	6	10.6 <sup>7,10</sup>	-	-	-	24

**TABLE 1—ALLOWABLE LOADS FOR MEMBERS DESCRIBED IN SECTIONS 3.1 AND 3.4<sup>1, 2, 8, 9</sup> (Continued)**

Member	DIMENSIONS OF MEMBERS							SIMPLE SPAN				ALLOWABLE SPACING BETWEEN LATERAL BRACING (in)
	Catalog Number	ASTM C635 Duty Classification	Thickness (in)	Exposed Flange Width (in)	Height of Section (in)	Bulb Section Width (in)	Length of Section (ft)	Uniform Load (lb/ft)		Concentrated Load at Midspan (lb)		
								4-ft Span	5-ft Span	4-ft Span	5-ft Span	
1244	NA <sup>6</sup>	0.010	15/16	1 1/2	1/4	4	8.0	-	-	-	24	
1254	NA <sup>6</sup>	0.013	15/16	1 1/2	1/4	4	10.6	-	-	-	24	
1254	NA <sup>6</sup>	0.013	15/16	1 1/2	1/4	4	8.0	-	-	-	48	
1264	NA <sup>6</sup>	0.013	15/16	1 1/2	1/4	4	10.6	-	-	-	24	
1264	NA <sup>6</sup>	0.013	15/16	1 1/2	1/4	4	8.0	-	-	-	48	
1274	NA <sup>6</sup>	0.020	15/16	1 1/2	1/4	4	17.0	-	-	-	24	
1275	NA <sup>6</sup>	0.020	15/16	1 1/2	1/4	5	-	8.9	-	-	30	
1278	NA <sup>6</sup>	0.015	15/16	1 1/2	1/4	8	1.8 <sup>4</sup>	-	-	-	48	
1278	NA <sup>6</sup>	0.014	15/16	1 1/2	1/4	8	8.0 <sup>4,10</sup>	-	-	-	96	
1278	NA <sup>6</sup>	0.014	15/16	1 1/2	1/4	8	10.6 <sup>4,10</sup>	-	-	-	24	
1280	NA <sup>6</sup>	0.010	15/16	1 5/16	1/4	4	6.9	-	-	-	48	
1284	NA <sup>6</sup>	0.020	15/16	1 1/2	1/4	4	17.0	-	-	-	24	
1285	NA <sup>6</sup>	0.015	15/16	1 1/2	1/4	5	-	8.9	-	-	30	
1296	NA <sup>6</sup>	0.015	15/16	1 1/2	1/4	5	-	7.5	-	-	30	
<b>1800 Series Cross Tees</b>												
1804	NA <sup>6</sup>	0.020	15/16	1 1/2	1/4	4	16.0	-	41.7	-	24	
1804	NA <sup>6</sup>	0.020	15/16	1 1/2	1/4	4	16.0	-	32.5	-	48	
1805	NA <sup>6</sup>	0.015	15/16	1 1/2	1/4	5	-	7.3	-	15.0	30	
1805	NA <sup>6</sup>	0.015	15/16	1 1/2	1/4	5	-	6.5	-	15.0	60	
1814	NA <sup>6</sup>	0.015	15/16	1 1/2	1/4	4	12.6	-	30.5	-	24	
1814	NA <sup>6</sup>	0.015	15/16	1 1/2	1/4	4	9.0	-	24.0	-	48	
1834	NA <sup>6</sup>	0.015	15/16	1 1/2	1/4	4	12.6	-	30.5	-	24	
1834	NA <sup>6</sup>	0.015	15/16	1 1/2	1/4	4	10.8	-	20.0	-	48	
1854	NA <sup>6</sup>	0.015	15/16	1 1/2	1/4	4	12.6	-	30.5	-	24	
1854	NA <sup>6</sup>	0.015	15/16	1 1/2	1/4	4	9.0	-	24.0	-	48	
1855	NA <sup>6</sup>	0.015	15/16	1 1/2	1/4	5	-	6.5	-	15.0	60	
1864	NA <sup>6</sup>	0.015	15/16	1 1/2	1/4	4	12.6	-	30.5	-	24	
1864	NA <sup>6</sup>	0.015	15/16	1 1/2	1/4	4	10.8	-	20.0	-	48	
1874	NA <sup>6</sup>	0.020	15/16	1 1/2	1/4	4	16.0	-	41.7	-	24	
1874	NA <sup>6</sup>	0.020	15/16	1 1/2	1/4	4	16.0	-	32.5	-	48	
1874	NA <sup>6</sup>	0.020	15/16	1 1/2	1/4	4	17.3	-	-	-	24	
1865	NA <sup>6</sup>	0.015	15/16	1 1/2	1/4	5	-	6.6	-	12.0	60	
1875	NA <sup>6</sup>	0.020	15/16	1 1/2	1/4	5	-	7.0	-	20.0	60	
1884	NA <sup>6</sup>	0.020	15/16	1 1/2	1/4	4	16.0	-	-	-	48	
1885	NA <sup>6</sup>	0.020	15/16	1 1/2	1/4	5	-	9.0	-	-	30	
<b>3500 Series Cross Tees</b>												
3514	NA <sup>6</sup>	0.015	9/16	1 5/8	1/4	4	12.1	-	-	-	24	
3515	NA <sup>6</sup>	0.015	9/16	1 5/8	1/4	5	-	5.8	-	-	30	
3518	NA <sup>6</sup>	0.015	9/16	1 5/8	1/4	4	12.1	-	-	-	24	
3519	NA <sup>6</sup>	0.015	9/16	1 5/8	1/4	5	-	5.8	-	-	30	
3525	NA <sup>6</sup>	0.015	9/16	1 5/8	1/4	5	-	5.8	-	-	48	
3521	NA <sup>6</sup>	0.015	9/16	1 5/8	1/4	5	-	5.8	-	-	60	
3524	NA <sup>6</sup>	0.015	9/16	1 5/8	1/4	4	12.1	-	-	-	48	
3564	NA <sup>6</sup>	0.020	9/16	1 5/8	1/4	4	13.3	-	-	-	24	
3568	NA <sup>6</sup>	0.020	9/16	1 5/8	1/4	4	15.3	-	-	-	24	
<b>3600 Series Cross Tees</b>												
3614	NA <sup>6</sup>	0.015	9/16	1 5/8	1/4	4	12.1	-	-	-	24	
3615	NA <sup>6</sup>	0.015	9/16	1 5/8	1/4	5	-	5.8	-	-	30	
3618	NA <sup>6</sup>	0.015	9/16	1 5/8	1/4	4	12.1	-	-	-	24	
3619	NA <sup>6</sup>	0.015	9/16	1 5/8	1/4	5	-	5.8	-	-	30	
3621	NA <sup>6</sup>	0.015	9/16	1 5/8	1/4	5	-	5.8	-	-	60	
3624	NA <sup>6</sup>	0.015	9/16	1 5/8	1/4	4	12.1	-	-	-	48	
3625	NA <sup>6</sup>	0.015	9/16	1 5/8	1/4	5	-	5.8	-	-	48	
<b>3700 Series Cross Tees</b>												
3714	NA <sup>6</sup>	0.015	9/16	1 1/2	3/16	4	8.0	-	13.5	-	24	
3714	NA <sup>6</sup>	0.015	9/16	1 1/2	3/16	4	5.0	-	-	-	48	
3715	NA <sup>6</sup>	0.015	9/16	1 1/2	3/16	5	-	5.0	-	9.5	30	
3715	NA <sup>6</sup>	0.015	9/16	1 1/2	3/16	5	-	2.5	-	-	60	
3734	NA <sup>6</sup>	0.020	9/16	1 1/2	3/16	4	9.5	-	22.5	-	24	
3734	NA <sup>6</sup>	0.020	9/16	1 1/2	3/16	4	7.0	-	-	-	48	
3735	NA <sup>6</sup>	0.020	9/16	1 1/2	3/16	5	-	5.5	-	13.0	30	
3735	NA <sup>6</sup>	0.020	3/4	1 1/2	3/16	5	-	2.5	-	-	60	

**TABLE 1—ALLOWABLE LOADS FOR MEMBERS DESCRIBED IN SECTIONS 3.1 AND 3.4<sup>1, 2, 8, 9</sup> (Continued)**

Member	DIMENSIONS OF MEMBERS							SIMPLE SPAN				ALLOWABLE SPACING BETWEEN LATERAL BRACING (in)
	Catalog Number	ASTM C635 Duty Classification	Thickness (in)	Exposed Flange Width (in)	Height of Section (in)	Bulb Section Width (in)	Length of Section (ft)	Uniform Load (lb/ft)		Concentrated Load at Midspan (lb)		
								4-ft Span	5-ft Span	4-ft Span	5-ft Span	
<b>3800 Series Cross Tees</b>												
3814	NA <sup>6</sup>	0.015	3/4	1 1/2	3/16	4	9.5	-	20.5	-	24	
3814	NA <sup>6</sup>	0.015	3/4	1 1/2	3/16	4	6.5	-	18.0	-	48	
3815	NA <sup>6</sup>	0.015	3/4	1 1/2	3/16	5	-	4.5	-	19.0	30	
3815	NA <sup>6</sup>	0.015	3/4	1 1/2	3/16	5	-	3.5	-	10.5	60	
3834	NA <sup>6</sup>	0.018	3/4	1 1/2	3/16	4	10.0	-	21.0	-	24	
3834	NA <sup>6</sup>	0.018	3/4	1 1/2	3/16	4	7.0	-	18.5	-	48	
3835	NA <sup>6</sup>	0.018	3/4	1 1/2	3/16	5	-	5.5	-	13.0	30	
3835	NA <sup>6</sup>	0.018	3/4	1 1/2	3/16	5	-	4.5	-	10.5	60	
<b>4000 Series Cross Tees</b>												
4014C	NA <sup>6</sup>	0.018	9/16	1 1/2	1/4	4	12.5	-	-	-	24	
4015C	NA <sup>6</sup>	0.018	9/16	1 1/2	1/4	5	-	6.0	-	-	30	
4017C	NA <sup>6</sup>	0.018	9/16	1 1/2	1/4	6	6.0 <sup>7,10</sup>	-	-	-	72	
4017C	NA <sup>6</sup>	0.018	9/16	1 1/2	1/4	6	12.5 <sup>7,10</sup>	-	-	-	24	
4018C	NA <sup>6</sup>	0.018	9/16	1 1/2	1/4	8	6.0 <sup>4,10</sup>	-	-	-	96	
4018C	NA <sup>6</sup>	0.018	9/16	1 1/2	1/4	8	12.5 <sup>4,10</sup>	-	-	-	24	
4022C	NA <sup>6</sup>	0.0115	9/16	1 1/2	1/4	2	17.0	-	-	-	24	
4024C	NA <sup>6</sup>	0.012	9/16	1 1/2	1/4	4	7.5	-	-	-	24	
4054C	NA <sup>6</sup>	0.018	9/16	1 1/2	1/4	4	12.5	-	-	-	24	
<b>4200 Series Cross Tees</b>												
4202	NA <sup>6</sup>	0.0115	9/16	1 49/64	1/4	4	17.0	-	-	-	24	
4204	NA <sup>6</sup>	0.018	9/16	1 49/64	1/4	4	12.5	-	-	-	24	
<b>4500 Series Cross Tees</b>												
4514	NA <sup>6</sup>	0.015	9/16	1 25/32	1/4	4	14.6	-	-	-	24	
4515	NA <sup>6</sup>	0.015	9/16	1 25/32	1/4	5	-	4.35	-	-	60	
4516	NA <sup>6</sup>	0.015	9/16	1 25/32	1/4	6	4.6 <sup>7</sup>	-	-	-	24	
4516	NA <sup>6</sup>	0.014	9/16	1 25/32	1/4	6	13.1 <sup>7,10</sup>	-	-	-	72	
4516	NA <sup>6</sup>	0.014	9/16	1 25/32	1/4	6	14.6 <sup>7,10</sup>	-	-	-	24	
4518	NA <sup>6</sup>	0.015	9/16	1 25/32	1/4	4	14.6	-	-	-	24	
4519	NA <sup>6</sup>	0.015	9/16	1 25/32	1/4	5	-	4.35	-	-	60	
4521	NA <sup>6</sup>	0.015	9/16	1 25/32	1/4	5	-	4.35	-	-	60	
4524	NA <sup>6</sup>	0.015	9/16	1 25/32	1/4	4	13.1	-	-	-	48	
4528	NA <sup>6</sup>	0.014	9/16	1 25/32	1/4	8	13.1 <sup>4,10</sup>	-	-	-	96	
4528	NA <sup>6</sup>	0.014	9/16	1 25/32	1/4	8	14.6 <sup>4,10</sup>	-	-	-	24	
4564	NA <sup>6</sup>	0.015	9/16	1 25/32	1/4	4	14.6	-	-	-	24	
4568	NA <sup>6</sup>	0.015	9/16	1 25/32	1/4	4	14.6	-	-	-	24	
<b>4600 Series Cross Tees</b>												
4614	NA <sup>6</sup>	0.015	9/16	1 25/32	1/4	4	14.6	-	-	-	24	
4615	NA <sup>6</sup>	0.015	9/16	1 25/32	1/4	5	-	4.35	-	-	60	
4616	NA <sup>6</sup>	0.015	9/16	1 25/32	1/4	6	4.6 <sup>7</sup>	-	-	-	24	
4616	NA <sup>6</sup>	0.014	9/16	1 25/32	1/4	6	13.1 <sup>7,10</sup>	-	-	-	72	
4616	NA <sup>6</sup>	0.014	9/16	1 25/32	1/4	6	14.6 <sup>7,10</sup>	-	-	-	24	
4618	NA <sup>6</sup>	0.015	9/16	1 25/32	1/4	4	14.6	-	-	-	24	
4619	NA <sup>6</sup>	0.015	9/16	1 25/32	1/4	5	-	4.35	-	-	60	
4621	NA <sup>6</sup>	0.015	9/16	1 25/32	1/4	5	-	4.35	-	-	60	
4624	NA <sup>6</sup>	0.015	9/16	1 25/32	1/4	4	13.1	-	-	-	48	
4628	NA <sup>6</sup>	0.014	9/16	1 25/32	1/4	8	13.1 <sup>4,10</sup>	-	-	-	96	
4628	NA <sup>6</sup>	0.014	9/16	1 25/32	1/4	8	14.6 <sup>4,10</sup>	-	-	-	24	

For SI: 1 in = 25.4 mm, 1 ft = 304.8 mm, 1 lb/ft = 14.59 N/m.

<sup>1</sup>Loads indicated are to include the weight of the system as well as the superimposed loads, and are based on ultimate strength divided by a factor of safety of 2 or a L/360 Deflection, whichever governs.

<sup>2</sup>When loading any system uniformly, the weight in pounds per square ft may not exceed the strength of its weakest member. Individual members are to be checked for possible overload from concentrated loads in excess of those tabulated.

<sup>3</sup>The first value applies to 4-ft spans. The second value applies to 5-ft spans.

<sup>4</sup>Uniform load applies to 8-ft-long span.

<sup>5</sup>Cross tees shorter than 4 ft are permitted the same simple span uniform or concentrated loads as those for the 4-ft-long cross tees of equivalent size and thickness.

<sup>6</sup>Not applicable – Applies only to main runners with a 4-ft span.

<sup>7</sup>Uniform load applies to a 6-ft span.

<sup>8</sup>Cross tees 4512 and 4562 are 2 feet long and have the same material and cross-sectional dimensions as those of cross tee 4514.

<sup>9</sup>Cross tees 4612 are 2 feet long and have the same material and cross-sectional dimensions as that of cross tee 4614. Refer to footnote 5 for load rating.

<sup>10</sup>Load Values are based on the use of a midspan hanger wire support.

TABLE 2—ALLOWABLE LOADS FOR MEMBERS DESCRIBED IN SECTION 3.2<sup>1, 2</sup>

MEMBER	MEMBER DESCRIPTION (MATERIALS AND DIMENSIONS)								SIMPLE SPAN	ALLOWABLE SPACING BETWEEN LATERAL BRACING (inches)
	Model Number	ASTM C635 Duty Classification	Material <sup>5</sup>	Base-Metal Thickness (inch)	Exposed Flange Width (FW) (inch)	Height of Section (M) (inches)	Bulb Section Width (BW) (inch)	Length of Section (feet)	Allowable Uniform Load (pounds per foot)	
									4-foot-span	
Main Runner	10-00-830	Light	AL	0.024	<sup>15</sup> / <sub>16</sub>	1 <sup>1</sup> / <sub>2</sub>	<sup>1</sup> / <sub>4</sub>	12	7.4	48
	55.39.112	Heavy	STL	0.020	<sup>15</sup> / <sub>16</sub>	1 <sup>1</sup> / <sub>2</sub>	<sup>1</sup> / <sub>4</sub>	12	17	24
	MA010.500CH	Heavy	STL	0.020	<sup>15</sup> / <sub>16</sub>	2 <sup>3</sup> / <sub>32</sub>	<sup>1</sup> / <sub>4</sub>	12	23.7	48
	10-04-000-C	Intermediate	STL	0.018	<sup>9</sup> / <sub>16</sub>	1 <sup>1</sup> / <sub>2</sub>	<sup>1</sup> / <sub>4</sub>	12	12.6	24
	10-04-000-A-C	Intermediate	STL	0.018	<sup>9</sup> / <sub>16</sub>	1 <sup>1</sup> / <sub>2</sub>	<sup>1</sup> / <sub>4</sub>	12	12.6	24
Cross-Tee <sup>3</sup>	10-00-834	NA	AL	0.024	<sup>15</sup> / <sub>16</sub>	1 <sup>1</sup> / <sub>2</sub>	<sup>1</sup> / <sub>4</sub>	4	7.4	24
	55.39.004	NA	STL	0.020	<sup>15</sup> / <sub>16</sub>	1 <sup>1</sup> / <sub>2</sub>	<sup>1</sup> / <sub>4</sub>	4	16.8	24
	10-04-024-C <sup>4</sup>	-	STL	-	-	-	-	-	-	-
	10-04-014-C	NA	STL	0.018	<sup>9</sup> / <sub>16</sub>	1 <sup>1</sup> / <sub>2</sub>	<sup>1</sup> / <sub>4</sub>	4	12.5	24
	10-04-014-A-C	NA	STL	0.018	<sup>9</sup> / <sub>16</sub>	1 <sup>1</sup> / <sub>2</sub>	<sup>1</sup> / <sub>4</sub>	4	12.5	24

For SI: 1 inch = 25.4 mm, 1 foot = 305 mm, 1 lb./ft. = 14.59 N/m.

NA = Not applicable.

<sup>1</sup>Loads indicated are to include the weight of the system as well as the superimposed loads, and are based on ultimate strength divided by a factor of safety of 2, or an L/360 deflection, whichever governs.

<sup>2</sup>When loading any system uniformly, the weight in pounds per square foot may not exceed the strength of its weakest member. Individual members are to be checked for possible overload from concentrated loads in excess of those tabulated.

<sup>3</sup>Cross tees shorter than 4 feet are permitted the same simple span uniform or concentrated loads as those used for the 4-foot-long cross tees of equivalent size and thickness.

<sup>4</sup>See 4024C cross tee in [Table 1](#) for product dimensions, allowable load and allowable spacing between lateral bracing.

<sup>5</sup>Material types: AL = Aluminum; STL = Steel.



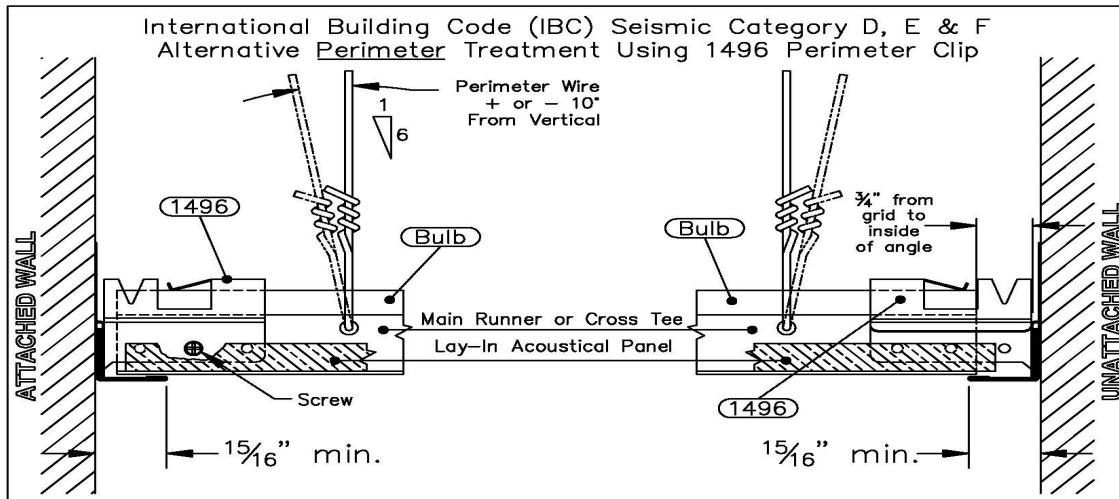

FIGURE 2<sup>1</sup>

<sup>1</sup>Mid-span support using 12 gauge wire for 6 feet and 8 feet long cross tees not shown.

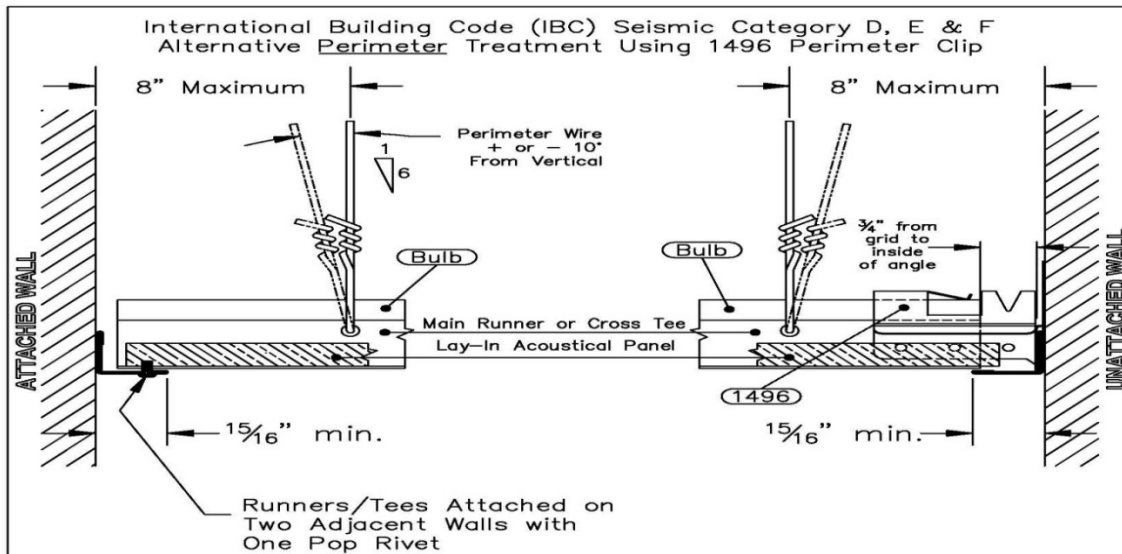

FIGURE 3

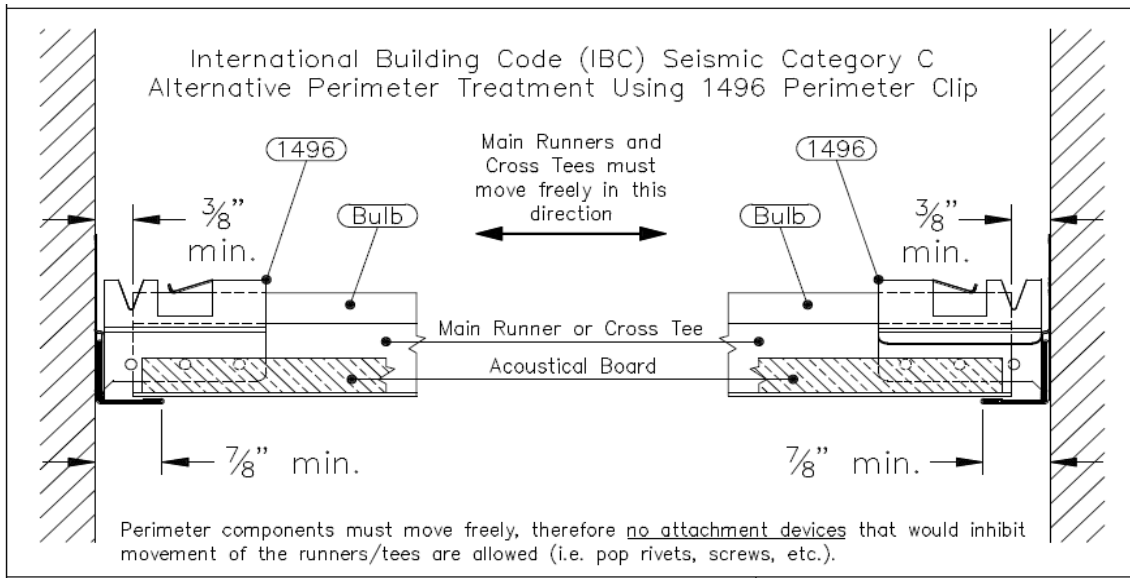

FIGURE 4

International Building Code (IBC) Seismic Category D, E & F  
Alternative Perimeter Treatment Using 1496 Perimeter Clip  
Detail for allowable ceiling weight of 4.0 PSF

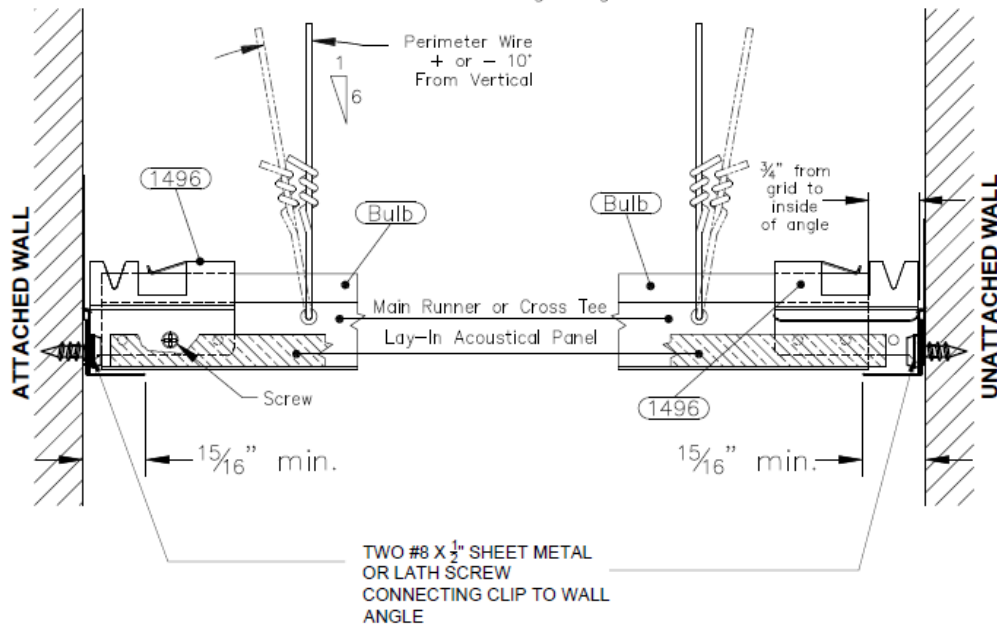

FIGURE 5

International Building Code (IBC) Seismic Category D, E & F  
 Alternative Perimeter Treatment Using 1496 Perimeter Clip  
 Detail for allowable ceiling weight of 4.0 PSF

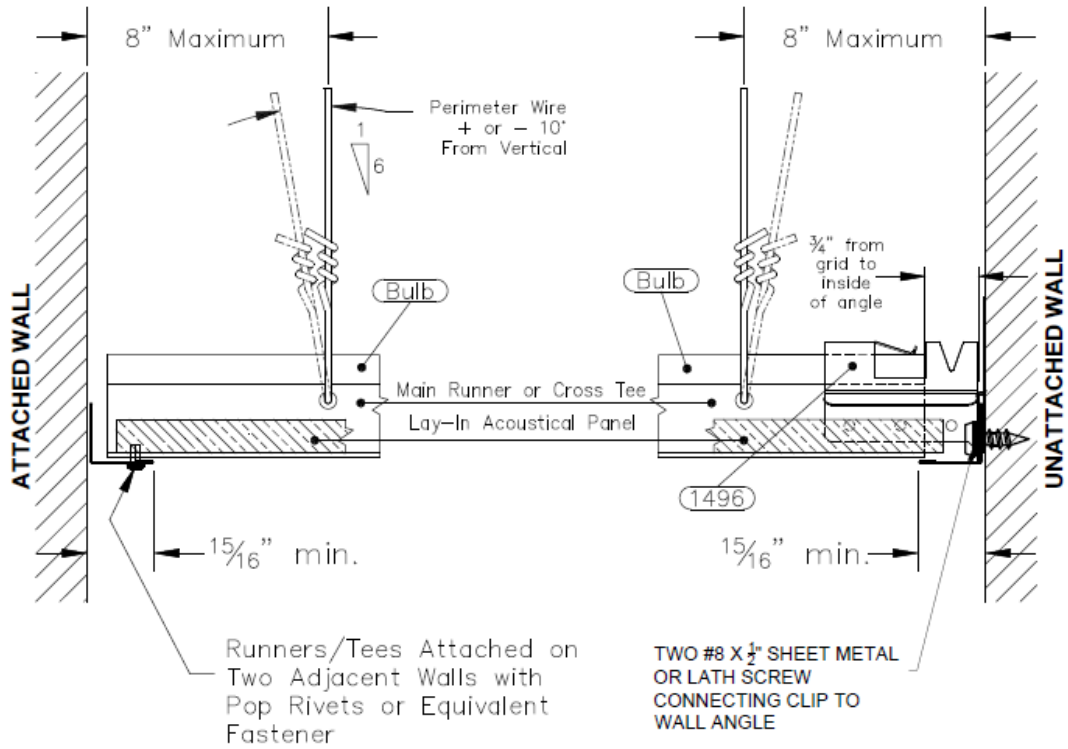

FIGURE 6

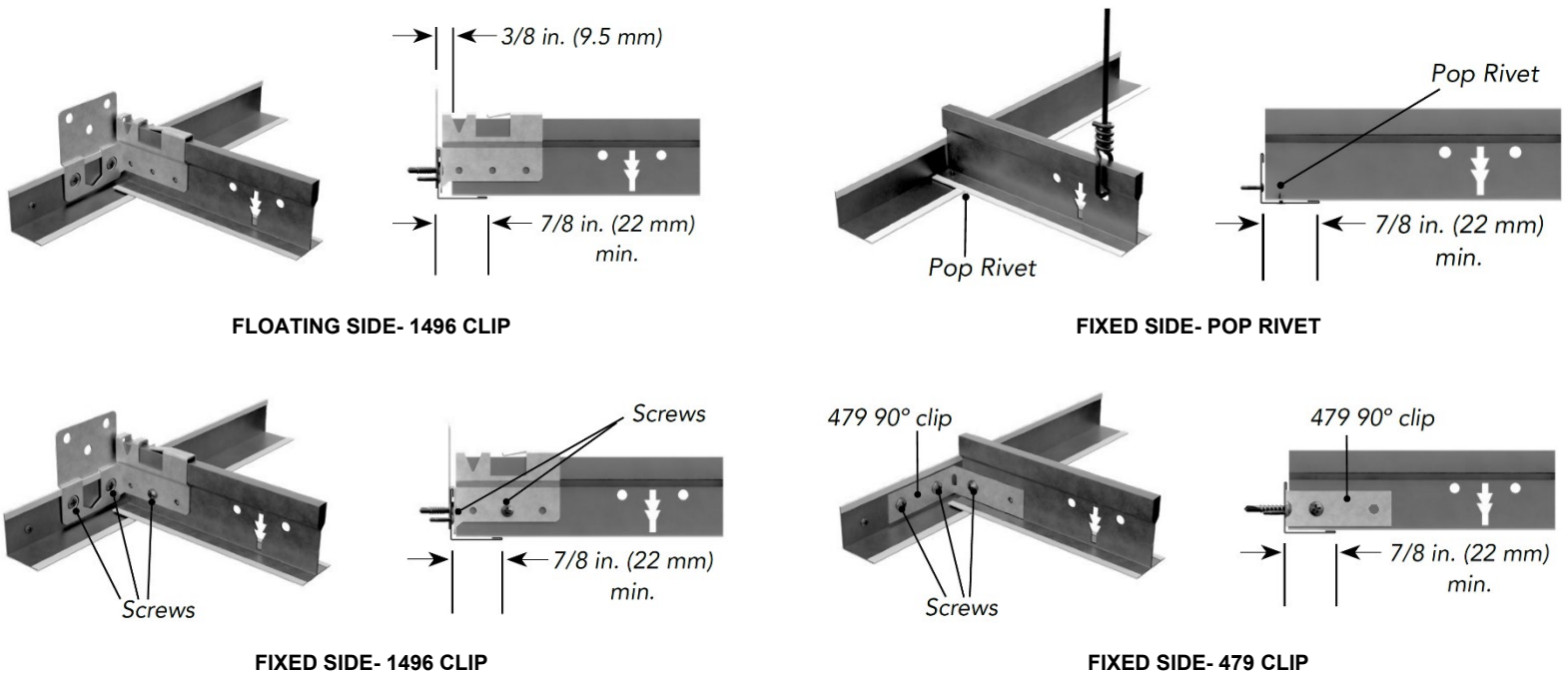

FIGURE 7—SEISMIC DESIGN CATEGORY C (SECTION 4.2.4)

**DIVISION: 09 00 00—FINISHES**  
**Section: 09 22 26—Suspension Systems**  
**Section: 09 53 00—Acoustical Ceiling Suspension Assemblies**

**REPORT HOLDER:**

ROXUL USA INC. d/b/a ROCKFON

**EVALUATION SUBJECT:****ROCKFON® CHICAGO METALLIC™ SUSPENDED CEILING FRAMING SYSTEMS AND SUSPENDED CEILING SYSTEMS****1.0 REPORT PURPOSE AND SCOPE****Purpose:**

The purpose of this evaluation report supplement is to indicate that the ROCKFON® CHICAGO METALLIC™ suspended ceiling framing systems and suspended ceiling systems, described in ICC-ES evaluation report [ESR-2631](#), have also been evaluated for compliance with the codes noted below as adopted by the Los Angeles Department of Building and Safety (LADBS).

**Applicable code edition:**

- 2020 *City of Los Angeles Building Code* (LABC)

**2.0 CONCLUSIONS**

The ROCKFON® CHICAGO METALLIC™ suspended ceiling framing systems and suspended ceiling systems, described in Sections 2.0 through 7.0 of the evaluation report [ESR-2631](#), comply with the LABC Chapters 8, 16 and 25, and are subjected to the conditions of use described in this supplement.

**3.0 CONDITIONS OF USE**

The ROCKFON® CHICAGO METALLIC™ suspended ceiling framing systems and suspended ceiling systems described in this evaluation report must comply with all of the following conditions:

- All applicable sections in the evaluation report [ESR-2631](#).
- The design, installation, conditions of use and identification of the ROCKFON® CHICAGO METALLIC™ suspended ceiling framing systems and suspended ceiling systems are in accordance with the 2018 *International Building Code*® (IBC) provisions noted in the evaluation report [ESR-2631](#).
- The design, installation and inspection are in accordance with additional requirements of LABC Chapters 16, 17 and 25, as applicable.
- Main runners shall be identified by indentation or by nontransferable decal with letter not less than 1/4-inch high and shall include manufacturer's name and runner designation.

This supplement expires concurrently with the evaluation report, reissued June 2024 and revised April 2025.



**DIVISION: 09 00 00—FINISHES**  
**Section: 09 22 26—Suspension Systems**  
**Section: 09 53 00—Acoustical Ceiling Suspension Assemblies**

**REPORT HOLDER:**

ROXUL USA INC. d/b/a ROCKFON

**EVALUATION SUBJECT:****ROCKFON® CHICAGO METALLIC™ SUSPENDED CEILING FRAMING SYSTEMS AND SUSPENDED CEILING SYSTEMS****1.0 REPORT PURPOSE AND SCOPE****Purpose:**

The purpose of this evaluation report supplement is to indicate that the ROCKFON® CHICAGO METALLIC™ suspended ceiling framing systems, described in ICC-ES evaluation report ESR-2631, have also been evaluated for compliance with the codes noted below.

**Applicable Code Edition:**

- 2022 and 2019 *California Building Code (CBC)*

For evaluation of applicable chapters adopted by the California Office of Statewide Health Planning and Development (OSHPD) AKA: California Department of Health Care Access and Information (HCAI) and the Division of State Architect (DSA), see Sections 2.1 and 2.2 below.

**2.0 CONCLUSIONS**

The ROCKFON® CHICAGO METALLIC™ suspended ceiling framing systems, described in Sections 2.0 through 7.0 of the evaluation report ESR-2631, comply with CBC Chapters 8, 16 and 25, provided the design and installation are in accordance with the 2021 and 2018 International Building Code (IBC) provisions, as applicable, noted in the evaluation report, and the additional requirements of CBC Chapters 8, 16, 17 and 25, as applicable.

**2.1 OSHPD:**

The ROCKFON® CHICAGO METALLIC™ suspended ceiling framing systems, described in Section 2.0 through 7.0 of the evaluation report ESR-2631, comply with CBC Chapters 8, 16, 17 and 25, with applicable amendments, and Chapters 16A and 17A, provided the design and installation are in accordance with the 2021 and 2018 International Building Code (IBC) provisions noted in the evaluation report, and the additional requirements in Sections 2.1.1 through 2.1.2 of this supplement:

**2.1.1 Conditions of Use:**

1. All loads applied shall be determined by a registered structural engineer and shall comply with applicable loads from CBC Chapter 16 and its amendments, and Chapter 16A.
2. Section 13.5.6.2 of ASCE 7 shall be revised in accordance with CBC Section 1617A.1.21 [OSHPD 1 & 4].
3. Design and installation shall comply with the requirements of OSHPD Preapproved Details (OPD) OPD-0002-13 and OPD-0003-13 as applicable.

**2.1.2 Special Inspection Requirements:**

1. Periodic special inspection is required, in accordance with Section 1705A.13.5 of the 2022 CBC [OSHPD 1 & 4], and Section 1705A.12.5 of the 2019 CBC [OSHPD 1 & 4], as applicable.

2. Where gypsum wallboard is used in suspended ceiling installations, additional inspection shall be in accordance with CBC Section 2503.2 of the 2022 CBC [OSHPD 1, 1R, 2, 3, 4 & 5] and 2019 CBC [OSHPD 1, 1R, 2, 4 & 5].

## **2.2 DSA:**

The ROCKFON® CHICAGO METALLIC™ suspended ceiling framing systems, described in Section 2.0 through 7.0 of the evaluation report ESR-2631, comply with CBC Chapters 8, 16, 17 and 25, with applicable amendments, and Chapters 16A and 17A, provided the design and installation are in accordance with the 2021 and 2018 International Building Code (IBC) provisions noted in the evaluation report, and the additional requirements in Sections 2.2.1 through 2.2.2 of this supplement:

### **2.2.1 Conditions of Use:**

1. All loads applied shall be determined by a registered structural engineer and shall comply with applicable loads from CBC Chapter 16 and its amendments, and Chapter 16A.
2. Section 13.5.6.2 of ASCE 7 shall be revised in accordance with CBC Section 1617.11.16 [DSA-SS/CC] and Section 1617A.1.21 [DSA-SS].
3. Design and installation shall comply with the requirements of DSA Interpretation of Regulations (IR) DSA IR 25-2.19 and DSA IR 25-3.19 as applicable.

### **2.2.2 Special Inspection Requirements:**

1. Periodic special inspection is required, in accordance with Section 1705A.13.5 of the 2022 CBC [DSA-SS & DSA-SS/CC] and Section 1705A.12.5 of the 2019 CBC [DSA-SS & DSA-SS/CC], as applicable.
2. Where gypsum wallboard is used in suspended ceiling installations, additional inspection shall be in accordance with CBC Section 2503.2 [DSA-SS, DSA-SS/CC].

This supplement expires concurrently with the evaluation report, reissued June 2024 and revised April 2025.