

ICC-ES Evaluation Report

ESR-2671

Reissued February 2025

This report also contains:

- [CA Supplement](#)

Subject to renewal February 2027

ICC-ES Evaluation Reports are not to be construed as representing aesthetics or any other attributes not specifically addressed, nor are they to be construed as an endorsement of the subject of the report or a recommendation for its use. There is no warranty by ICC Evaluation Service, LLC, express or implied, as to any finding or other matter in this report, or as to any product covered by the report.

Copyright © 2025 ICC Evaluation Service, LLC. All rights reserved.

<p>DIVISION: 09 00 00— FINISHES</p> <p>Section: 09 24 00— Portland Cement Plastering</p>	<p>REPORT HOLDER:</p> <p>CTS CEMENT MANUFACTURING CORPORATION</p>	<p>EVALUATION SUBJECT:</p> <p>RAPID SET ONE COAT STUCCO SYSTEM</p>	
--	---	--	---

1.0 EVALUATION SCOPE

Compliance with the following codes:

- 2018, 2015, 2012, 2009 and 2006 [International Building Code® \(IBC\)](#)
- 2018, 2015, 2012, 2009 and 2006 [International Residential Code® \(IRC\)](#)
- 2013 *Abu Dhabi International Building Code (ADIBC)*[†]

[†]The ADIBC is based on the 2009 IBC. 2009 IBC code sections referenced in this report are the same sections in the ADIBC.

Properties evaluated:

- Structural
- Durability
- Fire-resistance-rated construction
- Noncombustible construction

2.0 USES

The Rapid Set One Coat Stucco System is an exterior wall covering for installation on exterior walls of wood or steel framed construction, or masonry or concrete construction.

3.0 DESCRIPTION

3.1 General:

The Rapid Set One Coat Stucco System includes Rapid Set Stucco, an exterior cementitious coating reinforced with wire fabric or metal lath and applied over substrates of fiberboard, plywood, or gypsum sheathing on wood or steel framed walls, or applied directly to masonry or concrete construction without the wire fabric or metal lath.

3.2 Materials:

3.2.1 Rapid Set Stucco Mix: Rapid Set Stucco Mix is a factory-prepackaged mixture of Rapid Set Eisenwall Cement and graded sand, packaged in 55-pound (25 kg) bags. Each bag of Rapid Set Stucco Mix is jobsite-mixed with approximately 3¹/₂ quarts (3.3 L) of water in accordance with the manufacturer’s recommendations.

As an alternate, the Rapid Set Stucco may also be a jobsite mixture of 88-pound (40 kg) bags of Rapid Set Eisenwall Cement mixed with approximately 3 gallons (11.3 L) of water and 3 to 4 cubic feet (0.085 to 0.115 m³) of graded sand complying with Section 3.2.3 of this report, the whole mixed in accordance with the manufacturer's instructions.

3.2.2 Rapid Set Eisenwall Cement: The Rapid Set Eisenwall Cement is a proprietary cement packaged in 88-pound (40 kg) bags.

3.2.3 Sand: Sand must be clean and free from deleterious amounts of loam, clay, silt, soluble salts, and organic matter. Sampling and testing must comply with ASTM C144 or ASTM C897. Sand must be graded in accordance with ASTM C144, ASTM C897, or within the limits shown in the following table:

RETAINED ON U.S. STANDARD SIEVE	PERCENT RETAINED BY WEIGHT \pm 2 PERCENT	
	Minimum	Maximum
No. 4 (7.6 mm)	—	0
No. 8 (2.4 mm)	0	10
No. 16 (1.2 mm)	10	40
No. 30 (600 Φ m)	30	65
No. 50 (300 Φ m)	70	90
No. 100 (150 Φ m)	95	100

3.2.4 Lath: Wire fabric lath and metal lath must comply with the requirements of the applicable code for three-coat exterior plaster. Lath must be self-furred or furred when applied over all supports and substrates.

3.2.5 Wood Structural Panel Sheathing: Minimum $\frac{5}{16}$ -inch-thick (7.9 mm) plywood panels for studs spaced 16 inches on center (406 mm) and minimum $\frac{3}{8}$ -inch-thick (610 mm) panels for studs spaced 24 inches (9.5 mm) on center. Panels must be exterior-grade or Exposure 1 plywood complying with U.S. Department of Commerce Product Standard PS-1.

3.2.6 Gypsum Board: Water-resistant core-treated gypsum sheathing must comply with ASTM C79 or ASTM C1396.

3.2.7 Fiberboard: Minimum $\frac{1}{2}$ -inch-thick (12.7 mm) asphalt-impregnated fiberboard complying with ASTM C208 as a regular-density sheathing.

3.2.8 Caulking: Acrylic latex caulking material must comply with ASTM C834.

3.2.9 Weather Protection:

3.2.9.1 Water-resistive Barrier: A water-resistive barrier is required and must comply with 2018 IBC Section 1403.2 (2015, 2012, 2009 and 2006 IBC Section 1404.2) or IRC Section R703.2, as applicable. The barrier must be a minimum of one layer of No. 15 asphalt nonperforated felt complying as Type I, or a water-resistive barrier recognized as equivalent to ASTM D226 (IBC or IRC) or material recognized in a current ICC-ES evaluation report as complying with the ICC-ES Acceptance Criteria for Water-resistive Barriers (AC38).

When applied over wood-based sheathing, the barrier must be a minimum of two layers of Grade D kraft building paper as set forth in 2012, 2009 and 2006 IBC Section 2510.6, or 2018 and 2015 IRC Section R703.7.3 (2012, 2009 and 2006 IRC Section R703.6.3). A minimum of two layers of water-resistive barrier complying with ASTM E2566 Type 1, as set forth in the 2018 and 2015 IBC Section 2510.6.

3.2.9.2 Vapor Retarder: Under the IBC, protection against condensation must be provided in accordance with 2018 IBC Section 1402.2 (2015, 2012, 2009 and 2006 IBC Section 1403.2). Under the IRC, a vapor retarder complying with 2018, 2015 and 2012 IRC Section R702.7 (2009 IRC Section R601.3 or 2006 IRC Section R318.1) must be provided, as applicable, unless its omission is permitted under the exceptions to 2018, 2015 and 2012 IRC Section R702.7, 2009 IRC Section R601.3 or 2006 IRC Section R318.1.

3.2.10 Trim and Accessories: All trim, screeds and corner reinforcement must be galvanized steel or approved plastic.

4.0 INSTALLATION

4.1 General:

The water-resistive barrier is applied as set forth in Section 3.2.9. The lath must be applied tightly, with minimum 2-inch (51 mm) end and side laps, and fastened through the water-resistive barrier to wood studs and sills and plates, using fasteners and fastener spacing complying with ASTM C1063 as referenced in Sections 2510.3 and 2510.4 of the IBC or the 2018 and 2015 IRC Sections R703.7 and R703.7.1 (2012, 2009 and 2006 IRC Sections R703.6, and R703.6.1). Care must be taken to avoid overdriving fasteners. Fasteners for lath must penetrate a minimum of 1 inch (25.4 mm) into wood or steel studs. Flashing, corner reinforcement, and metal trim and weep screeds must be installed as shown in [Figure 1](#). The exterior cementitious coating must be applied by hand-troweling in one coat to a $\frac{3}{4}$ -inch to 1-inch (19.1 mm to 25.4 mm) thickness. Alternatively, the coating may be applied in two coats with the second coat applied as soon as the first coat has attained sufficient rigidity to receive the second coat, in accordance with Section 2512.8 of the IBC. An installation card, as shown in [Figure 2](#), must be completed, and signed by the applicator. The coating must be applied at ambient temperatures ranging from 32°F to 110°F (0°C to 43°C) by applicators approved by CTS Cement Manufacturing Corporation. The lath must be embedded in the minimum coating thickness and be unexposed. The finish coat may be applied after the base coat has cured one hour.

4.2 Application over Open Framing:

The water-resistive barrier must be applied, as set forth in Section 3.2.9.1 of this report, over open wood framing spaced a maximum of 24 inches (610 mm) on center.

The lath must be fastened to wood studs through the water-resistive barrier as set forth in Section 4.1 of this report. Care must be taken to avoid overdriving fasteners.

Wall bracing in accordance with the 2018 and 2015 IBC Section 2308.6 (2012, 2009 and 2006 IBC Section 2308.9.3) or IRC Section R602.10, as applicable, or an acceptable alternate, is required. Outside wall corners and parapet corners must be covered with extra metal corner reinforcements attached to the framing members with approved fasteners spaced 18 inches (457 mm) on center, or as necessary to hold plumb. Weep screeds must comply with, and be installed at the bottom of the wall in accordance with, IBC Section 2512.1.2, or 2018 and 2015 IRC Section R703.7.2.1 (2012, 2009 and 2006 IRC Section R703.6.2.1), as applicable. Galvanized steel, $1\frac{3}{8}$ -inch-thick (34.9 mm), No. 22 gage [0.025-inch-thick (0.635 mm)] trim pieces must be installed at other areas where sheathing is exposed. See [Figure 1](#) for typical installation details. At windows and doors, butting J-trim metal edges, when installed, must be caulked. Holes for hose bibbs, electrical panels and other penetrations of substrate surfaces, except those caused by fasteners, must also be caulked. The coating must then be applied as described in Section 4.1.

4.3 Application over Solid Backing:

4.3.1 Fiberboard: Minimum $\frac{1}{2}$ -inch-thick (12.7 mm) fiberboard sheathing must be installed directly over wood studs spaced a maximum of 24 inches (610 mm) on center. The fiberboard must be temporarily held in place with corrosion-resistant staples or roofing nails. A water-resistive barrier, as set forth in Section 3.2.9.1 of this report, must be applied over the fiberboard prior to application of lath. The lath must then be attached to studs through the water-resistive barrier and fiberboard sheathing with the fasteners and spacings described in Section 4.1 of this report or as described for fiberboard in 2018 and 2015 IBC Table 2304.10.1 (2012, 2009 and 2006 IBC Table 2304.9.1) or Table R602.3 (1) of the IRC, whichever is more restrictive. All walls must be braced in accordance with the applicable code. Exposed sheathing edges must be protected with screeds. Holes in the substrate surface must be caulked and the coating applied as described in Section 4.1 of this report.

4.3.2 Gypsum Sheathing: Minimum $\frac{1}{2}$ -inch-thick (12.7 mm), water-resistant core gypsum sheathing must be installed directly on wood studs spaced at a maximum of 24 inches (610 mm) on center, in a manner similar to the installation for fiberboard. Gypsum sheathing must be fastened in accordance with ASTM C1280 (under the IBC), or Table R702.3.5 of the IRC. The water-resistive barrier must be installed over the gypsum sheathing prior to installation of the lath and coating as described in Section 4.1 of this report. The sheathing is also permitted to be applied to minimum No. 20 gage [0.035 inch (0.9 mm) minimum base-metal thickness] steel studs spaced at a maximum of 24 inches (610 mm) on center. The gypsum sheathing must be attached to the steel studs with screws complying with ASTM C954 in accordance with ASTM C1280 (under the IBC), or Section R702.3.5.1 of the 2018 and 2015 IRC (Section R702.3.6 of the 2012, 2009 and 2006 IRC). The water-resistive barrier must be temporarily fastened, and must be followed by the self-furring or furred lath. The lath must be attached through the water-resistive barrier and gypsum sheathing to steel studs as set forth in Section 4.1 of this report. Screws fastening sheathing and screws fastening lath must be staggered from each other.

4.3.3 Wood-based Structural Panels: Plywood panels must be applied directly to wood studs under the conditions set forth in Section 3.2.5 of this report and either Table 2308.6.3(3) of the 2018 and 2015 IBC (Table 2308.9.3(3) of the 2012, 2009 and 2006 IBC) or Table R602.3(3) of the IRC, as applicable. The panels must be attached in accordance with Table 2304.10.1 of the 2018 and 2015 IBC (Table 2304.9.1 of the 2012, 2009 and 2006 IBC) or Table R602.3(1) of the IRC, as applicable. The water-resistive barrier, wire-fabric lath and coating must be applied as described for fiberboard in Section 4.3.1.

4.3.4 Concrete or Masonry: The concrete or masonry surface must be prepared according to Section 2510.7 of the IBC. The application of Rapid Set stucco directly to the concrete or masonry without the plaster reinforcement must be in accordance with Section 4.1 of this report.

4.4 Fire-resistance-rated construction:

Rapid Set Stucco may be used in fire-resistance-rated construction described in Table 721.1 (2) of the 2018, 2015 and 2012 IBC (Table 720.1 (2) of the 2009 and 2006 IBC), replacing the cement plaster identified in items 15-1.2, 15-1.3, 15-1.4, 15-1.7, and 15-1.8.

4.5 Miscellaneous:

4.5.1 Inspection Requirements: Building department inspection is required on lath installation prior to application of the coating as noted in 2018, 2015, 2012 or 2009 IBC Section 110.3.5 for jurisdictions adopting the 2018, 2015, 2012 or 2009 IBC or IRC, or 2006 IBC Section 109.3.5 for jurisdictions adopting the 2006 IBC or IRC.

4.5.2 Control Joints: Control joints must be installed as specified by the architect, designer, builder, or exterior coating manufacturer, in that order. In the absence of details, conventional three-coat plastering details must be used.

4.5.3 Curing: Moist curing must be provided for one hour after application by misting or light spraying, before application of the finish coat.

4.5.4 Soffits: The system may be applied to soffits, provided the coating is applied over metal lath complying with Section 3.2.4 of this report in lieu of wire fabric lath. Expanded metal lath fastening must comply with IBC Section 2510.3 or 2018 and 2015 IRC Section R703.7.1 (2012, 2009 and 2006 IRC Section R703.6.1), as applicable, except that the fastener length must be increased by the thickness of any substrate.

4.5.5 Sills: The system may be applied to sills at locations such as windows and similar areas. Sills with depths of 6 inches (152 mm) or less may have the coating and lath applied to any substrate permitted in this report, provided the **coating**, lath, water-resistant barrier and substrate are installed in accordance with the applicable sections of this report. Sills with depths exceeding 6 inches (152 mm) must have substrates of solid wood or plywood. The substrate must be fastened in accordance with the 2018 and 2015 IBC Table 2304.10.1 (2012, 2009 and 2006 IBC Table 2304.9.1) or IRC Table R602.3 (1), as applicable, and a double layer of Grade D water-resistive barrier must be applied over the substrate. The lath and coating must be applied in accordance with Section 4.1 of this report.

4.5.6 Deflection: The deflection of structural wall components, such as wood studs, concrete, or masonry, must be limited to a maximum of $1/240$ of the span.

5.0 CONDITIONS OF USE:

The Rapid Set One Coat Stucco System described in this report complies with, or is a suitable alternative to what is specified in, those codes listed in Section 1.0 of this report, subject to the following conditions:

- 5.1** The materials and methods of installation must comply with this report and the manufacturer's published installation instructions. In the event of a conflict between this report and the manufacturer's published installation instructions, this report governs.
- 5.2** Installation must be by applicators approved by the manufacturer.
- 5.3** The system must be limited to Type V construction or construction permitted by the IRC, when applied over wood or steel framing.
- 5.4** When the system is applied to noncombustible concrete or masonry surfaces, the walls retain the noncombustible rating.

- 5.5 The system must be limited to non-fire-resistance-rated construction except as described in Section 4.4 of this report.
- 5.6 An installation card, as shown in [Figure 2](#), must be left at the jobsite for the owner, and a copy must be filed with the building department.
- 5.7 When foam plastic plant-ons are used, the interior of the building must be separated from the foam plastic plant-on with a thermal barrier complying with the applicable code, such as 1/2-inch-thick (12.7 mm) regular gypsum wallboard mechanically attached in accordance with the applicable code.

6.0 EVIDENCE SUBMITTED

Data in accordance with applicable portions of the [ICC-ES Acceptance Criteria for Cementitious Exterior Wall Coatings \(AC11\)](#), dated January 2013 (editorially revised May 2018).

7.0 IDENTIFICATION

- 7.1 The Eisenwall cement and Rapid Set Stucco factory-prepared mixes are delivered to the jobsite in water-resistant bags with labels bearing the following information:
 1. Name and address of the manufacturer, and the evaluation report number (ESR-2671).
 2. Product designation.
 3. Weight of packaged mix.
 4. Storage instructions.
 5. Curing instructions.

- 7.2 The report holder's contact information is the following:

CTS CEMENT MANUFACTURING CORPORATION
12442 KNOTT STREET
GARDEN GROVE, CALIFORNIA 92841
(800) 929-3030
www.ctscement.com
info@ctscement.com

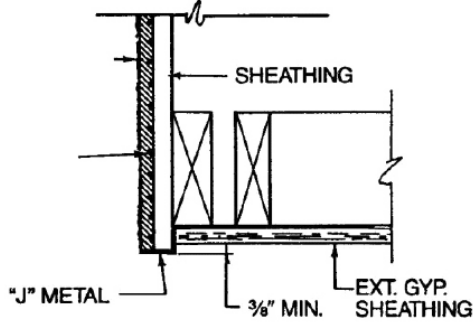

WOOD SOFFIT DETAIL

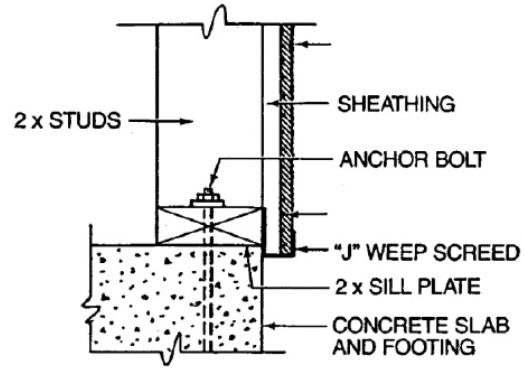

SILL FLASHING

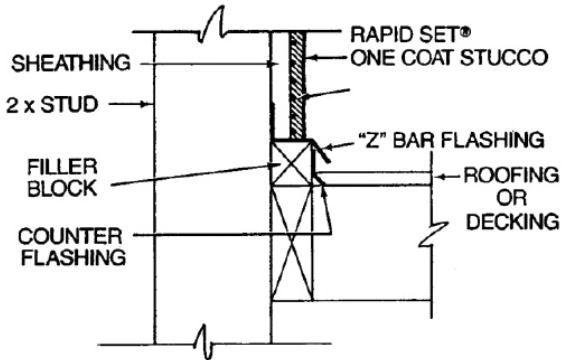

GABLE OR DECK FLASHING

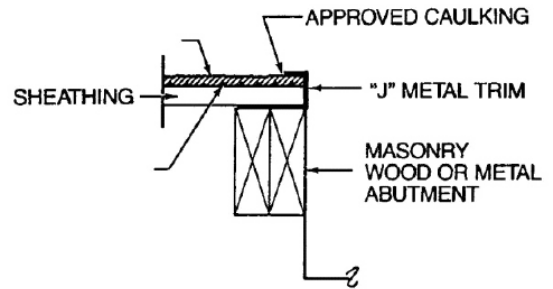

PLASTER GROUND

NOTE: WHEN PROPER PLASTER GROUND OR NAIL-ON FLANGE ARE NOT PROVIDED USE PLASTER GROUND DETAIL.

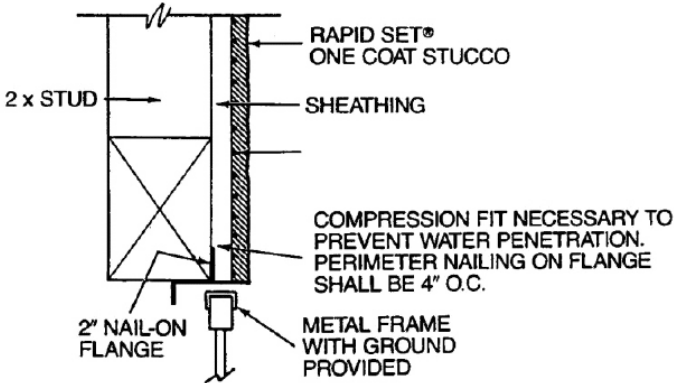

COMPRESSION FIT-METAL FRAME

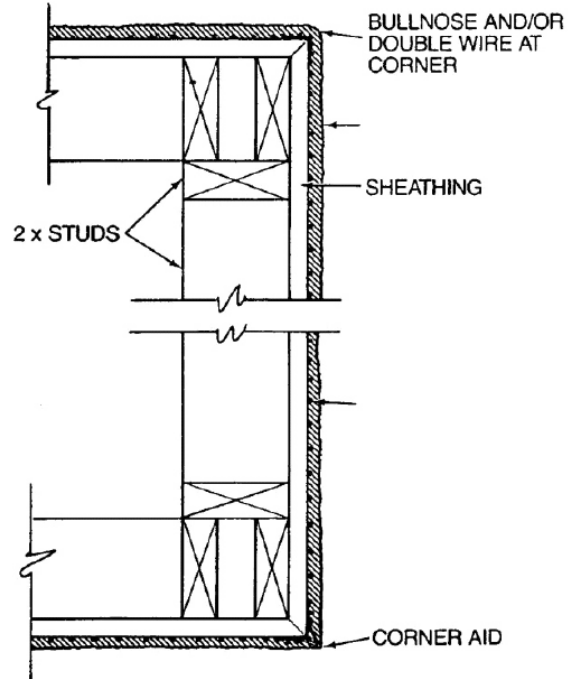

SQUARE CORNER-BULLNOSE CORNER

FIGURE 1

NOTE: PARAPET CAP SHOULD BE BULLNOSED OR SLOPED. FOAM SHEATHING ON TOP AND ROOFSIDE OF PARAPET OPTIONAL. WHEN FOAM IS OMITTED USE APPROVED SOLID BACKING.

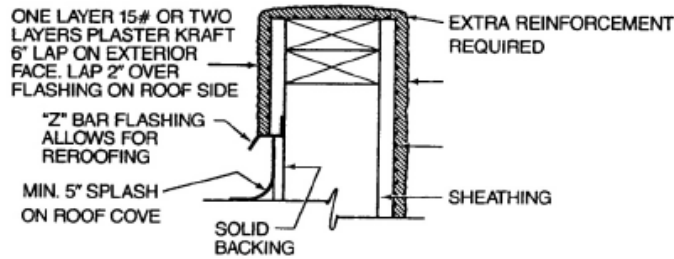

PARAPET AND FLASHING DETAIL

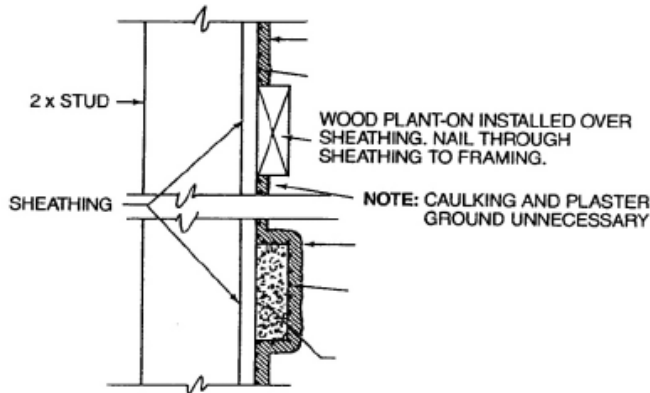

PLANT-ON

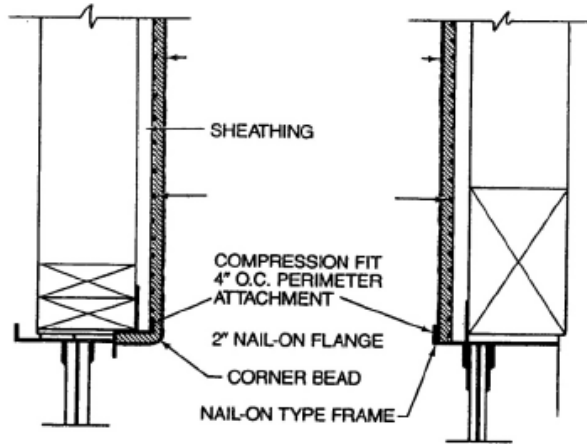

SLIDING DOOR

For SI: 1 inch = 25.4 mm.

FIGURE 1 (Continued)

INSTALLATION CARD
RAPID SET ONE COAT STUCCO SYSTEM
CTS CEMENT MANUFACTURING COMPANY

Job Address

ICC Evaluation Service, Inc.

ESR-2671

Date of Job Completion: _____

Plastering Contractor

Name: _____

Address: _____

Telephone No. () _____

Approved contractor number as issued
by the coating manufacturer _____

This is to certify that the exterior coating system on the building exterior at the above address has been installed in accordance with the evaluation report specified above and the manufacturer's instructions.

Signature of authorized representative
of plastering contractor

Date

This installation card must be presented to the building inspector after completion of work and before final inspection.

FIGURE 2

DIVISION: 09 00 00—FINISHES

Section: 09 24 00—Portland Cement Plastering

REPORT HOLDER:

CTS CEMENT MANUFACTURING CORPORATION

EVALUATION SUBJECT:

RAPID SET ONE COAT STUCCO SYSTEM

1.0 REPORT PURPOSE AND SCOPE

Purpose:

The purpose of this evaluation report supplement is to indicate that the Rapid Set One Coat Stucco System, described in ICC-ES evaluation report ESR-2671, has also been evaluated for compliance with the codes noted below.

Applicable code edition(s):

- 2019 *California Building Code* (CBC)

For evaluation of applicable chapters adopted by the California Office of Statewide Health Planning and Development (OSHPD) AKA: California Department of Health Care Access and Information (HCAI) and the Division of State Architect (DSA), see Sections 2.1.1 and 2.1.2 below.

- 2019 *California Residential Code* (CRC)

2.0 CONCLUSIONS

2.1 CBC:

The Rapid Set One Coat Stucco System, described in Sections 2.0 through 7.0 of the evaluation report ESR-2671, complies with CBC Chapters 25, provided the design and installation are in accordance with the 2018 *International Building Code*® (IBC) provisions noted in the evaluation report and the additional requirements of CBC Chapters 23 and 25, as applicable.

2.1.1 OSHPD:

The applicable OSHPD Sections of the CBC are beyond the scope of this supplement.

2.1.2 DSA:

The applicable DSA Sections of the CBC are beyond the scope of this supplement.

2.2 CRC:

The Rapid Set One Coat Stucco System, described in Sections 2.0 through 7.0 of the evaluation report ESR-2671, complies with CRC Chapters 3 and 7, provided the design and installation are in accordance with the 2018 *International Residential Code*® (IRC) provisions noted in the evaluation report and the additional requirements of CRC Chapters 3 and 7.

This supplement expires concurrently with the evaluation report, reissued February 2025.