

ICC-ES Evaluation Report

ESR-2764

Reissued March 2025

Revises April 2025

Subject to renewal March 2026



This report also contains:

- [City of LA Supplement](#)



ICC-ES Evaluation Reports are not to be construed as representing aesthetics or any other attributes not specifically addressed, nor are they to be construed as an endorsement of the subject of the report or a recommendation for its use. There is no warranty by ICC Evaluation Service, LLC, express or implied, as to any finding or other matter in this report, or as to any product covered by the report.

Copyright © 2025 ICC Evaluation Service, LLC. All rights reserved.

<p>DIVISION: 03 00 00— CONCRETE</p> <p>Section: 03 21 00— Reinforcement Bars</p>	<p>REPORT HOLDER:</p> <p>HEADED REINFORCEMENT CORP.</p>  <p>HEADED REINFORCEMENT CORP.</p>	<p>EVALUATION SUBJECT:</p> <p>HRC 500/510 XTENDER® AND HRC 300 SERIES FORM PROTECTOR MECHANICAL COUPLER SYSTEMS</p>	
--	---	---	---

1.0 EVALUATION SCOPE

Compliance with the following codes:

- 2024, 2021, 2018, 2015, 2012 and 2009 [International Building Code® \(IBC\)](#)

Property evaluated:

- Structural

2.0 USES

The HRC 500/510 Xtender® Mechanical Coupler system is used for tension and compression mechanical splices of uncoated, deformed steel reinforcing bars used in the design and construction of structural concrete members.

The HRC 300 Series Form Protector system is used for tension and compression mechanical splices of uncoated, deformed steel reinforcing bars used in the design and construction of structural concrete members. It provides steel reinforcing bar continuity without damaging formwork and reduces transition zone interference when adding headed, hooked or straight dowel steel reinforcing bars post pour.

The splices comply with Section 25.5.7.1 of ACI 318-19 for the 2024 and 2021 IBC, ACI 318-14 for the 2018 and 2015 IBC, and Section 12.14.3.2 of ACI 318 (-11 and -08) for the 2012 and 2009 IBC, respectively, as ACI 318 is referenced in IBC Section 1901.2. The mechanical splices are for use as either Type 1 or Type 2 mechanical splices of deformed steel reinforcing bars in accordance with Section 18.2.7.1 of ACI 318-19 for the 2024 and 2021 IBC, ACI 318-14 for the 2018 and 2015 IBC, and Section 21.1.6.1 of ACI 318 (-11 and -08) for the 2012 and 2009 IBC, respectively.

3.0 DESCRIPTION

3.1 General:

The HRC 500/510 Xtender® Mechanical Coupler system consists of an HRC 500 threaded male coupler component, an HRC 510 threaded female coupler component and two steel reinforcing bars that are prepared with headed upset ends. Dimensions and a typical assembly are shown in [Table 1](#).

HRC 500/510 is a positional coupler, allowing pre-bent and pre-tied reinforcing bars to be installed without rotating the reinforcing steel. The coupler is used to mechanically butt-splice No. 4 through No. 11 and No. 14 steel reinforcing bars.

The HRC 300 Series Form Protector system consists of an HRC 300 threaded female coupler component and two steel reinforcing bars that are prepared with HRC 300 threaded ends. Dimensions and a typical assembly are shown in [Figure 4](#) and [Table 2](#). The coupler is used to mechanically splice No. 4 through No. 8 steel reinforcing bars. An optional non-structural form mounting flange may also be attached at the end of the coupler.

3.2 Material:

3.2.1 HRC 500/510 Couplers: The couplers are manufactured from steel complying with either Grade 1144 or 1141 of ASTM A311-04, or ASTM A576-90b (reapproved 2006).

3.2.1.1 Steel Reinforcing Bars: The deformed steel reinforcing bars used with the couplers must comply with one of the following:

Reinforcing Size	Reinforcing Grade
#4 through #11 and #14	ASTM A706 Grade 60 ASTM A615 Grade 60
#8, #11 and #14	ASTM A615 Grade 75
#8 through #11 and #14	ASTM A706 Grade 80 ASTM A615 Grade 80

The reinforcing bars must have headed ends complying with the specification provided by Headed Reinforcement Corporation (HRC).

3.2.2 HRC 300 Couplers: The couplers are manufactured from steel complying with ASTM A108 Grades 1018, 1144 and 1215.

3.2.2.1 Steel Reinforcing Bars: The deformed steel reinforcing bars used with the couplers must comply with one of the following:

Reinforcing Size	Reinforcing Grade
#4 through #8	ASTM A706 Grade 60 ASTM A615 Grade 60

The reinforcing bars must have threaded ends complying with the specification provided by Headed Reinforcement Corporation (HRC).

4.0 DESIGN AND INSTALLATION

4.1 General:

The HRC 500/510 Xtender[®] and HRC 300 Series Form Protector Mechanical Coupler systems must be installed in accordance with the applicable code and this evaluation report. The splice locations must be detailed on the plans approved by the code official. All required spacing and coverage described in Sections 7.7.2.3, 8.7.2.2, 11.7.2, 20.6.1, 25.2, 25.5, 25.6 of ACI 318 (-19 or -14), or Sections 7.6 and 7.7 of ACI 318 (-11 or -08), as applicable, must be measured from the outside of the coupler. As Type 2 splices, the couplers are permitted in any location within a member for all seismic design categories unless otherwise specified by ACI 318.

4.2 Installation:

4.2.1 HRC 500/510 Xtender[®] Shop Preassembled Coupler and Steel Reinforcing Bars: Where the threaded male and female couplers are preassembled onto headed steel reinforcing bars by HRC-approved fabricators, excessive rust and adhered concrete must be removed from the coupler threads, if necessary, with a wire brush and lubricant prior to field assembly of the couplers. The male and female coupler components are screwed together hand-tight without the need to rotate the bars themselves. (See [Figure 1](#).) The assembly must be hand-tightened to a snug fit. Lubricate threads and use wrenches if necessary. Visual inspection must be performed according to [Figure 2](#). Full threads must not be visible. The male collar and female sleeve must not touch or bottom out.

4.2.2 HRC 500/510 Extender[®] Jobsite Assembled Coupler and Steel Reinforcing Bars: Where the couplers are installed onto the ends of the steel reinforcing bars at the jobsite, the installation process must be as described in the steps below.

Step 1: The Xtender[®] splicing system must have a minimum length of straight reinforcement bar equal to approximately six times the diameter of the bar being spliced, but not less than 6 inches (152 mm), to accommodate the Xtender[®] upsetting equipment.

Step 2: The threaded male nut must be inserted over the reinforcing bar with head seat towards the end of the bar. The end of the reinforcing bar must be heated over a length equal to approximately two bar diameters and to a temperature between 1800°F (982°C) and 2250°F (1232°C). Heating should be carried out such that the end of the reinforcing bar is evenly heated.

Step 3: The Xtender® upsetting machine must be inserted over the heated end of the reinforcing bar and a hydraulic pressure of 8,000 to 10,000 psi (55.2 MPa to 69 MPa) applied to the upsetting equipment. The bar must be air-cooled after the upsetting equipment is removed from the bar.

Step 4: Steps 1 through 3 must be repeated using the other reinforcing bar and the female coupler, unless the bar and coupler have been preassembled offsite.

Step 5: Utilizing the right-handed threads, the two components are hand-tightened together as described in Section 4.2.1.

4.2.3 HRC 300 Installation: The HRC 300 Series Form Protector system installation process must be as described in the steps below.

Step 1: All steel threaded reinforcing bars for use with the HRC 300 Series Form Protector system must be threaded by HRC.

Step 2: The HRC 300 threaded female coupler is threaded onto one of the male threaded steel reinforcing bars to create an assembly that is shipped to the jobsite. The male threaded steel reinforcing bar and female coupler component are screwed together and hand-tightened to a snug fit. Lubricate the threads and use wrenches if necessary. Visual inspection must be performed ensuring that full threads on the steel reinforcing bar are not visible. At a minimum, the threaded steel reinforcing bar must engage into the coupler a distance equal to “T” provided in [Table 2](#). This process can also be done at the jobsite if the coupler and the corresponding threaded steel reinforcing bars are shipped unassembled. The remaining threaded steel reinforcing bars required for the system may be shipped at the same time or later depending on the jobsite requirements.

Step 3: The assembly must be installed at the jobsite in the correct location. The optional form mounting flange may be used to position the steel reinforcing bars in the formwork. Once the concrete pour is completed and the formwork is removed, the protective seal must be removed, and the remaining male threaded steel reinforcing bar is screwed into the exposed threaded female coupler and hand-tightened to a snug fit. Excessive rust and adhered concrete must be removed from the coupler threads, if necessary, with a wire brush and lubricant prior to threading the steel reinforcing bar in. Lubricate the threads and use wrenches if necessary. Visual inspection must be performed ensuring full threads on the steel reinforcing bar are not visible. At a minimum, the steel threaded bar must engage into the coupler a distance equal to “T” provided in [Table 2](#).

4.3 Special Inspection:

Special inspection must be provided at the jobsite as required by Section 1705 of the 2025, 2021, 2018, 2015 and 2012 IBC, and Section 1704 of the 2009 IBC, as applicable. The inspector’s duties include verifying grade and size of reinforcing bar, coupler identification, heading of reinforcing bar (if applicable), field preparation of components (including field preparation of reinforcing bar ends), position of coupler, and placement of reinforcing bar splices, as well as assembly of the coupler component.

5.0 CONDITIONS OF USE:

The HRC 500/510 Xtender® and HRC 300 Series Form Protector Mechanical Coupler systems described in this report comply with, or are suitable alternatives to what is specified in, the code indicated in Section 1.0 of this report, subject to the following conditions:

- 5.1** The HRC 500/510 and HRC 300 couplers must be installed in accordance with the code, the manufacturer’s instructions, and this report. In the case of conflict between the manufacturer’s published instructions and this report, this report governs.
- 5.2** Splice locations must comply with applicable IBC requirements and be noted on plans approved by the code official.
- 5.3** Under the 2024 and 2021, for structures regulated by Chapter 18 of ACI 318-19 (as required by 2024 and 2021 IBC Section 1905.1), to splice deformed longitudinal reinforcing bars resisting earthquake-induced moment, axial force, or both, in special moment frames, special structural walls, and all components of special structural walls including coupling beams and wall piers, with the mechanical splice systems, mill certificates of reinforcing bars must be submitted to the code official as evidence that the steel reinforcing bars comply with ACI 318-19 Section 20.2.2.5.

- 5.4 Under the 2018 and 2015 IBC, for structures regulated by Chapter 18 of ACI 318-14 (as required by 2018 and 2015 IBC Section 1905.1), to splice deformed longitudinal reinforcing bars resisting earthquake-induced moment, axial force, or both, in special moment frames, special structural walls, and all components of special structural walls including coupling beams and wall piers, with the mechanical splice systems, mill certificates of reinforcing bars must be submitted to the code official as evidence that the steel reinforcing bars comply with ACI 318-14 Section 20.2.2.5.
- 5.5 Under the 2012 IBC, for structures regulated by Chapter 21 of ACI 318-11 (as required by the 2012 IBC Section 1905.1), to splice uncoated, deformed reinforcing bars resisting earthquake-induced flexure, axial force, or both, in special moment frames, special structural walls, and all components of special structural walls including coupling beams and wall piers, the couplers are limited to use with ASTM A706 Grade 60 or ASTM A615 Grade 60 steel reinforcing bars and mill certificates of reinforcing bars must be submitted to the code official as evidence that the steel reinforcing bars comply with ACI 318-11 Section 21.1.5.2.
- 5.6 Under the 2009 IBC, for structures regulated by Chapter 21 of ACI 318-08 (as required by 2009 IBC Section 1908.1), to splice uncoated, deformed reinforcing bars resisting earthquake-induced flexural and axial forces in frame members, structural walls and coupler beams, the couplers are limited to use with ASTM A706 Grade 60 or ASTM A615 Grade 60 steel reinforcing bars and mill certificates of reinforcing bars must be submitted to the code official as evidence that the steel reinforcing bars comply with ACI 318-08 Section 21.1.5.2.
- 5.7 Special inspections must be provided in accordance with Section 4.3 of this report.
- 5.8 Minimum concrete cover must be in accordance with the applicable code and must be measured from the outer surface of the coupler.
- 5.9 When HRC 500/510 couplers are preassembled onto the headed ends of the reinforcing bars at a fabricator's facility, the fabricator must be approved by the report holder, HRC.
- 5.10 When HRC 500/510 couplers are jobsite-assembled onto the steel reinforcing bars that are prepared (headed) at the jobsite, the jobsite fabricator must be approved by the report holder, HRC.
- 5.11 The evaluation of corrosion resistance of the mechanical splice is outside the scope of this evaluation and shall be considered by the registered design professional during the design.
- 5.12 The headed reinforcing bars for the HRC 500/510 couplers that are headed by Headed Reinforcement Corporation are formed/headed in Fountain Valley, California under a quality-control program with inspections by ICC-ES. All other heading operations must comply with Sections 5.7 and 5.8, above.
- 5.13 The threaded steel reinforcing bars for use with the HRC 300 couplers are threaded by Headed Reinforcement Corporation in Fountain Valley, California under a quality control program with inspections by ICC-ES.

6.0 EVIDENCE SUBMITTED

Data in accordance with the [ICC-ES Acceptance Criteria for Mechanical Splice Systems for Steel Reinforcing Bars AC133\(24\) 2nd Edition](#), published April 2025.

7.0 IDENTIFICATION

7.1 HRC 500/510 Couplers Shipped to Fabricator or Jobsite:

Each coupler is stamped or labeled with the product designation of "HRC 510" (female) or "HRC 500" (male), the bar size, lot number and "T2" to designate the use of the coupler as a Type 2 Splice. The packaging for the coupler is labeled with this same information and the Xtender® logo and the ICC-ES evaluation report number (ESR-2764).

7.2 Couplers Shipped to Jobsite Already Attached to Reinforcing Bars:

7.2.1 Couplers Attached to Reinforcing Bars by HRC: Each coupler attached to a reinforcing bar at the HRC facility must be labeled as indicated in Section 7.1 and be accompanied to the jobsite with tags or labels bearing the HRC company name and the ICC-ES evaluation report number (ESR-2764) and paperwork indicating the couplers and bars were assembled by HRC.

7.2.2 Couplers Attached to Reinforcing Bars by Approved Fabricators: Couplers attached to reinforcing bars by a fabricator approved by the code official must be labeled as indicated in Section 7.1 and be accompanied to the jobsite with tags or labels and paperwork, as required by the code official indicating the couplers and bars were assembled by the fabricator approved by the code official.

7.2.3 HRC 300 Couplers: Each coupler is stamped or labeled with the product designation “HRC 300”, the steel reinforcing bar size, lot number and “T2” to designate the use of the coupler as a Type 2 mechanical splice system.

7.3 The report holder’s contact information is the following:

HEADED REINFORCEMENT CORPORATION
11200 CONDOR AVENUE
FOUNTAIN VALLEY, CALIFORNIA 92708
(714) 557-1455
www.hrc-usa.com
engineering@hrc-usa.com

TABLE 1—DIMENSIONS OF HRC 500/510 COUPLERS

Bar size	#4	#5	#6	#7	#8	#9	#10	#11	#14
A - Coupler OD [in]	1.375	1.500	1.625	1.875	2.125	2.375	2.625	2.875	3.500
B -Typical Length [in]	2.00	2.13	2.38	2.88	3.13	3.50	3.75	4.25	5.13

For SI: 1 inch = 25.4 mm, 1 in² = 645 mm².

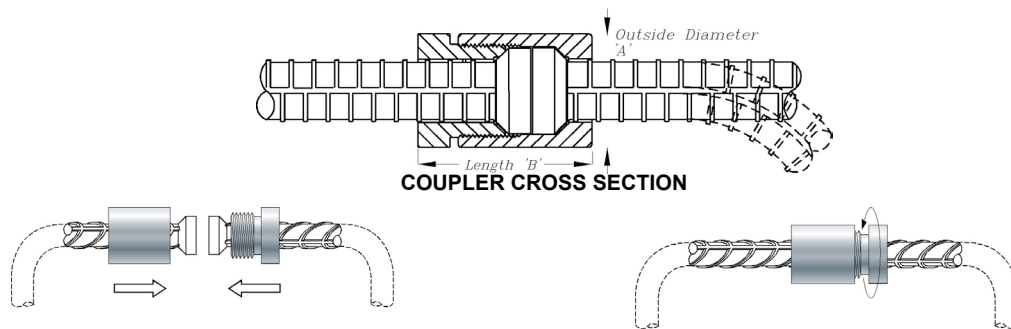

FIGURE 1—500/510 SERIES COUPLERS

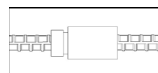

FIGURE 2—500/510 VISUAL INSPECTION



FIGURE 3—XTENDER LOGO

TABLE 2—DIMENSIONS OF HRC 300 COUPLERS ^{1,2}

REBAR PROPERTIES			THREAD / COUPLER DIMENSIONS			
BAR SIZE	DIAMETER (INCH)	AREA (IN ²)	THREAD INFORMATION		LENGTH L (INCH)	DIAMETER D (INCH)
			THREAD SIZE UNC	T (INCH)		
#4	0.500	0.20	1/2"-13 UNC	0.75	1.75	0.88
#5	0.625	0.31	5/8"-11 UNC	0.75	2.00	1.00
#6	0.750	0.44	3/4"-10 UNC	1.00	2.13	1.13
#7	0.875	0.60	7/8"-9 UNC	1.00	2.50	1.25
#8	1.000	0.79	1"-8 UNC	1.13	3.00	1.50

For SI: 1 inch = 25.4 mm, 1 in² = 645 mm²

¹HRC 300 Form Protector Couplers develop the minimum tensile strength of the spliced steel reinforcing bar (ASTM A706 / A615 Grade 60).

²Hand-tighten to a snug fit. Lubricate threads and use wrench if necessary.

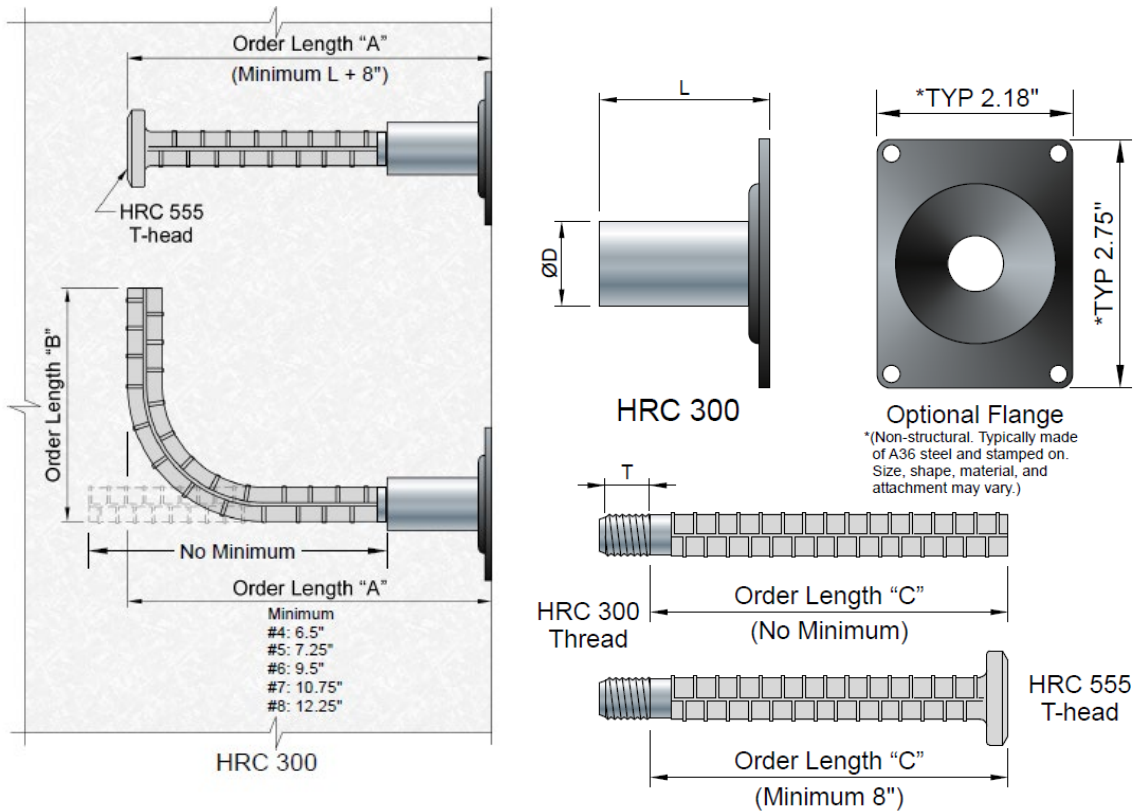

FIGURE 4—HRC 300 SERIES FORM PROTECTOR

DIVISION: 03 00 00—CONCRETE

Section: 03 21 00—Reinforcement Bars

REPORT HOLDER:

HEADED REINFORCEMENT CORP.

EVALUATION SUBJECT:

HRC 500/510 XTENDER® AND HRC 300 SERIES FORM PROTECTOR MECHANICAL COUPLER SYSTEMS

1.0 REPORT PURPOSE AND SCOPE

Purpose:

The purpose of this evaluation report supplement is to indicate that the HRC 500/510 Xtender® Mechanical Coupler system, described in ICC-ES evaluation report [ESR-2764](#), has also been evaluated for compliance with the code noted below as adopted by the Los Angeles Department of Building and Safety (LADBS).

Applicable code edition:

2023 City of Los Angeles Building Code ([LABC](#))

2.0 CONCLUSIONS

The HRC 500/510 Xtender® Mechanical Coupler system, described in Sections 2.0 through 7.0 of the evaluation report [ESR-2764](#), complies with the LABC Chapter 19, and is subject to the conditions of use described in this supplement.

3.0 CONDITIONS OF USE

The HRC 500/510 Xtender® Mechanical Coupler system described in this evaluation report supplement must comply with all of the following conditions:

- All applicable sections in the evaluation report [ESR-2764](#).
- The design, installation, conditions of use and identification of the HRC 500/510 Xtender® Mechanical Coupler system are in accordance with the 2021 *International Building Code*® (IBC) provisions noted in the evaluation report [ESR-2764](#).
- The design, installation and inspection are in accordance with additional requirements of LABC Chapters 16, 17 and 19, as applicable.
- Continuous special inspection by Deputy Inspectors shall be provided during installation of splices.
- The mechanical coupler system assembly shall be produced in the shop of an approved City of Los Angeles fabricator, in accordance with LABC Section 202 definition for "Fabricated Item" and LABC Section 96.203.

This supplement expires concurrently with the evaluation report, reissued March 2025, revised April 2025.