

ICC-ES Evaluation Report

ESR-2771

Reissued February 2025

Subject to renewal January 2026

ICC-ES Evaluation Reports are not to be construed as representing aesthetics or any other attributes not specifically addressed, nor are they to be construed as an endorsement of the subject of the report or a recommendation for its use. There is no warranty by ICC Evaluation Service, LLC, express or implied, as to any finding or other matter in this report, or as to any product covered by the report.

Copyright © 2025 ICC Evaluation Service, LLC. All rights reserved.

<p>DIVISION: 07 00 00 — THERMAL AND MOISTURE PROTECTION</p> <p>Section: 07 24 00 — Exterior Insulation and Finish Systems</p> <p>Section: 07 24 19 — Water-Drainage Exterior Insulation and Finish System</p>	<p>REPORT HOLDER:</p> <p>TOTAL WALL, INC.</p>	<p>EVALUATION SUBJECT:</p> <p>HARDCOAT PM, MOISTURE DRAINAGE MD AND SOFTCOAT PB EXTERIOR INSULATION AND FINISH SYSTEMS</p>	
------------------------------------------------------------------------------------------------------------------------------------------------------------------------------------------------------------------------------------	-------------------------------------------------------------	------------------------------------------------------------------------------------------------------------------------------------------	-------------------------------------------------------------------------------------

1.0 EVALUATION SCOPE

Compliance with the following codes:

- 2006 [International Building Code® \(IBC\)](#)
- 2006 [International Residential Code® \(IRC\)](#)
- 1997 [Uniform Building Code™ \(UBC\)](#)

Properties evaluated:

- Weather resistance
- Wind load resistance
- Surface-burning characteristics
- Noncombustible construction

2.0 USES

The HardCoat PM, Moisture Drainage MD and SoftCoat PB systems are wall coverings applied to exterior, framed walls of combustible construction. The SoftCoat PB system may also be applied to walls of noncombustible construction as described in Section 4.3.3 of this report. The HardCoat PM and SoftCoat PB systems are not evaluated for use on framed walls of Type V, Group R1, R2, R3 and R4, Occupancies under the IBC; on framed walls constructed under the IRC; or on framed walls of Type V, Group R, Division 1 or Division 3, Occupancies under the UBC.

3.0 DESCRIPTION

3.1 HardCoat PM System:

3.1.1 General: The HardCoat PM system is a six-component system in which the foam plastic insulation is mechanically fastened over 1/2-inch-thick (12.7 mm), water-resistant core gypsum sheathing to wood studs. The system components are a water-resistive barrier, optional plastic lath, rigid extruded polystyrene (XEPS) insulation boards, open-weave glass-fiber reinforcing fabric, a base coat, and a finish coat.

3.1.2 Materials:

3.1.2.1 Gypsum Sheathing: The gypsum sheathing must have a water-resistant core and must comply with ASTM C79 or ASTM C1396.

3.1.2.2 Water-resistive Barrier: The barrier, when used, must be one of the materials described in IBC Section 1404.2, IRC Section R703.2, or UBC Section 1402.1, as applicable.

3.1.2.3 Plastic Lath: Ultra-Lath PVC plastic lath measures 27 inches by 96 inches by $\frac{1}{4}$ inch thick (686 mm by 2438 mm by 6.4 mm). It weighs 0.139 psf (0.68 kg/m²) and is manufactured by Plastic Components, Inc.

3.1.2.4 Insulation Board: Insulation for the HardCoat PM system is rigid XEPS board identified as Dow STYROFOAM brand Square Edge or Dow STYROFOAM brand Tongue-and-Groove. The board has minimum and maximum thicknesses of 1 inch (25.4 mm) and $1\frac{1}{2}$ inches (38 mm), respectively; a flame-spread rating of less than 25; a smoke-developed rating of less than 450; and a nominal density of 2.0 pcf (32 kg/m³).

3.1.2.5 Reinforcing Fabric: The reinforcing fabric is 4.5-ounce-per-square-yard (153 g/m²), $\frac{3}{8}$ -inch (9.5 mm) open weave, fiberglass mesh treated for alkali resistance. Rolls are 38 inches (965 mm) wide by 150 feet (45 720 mm) long.

3.1.2.6 Base Coat: HardCoat Basecoat is a field-blended mixture of 5 gallons (18.9 L) of Liquid Acrylic Additive, 94 pounds (42.6 kg) of portland cement, 150 pounds (68 kg) of graded sand and 1 pound (0.454 kg) of Total Wall Fibers. The cement is Type I, II or I-II portland cement complying with UBC Standard 19-1. The sand is dry, iron-free, quartz sand, 45-55 mesh.

Liquid Acrylic Additive is a 100 percent acrylic, water-based emulsion, and has a shelf life of 18 to 24 months when stored in unopened containers at temperatures between 50°F and 100°F (10°C and 38°C). The fibers are chopped-strand, $\frac{1}{2}$ -inch-long (12.7 mm) fiberglass fibers provided in preweighed bags.

3.1.2.7 Finish Coat: The Acrylic Finish finish coats for the HardCoat PM system are ready-to-use, 100 percent acrylic-based, integrally colored synthetic coatings, available in various colors and textures. Shelf life is 12 to 18 months when stored in unopened containers at temperatures between 50°F and 100°F (10°C and 38°C).

3.1.2.8 Sealants: The sealants must be compatible with the EIFS components and be recommended by Total Wall, Inc. Evidence must be submitted to the building official showing that the EIFS manufacturer-recommended sealant is a Type S or M, minimum Grade NS, minimum Class 25, and Use O sealant complying with ASTM C 920. Under the Type O classification, the sealant must be qualified for each material to which the sealant will be applied. The details for sealant installation, including the width and thickness of the sealant, must be designed by the registered design professional, designer, builder or Total Wall, Inc., in that order, to the satisfaction of the building official. Backer rods must be closed-cell polyethylene.

3.1.2.9 Trim: Trim accessories such as stops, corner beads and weep bases are available.

3.2 Moisture Drainage MD System:

3.2.1 General: The Moisture Drainage MD system is a five-component system in which the foam plastic insulation is mechanically attached to plywood substrates attached to wood studs. The system components are a weather-resistive barrier, rigid expanded polystyrene (EPS) insulation boards, open-weave glass-fiber reinforcing fabric, a base coat, and a finish coat.

3.2.2 Materials:

3.2.2.1 Plywood Sheathing: Minimum $\frac{5}{8}$ -inch-thick (15.1 mm), exterior grade or Exposure 1 plywood sheathing complying with U.S. DOC PS-1 (UBC Standard 23-2).

3.2.2.2 Water-resistive Barrier: The barrier must be a minimum of two layers of Grade D kraft building paper as set forth in IBC Section 2510.6 or UBC Section 2506.4; or one layer of Grade D kraft building paper having a minimum water-resistance rating of 60 minutes; or Tyvek StuccoWrap[®].

3.2.2.3 Insulation: Insulation for the Moisture Drainage MD system is minimum 2-inch-thick (51 mm) rigid EPS complying with ASTM C 578, Type I and ASTM E2430, and must have a flame-spread rating of less than 25, a smoke-developed rating of less than 450, and a nominal density of 1.0 pcf (16 kg/m³). The EPS insulation must be evaluated in a current ICC-ES evaluation report complying with the ICC-ES Acceptance Criteria for Foam Plastic Insulation (AC12). When the water-resistive barrier is building paper, the EPS insulation must incorporate 0.25-inch-deep (6.35 mm), 0.5542-inch-wide (14.07 mm) grooves spaced at approximately 1.4 inches (35.6 mm) on center across the width of the board. The grooved foam plastic board is illustrated in [Figure 3](#).

3.2.2.4 Weep Screed: The weep screed is PVC track having $\frac{1}{4}$ -inch-diameter (6.4 mm) weep holes spaced 3 inches (76 mm) on center, a 1-inch-high (12.7 mm) drip edge, and a $2\frac{3}{4}$ -inch-high (70 mm) back flange with a 110-degree angle. The track is supplied by Windlock Corporation in 8-foot (2438 mm) lengths and varying thicknesses to accommodate different foam board thicknesses.

3.2.2.5 Reinforcing Fabric: The reinforcing fabric is a 4.5-ounce-per-square-yard (153 g/m²), $\frac{1}{4}$ -inch (6.4 mm) open weave, fiberglass mesh treated for alkali resistance. Rolls are 38 inches (965 mm) wide by 150 feet (45 720 mm) long.

3.2.2.6 Base Coat: SoftCoat Basecoat is field-mixed with Type I, II or I-II portland cement complying with ASTM C 150 in a one-to-one ratio by weight. Up to 2 pounds (0.90 kg) of water may be added for each 60 pounds (27 kg) of mixture. Shelf life is 12 to 18 months when the base coat is stored in unopened containers at temperatures between 50°F and 100°F (10°C and 38°C).

3.2.2.7 Finish Coat: The Acrylic Finish finish coats for the Moisture Drainage MD system are ready-to-use, 100 percent acrylic-based, integrally colored synthetic coatings, available in various colors and textures. Shelf life is 12 to 18 months when the finish coat is stored in unopened containers at temperatures between 50°F and 100°F (10°C and 38°C).

3.2.2.8 Sealants: Sealants are described in Section 3.1.2.8.

3.2.2.9 Trim: Trim accessories such as stops and corner beads are available.

3.3 SoftCoat PB System:

3.3.1 General: The SoftCoat PB system is a five-component system in which the foam plastic insulation is adhesively attached to $\frac{1}{2}$ -inch-thick (12.7 mm), core-treated water-resistant gypsum sheathing over wood or steel studs. The five components are adhesive, rigid EPS insulation boards, open-weave glass-fiber reinforcing fabric, base coat, and finish coat.

3.3.2 Materials:

3.3.2.1 Insulation Board: Insulation for the adhesively attached SoftCoat PB system must be rigid EPS complying with ASTM C 578, Type I, with a minimum thickness of 1 inch (25.4 mm), a flame-spread rating of 25 or less, a smoke-developed rating of 450 or less and a nominal density of 1.0 pcf (16 kg/m³). The EPS insulation must be evaluated in a current ICC-ES evaluation report and must be manufactured specifically for use with EIFS.

3.3.2.2 Adhesive:

3.3.2.2.1 Blue Mastic Adhesive: Blue Mastic Adhesive is a ready-to-use, high-solids, 100 percent acrylic compound. Two ounces (59.1 mL) of clean water may be added for workability. The adhesive is used to adhere insulation boards to gypsum sheathing on steel studs. The shelf life is 18 months when the adhesive is stored in unopened containers at temperatures between 50°F (10°C) and 100°F (37.7°C).

3.3.2.2.2 SoftCoat Basecoat: SoftCoat Basecoat is a 100 percent acrylic emulsion that is field-mixed with Type I, II or I-II portland cement in a one-to-one ratio by weight. Portland cement must comply with ASTM C 150. The mixture is used as an adhesive to adhere insulation boards to gypsum sheathing on wood studs. The shelf life of SoftCoat Basecoat is 12 to 18 months when it is stored in unopened containers at temperatures between 50°F and 100°F (10°C and 38°C).

3.3.2.3 Base Coat:

3.3.2.3.1 T-2000 DRYBASE: T-2000 DRYBASE is a dry powder mixed with water at the jobsite. One 50-pound (22.7 kg) bag of T-2000 DRYBASE is mixed with between 4 and 5.5 quarts (3.8 and 5.2 L) of water. The mixture is used as the base coat of systems applied over gypsum sheathing attached to steel studs.

3.3.2.3.2 SoftCoat Basecoat: SoftCoat Basecoat is a 100 percent emulsion that is field-mixed with Type I, II or I-II portland cement in a one-to-one ratio by weight. Portland cement must comply with ASTM C150. The mixture is used as the base coat of systems applied over gypsum sheathing attached to wood studs. The shelf life is 12 to 18 months when stored in unopened containers at temperatures between 50°F and 100°F (10°C and 38°C).

3.3.2.4 Reinforcing Fabric: The reinforcing fabric is a 4.5-ounce-per-square-yard (153 g/m²), $\frac{1}{4}$ -inch (6.4 mm) open weave, fiberglass mesh treated for alkali resistance. Rolls are 38 inches (965 mm) wide by 150 feet (45 720 mm) long.

3.3.2.5 Finish Coat: The Acrylic Finish finish coats for the SoftCoat PB system are ready-to-use, 100 percent acrylic-based, integrally colored synthetic coatings, available in various colors and textures. Shelf life is 12 to 18 months when the finish coat is stored in unopened containers at temperatures between 50°F and 100°F (10°C and 38°C).

3.3.2.6 Gypsum Sheathing: Core-treated water-resistant gypsum sheathing must comply with ASTM C 79 or ASTM C 1396.

3.3.2.7 Sealants: Sealants are as described in Section 3.1.2.8.

4.0 INSTALLATION

4.1 HardCoat PM System:

4.1.1 General: Planar irregularities in substrates must be limited to 1/4 inch (6.4 mm) in a 4-foot (1219 mm) radius. Vertical joints of insulation board must be staggered from edges of wall openings. All penetrations must be completed by back-wrapping the board edges. Coatings must be applied at temperatures above 40°F (4.4°C), and the substrate must be protected from precipitation for 24 hours prior to application. The substrate must be structurally sound, clean, and dry. Control joints are required at each floor level.

Wood framing must comply with the applicable building code and be minimum 2-by-4 wood studs spaced a maximum of 16 inches (406 mm) on center. The framing members must be designed to resist all positive and negative transverse loads with a maximum allowable deflection of L/240.

Gypsum sheathing is attached vertically to wood studs with 1 1/2-inch-long (38 mm), No. 6, Type W screws, spaced 8 inches (203 mm) on center. Vertical board edges must butt over studs. One layer of Grade D building paper is attached in accordance with IBC Section 1404.2, IRC Section R703.2, or UBC Section 1402.1, as applicable. Optional plastic lath is then temporarily attached over the building paper with 1/2-inch-long (12.7 mm) staples. The extruded polystyrene foam plastic boards and reinforcing fabric are mechanically attached through the lath and sheathing to the framing with 3-inch-long (76 mm), Type W, Wind-lock, corrosion-resistant No. 8 screws and minimum 1 3/4-inch-diameter (44.5 mm) Wind-lock ULP 302 plates, spaced 12 inches (305 mm) vertically and 16 inches (406 mm) horizontally. Fasteners must penetrate framing at least 1 1/8 inches (28.6 mm).

Reinforcing fabric must be continuous at all corners and lapped a minimum of 2 inches (51 mm) at fabric edges. HardCoat Basecoat is applied, by troweling or spraying, into the reinforcing fabric to a 3/16-inch (4.8 mm) to 1/4-inch (6.4 mm) thickness and must be allowed to dry a minimum of 12 hours prior to finish-coat application. Any irregularities in the base coat that are greater than 1/16 inch (1.6 mm) must be eliminated. The finish coat is then troweled or sprayed onto the base coat to a minimum thickness determined by the largest aggregate in the finish [approximately 1/16 inch (1.6 mm)]. See [Figure 1](#) for typical installation details.

Sealants must be applied at system terminations, exposed joints, floor lines, changes in building shape or roof line, substrate changes and expansion joints. Horizontal control joints are required at each floor level. Control joints must be installed as specified by the registered design professional, designer, builder, or exterior coating manufacturer, in that order.

4.1.2 Wind Design: When installed in accordance with this report, the HardCoat PM system is limited to a maximum design wind pressure of 33 psf (1580 Pa), positive or negative.

4.2 Moisture Drainage MD System:

4.2.1 General: Wood framing must comply with the applicable code and must be minimum 2-by-4 wood studs spaced a maximum of 16 inches (406 mm) on center. The framing members must be designed to resist all positive and negative transverse loads with a maximum allowable deflection of L/240.

Plywood sheathing is attached vertically to wood studs with 1 1/4-inch-long (31.7 mm), No. 6, bugle-head, galvanized drywall screws, spaced 8 inches (203 mm) on center. Vertical board edges must butt over studs. The water-resistive barrier is attached to the sheathing in accordance with IBC Section 1404.2, IRC Section R703.2, or UBC Section 1402.1, as applicable. Two layers of Grade D building paper, or one layer of Grade D building paper having a 60-minute water-resistance rating, or one layer of Tyvek StuccoWrap, are required over wood-based sheathing in accordance with IBC Section 2510.6, IRC Section R703.2, or UBC Section 2506.4. Optional plastic lath as described in Section 3.1.2.3 is temporarily attached with 1/2-inch-long (12.7 mm) staples. The EPS boards and reinforcing fabric are mechanically attached to the sheathing with 3-inch-long (76 mm), Type W, Wind-lock, No. 8, corrosion-resistant screws, and minimum 1 3/4-inch-diameter (44.5 mm) Wind Devil or Wind Devil 2 plates. Ten fasteners are used per 2-foot-by-4-foot (610 mm by 1219 mm) insulation board. When building paper is used as the water-resistive barrier, minimum 2 1/4-inch-thick (57.1 mm), grooved EPS foam boards must be used. The boards are installed with the grooves oriented vertically and are attached in the same manner as described above.

The weep screed is attached to framing with 1¹/₄-inch-long (31.7 mm) aluminum roofing nails, spaced at 6 inches (152 mm) on center.

Planar irregularities in substrates must be limited to 1/4 inch (6.4 mm) in a 4-foot (1219 mm) radius. Vertical joints of insulation board must be staggered from edges of wall openings. All penetrations must be completed by back-wrapping the board edges. Coatings must be applied at temperatures above 40°F (4.4°C), and the substrate must be protected from precipitation for 24 hours prior to application. The substrate must be structurally sound, clean, and dry.

Reinforcing fabric must be continuous at all corners and is lapped a minimum of 2¹/₂ inches (63.5 mm) at fabric edges. SoftCoat Basecoat is applied, by troweling or spraying, into the reinforcing fabric to a minimum 1/8-inch (3.2 mm) thickness and must be allowed to dry a minimum of 12 hours prior to finish-coat application. Any irregularities in the base coat that are greater than 1/16 inch (1.6 mm) must be eliminated. The finish coat is then troweled or sprayed onto the base coat to a minimum thickness determined by the largest aggregate in the finish [approximately 1/16 inch (1.6 mm)]. See [Figure 2](#) for typical installation details.

Sealants must be applied at system terminations, exposed joints, floor lines, changes in building shape or roof line, substrate changes and expansion joints. Horizontal control joints are required at each floor level. Control joints must be installed as specified by the architect, designer, builder, or exterior coating manufacturer, in that order.

4.2.2 Wind Design: When installed in accordance with this report, the Moisture Drainage MD system is limited to a maximum design wind pressure of 53 psf (2540 Pa), positive or negative.

4.3 SoftCoat PB System:

4.3.1 General: Gypsum sheathing must be installed vertically and attached with vertical board edges butting over studs. Planar irregularities are limited to 1/4 inch (6.4 mm) in a 4-foot (1219 mm) radius. Vertical joints of insulation board must be staggered from edges of wall openings. The coating must be applied at temperatures above 40°F (4.4°C), and the substrate must be protected from precipitation for 24 hours prior to application. Control joints are required at each floor level.

The substrate must be structurally sound, clean, dry, and free of all material that may reduce bonding of the adhesive. The EPS foam plastic board is adhesively attached to the sheathing with either Blue Mastic Adhesive, described in Section 3.3.2.2.1, using a stainless steel notched trowel having 1/2-inch-wide-by-3/8-inch-high (12.7 mm by 9.5 mm) U-shaped notches spaced at 2 inches (152 mm); or SoftCoat Basecoat, as described in Section 3.3.2.2.2, applied to the entire surface of the insulation board, using a 3/8-inch-by-1/2-inch-by-1 1/2-inch (9.5 by 12.7 by 38 mm) U-notched trowel. The board, applied in running bond, is slid into place on the sheathing, with pressure applied over the entire surface to ensure uniform contact. All joints are tightly butted, and any gaps greater than 1/16 inch (1.6 mm) must be filled with insulation.

The adhered insulation board must be left undisturbed a minimum of 12 hours prior to application of the base coat. The base coat is applied to the entire surface of the insulation board by troweling or spraying to a thickness of 1/8 inch (3.2 mm). The reinforcing fabric is fully embedded in the base coat and is troweled from the center to the edges. The fabric must be continuous at all corners and is lapped at least 2 inches (51 mm) at fabric edges. The base coat must be allowed to set a minimum of 18 hours before the application process continues. Any irregularities in the base coat greater than 1/16 inch (1.6 mm) must be eliminated. The finish coat is then applied by troweling or spraying to a thickness determined by the largest aggregate in the finish, approximately 1/16 inch (1.6 mm). See [Figure 4](#) for typical installation details.

4.3.2 Wood Framing: The SoftCoat PB system consisting of wood studs, gypsum sheathing, SoftCoat Basecoat as the adhesive and base coat, and Acrylic Finish as the finish coat, is limited to application on structures permitted to be of combustible, Type V construction, in other than Group R, Division 1, 2, 3 and 4, Occupancies under the IBC; and in other than Group R, Division 1 and Division 3, Occupancies under the UBC. The system is not evaluated for use with wood framing under the IRC. Wood studs must have a minimum specific gravity of 0.42 and be spaced a maximum of 16 inches (406 mm) on center. The gypsum sheathing is attached to the framing with 1 1/2-inch-long (38 mm), No. 6, Type W screws, spaced 8 inches (203 mm) on center.

4.3.3 Steel Framing: The SoftCoat PB system consisting of steel studs, gypsum sheathing, Blue Mastic Adhesive, T-2000 SoftCoat Base as the base coat and Acrylic Finish as the finish coat may be used in noncombustible, nonfire-resistive construction and on structures permitted to be of combustible, Type V construction, in other than (under the IBC) Group R, Division 1, 2, 3 and 4 Occupancies, and (under the UBC) Group R, Division 1 and Division 3, Occupancies. The system is not evaluated for use with steel framing under the IRC.

Steel studs must be minimum No. 18 gage [0.0486 inch (1.234 mm)], 3⁵/₈-inch-deep (92 mm) studs and must be spaced a maximum of 16 inches (406 mm) on center. Minimum 5/₈-inch-thick, Type X gypsum wallboard and minimum 5/₈-inch-thick (15.9 mm), Type X gypsum sheathing are attached to the framing on the interior and exterior, respectively, with No. 6, 1¹/₄-inch-long (31.7 mm), Type S screws spaced at 8 inches (203 mm) on center. Interior joints of the wallboard must be taped and treated with joint compound, and screw heads on the interior must be treated with joint compound. Openings must be framed with minimum No. 18 gage [0.0486 inch (1.234 mm)] steel framing. Maximum 4-inch-thick (102 mm) EPS insulation board, base coat and finish coat are applied as described in Section 4.3.1. Wall cavities and floor levels must be filled with noncombustible materials.

4.3.4 Wind Design: The SoftCoat PB system applied over wood or steel studs is limited to a maximum design wind pressure of 33 psf (1580 Pa), positive or negative.

4.4 Special Inspection:

In jurisdictions enforcing the IBC, special inspection in accordance with IBC Sections 1704.1 and 1704.12 is required for the HardCoat PM, SoftCoat PB exterior insulation and finish systems when installed over framed walls. Duties of the special inspector include verifying field preparation of materials, expiration dates, installation of components, and installation of joints and sealants.

5.0 CONDITIONS OF USE

The HardCoat PM, Moisture Drainage MD and SoftCoat PB exterior insulation and finish systems, as described in this report, comply with, or are suitable alternatives to what is specified in, those codes listed in Section 1.0 of this report, subject to the following conditions:

- 5.1 Installation must comply with this report, the manufacturer's published installation instructions and the applicable code. In the event of a conflict between the manufacturer's published instructions and this report, this report governs.
- 5.2 Insulation board must be separated from the building interior by a 15-minute thermal barrier complying with IBC Section 2603.4, IRC Section R314.1 or UBC Section 2602.4, as applicable.
- 5.3 The HardCoat PM and SoftCoat PB systems are not evaluated for use on framed walls of Type V, Group R, Division 1, 2, 3 and 4, Occupancies under the IBC; framed walls constructed under the IRC; or framed walls of Type V, Group R, Division 1 and 3, Occupancies under the UBC.
- 5.4 Use of the SoftCoat PB system in noncombustible construction must be as described in Section 4.3.3 of this report.
- 5.5 The design wind load pressures must not exceed the capacities indicated in Sections 4.1.2, 4.2.2 and 4.3.4 of this report, as applicable.
- 5.6 Under the UBC, the systems may be attached to the surface of an exterior, combustible, fire-resistive assembly without a change in the assigned hourly rating of the assembly.
- 5.7 In jurisdictions enforcing the IBC, special inspection must be provided as set forth in Section 4.4 of this report.
- 5.8 Installation is by applicators qualified by Total Wall, Inc.
- 5.9 Installation cards, such as those shown in [Figures 5](#) and [6](#), must be presented to the code official at the completion of each project.

6.0 EVIDENCE SUBMITTED

- 6.1 Data in accordance with the [ICC-ES Acceptance Criteria for Exterior Insulation and Finish Systems \(AC219\)](#), dated October 2003 (editorially revised April 2008).
- 6.2 Data in accordance with the [ICC-ES Acceptance Criteria for EIFS Clad Drainage Wall Assemblies \(AC235\)](#), dated October 2004 (editorially revised April 2008).

7.0 IDENTIFICATION

- 7.1 The ICC-ES mark of conformity, electronic labeling, or the evaluation report number (ICC-ES ESR-2771) along with the name, registered trademark, or registered logo of the report holder must be included in the product label.

7.2 In addition, system materials are identified by the Total Wall name and address; the product name; shelf life information, if applicable; and the evaluation report number (ESR-2771). Foam plastic insulation is identified in accordance with the applicable evaluation report. Wind-lock fasteners and plates are identified on the packaging by the Wind-lock name and the product name.

7.3 The report holder's contact information is the following:

TOTAL WALL, INC.
POST OFFICE BOX 8098
MADISON, WISCONSIN 53708
(888) 702-9915
www.totalwall.com

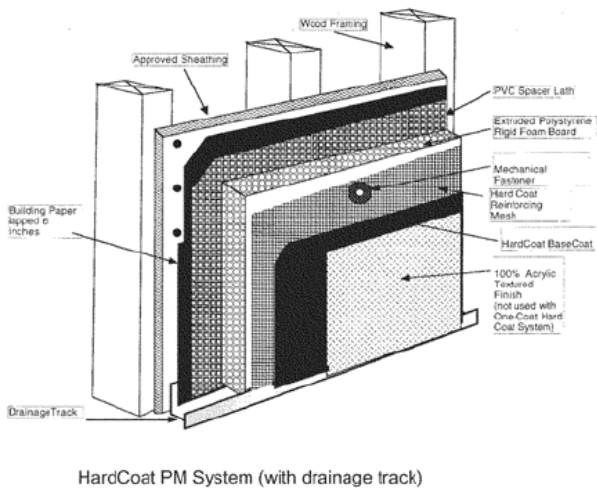

HardCoat PM System (with drainage track)

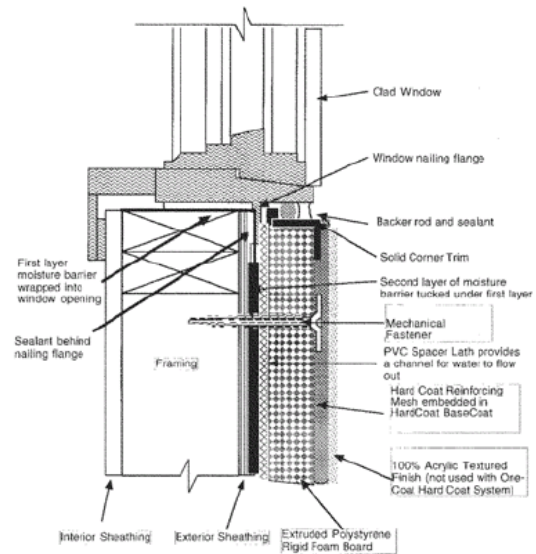

Typical HardCoat PM Window Sill Detail

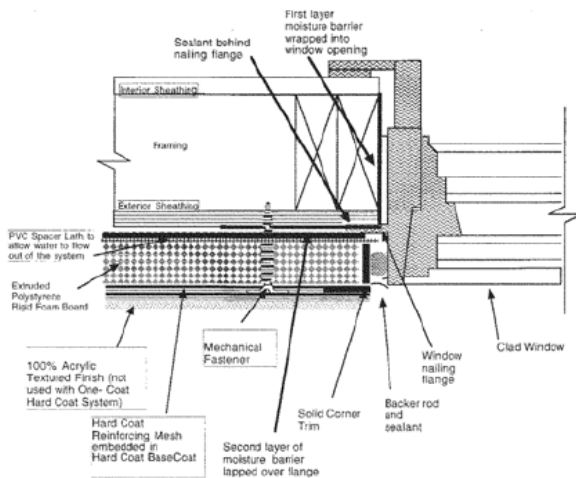

Typical HardCoat PM Window Jamb Detail

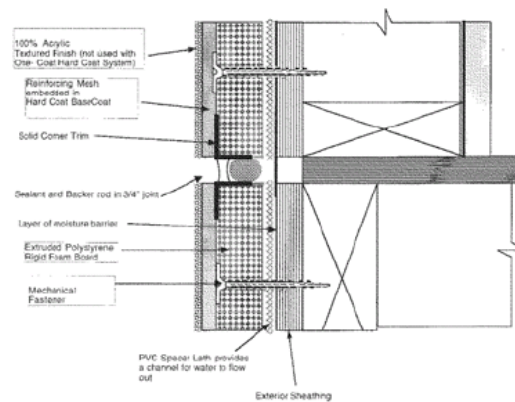

Typical HardCoat PM System Floorline Expansion Joint Detail

FIGURE 1—TYPICAL HARDCOAT PM INSTALLATION DETAILS

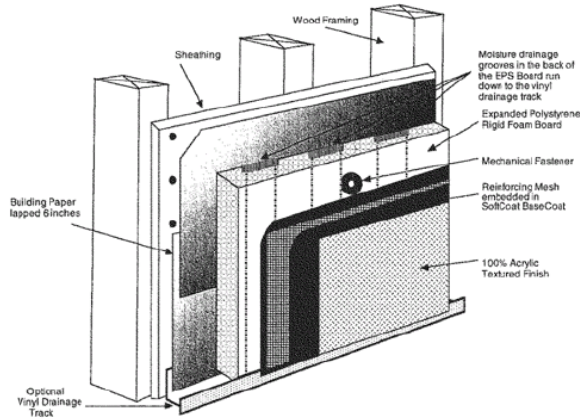

Vertical Moisture Drainage System with Drainage Track

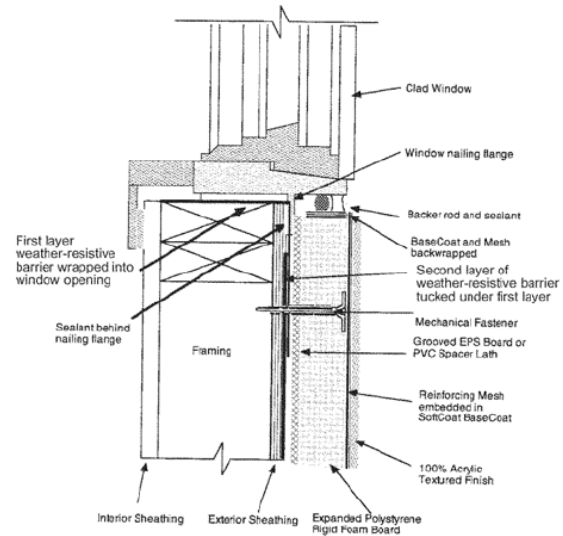

Typical Moisture Drainage Window Sill Detail

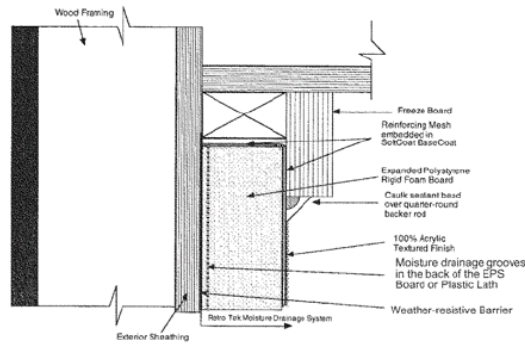

Typical Moisture Drainage Soffit Termination

FIGURE 2—TYPICAL MOISTURE DRAINAGE MD SYSTEM INSTALLATION DETAILS

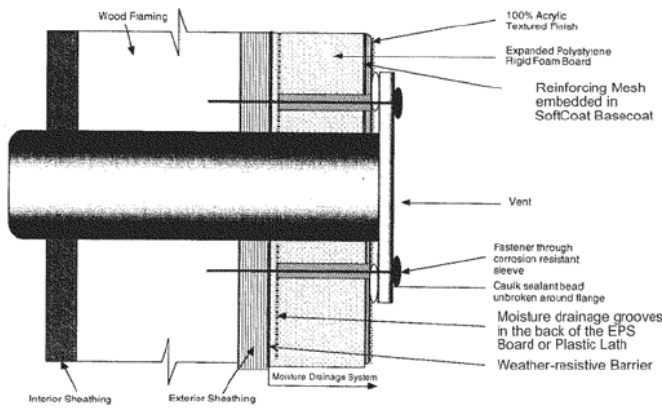

Typical Vent Detail

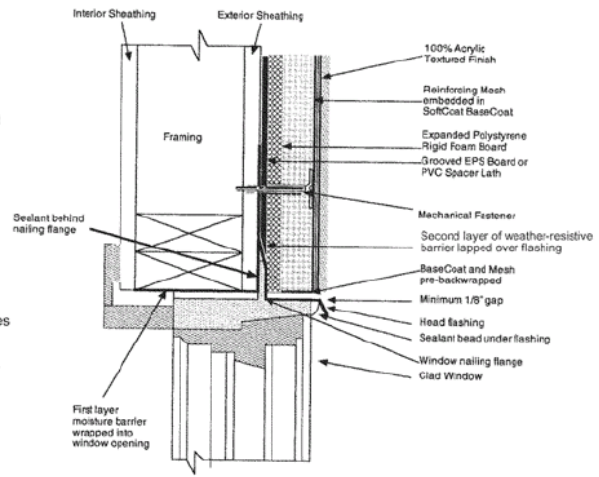

Typical Moisture Drainage Window Head Detail

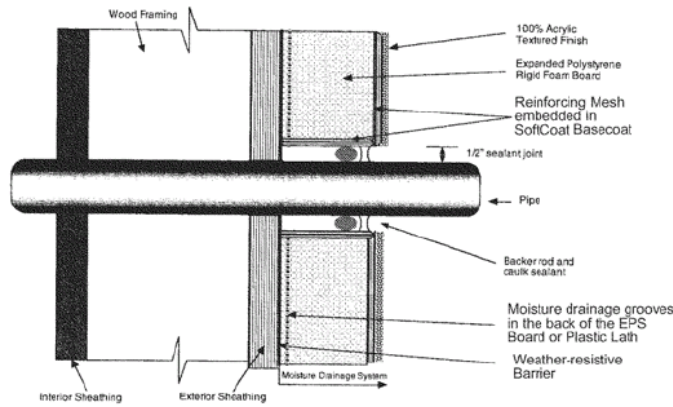

Typical Pipe or Conduit Penetration

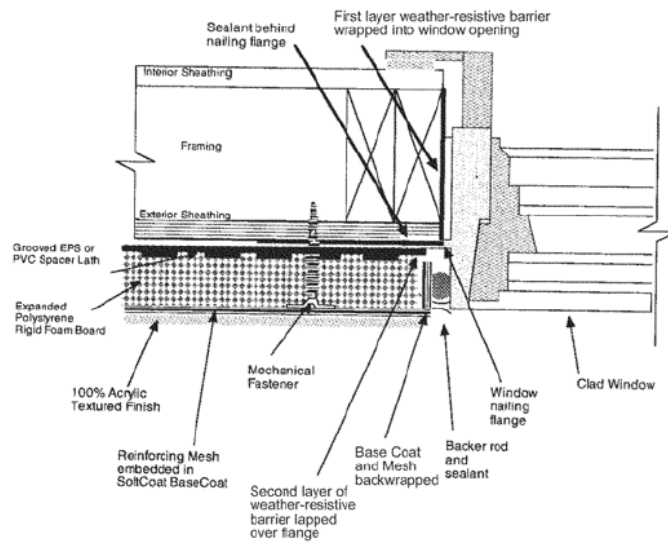

Typical Moisture Drainage Window Jamb Detail

FIGURE 2—TYPICAL MOISTURE DRAINAGE MD SYSTEM INSTALLATION DETAILS (Continued)

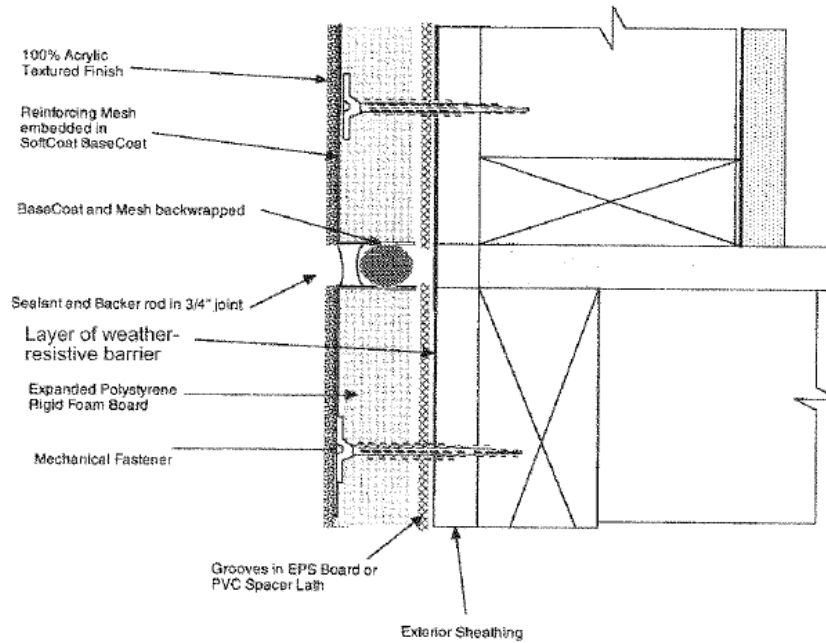

Typical Moisture Drainage System
Floorline Expansion Joint Detail

FIGURE 2—TYPICAL MOISTURE DRAINAGE MD SYSTEM INSTALLATION DETAILS (Continued)

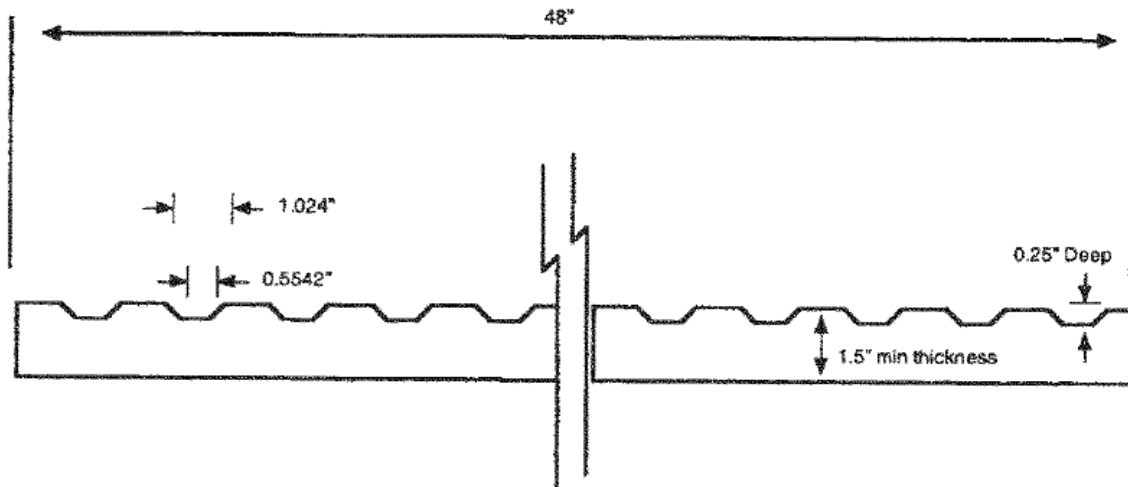

EPS Foam for Moisture Drainage EIFS. Boards are 2' x 4' with 33.5 vents or grooves per board. Grooves are designed so that channels are created no matter how with boards are aligned during installation.

FIGURE 3—GROOVED EPS FOAM

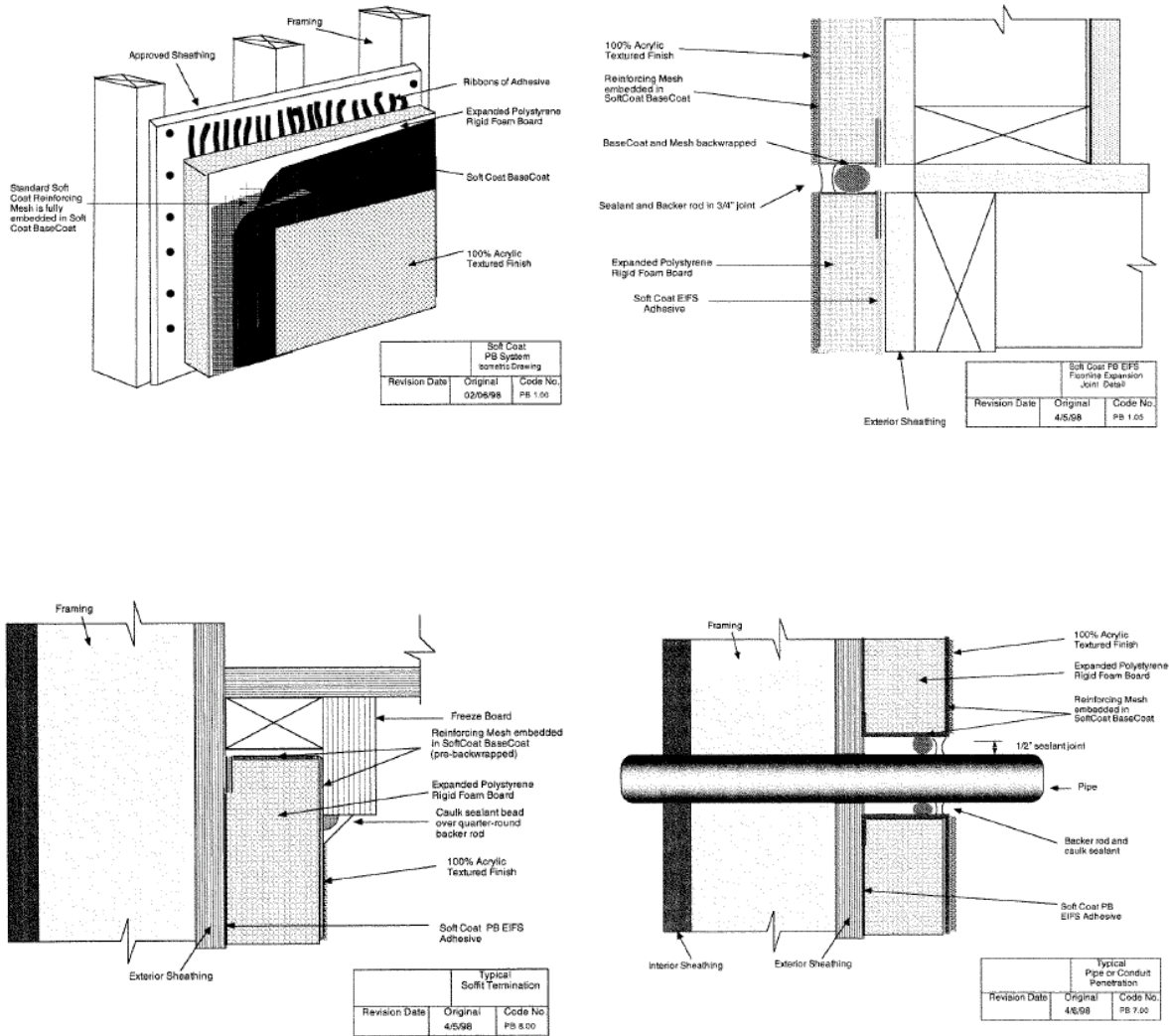

FIGURE 4—SOFTCOAT PB SYSTEM—TYPICAL DETAILS

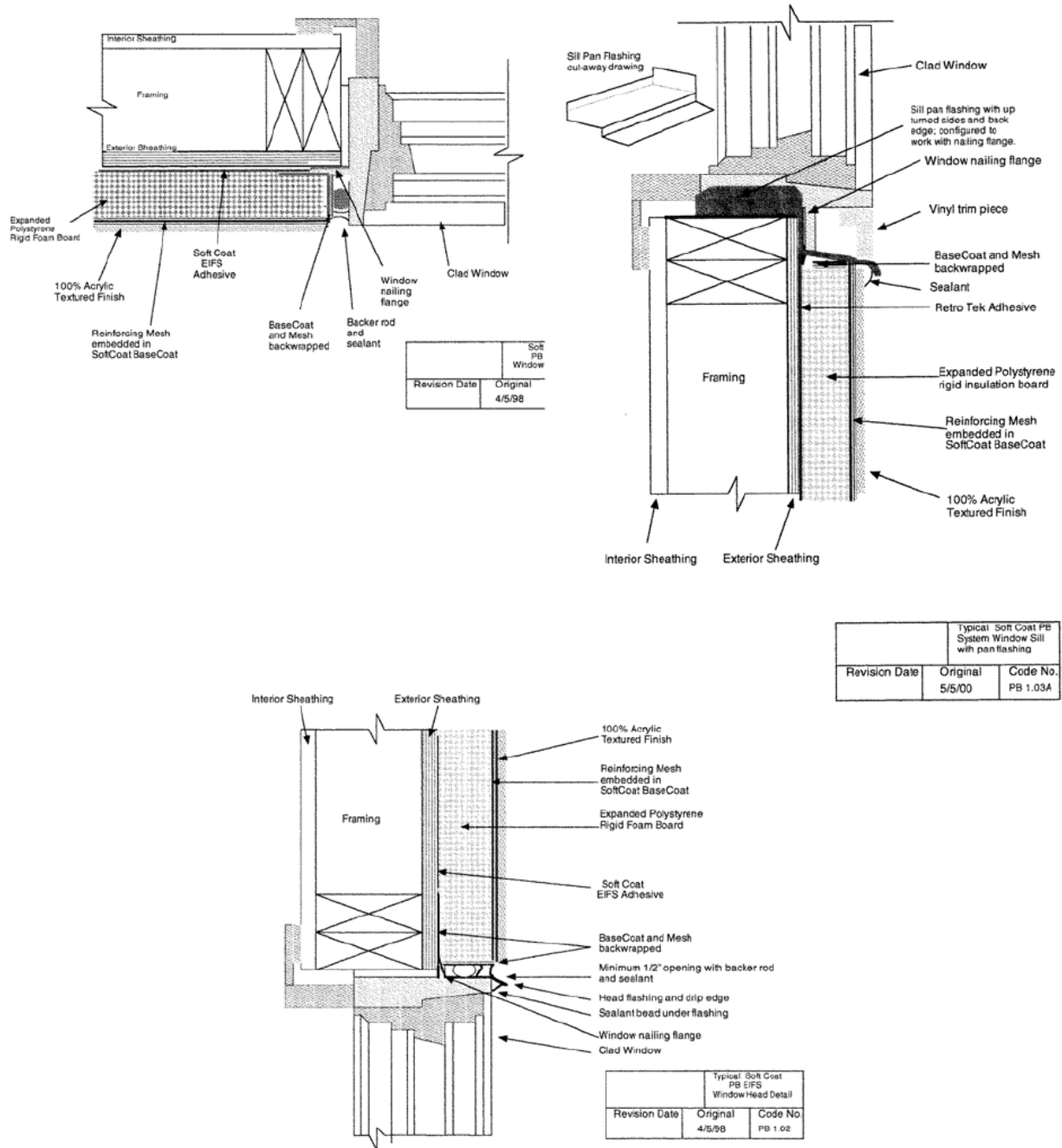

FIGURE 4—SOFTCOAT PB SYSTEM—TYPICAL DETAILS (Continued)

(EIFS CONTRACTOR NAME)

Completion Date: _____

THE EXTERIOR INSULATION AND FINISH SYSTEM (EIFS) INSTALLED ON THE STRUCTURE LOCATED AT THE ADDRESS INDICATED BELOW:

_____ CONFORMS

TO (EIFS MANUFACTURER NAME) RECOMMENDED INSTALLATION PRACTICES AND SECTION(S) _____ OF ICC-ES, INC., EVALUATION REPORT ESR-_____.

Address of Structure

Product Component Names:

Adhesive (s) _____
Fasteners (mech) _____
Base Coat _____
Reinforcing Fabric _____
Finish Coat(s) _____
Weather-resistive Barrier _____

INSTALLATION

CONFORMS

- A. Substrate Type and Tolerance _____
- B. Water-resistive Coating _____
- C. EIFS
 - 1. Adhesive and/or Fasteners _____
 - 2. Insulation _____
 - 3. Reinforcing Fabric _____
 - 4. Base Coat _____
 - 5. Finish _____
 - 6. Weather-resistive Barrier _____

D. The information entered above is offered in testimony that the EIFS installation conforms with the EIFS manufacturer's installation methods and procedures, and the EIFS manufacturer's ES report.

NOTE: An installation card shall be received from the Sealant Installer indicating that the sealant installation conforms with the EIFS evaluation report and sealant manufacturer's installation methods and procedures must accompany this declaration.

EIFS Contractor Company Name and Address:

Signature of Responsible Officer: _____

Typed Name and Title of Officer: _____

Telephone Number: (____) _____

Transmittal: Original: Building Department (Must be submitted with sealant installer declaration.)
Copy: EIFS Manufacturer

FIGURE 5—CONTRACTOR INSTALLATION CARD

(SEALANT INSTALLER NAME)

Completion Date: _____

THE SEALANT INSTALLED IN CONJUNCTION WITH AN EXTERIOR INSULATION AND FINISH SYSTEM (EIFS) INSTALLED ON THE STRUCTUIRE LOCATED AT THE ADDRESS INDICATED BELOW:

_____ CONFORMS

TO (EIFS MANUFACTURER NAME) AND (SEALANT MANUFACTURER'S NAME) RECOMMENDED INSTALLATION PRACTICES AND SECTION(S) _____ OF ICC-ES, INC., EVALUATION REPORT ESR-____.

Address of Structure

Product Component Names:

Primer(s) _____
Sealers _____
Bond Brakers _____
Sealant Materials _____

INSTALLATION

CONFORMS

- A. Designer's requirements, details and instructions _____
- B. Sealant manufacturer's details and requirements _____
- C. Exterior insulation manufacturer's requirements _____

D. The information entered above is offered in testimony that the Sealant installation conforms with the sealant manufacturer's installation methods and procedures, and the EIFS manufacturer's evaluation report.

Sealant Installer Company Name and Address:

Signature of Responsible Officer: _____

Typed Name and Title of Officer: _____

Telephone Number: (____) _____

Transmittal: Original: Building Department (Must be submitted with EIFS contractor declaration.)

Copies: EIFS Manufacturer, EIFS Contractor, and Sealant Manufacturer

FIGURE 6—SEALANT INSTALLATION CARD