

ICC-ES Evaluation Report

ESR-2848*

Issued June 1, 2009

This report is subject to re-examination in one year.www.icc-es.org | (800) 423-6587 | (562) 699-0543

A Subsidiary of the International Code Council®

DIVISION: 06—WOOD AND PLASTICS
Section: 06060—Connections and Fasteners**REPORT HOLDER:****EARTHBOUND CORPORATION**
17361 TYE STREET S.E.
MONROE, WASHINGTON 98272
(360) 863-0722
(800) 944-5669
www.holdown.com**EVALUATION SUBJECT****SLACKJACK® SHRINKAGE COMPENSATING DEVICE****1.0 EVALUATION SCOPE****Compliance with the following codes:**

- 2006 *International Building Code*® (IBC)
- 2006 *International Residential Code*® (IRC)

Property evaluated

Structural

2.0 USES

SlackJack® shrinkage compensating devices are used in conjunction with hold-down and tension tie connectors or a continuous tie-down system for wood frame construction. The devices are installed as components of the restraint system, with the threaded anchor bolts or rods passing through the axis of the devices, to remove slack in the restraint system that occurs due to wood shrinkage or building settlement, or both.

3.0 DESCRIPTION**3.1 General:**

The SlackJack® is a factory-assembled, preloaded, compression-controlled shrinkage and settlement compensating device that can be used with hold-down connectors or tension tie connectors with threaded rods or threaded anchor bolts. The devices are cylindrical, and automatically expand axially along a rod or bolt, to eliminate any gaps between a bearing surface or plate and the nut on the threaded rod or bolt when shrinkage or settlement occurs within the structure. A portion of the SlackJack® is color-coded to identify the specific model number. Model numbers beginning with an "A" or "T" have aluminum bodies, and are designed for use with W3 through W10 swivel washers capable of fitting over

threaded rods or bolts having diameters ranging from $\frac{3}{8}$ inch to $1\frac{1}{4}$ inches (9.5 mm to 32 mm). Model numbers beginning with an "S" or "X" have steel bodies, and are designed for use with W10 or W12 swivel washers capable of fitting over threaded rods or bolts having diameters of $1\frac{1}{4}$ inches and $1\frac{1}{2}$ inches (32 mm and 38 mm), respectively. Model numbers beginning with an "M" (MiniJack™) have aluminum bodies, are designed for use without swivel washers, and will fit over threaded rods or bolts having diameters of $\frac{3}{8}$ inch and $1\frac{1}{2}$ inch (9.5 mm and 12.7 mm). See Figure 1 for diagrams of each model type. See Table 1 for recognized models, and their corresponding color codes and dimensions. The SlackJack® "A", "T", "S" and "X" series are supplied with swivel washers, which are used to center the device on the threaded rod or bolt. Swivel washers are color-coded, as noted in Table 1, to indicate the corresponding appropriate threaded rod or bolt diameter. The SlackJack® "M" and A620 series are supplied with color-coded compression springs, as noted in Table 1, to indicate the specific model and rated compensation capacity.

3.2 Materials:

For the SlackJack® model numbers beginning with an "A", "T" or "M", the inner and outer cylinder bodies of the SlackJack® shrinkage compensating devices are manufactured from ASTM B 221-06 6061-T6511 alloy extruded aluminum tubing. Model numbers beginning with an "S" or "X" have inner and outer cylinder bodies manufactured from ASTM A 513-08a, Type 5 DOM steel tubing, as specified in the manufacturer's quality documentation. Locking rings are manufactured from ASTM A 313-08 stainless steel spring wire. The compression spring and pull clip are manufactured from galvanized hard-drawn spring wire. The color-coded capture ring consists of injection-molded plastic. The color-coded swivel washer is manufactured from ASTM A 108-07, grade 12L14 steel. A hex nut conforming to ASTM A 563-07 is included in the packaging of each device.

4.0 DESIGN AND INSTALLATION**4.1 Design:**

The allowable compression loads, corresponding deflections at allowable loads, and rated shrinkage and settlement compensation capacities for the SlackJack® shrinkage compensating devices designed under allowable stress design are as shown in Table 1. The devices are used where the expected shrinkage or settlement does not exceed their rated compensation capacities. Calculations, demonstrating that the applied loads do not exceed the

***Revised March 2010**

tabulated allowable loads, and that the expected slack due to wood shrinkage and building settlement does not exceed the rated compensation capacity for the SlackJack® shrinkage compensating devices, must be submitted to the code official for approval. Supports must be designed in accordance with the applicable code to transfer loads into the restraint system. The calculations must be prepared by a registered design professional when required by the statutes of the jurisdiction in which the project is to be constructed.

4.2 Installation:

The SlackJack® shrinkage compensating devices must be installed in accordance with this report and the manufacturer's published installation instructions. The devices must be installed over the hold-down or a bearing surface or plate, with the threaded rod or bolt running through its axis. For the SlackJack® "A", "T", "S" and "X" series, the appropriate color-coded swivel washer corresponding to the threaded rod or bolt diameter, as indicated in Table 1, must be installed over each SlackJack® device, with the flat side facing up. The steel hex nut must be screwed onto the threaded rod or bolt, and hand-tightened over the top of the swivel washer. Once the hex nut is hand-tightened onto the swivel washer, the device must be activated by removal of the factory-installed pull clip.

5.0 CONDITIONS OF USE

The SlackJack® shrinkage compensating devices described in this report comply with, or are suitable alternatives to what is specified in, those codes listed in Section 1.0 of this report, subject to the following conditions:

- 5.1 The SlackJack® shrinkage compensating devices must be installed in accordance with this report, the manufacturer's installation instructions and the plans approved by the code official. In the event of a conflict between this report and the manufacturer's published installation instructions, this report governs.
- 5.2 The design values given in this report are for the SlackJack® shrinkage compensating devices alone. No further increase in allowable capacity is permitted. Design must be performed in accordance with Section 4.1 of this report.

- 5.3 Calculations in accordance with Section 4.1 of this report must be submitted to the code official for approval.
- 5.4 The SlackJack® devices are limited to installations in dry, interior locations.
- 5.5 The SlackJack® shrinkage compensating devices must not be used to support dead loads other than their own weight.
- 5.6 Use of the SlackJack® shrinkage compensating devices in direct contact with fire-retardant-treated wood or preservative-treated wood is outside of the scope of this report.
- 5.7 When the SlackJack® shrinkage compensating devices are used as fasteners independent of a continuous tie-down system, the applied loads must not exceed the allowable loads noted in this report.

6.0 EVIDENCE SUBMITTED

Data in accordance with the ICC-ES Acceptance Criteria for Shrinkage Compensating Devices (AC316), dated February 2008.

7.0 IDENTIFICATION

Each SlackJack® shrinkage compensating device bears a label, either on the body of the device or on the packaging, with the evaluation report holder name (Earthbound) and Web address, the product name (SlackJack®), and the evaluation report number (ESR-2848). The devices are color-coded, as indicated in Table 1, to identify the specific model and series number. SlackJack® shrinkage compensating devices are packaged together in a common box or container, which includes corresponding swivel washers and nuts labeled in separate plastic packaging. The SlackJack® "M" series (MiniJack™) devices are packaged in lots of five, and do not require a swivel washer.

TABLE 1—SLACKJACK® SHRINKAGE COMPENSATING DEVICE SPECIFICATIONS

| MODEL AND SERIES NUMBER | CAPTURE RING COLOR CODE | SPRING COLOR CODE | NOMINAL DIMENSIONS ³ (inches) | | | RATED COMPENSATION CAPACITY (inches) | ALLOWABLE COMPRESSION LOAD ^{1,2,4} (lbs) | DEFLECTION AT ALLOWABLE LOAD (inch) |
|-------------------------|-------------------------|-------------------|--|----------------------------|----------------------------|--------------------------------------|---|-------------------------------------|
| | | | Height Before Activation (A) | Outer Diameter of Body (B) | Inner Diameter of Body (C) | | | |
| M100 ⁶ | N/A | Red | 2.215 | 1.349 | 0.407 | 1.0 | 3,500 | 0.017 |
| M175 ⁶ | N/A | Green | 2.965 | 1.349 | 0.532 | 1.75 | 3,500 | 0.017 |
| A210 | Blue | N/A | 3.330 | 2.365 | 1.420 | 1.0 | 7,360 | 0.013 |
| A21-50 | White | N/A | 3.830 | 2.365 | 1.420 | 1.50 | 8,000 | 0.018 |
| A220 | Yellow | N/A | 4.330 | 2.365 | 1.420 | 2.0 | 7,730 | 0.018 |
| T410 | Orange | N/A | 3.700 | 2.365 | 1.375 | 1.0 | 9,000 | 0.020 |
| T420 | Black | N/A | 4.700 | 2.365 | 1.375 | 2.0 | 9,000 | 0.018 |
| A410 | Red | N/A | 3.800 | 2.365 | 1.250 | 1.0 | 14,000 | 0.022 |
| A420 | Green | N/A | 4.800 | 2.365 | 1.250 | 2.0 | 14,000 | 0.030 |
| A430 | Brown | N/A | 5.800 | 2.365 | 1.250 | 3.0 | 14,750 | 0.033 |
| T610 | Gray | N/A | 4.325 | 2.365 | 1.250 | 1.0 | 15,000 | 0.019 |
| T620 | Purple | N/A | 5.325 | 2.365 | 1.250 | 2.0 | 15,000 | 0.019 |
| A610 | Tan | N/A | 4.800 | 2.365 | 1.250 | 1.0 | 20,340 | 0.028 |
| A620 | White | Blue | 5.800 | 2.365 | 1.250 | 2.0 | 20,100 | 0.038 |
| S410 ⁵ | Blue | N/A | 3.270 | 2.500 | 1.625 | 1.0 | 22,000 | 0.020 |
| S420 ⁵ | Yellow | N/A | 4.270 | 2.500 | 1.625 | 2.0 | 22,000 | 0.026 |
| X410 ⁵ | Gold | N/A | 3.700 | 2.500 | 1.625 | 1.0 | 34,220 | 0.035 |

MODEL AND SERIES NUMBER NOTATION FOR THE "A", "T", "S" AND "X" SERIES⁶

| A | 2 | 1 | 0 |
|--|---|---|---|
| Model Type: | Series Type: | Rated Compensation Capacity: | Swivel Washer Color Code ^{4,5} : |
| "A" = Aluminum Body "T" = Aluminum Body "S" = Steel Body "X" = Steel Body | 2 = 2 locking rings 4 = 4 locking rings 6 = 6 locking rings | 1 = 1.0 inch 1-5 = 1.50 inches 2 = 2.0 inches 3 = 3.0 inches | 0 = Base Model 3 = 3/8" Rod Orange 4 = 1/2" Rod Purple 5 = 5/8" Rod Black 6 = 3/4" Rod Gray 7 = 7/8" Rod Blue 8 = 1" Rod Yellow 9 = 1 1/8" Rod White 10 = 1 1/4" Rod Green 12 = 1 1/2" Rod Red |

For SI: 1 inch = 25.4 mm, 1 pound = 4.45 N.

¹Tabulated allowable loads are for the SlackJack® shrinkage compensating devices only. The attached components (including anchors, tension rods, bearing plates, wood framing members, etc.) must be designed to resist design loads in accordance with the applicable code.

²No further increases to the tabulated allowable loads are permitted.

³See Figure 1 for dimensioned drawings of the SlackJack® shrinkage compensating devices.

⁴A swivel washer, having the appropriate inner diameter corresponding to the threaded rod or bolt diameter as indicated under the Swivel Washer Color Code section of the table above, must be used in accordance with Section 4.2. Exception: "M" series devices do not require swivel washers.

⁵Model numbers beginning with an "A" or "T" are designed for use with W3 through W10 swivel washers capable of fitting over threaded rods or bolts having diameters ranging from 3/8 inch to 1 1/4 inches (9.5 mm to 32 mm). Model numbers beginning with an "S" or "X" are designed for use with W10 or W12 swivel washers capable of fitting over threaded rods or bolts having diameters of 1 1/4 inches and 1 1/2 inches (32 mm and 38 mm), respectively.

⁶The model and series number notation given above does not apply to the "M" series (MiniJack™). The M100 and M175 have two locking rings, and rated compensation capacities of 1.0 inch and 1.75 inches, respectively. They are intended for use with either 3/8-inch or 1/2-inch rod diameters.

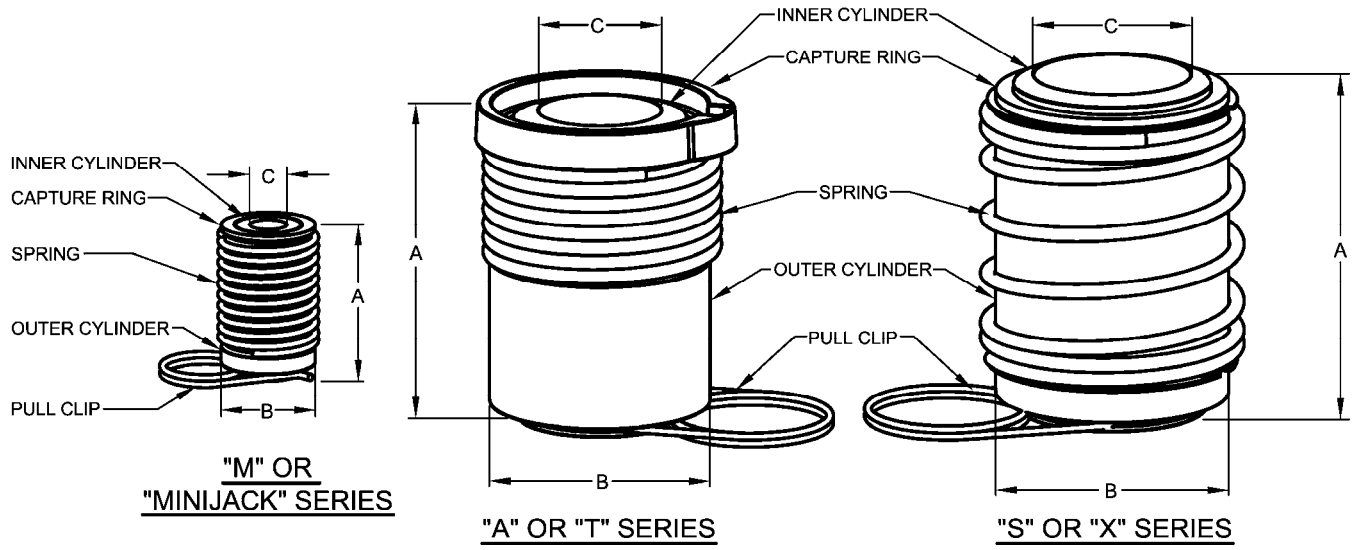

FIGURE 1—SLACKJACK® SHRINKAGE COMPENSATING DEVICES