

Joint Evaluation Report

ESR-2913

Reissued August 2024

This report also contains:

Subject to renewal August 2026

- CBC Supplement
- FBC Supplement
- LABC Supplement

ICC-ES Evaluation Reports are not to be construed as representing aesthetics or any other attributes not specifically addressed, nor are they to be construed as an endorsement of the subject of the report or a recommendation for its use. There is no warranty by ICC Evaluation Service, LLC, express or implied, as to any finding or other matter in this report, or as to any product covered by the report.

Copyright © 2024 ICC Evaluation Service, LLC. All rights reserved.

<p>DIVISION: 06 00 00— WOOD, PLASTICS AND COMPOSITES</p> <p>Section: 06 17 13— Laminated Veneer Lumber</p>	<p>REPORT HOLDER:</p> <p>MURPHY ENGINEERED WOOD PRODUCTS DIVISION</p> <p>ADDITIONAL LISTEES:</p> <p>BLUELINX CORPORATION</p>	<p>EVALUATION SUBJECT:</p> <p>MURPHY LAMINATED VENEER LUMBER (LVL)</p>	
--	--	--	---

1.0 EVALUATION SCOPE

1.1 Compliance with the following codes:

- 2021, 2018, 2015, 2012, 2009 and 2006 [International Building Code® \(IBC\)](#)
- 2021, 2018, 2015, 2012, 2009 and 2006 [International Residential Code® \(IRC\)](#)

For evaluation for compliance with codes adopted by the California Office of Statewide Health Planning and Development (OSHPD) aka: California Department of Health Care Access and Information (HCAI) and Division of the State Architect (DSA), see [ESR-2913 CBC and CRC Supplement](#).

For evaluation for compliance with codes adopted by the [Los Angeles Department of Building and Safety \(LADBS\)](#), see [ESR-2913 LABC and LARC Supplement](#).

Property evaluated:

- Structural

Evaluation to the following green code(s) and/or standards:

- 2022 [California Green Building Standards Code \(CALGreen\)](#), Title 24, Part 11
- 2020, 2015, 2012 and 2008 ICC 700 [National Green Building Standard™](#) (ICC 700-2020, ICC 700-2015, ICC 700-2012, and ICC 700-2008)

Attributes verified:

- See Section 3.1.

2.0 USES

Murphy LVL is an alternative to sawn lumber for structural applications including beams, headers, joists, and rafters. Murphy LVL is also used for components of built-up structural members, such as flanges for I-joists and chords for trusses.

3.0 DESCRIPTION

3.1 General:

Murphy LVL complies with the requirements noted in Section 2303.1.10 of the 2021, 2018 and 2015 IBC (Section 2303.1.9 of the 2012, 2009, and 2006 IBC) for allowable stress design (Section 2301.2). Chapters 5 and 8 of the IRC are applicable to Murphy LVL.

The wood veneer properties and species, adhesive, manufacturing parameters, and finished product thickness, width and length meet the requirements noted in the quality manual that contains the manufacturing standard.

The attributes of the Murphy LVL have been verified as conforming to the provisions of (i) CALGreen Section A4.404.3 for efficient framing techniques; (ii) ICC 700-2020 Sections 608.1(2), 11.608.1(2) and 13.104.3.1(4); (iii) ICC 700-2015 and ICC 700-2012 Sections 608.1(2), 11.608.1(2) and 12(A).608.1 for resource-efficient materials; and (iv) ICC 700-2008 Section 607.1(2) for resource-efficient materials. Note that decisions on compliance for those areas rest with the user of this report. The user is advised of the project-specific provisions that may be contingent upon meeting specific conditions, and the verification of those conditions is outside the scope of this report. These codes or standards often provide supplemental information as guidance.

3.2 Material:

Murphy LVL is made with layers of wood veneers laminated together using an exterior-type heat durable phenol-formaldehyde adhesive conforming to ASTM D2559. Murphy LVL is available in thicknesses from 1¹/₄ inches (32 mm) to 3¹/₂ inches (89 mm), depths from 1¹/₂ inches (39 mm) to 48 inches (1219 mm), and lengths up to 80 feet (24 m).

4.0 DESIGN AND INSTALLATION

4.1 Design:

4.1.1 General: Murphy LVL is designed as structural composite lumber in accordance with the applicable code and the *National Design Specification[®] for Wood Construction* (NDS). Reference design values are as noted in [Table 1](#).

4.1.2 Fasteners: Reference design values for connections must be determined in accordance with the applicable section of the NDS, using the equivalent specific gravities provided in [Table 2](#). Spacing, edge distance and end distance of fasteners installed in the faces and edges of Murphy LVL members must be in accordance with the NDS and are limited as shown in [Table 3](#).

4.2 Installation:

Murphy LVL must be installed in accordance with this evaluation report, applicable building codes and the specifications of the design professional responsible for the design of the structure. Drawings and/or the manufacturer's published installation instructions must be available on the jobsite during installation.

5.0 CONDITIONS OF USE:

The Murphy LVL described in this report complies with, or is a suitable alternative to what is specified in, those codes listed in Section 1.0 of this report, subject to the following conditions:

- 5.1** Calculations and drawings demonstrating compliance with this report must be submitted to the code official. The calculations and drawings must be prepared by a registered design professional where required by the statutes of the jurisdiction in which the project is to be constructed.
- 5.2** The material is limited to conditions in which the average equilibrium moisture content of solid-sawn lumber is less than 16 percent.
- 5.3** Connections other than the nailed and bolted connections described in this report are outside of the scope of this report.
- 5.4** Evaluation of the effect of fire-retardant or preservative treatment on LVL is outside the scope of this report.
- 5.5** Installation, fabrication, identification, and connection details must be in accordance with this report, the manufacturer's published installation instructions and the applicable code. This report must govern if there are conflicts between the manufacturer's published installation instructions and this report.
- 5.6** Murphy LVL is produced in Sutherlin, Oregon, under a quality control program with inspections by ICC-ES and APA—The Engineered Wood Association (AA-649).

6.0 EVIDENCE SUBMITTED

Data in accordance with the [ICC-ES Acceptance Criteria for Structural Wood-based Products \(AC47\)](#), dated June 2017 (editorially revised February 2021).

7.0 IDENTIFICATION

- 7.1 The ICC-ES mark of conformity, electronic labeling, or the evaluation report number (ICC-ES ESR-2913) along with the name, registered trademark, or registered logo of the report holder must be included in the product stamps.
- 7.2 In addition, the Murphy LVL must be identified with product stamps bearing the Murphy Engineered Wood Division name (or the name of one of the listees noted at the beginning of this report; grade; mill number (1089), production shift and date of manufacture; and the name of the inspection agency [APA—The Engineered Wood Association (AA-649)]).
- 7.3 The report holder's contact information is the following:

MURPHY ENGINEERED WOOD PRODUCTS DIVISION
412 WEST CENTRAL AVENUE
SUTHERLIN, OREGON 97479
(541) 459-4545
www.murphyplywood.com

- 7.4 The additional listees' contact information is the following:

BLUELINX CORPORATION
1950 SPECTRUM CIRCLE
MARIETTA, GEORGIA 30067

TABLE 1—REFERENCE DESIGN PROPERTIES (ALLOWABLE STRESS DESIGN) FOR MURPHY LVL^{1,2,3}

PROPERTY		DESIGN STRESS (psi)						
		2,250F _b -1.5E	2,750 F _b -1.8E	2,850 F _b -1.9E	2,950 F _b -2.0E	3,100 F _b -2.0E	3,100 F _b -2.1E	3,100 F _b -2.2E
Bending (F _b)	Joist ⁴	2,250	2,750	2,850	2,950	3,100	3,100	3,100
	Plank	2,200	2,750	2,800	2,950	3,100	3,100	3,100
Tension parallel to grain (F _t) ⁵		1,350	1,950	1,950	2,100	2,100	2,100	2,100
Longitudinal shear (F _v)	Joist	285	285	285	290	290	290	290
	Plank	150	150	150	150	150	150	150
Compression parallel (F _c)		2,350	2,350	2,350	3,200	3,200	3,200	3,200
Compression perpendicular (F _{c⊥})	Joist	750	750	750	750	750	750	750
	Plank	450	450	550	550	550	550	550
Modulus of Elasticity ⁶ , E	Joist	1.5 x 10 ⁶	1.8 x 10 ⁶	1.9 x 10 ⁶	2.0 x 10 ⁶	2.0 x 10 ⁶	2.1 x 10 ⁶	2.2 x 10 ⁶
	Plank	1.4 x 10 ⁶	1.8 x 10 ⁶	1.9 x 10 ⁶	2.0 x 10 ⁶	2.0 x 10 ⁶	2.1 x 10 ⁶	2.2 x 10 ⁶

For SI: 1 psi = 6.9 kPa.

¹The tabulated values are design values for normal duration of load. All values, except for E and F_{c⊥}, may be adjusted for other load durations as permitted by the code. The design stresses are limited to conditions in which the average equilibrium moisture content of solid-sawn lumber is less than 16 percent.

²Reference design values must be adjusted, as applicable, in accordance with Section 8.3 of the NDS.

³Joist = load parallel to gluelines. Plank = load perpendicular to gluelines.

⁴The tabulated values are based on a reference depth of 12 inches. For other depths, when loaded edgewise, the allowable bending stress (F_b) shall be modified by (12/d)^{0.18} where d = depth in inches. For depths less than 2 1/2 inches, the factor for the 2 1/2-inch depth must be used.

⁵The values published in Table 1 are based on a reference length of 3 feet. For other lengths, the allowable tensile stress must be modified by (3/l)^{0.11}, where l = length in feet. For lengths less than 3 feet, the unadjusted allowable tension stresses in Table 1 are used.

⁶The reference E values are the apparent moduli of elasticity, which include the effects of shear deformation. When calculating total deflection, standard engineering formulae for the pure bending deflection are sufficient.

TABLE 2—FASTENER DESIGN FOR MURPHY LVL: EQUIVALENT SPECIFIC GRAVITY¹

NAILS				BOLTS	
Withdrawal Load		Lateral Load		Lateral Load	
Installed in Edge	Installed in Face	Installed in Edge	Installed in Face	Installed in Face	
				Parallel to Grain	Perpendicular to Grain
0.49	0.50	0.50	0.50	0.50	0.50

¹Fastener values based on the equivalent specific gravities in the above table are for normal load duration and may be adjusted using the load duration factors in accordance with the code.

TABLE 3—MINIMUM ALLOWABLE NAIL SPACINGS FOR MURPHY LVL¹

THICKNESS (in.)	ORIENTATION	NAIL SIZE ^{2,3} (COMMON OR BOX)	MINIMUM END DISTANCE (in.)	MINIMUM NAIL SPACING (IN.)	
				Single Row	Multiple Rows ^{4,5}
1 1/4 ≤ thickness < 1 1/2	Edge ⁶	8d and smaller	2 1/2	4	NR ⁸
		10d and 12d	2 1/2	4	
		16d	3 1/2	5	
	Face ⁷	8d and smaller	1 1/2	3	3
		10d and 12d	1 1/2	3	3
		16d	1 1/2	5	5
≥ 1 1/2	Edge ⁶	8d and smaller	2 1/2	3	4
		10d and 12d	3 1/2 ⁹	4	5
		16d	3 1/2	5	6 ¹⁰
	Face ⁷	8d and smaller	1 1/2	3	3
		10d and 12d	1 1/2	3	3
		16d	1 1/2	5	5

For SI: 1 inch = 25.4 mm.

¹Edge distance must be sufficient to prevent splitting.

²16d sinkers (0.148 inch x 3 1/4 inches) may be spaced the same as a 12d common wire nail (0.148 inch x 3 1/4 inches).

³Fastener sizes and closest on-center spacing not specifically described above are beyond the scope of this report.

⁴Multiple rows in the edge orientation must be spaced 1/2 inch or more from each other and offset one-half of the tabulated minimum nail spacing, as shown in Figure 1.

⁵Multiple rows must be equally spaced from the centerline of the narrow face axis.

⁶Nail penetration for edge nailing must not exceed 2 inches for 16d nails (common or box) or 2 1/2 inches for 10d and 12d nails (common or box).

⁷Tabulated closest on-center spacing for face orientation is applicable to nails that are installed in rows parallel to the grain (length) of the LVL. For nails installed in rows perpendicular to the direction of grain (width/depth) of the LVL, the closest on-center spacing for face orientation must be sufficient to prevent splitting of the LVL.

⁸Not recommended.

⁹Minimum end distance may be reduced to 2 1/2 inches for single row nailing.

¹⁰Minimum nail spacing may be reduced to 5 inches when the LVL is 1 3/4 inches or thicker.

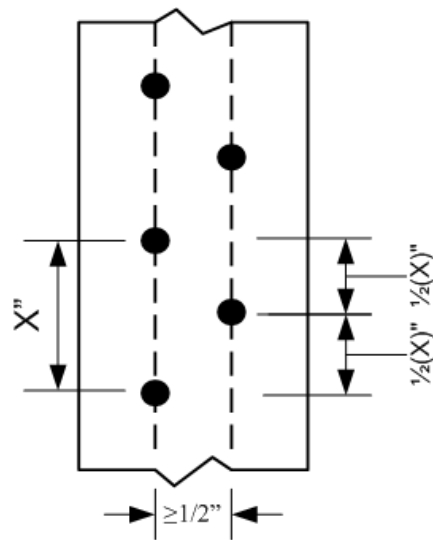

FIGURE 1

DISCLAIMER

APA Product Report[®] is a trademark of APA – *The Engineered Wood Association*, Tacoma, Washington. ICC-ES Evaluation Report is a trademark of ICC Evaluation Service, LLC (ICC-ES). The information contained herein is based on the product evaluation in accordance with the references noted in this report. Neither ICC-ES, nor APA or its members make any warranty, expressed or implied, or assume any legal liability or responsibility for the use, application of, and/or reference to opinions, findings, conclusions, or recommendations included in this report. The joint ICC-ES/APA Evaluation Reports are not to be construed as representing aesthetics or any other attributes not specifically addressed, nor are they to be construed as an endorsement of the subject of the report or a recommendation for its use. Consult the local jurisdiction or design professional to assure compliance with code, construction, and performance requirements. Because neither APA, nor ICC-ES, has any control over quality of workmanship or the conditions under which engineered wood products are used, it cannot accept responsibility for product performance or designs as actually constructed.

DIVISION: 06 00 00—WOOD, PLASTICS AND COMPOSITES
Section: 06 17 13—Laminated Veneer Lumber

REPORT HOLDER:**MURPHY ENGINEERED WOOD PRODUCTS DIVISION****EVALUATION SUBJECT:****MURPHY LAMINATED VENEER LUMBER (LVL)****1.0 REPORT PURPOSE AND SCOPE****Purpose:**

The purpose of this evaluation report supplement is to indicate that Murphy LVL, described in ICC-ES evaluation report [ESR-2913](#), has also been evaluated for compliance with the codes noted below as adopted by the Los Angeles Department of Building and Safety (LADBS).

Applicable code editions:

- 2023 *City of Los Angeles Building Code* (LABC)
- 2023 *City of Los Angeles Residential Code* (LARC)

2.0 CONCLUSIONS

The Murphy LVL, described in Sections 2.0 through 7.0 of the evaluation report [ESR-2913](#), complies with the LABC Chapter 23, and the LARC, and is subject to the conditions of use described in this supplement.

3.0 CONDITIONS OF USE

The Murphy LVL, described in this evaluation report supplement must comply with all of the following conditions:

- All applicable sections in the evaluation report [ESR-2913](#).
- The design, installation, conditions of use and identification are in accordance with the 2021 International Building Code® (IBC) provisions noted in the evaluation report [ESR-2913](#).
- The design, installation and inspection are in accordance with additional requirements of LABC Chapters 16 and 17, as applicable.

This supplement expires concurrently with the evaluation report ESR-2913, reissued August 2024.

DIVISION: 06 00 00—WOOD, PLASTICS AND COMPOSITES
Section: 06 17 13—Laminated Veneer Lumber

REPORT HOLDER:**MURPHY ENGINEERED WOOD PRODUCTS DIVISION****EVALUATION SUBJECT:****MURPHY LAMINATED VENEER LUMBER (LVL)****1.0 REPORT PURPOSE AND SCOPE****Purpose:**

The purpose of this evaluation report supplement is to indicate that the Murphy LVL, described in ICC-ES evaluation report ESR-2913, has also been evaluated for compliance with the code(s) noted below.

Applicable code editions:

- 2022 California Building Code (CBC)
- 2022 California Residential Code (CRC)

For evaluation of applicable chapters adopted by the California Office of Statewide Health Planning and Development (OSHPD) AKA: California Department of Health Care Access and Information (HCAI) and the Division of State Architect (DSA), see Sections 2.1.1 and 2.1.2 below.

2.0 CONCLUSIONS**2.1 CBC:**

The Murphy LVL, described in Sections 2.0 through 7.0 of the evaluation report ESR-2913, complies with CBC Chapter 23, provided the design and installation are in accordance with the 2021 *International Building Code*® (IBC) provisions noted in the evaluation report, ESR-2913, and the additional requirements of CBC Chapters 16 and 17, as applicable.

2.1.1 OSHPD:

The Murphy LVL, described in Sections 2.0 through 7.0 of the evaluation report ESR-2913, complies with CBC amended Chapters 16, 17 and 23, and Chapters 16A and 17A provided the design and installation are in accordance with the 2021 *International Building Code*® (IBC) provisions noted in the evaluation report, and the additional requirements in Section 2.1.1.1 and 2.1.1.2 of this supplement:

2.1.1.1 Conditions of Use:

1. All loads applied shall be determined by the registered design professional and shall comply with applicable loads and load combinations from CBC Chapter 16 and amendments [OSHPD 1R, 2, 3 and 5] and 16A [OSHPD 1 and 4].
2. Conventional light-frame construction under Section 2308 is permitted in accordance with the additional requirements of CBC Section 2308.2.7 [OSHPD 1R, 2 & 5].
3. Seismic Design Category shall be in accordance with CBC amended Section 1613.1 Exception 6 [OSHPD 1R, 2 & 5].
4. Construction documents shall include detailing and limitations for notches and bored holes in accordance with CBC amended Section 2304.4.1 [OSHPD 1, 1R, 2, 4 and 5].
5. When the product is used as chords for trusses, the additional requirements of Section 2303.4.1.4.1 and Section 2303.4.3.1 [OSHPD 1, 1R, 2, 4 & 5] for construction documents shall apply.

2.1.1.2 Special Inspection Requirement: Special inspection of wood structural elements are required in accordance with CBC amended Section 1705A.5.3 [OSHPD 1 & 4].

2.1.2 DSA:

The Murphy LVL, described in Sections 2.0 through 7.0 of the evaluation report ESR-2913, complies with CBC amended Chapters 16 and 23, and Chapters 16A and 17A provided the design and installation are in accordance with the 2021 *International Building Code*® (IBC) provisions noted in the evaluation report, and the additional requirements in Section 2.1.2.1 and 2.1.2.2 of this supplement:

2.1.2.1 Conditions of Use:

1. All loads applied shall be determined by the registered design professional and shall comply with applicable loads and load combinations from CBC amended sections in Chapter 16 [DSA-SS/CC] and 16A [DSA/SS].
2. Conventional light-frame construction under Section 2308, if applicable, shall comply with the additional requirements of CBC Section 2308.2.7 [DSA-SS and DSA-SS/CC].
3. Construction documents shall include detailing and limitations for notches and bored holes in accordance with CBC amended Section 2304.4.1 [DSA-SS and DSA-SS/CC].
4. When the product is used as chords for trusses, the additional requirements of Section 2303.4.1.4.1 and Section 2303.4.3.1 [DSA-SS and DSA-SS/CC] for construction documents shall apply.

2.1.2.2 Special Inspection Requirement: Special inspection of wood structural elements are required in accordance with CBC amended Section 1705A.5.3 [DSA-SS and DSA-SS/CC].

2.2 CRC:

The Murphy LVL described in Sections 2.0 through 7.0 of the evaluation report ESR-2913, complies with CRC Chapters 5 and 8, provided the design and installation are in accordance with the 2021 *International Residential Code*® (IRC) provisions noted in the evaluation report, ESR-2913.

This supplement expires concurrently with the evaluation report ESR-2913, reissued August 2024.

DIVISION: 06 00 00—WOOD, PLASTICS AND COMPOSITES
Section: 06 17 13—Laminated Veneer Lumber

REPORT HOLDER:

MURPHY ENGINEERED WOOD PRODUCTS DIVISION

EVALUATION SUBJECT:

MURPHY LAMINATED VENEER LUMBER (LVL)

1.0 REPORT PURPOSE AND SCOPE**Purpose:**

The purpose of this evaluation report supplement is to indicate that Murphy Laminated Veneer Lumber (LVL), described in ICC-ES evaluation report ESR-2913, has also been evaluated for compliance with the codes noted below.

Applicable code editions:

- 2023 *Florida Building Code—Building*
- 2023 *Florida Building Code—Residential*

2.0 CONCLUSIONS

The Murphy LVL, described in Sections 2.0 through 7.0 of ICC-ES evaluation report ESR-2913, complies with the *Florida Building Code—Building* or the *Florida Building Code—Residential*, provided the design requirements are determined in accordance with the *Florida Building Code—Building* or the *Florida Building Code—Residential*, as applicable. The installation requirements noted in ICC-ES evaluation report ESR-2913 for the 2021 *International Building Code*® meet the requirements of the *Florida Building Code—Building* or the *Florida Building Code—Residential*, as applicable.

Use of the Murphy LVL for compliance with the High-Velocity Hurricane Zone provisions of the *Florida Building Code—Building* and the *Florida Building Code—Residential* has not been evaluated and is outside the scope of this evaluation report.

For products falling under Florida Rule 61G20-3, verification that the report holder's quality assurance program is audited by a quality assurance entity approved by the Florida Building Commission for the type of inspections being conducted is the responsibility of an approved validation entity (or the code official when the report holder does not possess an approval by the Commission).

This supplement expires concurrently with the evaluation report ESR-2913, reissued August 2024.