

ICC-ES Evaluation Report

ESR-2995

Reissued January 2025

Subject to renewal January 2026

ICC-ES Evaluation Reports are not to be construed as representing aesthetics or any other attributes not specifically addressed, nor are they to be construed as an endorsement of the subject of the report or a recommendation for its use. There is no warranty by ICC Evaluation Service, LLC, express or implied, as to any finding or other matter in this report, or as to any product covered by the report.

Copyright © 2025 ICC Evaluation Service, LLC. All rights reserved.

<p>DIVISION: 06 00 00— WOOD, PLASTICS AND COMPOSITES</p> <p>Section: 06 50 00— Structural Plastics</p> <p>Section: 06 63 00— Plastic Railings</p>	<p>REPORT HOLDER:</p> <p>EASTERN WHOLESALE FENCE LLC</p>	<p>EVALUATION SUBJECT:</p> <p>ILLUSIONS® VINYL RAILING SYSTEM™</p>	
--	--	--	---

1.0 EVALUATION SCOPE

1.1 Compliance with the following codes:

- 2012, 2009 and 2006 [International Building Code® \(IBC\)](#)
- 2012, 2009 and 2006 [International Residential Code® \(IRC\)](#)
- 2013 *Abu Dhabi International Building Code (ADIBC)*[†]

[†]The ADIBC is based on the 2009 IBC. 2009 IBC code sections referenced in this report are the same sections in the ADIBC.

Properties evaluated:

- Structural
- Durability
- Surface-burning characteristics

1.2 Evaluation to the following green code(s) and/or standards:

- 2022 [California Green Building Standards Code \(CALGreen\)](#), Title 24, Part 11
- 2020, 2015, 2012 and 2008 ICC 700 [National Green Building Standard™](#) (ICC 700-2020, ICC 700-2015, ICC 700-2012 and ICC 700-2008)

Properties evaluated:

- See Section 3.1

2.0 USES

The Illusions® Vinyl Railing System™ described in this report is for exterior use as guards for balconies, porches, decks and stairs in buildings of Type V-B (IBC) construction and other types of construction in applications where untreated wood is permitted by IBC Section 1406.3 or in buildings constructed in accordance with the IRC.

3.0 DESCRIPTION

3.1 General:

The Illusions® Vinyl Railing System™ is composed of polyvinyl chloride (PVC) which is extruded, in accordance with the approved quality control manual, into prefinished railing system components. The system components are available in white, beige or grey colors.

The attributes of the railing system have been verified as conforming to the provisions of (i) CALGreen Section A5.406.1.2 for reduced maintenance; (ii) ICC 700-2020 Sections 602.1.6 and 11.602.1.6 for termite-resistant materials and Sections 601.7 and 11.601.7 for site-applied finishing materials (iii) ICC 700-2015 and ICC 700-2012 Sections 602.1.6 and 11.602.1.6 for termite-resistant materials and Sections 601.7, 11.601.7, and 12.1(A).601.7 for site-applied finishing materials; and (iv) ICC 700-2008 Section 602.8 for termite-resistant materials and Section 601.7 for site-applied finishing materials. Note that decisions on compliance for those areas rest with the user of this report. The user is advised of the project-specific provisions that may be contingent upon meeting specific conditions, and the verification of those conditions is outside the scope of this report. These codes or standards often provide supplemental information as guidance. See Section 5.7 for limitations on termite-resistance use.

3.2 Guards:

The Illusions[®] Vinyl Railing System[™] is composed of top rails with aluminum “H” shaped inserts, bottom rails, and either square- or colonial-shaped balusters. The inserts are 1.62 inches (41.1 mm) wide by 3.16 inches (80.3 mm) deep, and have 0.07-inch-thick (1.78 mm) flanges and a 0.10-inch-thick (2.54 mm) web. The inserts are made of ASTM B221, 6005 alloy and T5 aluminum. Four styles of Illusions[™] railings are available: Traditional square balusters with rectangular top rails; Traditional square balusters with T-Rail top rails; Colonial Spindle balusters with rectangular top rails; and Colonial Spindle balusters with T-Rail top rails. The rectangular top rails and the bottom rails are 2 inches (51 mm) wide by 3.5 inches (89 mm) deep. The T-Rail top rails have a wider top, resulting in an overall size of 3.5 inches (89 mm) wide by 3.5 inches (89 mm) deep. The Illusions[®] Vinyl Railing System[™] is recognized for guardrails having a maximum height of 42 inches (1067 mm) as shown in [Table 1](#). The railings provide for 3.375-inch-wide (85.7 mm) openings between the 1½-inch (38.1 mm) square sections of the thermoformed hollow PVC Colonial balusters and the co-extruded hollow PVC Traditional balusters. The bottom and top rails have a 0.12-inch (3.05 mm) wall thickness, and the Traditional and Colonial balusters have a 0.08-inch (2.03 mm) wall thickness. See [Figure 2](#) for typical component cross sections.

The top and bottom rails are fastened to the supporting structure using 2.5-inch-tall-by-2.75-inch-wide (64 mm by 70 mm) nylon brackets. The brackets have four screw holes used to fasten the brackets to the supports, a resting flange at the bottom, and a fastening flange on each side with three slotted screw holes each. The brackets are designed for mounting deck railings and stair railings to fixed wall surfaces or to braced columns.

3.3 Durability:

When subjected to weathering, insect attack and other decaying elements, material used to manufacture the Illusions[®] Vinyl Railing System[™] is equivalent to preservative-treated or naturally durable lumber when used in locations described in Section 2.0 of this report. The Illusions[®] Vinyl Railing System[™] has been evaluated for a temperature range of -20°F to 125°F (-29°C to 52°C).

3.4 Surface-burning Characteristics:

When tested in accordance with ASTM E84, the Illusions[®] Vinyl Railing System[™] has a flame-spread index of no greater than 200.

4.0 DESIGN AND INSTALLATION

4.1 General:

Installation of the Illusions[®] Vinyl Railing System[™] must comply with this report and the manufacturer's published installation instructions. A copy of these instructions must be available on the jobsite at all times during installation. When the manufacturer's published installation instructions differ from this report, this report governs.

4.2 Design:

The Illusions[®] Vinyl Railing System[™] is satisfactory to resist the loads specified in 2009 and 2006 IBC Section 1607.7.1, 2012 IBC Section 1607.8.1 and IRC Table R301.5, when installed at a maximum edge-of-structure-to-edge-of-structure spacing as prescribed in [Table 1](#) of this report.

4.3 Installation:

The Illusions[®] Vinyl Railing System[™] has been evaluated for installation between two fixed points, such as walls or columns. The top rails must be reinforced with aluminum “H” shaped inserts, which are provided with the rails. The rails must be installed using the mounting plates supplied by Eastern Wholesale Fence LLC, mounted on the supports at the appropriate heights for the bottom and top rails, stainless steel screws, as shown in [Table 2](#), supplied by the manufacturer. The rails must be secured to the mounting brackets as required in [Table 2](#), making sure the screws engage and penetrate through the aluminum “H” shaped inserts.

At stairs, the rails are installed in the same manner, with the bottom rail installed 2 inches above the risers. The attachment method described above for brackets to supports is for fasteners embedded into a wood substrate having a specific gravity of 0.50 (minimum), to a minimum depth of 1³/₈ inches (34.9 mm). Additional attachment methods are outside the scope of this report and are required to be submitted to the code official for approval. See [Figure 1](#) for typical railing system installation.

5.0 CONDITIONS OF USE:

The Illusions[®] Vinyl Railing System[™] described in this report complies with, or is a suitable alternative to what is specified in, those codes listed in Section 1.0 of this report, subject to the following conditions:

- 5.1 The Illusions[®] Vinyl Railing System[™] described in this report is limited to exterior use as guards for balconies, porches, decks and stairs in buildings of Type V-B (IBC) construction and other types of construction in applications where untreated wood is permitted by IBC Section 1406.3, or in buildings constructed in accordance with the IRC.
- 5.2 Installation must comply with this report; the manufacturer's published installation instructions and the applicable code. Only those fasteners and fastener configurations described in this report have been evaluated for the installation of the Illusions[®] published installation instructions differ from this report, this report governs.
- 5.3 The determination of compatibility of the fasteners, metal post mount components and other metal hardware with the supporting construction, including chemically treated wood, is subject to approval by the code official.
- 5.4 Adjustment factors outlined in the AF&PA National Design Standard and applicable codes must not apply to the allowable capacity and maximum spans for the Illusions[®] Vinyl Railing System[™].
- 5.5 The Illusions[®] Vinyl Railing System[™] must be fastened directly to supporting construction. Where required by the code official, engineering calculations and construction documents consistent with this report must be submitted for approval. The calculations must verify that the supporting construction complies with applicable building code requirements and is adequate to resist the loads imparted upon it by the products and systems discussed in this report. The documents must contain details of the attachment to the supporting structure consistent with the requirements of this report. The documents must be prepared by a registered design professional where required by the statutes of the jurisdiction in which the project is to be constructed.
- 5.6 The top rail of the Illusions[®] Vinyl Railing System[™] must not be permitted to be used as a handrail for stairways or ramps.
- 5.7 Posts are outside the scope of this report.
- 5.8 The Illusions[®] Vinyl Railing System[™] components are produced in Calverton, New York, under a quality control program with inspections by ICC-ES.

6.0 EVIDENCE SUBMITTED

Data in accordance with the [ICC-ES Acceptance Criteria for Deck Board Span Ratings and Guardrail Systems \(Guards and Handrails\) \(AC174\)](#), dated January 2012.

7.0 IDENTIFICATION

- 7.1 The Illusions[®] Vinyl Railing System[™] components described in this report are identified on each individual piece or on the packaging. The identification includes a production code, the product type, the allowable span, the manufacturer's name (Eastern Wholesale Fence LLC) and/or trademark (see [Figure 3](#)), and the ICC-ES evaluation report number (ESR-2995).
- 7.2 The report holder's contact information is the following:

EASTERN WHOLESALE FENCE LLC
274 MIDDLE ISLAND ROAD
MEDFORD, NEW YORK 11763
(631) 698-0975
www.illusionsvinylrailing.com

TABLE 1—MAXIMUM GUARDRAIL SYSTEM SPANS¹

GUARDRAIL SYSTEM	GUARDRAIL TYPE	APPLICABLE BUILDING CODE ²		MAXIMUM SPAN ^{3,4} (inches)
		IBC	IRC	
Colonial balusters with maximum 42-inch-high Rectangular or T-Rail top rail	Level	Yes	Yes	96
	Level	No	Yes	120
	Stair	Yes	Yes	87.5
Traditional balusters with maximum 42-inch-high Rectangular top rail	Level	Yes	Yes	96
	Level	No	Yes	120
	Stair	Yes	Yes	87.5
Traditional balusters with maximum 42-inch-high T-Rail top rail	Level	Yes	Yes	120
	Stair	Yes	Yes	87.5

For SI: 1 inch = 25.4 mm; 1 ft = 305 mm.

¹The ability of the supporting construction to resist the reaction from guardrail loads must be justified to the satisfaction of the code official.

²Indicates compliance with the respective building codes.

³Maximum allowable span has been adjusted for durability. No further increases are permitted.

⁴Maximum span is measured from edge-of-support-to-edge-of-support.

TABLE 2—REQUIRED FASTENERS

GUARDRAIL SYSTEM	CONNECTION	REQUIRED FASTENERS
Colonial balusters with maximum 42-inch-high Rectangular or T-Rail top rail	Top Rail Bracket to Rail	Two #10 x 3/4-inch self-tapping, pan head, stainless steel screws
Traditional balusters with maximum 42-inch-high Rectangular top rail	Top Rail Bracket to Rail	Two #10 x 3/4-inch self-tapping, pan head, stainless steel screws
Traditional balusters with maximum 42-inch-high T-rail top rail up to 96-inch span	Top Rail Bracket to Rail	Two #10 x 3/4-inch self-tapping, pan head, stainless steel screws
Traditional balusters with maximum 42-inch-high T-Rail top rail up to 120-inch span when connected to wood support	Top Rail Bracket to Rail	Six #10 x 3/4-inch self-tapping, pan head, stainless steel screws
Traditional balusters with maximum 42-inch-high T-Rail top rail up to 120-inch span when connected to Blu-Mount support	Top Rail Bracket to Rail	Four #10 x 3/4-inch self-tapping, pan head, stainless steel screws
All systems	Bottom Rail Bracket to Rail	Two #10 x 3/4-inch self-tapping, pan head, stainless steel screws
All systems	Top and Bottom Rail Mounting Plates to Wood Support ¹	Four #10 x 1 1/2-inch self-tapping, pan head, stainless steel screws
All systems	Top and Bottom Rail Mounting Plates to Blu-Mount Support ²	Four #10 x 1-inch self-tapping, pan head, stainless steel screws

For SI: 1 inch = 25.4 mm; 1 ft = 305 mm.

¹The attachment method described for brackets to support is for fasteners embedded into a wood substrate having a specific gravity of 0.50 (minimum), to a minimum depth of 1 3/8 inches (34.9 mm).

²The attachment method described for brackets to Blu-Mount post mount by LMT-Mercer Group. This report covers the attachment of the rail mounting plate to support only. The design, installation and use of the Blu-Mount post is outside of the scope of this report.

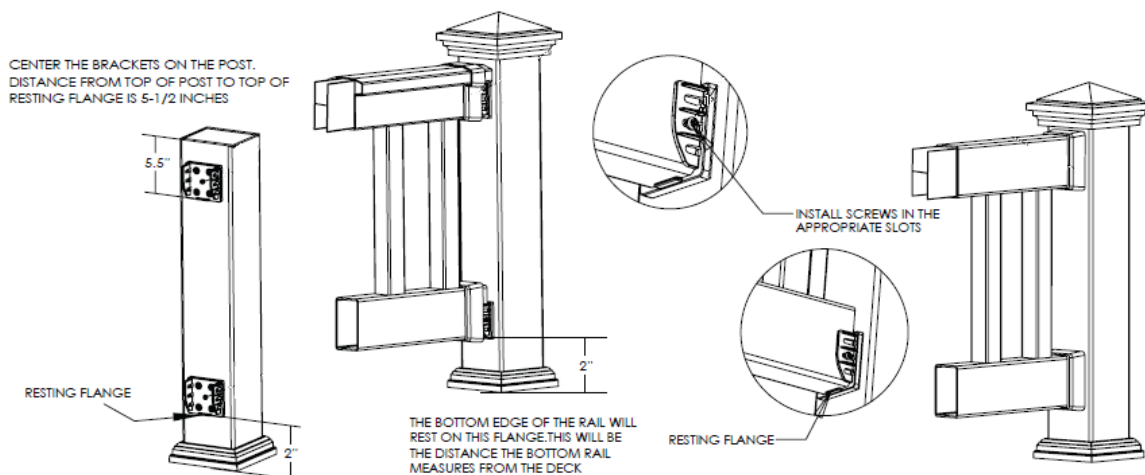

FIGURE 1—TYPICAL GUARDRAIL SYSTEM INSTALLATION

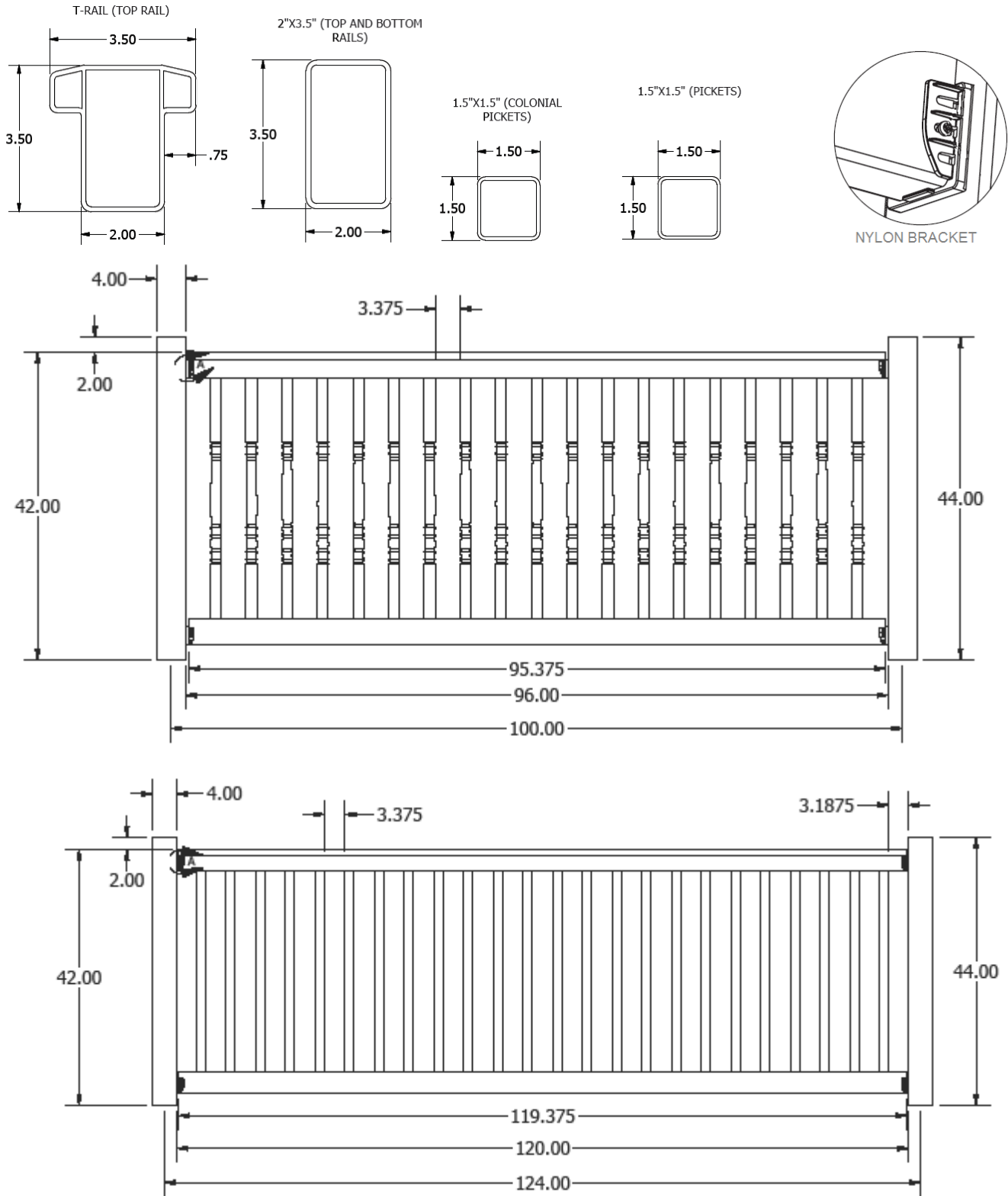

FIGURE 2—TYPICAL GUARDRAIL SYSTEM COMPONENT PROFILES



FIGURE 3—PRODUCT TRADEMARK