

ICC-ES Evaluation Report

ESR-2203*
Issued June 1, 2008
This report is subject to re-examination in one year.
www.icc-es.org | (800) 423-6587 | (562) 699-0543

A Subsidiary of the International Code Council®
DIVISION: 06-WOOD AND PLASTICS
Section: 06090-Wood and Plastic Fastenings
REPORT HOLDER:
SIMPSON STRONG-TIE COMPANY, INC.
5956 WEST LAS POSITAS BOULEVARD
PLEASANTON, CALIFORNIA 94588
(800) 999-5099
www.strongtie.com
EVALUATION SUBJECT:
SIMPSON STRONG-TIE HTU AND LUCZ HANGERS
1.0 EVALUATION SCOPE
Compliance with the following codes:

- 2006 *International Building Code*® (IBC)
- 2006 *International Residential Code*® (IRC)

Property evaluated:

Structural

2.0 USES

The HTU and LUCZ hangers described in this report are used as wood framing connectors in accordance with Section 2304.9.3 of the IBC. The products may also be used in structures regulated under the IRC when an engineered design is submitted in accordance with Section R301.1.3.

3.0 DESCRIPTION
3.1 HTU Hanger Series:

The HTU hangers are face-mounted, and are designed to support trusses installed with full or partial heel heights and gaps of up to, but not exceeding, $\frac{1}{2}$ inch (12.7 mm) and $\frac{1}{8}$ inch (3.2 mm) between the truss and the supporting girders. Minimum and maximum nailing options provide solutions for design with varying heel heights and support conditions. The HTU hangers are formed from No. 16 gage galvanized steel. See Table 1A and Figures 1A and 1B for hanger dimensions, required fastener schedule, allowable loads and an installation detail for installations in which the gap between the truss and the supporting girders is less than or equal to $\frac{1}{2}$ inch (12.7 mm). See Table 1B and Figures 1A and 1B for hanger dimensions, required fastener schedule, allowable loads and an installation detail for installations in which the gap between the truss and the supporting girders is less than or equal to $\frac{1}{8}$ inch (3.2 mm). See Table 1C and Figures 1A and 1C for hanger dimensions, required fastener schedule, allowable loads and

an installation detail for installations in which the minimum allowable number of nails is driven into the supporting girder, and the gap between the truss and supporting girder is less than or equal to $\frac{1}{2}$ inch (12.7 mm).

3.2 LUCZ Hanger Series:

The LUCZ hangers are face-mounted, and are designed to support nominally dimensioned 2-by-6, 2-by-8, 2-by-10 and 2-by-12 beams and joists. LUCZ hangers have concealed flanges to allow for installation near the end of a supporting member such as a ledger or header. The hangers are formed from No. 18 gage galvanized steel. See Table 2 and Figure 2 for hanger dimensions, required fastener schedule, allowable loads and a typical installation detail.

3.3 Materials:

3.3.1 Steel: The HTU hangers are manufactured from galvanized steel complying with ASTM A 653, SS designation, Grade 40, with a minimum yield strength, F_y , of 40,000 psi (275 MPa) and a minimum tensile strength, F_u , of 55,000 psi (379 MPa). The LUCZ hangers are manufactured from galvanized steel complying with ASTM A 653, SS designation, Grade 33, with a minimum yield strength, F_y , of 33,000 psi (227 MPa) and a minimum tensile strength, F_u , of 45,000 psi (310 MPa). Minimum base-metal thicknesses for the hangers in this report are as follows:

NOMINAL THICKNESS (gage)	MINIMUM BASE-METAL THICKNESS (inch)
No. 16	0.0555
No. 18	0.0445

For SI: 1 inch = 25.4 mm.

The hangers have a minimum G90 zinc coating specification in accordance with ASTM A 653. Some models (designated with a model number ending with Z) are available with a G185 zinc coating specification in accordance with ASTM A 653. Some models (designated with a model number ending in HDG) are available with a hot-dip galvanization, also known as "batch" galvanization, in accordance with ASTM A 123, with a minimum specified coating weight of 2.0 ounces of zinc per square foot of surface area (600 g/m²), total for both sides. Model numbers for the HTU series hangers in this report do not include the Z or HDG ending, but the information shown applies. The lumber treater or the holder of this report (Simpson Strong-Tie Company) should be contacted for recommendations on the appropriate level of corrosion resistance to specify for use of steel connectors in contact with the specific proprietary preservative-treated or fire-

***Revised June 2009**

retardant-treated lumber.

3.3.2 Wood: Wood members with which the connectors are used must be either sawn lumber, structural glued laminated timber or engineered lumber having a minimum specific gravity of 0.50 (minimum equivalent specific gravity of 0.50 for engineered lumber), and having a maximum moisture content of 19 percent (16 percent for engineered lumber) except as noted in Section 4.1. The thickness of the supporting wood member (header, beam or ledger) must be equal to or greater than the length of the fasteners specified in the tables in this report, or as required by wood member design, whichever is greater.

Fasteners: Nails used for hangers described in this report must comply with the material requirements, physical properties, tolerances, workmanship, protective coating and finishes, certification, and packaging and package marking requirements specified in ASTM F 1667. The nails must have the following minimum fastener dimensions and bending yield strengths (F_{yb}):

NAIL DESIGNATION	NAIL SHANK DIAMETER (Inch)	NAIL LENGTH	F_{yb} (psi)
10d x 1 ¹ / ₂	0.148	1 ¹ / ₂	90000
10d	0.148	3	90000
16d	0.162	3 ¹ / ₂	90000

For SI: 1 inch = 25.4 mm, 1 lbf/in² = 6.89 kPa.

Fasteners used in contact with preservative-treated or fire-retardant-treated lumber must comply with IBC Section 2304.9.5 or IRC Section R319.3, as applicable. For use with treated lumber, the lumber treater or the holder of this report (Simpson Strong-Tie Company), or both, should be contacted for recommendations on the appropriate level of corrosion resistance to specify for the fasteners as well as the connection capacities of fasteners used with the specific proprietary preservative-treated or fire-retardant-treated lumber.

4.0 DESIGN AND INSTALLATION

4.1 Design:

The tabulated allowable loads shown in Tables 1 through 3 are based on allowable stress design and include the load duration factor, C_D , corresponding with the applicable loads in accordance with the AF&PA National Design Specification for Wood Construction and its supplement (NDS). No further increases are permitted for load durations other than those specified. Tabulated allowable loads apply to products connected to wood with a moisture content of 19 percent or less (16 percent or less for engineered wood) at the time of installation, and used under continuously dry conditions where sustained temperatures are 100°F (37.8°C) or less. When connectors are installed in solid sawn lumber having a moisture content greater than 19 percent, or where wet service is expected, the allowable loads in this evaluation report must be adjusted by the wet service factor, C_M , specified in the NDS for dowel-type fasteners under lateral loads. When connectors are installed in wood that will experience sustained exposure to temperatures exceeding 100°F (37.8°C), the allowable loads in this report must be adjusted by the temperature factor, C_t , specified in the NDS. Connected wood members must be analyzed for load carrying capacity at the connection in accordance with the NDS.

4.2 Installation:

Installation of the connectors must be in accordance with this evaluation report and the manufacturer's published installation instructions. In the event of a conflict between this report and the manufacturer's published installation instructions, this report governs. For installations in engineered lumber, minimum allowable nail or screw spacing and end distances, as specified in the applicable evaluation report for the engineered lumber, must be met.

4.3 Special Inspection:

4.3.1 IBC: For structures regulated under the IBC, periodic special inspection must be provided for components within the seismic-force-resisting system in Seismic Design Category C, D, E or F in accordance with Section 1707.3 or 1707.4, with the exception of those structures that qualify under Section 1704.1.

4.3.2 IRC: For structures regulated under the IRC, special inspections are not required.

5.0 CONDITIONS OF USE

The Simpson Strong-Tie products described in this report comply with, or are suitable alternatives to what is specified in, those codes listed in Section 1.0 of this report, subject to the following conditions:

- The connectors must be manufactured, identified and installed in accordance with this report and the manufacturer's published installation instructions. A copy of the instructions must be available at the jobsite at all times during installation.
- Calculations showing compliance with this report must be submitted to the code official. The calculations must be prepared by a registered design professional where required by the statutes of the jurisdiction in which the project is to be constructed.
- Adjustment factors noted in Section 4.1 and the applicable codes must be considered, where applicable.
- Connected wood members and fasteners must comply, respectively, with Sections 3.3.2 and 3.3.3 of this report.
- Use of connectors with preservative-treated or fire-retardant-treated lumber must be in accordance with Section 3.3.1 of this report. Use of fasteners with preservative-treated or fire-retardant-treated lumber must be in accordance with Section 3.3.3 of this report.

6.0 EVIDENCE SUBMITTED

Data in accordance with the ICC-ES Acceptance Criteria for Joist Hangers and Similar Devices (AC13), dated October 2006 (corrected March 2007; editorially revised April 2008).

7.0 IDENTIFICATION

The products described in this report are identified with a die-stamped label indicating the name of the manufacturer (Simpson Strong-Tie), the model number, and the number of an index evaluation report ([ESR-2523](#)) that is used as an identifier for the products recognized in this report.

TABLE 1A—DIMENSIONS, NAILING SCHEDULES AND DESIGN VALUES FOR HTU SERIES HANGERS
 (1/2 Inch Maximum Gap Between Supporting Member and Supported Member – Maximum Number of Nails into Supporting Member)

MODEL No.	DIMENSIONS ⁴ (inches)			FASTENERS ⁵ (Quantity-Type)		ALLOWABLE LOADS ^{6,7,8} (lbs)						
	W	H	B	Into Supporting Member	Into Supported Member	Uplift ⁹	Download					
						C _D =1.33 or =1.6	C _D =0.9	C _D =1.0	C _D =1.15	C _D =1.25	C _D =1.33	C _D =1.6
Single 2X Sizes												
HTU26 (1/2" Gap – Min Heel) ¹	1 ⁵ / ₈	5 ⁷ / ₁₆	3 ¹ / ₂	20-16d	11-10dx1 ¹ / ₂	670	2660	2735	2735	2735	2735	2735
HTU26 (1/2" Gap – Min Nail) ²	1 ⁵ / ₈	5 ⁷ / ₁₆	3 ¹ / ₂	20-16d	14-10dx1 ¹ / ₂	1175	2660	2940	3100	3100	3100	3100
HTU26 (1/2" Gap – Max Nail) ³	1 ⁵ / ₈	5 ⁷ / ₁₆	3 ¹ / ₂	20-16d	20-10dx1 ¹ / ₂	1215	2660	2940	3340	3600	3760	3760
HTU28 (1/2" Gap – Min Nail) ²	1 ⁵ / ₈	7 ¹ / ₁₆	3 ¹ / ₂	26-16d	14-10dx1 ¹ / ₂	1125	3460	3770	3770	3770	3770	3770
HTU28 (1/2" Gap – Max Nail) ³	1 ⁵ / ₈	7 ¹ / ₁₆	3 ¹ / ₂	26-16d	26-10dx1 ¹ / ₂	1920	3460	3820	4340	4680	4940	5015
HTU210 (1/2" Gap – Min Nail) ²	1 ⁵ / ₈	9 ¹ / ₁₆	3 ¹ / ₂	32-16d	14-10dx1 ¹ / ₂	1250	3600	3600	3600	3600	3600	3600
HTU210 (1/2" Gap – Max Nail) ³	1 ⁵ / ₈	9 ¹ / ₁₆	3 ¹ / ₂	32-16d	32-10dx1 ¹ / ₂	3255	4255	4705	5020	5020	5020	5020
Double 2X Sizes												
HTU26-2 (1/2" Gap – Min Nail) ²	3 ⁵ / ₁₆	5 ⁷ / ₁₆	3 ¹ / ₂	20-16d	14-10d	1515	2660	2940	3340	3500	3500	3500
HTU26-2 (1/2" Gap – Max Nail) ³	3 ⁵ / ₁₆	5 ⁷ / ₁₆	3 ¹ / ₂	20-16d	20-10d	1910	2660	2940	3340	3500	3500	3500
HTU28-2 (1/2" Gap – Min Nail) ²	3 ⁵ / ₁₆	7 ¹ / ₁₆	3 ¹ / ₂	26-16d	14-10d	1490	3460	3820	3980	3980	3980	3980
HTU28-2 (1/2" Gap – Max Nail) ³	3 ⁵ / ₁₆	7 ¹ / ₁₆	3 ¹ / ₂	26-16d	26-10d	3035	3460	3820	4340	4680	4940	5555
HTU210-2 (1/2" Gap – Min Nail) ²	3 ⁵ / ₁₆	9 ¹ / ₁₆	3 ¹ / ₂	32-16d	14-10d	1755	4255	4255	4255	4255	4255	4255
HTU210-2 (1/2" Gap – Max Nail) ³	3 ⁵ / ₁₆	9 ¹ / ₁₆	3 ¹ / ₂	32-16d	32-10d	3855	4255	4705	5345	5760	6080	6470

For **SI**: 1 inch = 25.4 mm, 1 pound = 4.45 N.

¹The suffix '(1/2" Gap – Min Heel)' following the model number corresponds to installed conditions where the gap between the supporting member and supported member is more than 1/8 inch (3.2 mm) and less than or equal to 1/2 inch (12.7 mm), and the minimum allowable number of nails, as specified in the table, are driven into the supported wood truss.

²The suffix '(1/2" Gap – Min Nail)' corresponds to installed conditions where the gap between the supporting member and supported member is more than 1/8 inch (3.2 mm) and less than or equal to 1/2 inch (12.7 mm), and the minimum allowable number of nails, as specified in the table above, are driven into the supported wood truss.

³The suffix '(1/2" Gap – Max Nail)' corresponds to installed conditions where the gap between the supporting member and supported member is more than 1/8 inch (3.2 mm) and less than or equal to 1/2 inch (12.7 mm), and the maximum possible number of nails, as specified in the table above, are driven into the supported wood truss.

⁴Refer to Figure 1A for definitions of hanger nomenclature (W, H, B). Refer to Figure 1B for a typical installation detail.

⁵Allowable loads correspond to installations where the maximum possible number of nails are driven into the supporting member. Refer to Section 3.3.3 of this report for nail sizes and required minimum physical properties.

⁶Tabulated allowable loads are for installations in wood members complying with Section 3.3.2 of this report.

⁷Tabulated loads must be selected based on the applicable load duration factor, C_D, as permitted by the applicable building code. See Sections 4.1 and 4.2 for design and installation requirements.

⁸HTU series hangers provide torsional resistance, which is defined as a moment of not less than 75 pounds (334 N) times the depth of the joist at which the lateral movement of the top or bottom of the joist with respect to its vertical position is 0.125 inch (3.2 mm), for joists having a height no greater than the height (H) of the hanger.

⁹Allowable uplift loads have been increased for wind or earthquake loading with no further increase allowed. The tabulated allowable uplift loads must be reduced proportionally when other load durations govern.

TABLE 1B—DIMENSIONS, NAILING SCHEDULES AND DESIGN VALUES FOR HTU SERIES HANGERS
 (1/8 Inch Maximum Gap Between Supporting Member and Supported Member – Maximum Number of Nails into Supporting Member)

MODEL No.	DIMENSIONS ⁴ (inches)			FASTENERS ⁵ (Quantity-Type)		ALLOWABLE LOADS ^{6,7,8} (lbs)						
	W	H	B	Into Supporting Member	Into Supported Member	Uplift ⁹	Download					
						C _D =1.33 or =1.6	C _D =0.9	C _D =1.0	C _D =1.15	C _D =1.25	C _D =1.33	C _D =1.6
Single 2X Sizes												
HTU26 (1/8" Gap – Min Heel) ¹	5/8	7/16	3 1/2	20-16d	11-10dx1 1/2	730	2660	2940	3045	3045	3045	3045
HTU26 (1/8" Gap – Min Nail) ²	5/8	5/16	3 1/2	20-16d	14-10dx1 1/2	1250	2660	2940	3200	3200	3200	3200
HTU26 (1/8" Gap – Max Nail) ³	5/8	5/16	3 1/2	20-16d	20-10dx1 1/2	1555	2660	2940	3340	3600	3800	4010
HTU28 (1/8" Gap – Min Nail) ²	5/8	7/16	3 1/2	26-16d	14-10dx1 1/2	1235	3460	3820	3895	3895	3895	3895
HTU28 (1/8" Gap – Max Nail) ³	5/8	7/16	3 1/2	26-16d	26-10dx1 1/2	2140	3460	3820	4340	4680	4940	5435
HTU210 (1/8" Gap – Min Nail) ²	5/8	9/16	3 1/2	32-16d	14-10dx1 1/2	1330	4255	4355	4355	4355	4355	4355
HTU210 (1/8" Gap – Max Nail) ³	5/8	9/16	3 1/2	32-16d	32-10dx1 1/2	3315	4255	4705	5345	5760	5995	5995
Double 2X Sizes												
HTU26-2 (1/8" Gap – Min Nail) ²	3 5/16	5 7/16	3 1/2	20-16d	14-10d	1515	2660	2940	3340	3600	3800	3910
HTU26-2 (1/8" Gap – Max Nail) ³	3 5/16	5 7/16	3 1/2	20-16d	20-10d	2175	2660	2940	3340	3600	3800	4485
HTU28-2 (1/8" Gap – Min Nail) ²	3 5/16	7 1/16	3 1/2	26-16d	14-10d	1530	3460	3820	4310	4310	4310	4310
HTU28-2 (1/8" Gap – Max Nail) ³	3 5/16	7 1/16	3 1/2	26-16d	26-10d	3485	3460	3820	4340	4680	4940	5850
HTU210-2 (1/8" Gap – Min Nail) ²	3 5/16	9 1/16	3 1/2	32-16d	14-10d	1755	4255	4705	4815	4815	4815	4815
HTU210-2 (1/8" Gap – Max Nail) ³	3 5/16	9 1/16	3 1/2	32-16d	32-10d	4110	4255	4705	5345	5760	6080	7200

For SI: 1 inch = 25.4 mm, 1 pound = 4.45 N.

¹The suffix '(1/8" Gap – Min Heel)' following the model number corresponds to installed conditions where the gap between the supporting member and supported member is 1/8 inch (3.2 mm) or less, and the minimum allowable number of nails, as specified in the table, are driven into the supported wood truss.

²The suffix '(1/8" Gap – Min Nail)' corresponds to installed conditions where the gap between the supporting member and supported wood truss is 1/8 inch (3.2 mm) or less, and the minimum allowable number of nails, as specified in the table above, are driven into the supported wood truss.

³The suffix '(1/8" Gap – Max Nail)' corresponds to installed conditions where the gap between the supporting member and supported wood truss is 1/8 inch (3.2 mm) or less, and the maximum possible number of nails, as specified in table above, are driven into the supported wood truss.

⁴Refer to Figure 1A for definitions of hanger nomenclature (W, H, B). Refer to Figure 1B for a typical installation detail.

⁵Allowable loads correspond to installations where the maximum possible number of nails are driven into the supporting member. Refer to Section 3.3.3 of this report for nail sizes and required minimum physical properties.

⁶Tabulated allowable loads are for installations in wood members complying with Section 3.3.2 of this report.

⁷Tabulated loads must be selected based on the applicable load duration factor, C_D, as permitted by the applicable building code. See Sections 4.1 and 4.2 for design and installation requirements.

⁸HTU series hangers provide torsional resistance, which is defined as a moment of not less than 75 pounds (334 N) times the depth of the joist at which the lateral movement of the top or bottom of the joist with respect to its vertical position is 0.125 inch (3.2 mm), for joists having a height no greater than the height (H) of the hanger.

⁹Allowable uplift loads have been increased for wind or earthquake loading with no further increase allowed. The tabulated allowable uplift loads must be reduced proportionally when other load durations govern.

TABLE 1C—DIMENSIONS, NAILING SCHEDULES AND DESIGN VALUES FOR HTU SERIES HANGERS – ALTERNATE INSTALLATION
(Minimum Number of Nails into Supporting Member)

MODEL No. ¹	DIMENSIONS ² (inches)			FASTENERS ³ (Quantity-Type)		ALLOWABLE LOADS ^{4,5,6,7} (lbs)						
	W	H	B	Into Supporting Member	Into Supported Member	Uplift ⁸	Download					
						C _D =1.33 or =1.6	C _D =0.9	C _D =1.0	C _D =1.15	C _D =1.25	C _D =1.33	C _D =1.6
Single 2X Sizes												
HTU26 (Min)	1 ⁵ / ₈	5 ⁷ / ₁₆	3 ¹ / ₂	10-16d	14-10dx1 ¹ / ₂	925	1330	1470	1670	1800	1900	2040
HTU26 (Max)	1 ⁵ / ₈	5 ⁷ / ₁₆	3 ¹ / ₂	10-16d	20-10dx1 ¹ / ₂	1310	1330	1470	1670	1800	1900	2250
HTU28 (Max)	1 ⁵ / ₈	7 ¹ / ₁₆	3 ¹ / ₂	20-16d	26-10dx1 ¹ / ₂	1920	2660	2940	3340	3600	3800	3905
HTU210 (Max)	1 ⁵ / ₈	9 ¹ / ₁₆	3 ¹ / ₂	20-16d	32-10dx1 ¹ / ₂	2760	2660	2940	3340	3600	3800	3905

For SI: 1 inch = 25.4 mm, 1 pound = 4.45 N.

¹The suffix "(Min)" following the model number corresponds to installed conditions where the minimum allowable number of nails are driven into the supported wood truss. The suffix "(Max)" corresponds to installed conditions where the maximum possible number of nails are driven into the supported wood truss.

²Refer to Figure 1A for definitions of hanger nomenclature (W, H, B). Refer to Figure 1C for an alternate installation detail.

³Allowable loads correspond to installations where the minimum allowable number of nails are driven into the supporting member. Refer to Section 3.3.3 of this report for nail sizes and required minimum physical properties.

⁴Tabulated allowable loads are for installations in wood members complying with Section 3.3.2 of this report.

⁵Tabulated loads must be selected based on the applicable load duration factor, C_D, as permitted by the applicable building code. See Sections 4.1 and 4.2 for design and installation requirements.

⁶Allowable loads are based on a maximum allowable gap of 1/2 inch (12.7) between the supporting member and supported member.

⁷HTU series hangers provide torsional resistance, which is defined as a moment of not less than 75 pounds (334 N) times the depth of the joist at which the lateral movement of the top or bottom of the joist with respect to its vertical position is 0.125 inch (3.2 mm), for joists having a height no greater than the height (H) of the hanger.

⁸Allowable uplift loads have been increased for wind or earthquake loading with no further increase allowed. The tabulated allowable uplift loads must be reduced proportionally when other load durations govern.

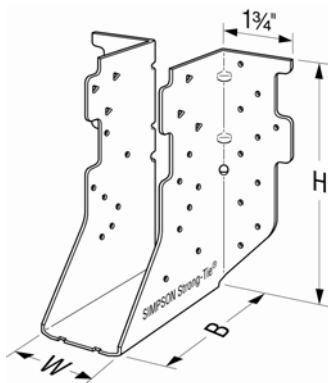

FIGURE 1A—HTU SERIES HANGER

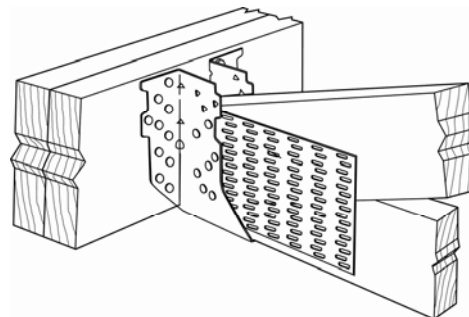

FIGURE 1B—TYPICAL HTU INSTALLATION

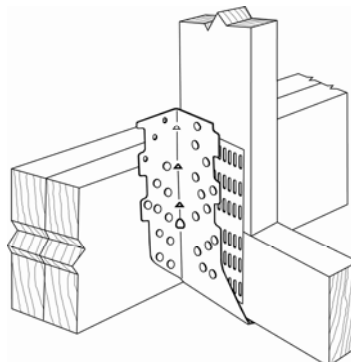

FIGURE 1C—ALTERNATE HTU INSTALLATION

TABLE 2—DIMENSIONS, NAILING SCHEDULES AND DESIGN VALUES FOR LUCZ SERIES HANGERS

MODEL No.	DIMENSIONS (inches)		FASTENERS ¹ (Quantity-Type)		ALLOWABLE LOADS ^{2,3,4,5} (lbs)					
	W	H	Into Supporting Member	Into Supported Member	Uplift ⁶		Download			
					C _D =1.33	C _D =1.60	C _D =0.9	C _D =1.0	C _D =1.15	C _D =1.25
LUC26Z	1 ⁹ / ₁₆	4 ³ / ₄	6 - 10dx1 ¹ / ₂	4 - 10d x 1 ¹ / ₂	615	730	640	710	810	875
			6 - 10d		615	730	640	710	810	875
			6 - 16d		615	730	760	845	965	1040
LUC210Z	1 ⁹ / ₁₆	7 ³ / ₄	10 - 10d x 1 ¹ / ₂	6 - 10d x 1 ¹ / ₂	925	1100	1065	1185	1345	1455
			10 - 10d		925	1100	1065	1185	1345	1455
			10 - 16d		925	1100	1270	1410	1605	1735

For SI: 1 inch = 25.4 mm, 1 pound = 4.45 N.

¹Allowable loads correspond to installations where the maximum possible number of nails is driven into both the supporting member and the supported member. Refer to Section 3.3.3 of this report for nail sizes and required minimum physical properties.

²Tabulated allowable loads are for installations in wood members complying with Section 3.3.2 of this report.

³Tabulated loads must be selected based on the applicable load duration factor, C_D, as permitted by the applicable building code. See Sections 4.1 and 4.2 for design and installation requirements.

⁴The maximum allowable gap between the joist end and the supporting member is 1/8 inch (3.2 mm).

⁵LUCZ series hangers provide torsional resistance, which is defined as a moment of not less than 75 pounds (334 N) times the depth of the joist at which the lateral movement of the top or bottom of the joist with respect to its vertical position is 0.125 inch (3.2 mm), for nominal 2x6 joists supported by the LUC26Z and nominal 2x10 joists supported by the LUC210Z.

⁶Allowable uplift loads have been increased for wind or earthquake loading with no further increase allowed. The tabulated allowable uplift loads must be reduced proportionally when other load durations govern.

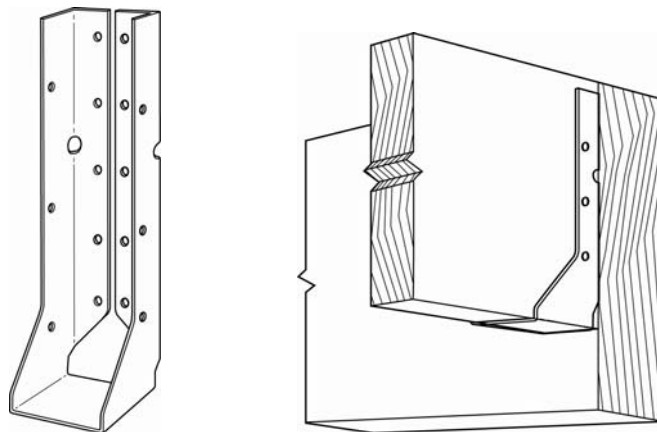

FIGURE 2—LUCZ SERIES HANGER AND INSTALLATION DETAIL