

ICC-ES Evaluation Report

ESR-2236

Reissued January 2025

This report also contains:



- City of LA Supplement

Subject to renewal January 2026

- FL Supplement

ICC-ES Evaluation Reports are not to be construed as representing aesthetics or any other attributes not specifically addressed, nor are they to be construed as an endorsement of the subject of the report or a recommendation for its use. There is no warranty by ICC Evaluation Service, LLC, express or implied, as to any finding or other matter in this report, or as to any product covered by the report.

Copyright © 2025 ICC Evaluation Service, LLC. All rights reserved.

<p>DIVISION: 06 00 00— WOOD, PLASTICS, AND COMPOSITES</p> <p>Section: 06 05 23— Wood, Plastic, and Composite Fastenings</p>	<p>REPORT HOLDER: SIMPSON STRONG-TIE COMPANY INC.</p> 	<p>EVALUATION SUBJECT: SIMPSON STRONG- DRIVE SDS SCREWS</p>	
---	--	--	---

1.0 EVALUATION SCOPE

Compliance with the following codes:

- 2021, 2018, 2015, 2012 and 2009 [International Building Code® \(IBC\)](#)
- 2021, 2018, 2015, 2012 and 2009 [International Residential Code® \(IRC\)](#)

Properties evaluated:

- Structural
- Corrosion Resistance

2.0 USES

The Simpson Strong-Drive SDS screws described in this report are used for steel-to-wood and wood-to-wood connections that are designed in accordance with the IBC. The screws may be used under the IRC where an engineered design is submitted in accordance with IRC Section R301.1.3. Screws having the proprietary Double Barrier Coating may be used where fasteners are required to exhibit corrosion resistance when exposed to adverse environmental conditions and/or in chemically treated wood (subject to the limitations of Sections 4.2, 5.2 and Table 6), and are alternates to hot-dip zinc galvanized fasteners with a coating weight in compliance with [ASTM A153](#), Class D. Screws having the proprietary Double Barrier Coating have been evaluated for use with wood chemically treated with waterborne alkaline copper quaternary, Type D (ACQ-D).

3.0 DESCRIPTION

3.1 General:

The SDS screws are manufactured using a standard cold-forming process, and consist of either heat-treated carbon steel or type 316L stainless steel. The screws have rolled threads, spaced 10 threads per inch (0.393 thread per millimeter), a plain (unslotted) hex washer head, a reamer knurl between the threads and the smooth shank, and either a Type 17 drill (fluted) point or a proprietary four-cut (square-shank) point. The tip length, E, is 0.334 inch (8.5 mm) for the Type 17 drill point and the proprietary four-cut point. The length of threads is approximately equal to two-thirds of the nominal screw length. The screws' major and minor diameters are 0.250 inch and 0.185 inch (6.4 mm and 4.7 mm), respectively, and the unthreaded shank

diameter is 0.242 inch (6.1 mm). Table 1 provides a description of evaluated screws. See [Figure 1](#) for a diagram of the SDS screw.

3.2 Materials:

3.2.1 SDS Screws: The SDS screws are manufactured from [SAE J403](#) low-carbon steel wire, grade 1022; SAE J403 low-carbon-alloy steel wire, grade 10B21, or from type 316L stainless steel wire complying with [ASTM A493](#). The carbon steel screws have either a yellow zinc finish or a proprietary coating that is identified as a Double Barrier Coating. The screws can be supplied with a hot-dipped galvanized (HDG) coating having a minimum average zinc coating thickness of 0.0021 inch (0.053 mm) and a minimum individual zinc coating thickness of 0.0017 inch (0.043 mm) in accordance with ASTM A153, Class D.

3.2.2 Wood Members: Wood members must be either sawn lumber or engineered wood (e.g. LVL, PSL, LSL) having a minimum E value of 0.8E for lateral loading and 1.55E for withdrawal loading. The engineered wood must be addressed in an ICC-ES evaluation report. Applicable assigned specific gravity for sawn lumber and applicable equivalent specific gravity for engineered wood are addressed in Section 4.1.4, Section 4.1.5 and in the footnotes to the tables in this report.

For the purposes of connection design, assigned specific gravity for sawn lumber and for wood structural panels subject to lateral loads must be determined in accordance with Tables 12.3.3A and 12.3.3B, respectively, of the 2018 and [2015 ANSI/AWC](#) National Design Specification (NDS) for Wood Construction (Tables 11.3.3A and 11.3.3B of [NDS-12](#) for the 2012 IBC; Tables 11.3.2A and 11.3.2B of [NDS-05](#) for the 2009 IBC). Sawn lumber members must have a moisture content of less than 19 percent both at time of screw installation, and in service.

For the purposes of connection design, structural glued laminated timber (GL) must have a Specific Gravity for Fastener Design (addressed in Tables 5A through 5D of the NDS Supplement), as indicated in Section 4.1.4, Section 4.1.5 and the tables in this report, as applicable. Unless otherwise noted, GL must have a moisture content of less than 16 percent.

When designing connections with screws installed into the face of cross-laminated timber (CLT) panels fabricated with sawn lumber laminations, all of the laminations must have a minimum assigned specific gravity in accordance with the NDS as indicated in Section 4.1.4, Section 4.1.5 and the tables in this report, as applicable. Moisture content must be less than 16 percent.

For engineered wood, the moisture content at the time of screw installation and in service must be in accordance with the applicable ICC-ES evaluation report on the engineered wood product.

The thickness of the wood main member, t_m , must be equal to or greater than the screw length less the thickness of the side member. For tabulated lateral design values, the tabulated wood side member thickness is an absolute value (not a minimum or maximum value).

3.2.3 Steel Members: For tabulated lateral design values, steel side members must have a minimum tensile strength, F_u , equal to 45 ksi (310.1 MPa) when the steel member design thickness (base-metal thickness exclusive of any coatings) is from 0.0584 inch to 0.1795 inch (1.5 to 4.5 mm), i.e., Nos. 16 gage to 7 gage, and a minimum F_u equal to 52 ksi (358.3 MPa) when the steel member design thickness is 0.2405 inch (6.1 mm), i.e., No. 3 gage. The hole in the steel side member for the SDS screw must be predrilled or prepunched, and must have a standard round hole diameter no greater than 0.273 inch (6.9 mm) in diameter when the steel member thickness is from 0.0584 to 0.1795 inch (1.48 to 4.56 mm), and no greater than 0.305 inch (7.6 mm) in diameter when the steel member thickness is 0.2405 inch (6.1 mm). Hole sizes may deviate from these limitations when the screws are specified in a current evaluation report for use with a specific steel member with larger holes.

4.0 DESIGN AND INSTALLATION

4.1 Design:

The design values in this report are intended to aid the designer in meeting the requirements of IBC Section 1604.2. For connections not completely described in this report, determination of the suitability of the SDS screws for the specific application is the responsibility of the designer and is outside the scope of this report. The designer is responsible for determining the available strengths for the connection, considering all applicable limit states, and for considering serviceability issues.

4.1.1 Screw Strength: Allowable screw shear and tension strengths (ASD) and design screw shear and tension strengths (LRFD) and minimum specified bending yield strength for the screws are shown in [Table 1](#).

4.1.2 Reference Withdrawal Design Values: Reference withdrawal (W) design values for SDS screws must be derived according to provisions for wood screws in the NDS. For purposes of determining NDS tabulated withdrawal design values, the SDS screws are classified as a No. 14 wood screw. The thread lengths for the SDS screws are provided in [Table 1](#) of this report. The reference withdrawal design value in pounds per inch of thread penetration into the face of the main member is shown in [Table 5](#) of this report, for screws installed perpendicular to the face of the member.

4.1.3 Pull-through Design Values: Pull-through design values for wood side members must be determined in accordance with Section 12.2.5 of the 2018 NDS. Pull-over design values for steel side members must be determined in accordance with Section J4.4.2 of AISI S100 (Section E4.4.2 of AISI S100 for the 2015, 2012 and 2009 IBC).

4.1.4 Lateral Steel-to-wood Connections in Accordance with the NDS: The reference lateral design strength for connections of a steel side member and a wood main member using the SDS screws may be designed in accordance with the NDS, subject to the following conditions:

1. The specified bending yield strength from [Table 1](#) must be used for design.
2. The minor thread (root) diameter, D_r , must be used where 'D' is referenced in Tables 12.3.1A, 12.3.1B and 12.3.3 of the NDS (Tables 11.3.1A, 11.3.1B, and 11.3.3 of NDS-12 for the 2012 IBC; Tables 11.3.1A, 11.3.1B and 11.3.2 of NDS-05 for the 2009 IBC).
3. Assigned specific gravity of sawn lumber must be 0.55 or less, in accordance with Table 12.3.3A of the NDS (Table 11.3.3A of NDS-12 for the 2012 IBC, Table 11.3.2A of NDS-05 for the 2009 IBC). Equivalent specific gravity for engineered wood described in Section 3.2.2 must be 0.50 or less.
4. The steel side member must have a design (base-metal) thickness of 0.0584 inch to 0.1795 inch (1.5 to 4.5 mm) [Nos. 16 gage to 7 gage] with a minimum tensile strength, F_u , equal to 45 ksi (310 MPa), or a design (base-metal) thickness of 0.2405 inch (6.1 mm) [No. 3 gage] with a minimum F_u equal to 52 ksi (358 MPa). Hole diameters must comply with Section 3.2.3.
5. The screw penetration into the main wood member must be a minimum of 1.76 inches (45 mm).
6. The dowel bearing length in the main member is the length of screw penetration, less half the tip length ($E/2$), where E is provided in Section 3.1.
7. The dowel bearing strength F_e of the steel member shall be taken as 1.375 times the specified ultimate tensile strength, F_u , of the steel member ($2.2 \cdot F_u / 1.6$).
8. Spacing, edge and end distance in the wood main member must be in accordance with [Table 4B](#), and as needed to prevent splitting of the wood.
9. Edge distance for the steel side member must be a minimum of 0.375 inches (9.5 mm).

4.1.5 Lateral Wood-to-wood Connections in Accordance with the NDS: The reference lateral design strength for connections of two or more wood members using the SDS screws may be designed in accordance with the NDS, subject to the following conditions:

1. The specified bending yield strength from [Table 1](#) must be used for design.
2. The specified minor thread (root) diameter, D_r , must be used where 'D' is referenced in Tables 12.3.1A, 12.3.1B and 12.3.3 of the NDS (Tables 11.3.1A, 11.3.1B, and 11.3.3 of NDS-12 for the 2012 IBC; Tables 11.3.1A, 11.3.1B and 11.3.2 of NDS-05 for the 2009 IBC).
3. Assigned specific gravity of sawn lumber must be 0.55 or less, in accordance with Table 12.3.3A of the NDS (Table 11.3.3A of NDS-12 for the 2012 IBC, Table 11.3.2A of NDS-05 for the 2009 IBC). Equivalent specific gravity for engineered wood described in Section 3.2.2 must be 0.50 or less.
4. The side member thickness must be a minimum of 1.5 inches (38 mm).
5. The screw penetration into the main member must be a minimum of 1.5 inches (38 mm).
6. The dowel bearing length in the main member is the length of screw penetration, less half the tip length ($E/2$), where E is provided in Section 3.1.
7. Spacing, edge and end distance must be in accordance with [Table 4B](#), and as needed to prevent splitting of the wood.

4.1.6 Two-member Steel-to-wood and Wood-to-wood Connections Based on Testing: For select connection configurations, testing has been conducted to determine reference lateral (Z) design values for

SDS screws for single shear steel-to-wood and wood-to-wood connections which exceed those determined in accordance with the NDS. These are shown in [Table 2](#) and [Table 3](#), respectively. Minimum connection geometries for the configurations addressed in [Table 2](#) and [3](#) must be in accordance with [Table 4A](#), or as needed to prevent splitting of wood.

4.1.7 Adjustments to Reference Design Values: Reference design values in this report must be adjusted in accordance with the requirements for dowel-type fasteners in Section 11.3 of the NDS (Section 10.3 of the NDS for the 2012 and 2009 IBC) to determine allowable loads for use with ASD and/or design loads for use with LRFD. The reference design values must also be adjusted in accordance with Section 12.5 of the NDS (Section 11.5 of the NDS for the 2012 and 2009 IBC), as applicable. When the capacity of a connection is controlled by the fastener strength, the allowable connection strength must not be increased by the adjustment factors specified in the NDS.

4.1.8 Capacity Requirements for Wood Members: When designing a connection, the structural members must be checked for load-carrying capacity in accordance with Section 11.1.2 of the [NDS](#) (Section 10.1.2 of NDS-12 and NDS-05 for the 2012 and 2009 IBC), and local stresses within multiple-fastener connections must be checked against Appendix E of the NDS to ensure the capacity of the connection and fastener group.

4.1.9 Connections with Multiple Screws: Connections made with multiple screws must be designed in accordance with Sections 11.2.2 and 12.6 of the NDS (Sections 10.2.2 and 11.6 of NDS-12 and NDS-05 for the 2012 and 2009 IBC).

4.1.10 Combined Loading: Where the screws are subjected to combined lateral and withdrawal loads, connections must be designed in accordance with Section 12.4.1 of the NDS (Section 11.4.1 of NDS-12 and NDS-05 for the 2012 and 2009 IBC).

4.1.11 Design of Metal Parts: Design of connections having steel side members must comply with Section 11.2.3 of the NDS (Section 10.2.3 of NDS-12 and NDS-05 for the 2012 and 2009 IBC)..

4.2 Corrosion Resistance:

The SDS screws with a proprietary Double Barrier Coating may be used in wood treated with waterborne alkaline copper quaternary, Type D (ACQ-D), to a maximum retention level of 0.40 pcf (6.4 kg/m³), or in other treated wood products that have been demonstrated to have lower levels of corrosivity, as alternatives to hot-dip galvanized fasteners prescribed in IBC Section 2304.10.6 (2018 and 2015 IBC Section 2304.10.5; 2012 and 2009 IBC Section 2304.9.5), when subject to the Exposure Conditions shown in [Table 6](#).

The stainless steel SDS screws may be used in the applications described in IBC Section 2304.10.6 (2018 and 2015 IBC Section [2304.10.5](#); 2012 and 2009 IBC Section [2304.9.5](#)) and IRC Section [R317.3](#) where stainless steel fasteners are prescribed.

4.3 Installation:

Installation of the SDS screws must be in accordance with the approved plans, the manufacturer's published installation instructions and this report. The manufacturer's published installation instructions must be available at the jobsite at all times during installation.

SDS screws are installed with a ³/₈-inch (9.5 mm) hex head driver and a low-speed drill. Installation may be performed without predrilling wood members. Edge distances, end distances and spacing of the screws must be as required by [Table 4A](#) for lateral design values shown in [Tables 2](#) and [3](#), or as required for [Table 4B](#) for lateral design values determined in accordance with the NDS. When use is in engineered wood products, the minimum fastener end and edge distances and spacing must be in accordance with [Table 4A](#) or [Table 4B](#) of this report, as applicable, or in accordance with the recommendations of the engineered wood product manufacturer, whichever is more restrictive. The bottom of the screw head must be installed flush to the surface of the member being connected. The screws must not be overdriven.

5.0 CONDITIONS OF USE:

The Simpson Strong-Drive SDS screws described in this report comply with, or are suitable alternatives to what is specified in, those codes listed in [Section 1.0](#) of this report, subject to the following conditions:

- 5.1** The screws must be installed in accordance with the approved plans, the manufacturer's published installation instructions and this report. In the event of a conflict between this report and the manufacturer's published installation instructions, the more restrictive requirements govern.
- 5.2** Calculations and details demonstrating compliance with this report must be submitted to the code official. The calculations and details must be prepared by a registered design professional where required by the statutes of the jurisdiction in which the project is to be constructed.

- 5.3 When the capacity of a connection is controlled by fastener or side plate metal strength, rather than wood strength, the allowable strength of the connection is not permitted to be multiplied by the adjustment factors specified in the NDS.
- 5.4 Use of carbon steel SDS screws in locations exposed to saltwater or saltwater spray is outside the scope of this evaluation report.
- 5.5 Use of carbon steel, yellow zinc coated SDS screws exposed to treated lumber is outside the scope of this report.
- 5.6 The screws are manufactured under a quality control program with inspections by ICC-ES.

6.0 EVIDENCE SUBMITTED

- 6.1 Data in accordance with the [ICC-ES Acceptance Criteria for Dowel-type Threaded Fasteners Used in Wood \(AC233\)](#), dated February 2022.
- 6.2 Data in accordance with the [ICC-ES Acceptance Criteria for Corrosion-resistant Fasteners and Evaluation of Corrosion Effects of Wood Treatments \(AC257\)](#), dated October 2009 (editorially revised January 2021).

7.0 IDENTIFICATION

- 7.1 The ICC-ES mark of conformity, electronic labeling, or the evaluation report number (ICC-ES ESR-2236) along with the name, registered trademark, or registered logo of the report holder [and/or listee] must be included in the product label.
- 7.2 In addition, the packaging for the SDS screws is labeled with the designation “Simpson Strong-Drive SDS,” the Simpson Strong-Tie Co. name and address, the fastener size, point type (four-cut or type 17), coating type (yellow zinc or Double Barrier) and the ICC-ES evaluation report number (ESR-2236). Each screw head is marked with the not-equal-to symbol (\neq), and the letter S followed by a number designating the screw length, as shown in [Table 1](#).
- 7.3 The report holder’s contact information is the following:

SIMPSON STRONG-TIE COMPANY INC.
5956 WEST LAS POSITAS BOULEVARD
PLEASANTON, CALIFORNIA 94588
(800) 999-5099
www.strongtie.com

TABLE 1—SDS SCREW SPECIFICATIONS AND STEEL STRENGTHS

FASTENER DESIGNATION		HEAD MARKING	SCREW SPECIFICATIONS (inches)				SPECIFIED BENDING YIELD STRENGTH ³ , F_{yb} (psi)	ALLOWABLE SCREW STEEL STRENGTH (ASD) ⁴ (lbf)		DESIGN SCREW STEEL STRENGTH (LRFD) (lbf)	
Carbon Steel	Stainless Steel		Screw Length, L_1	Thread Length ¹ , T	Unthreaded Shank Length, $L_1 - T$	Minor Thread (root) Diameter ² , D_r		Tension	Shear	Tension	Shear
SDS25112	SDS25112SS	S1.5	1 1/2	1	1/2	0.185	Carbon Steel: 172,000 Stainless Steel: 164,000	1,430	800	2,145	1,200
SDS25134	—	S1.75	1 3/4	1 1/4	1/2						
SDS25200	SDS25200SS	S2	2	1 1/4	3/4						
SDS25212	SDS25212SS	S2.5	2 1/2	1 1/2	1						
SDS25300	SDS25300SS	S3	3	2	1						
SDS25312	SDS25312SS	S3.5	3 1/2	2 1/4	1 1/4						
SDS25412	—	S4.5	4 1/2	2 3/4	1 3/4						
SDS25500	—	S5	5	2 3/4	2 1/4						
SDS25600	—	S6	6	3 1/4	2 3/4						
SDS25800	—	S8	8	3 1/4	4 3/4						

For S1: 1 inch = 25.4 mm, 1 psi = 6.89 kPa, 1 lbf = 4.45 N.

¹ Length of thread includes tip. See Figure 1.

² Minor thread diameter shown in the table is the nominal diameter with manufacturing tolerances from a minimum of 0.183 inch to a maximum of 0.193 inch.

³ Bending yield strength determined in accordance with [ASTM F1575](#) using the minor thread (root) diameter, D_r .

⁴ Available screw strengths are based on steel properties of the screw. Refer to Section 4.1.4 and [Table 2](#) for reference lateral (Z) design values for steel-to-wood connections. Refer to Section 4.1.5 and [Table 3](#) for reference lateral (Z) design values for wood-to-wood connections.

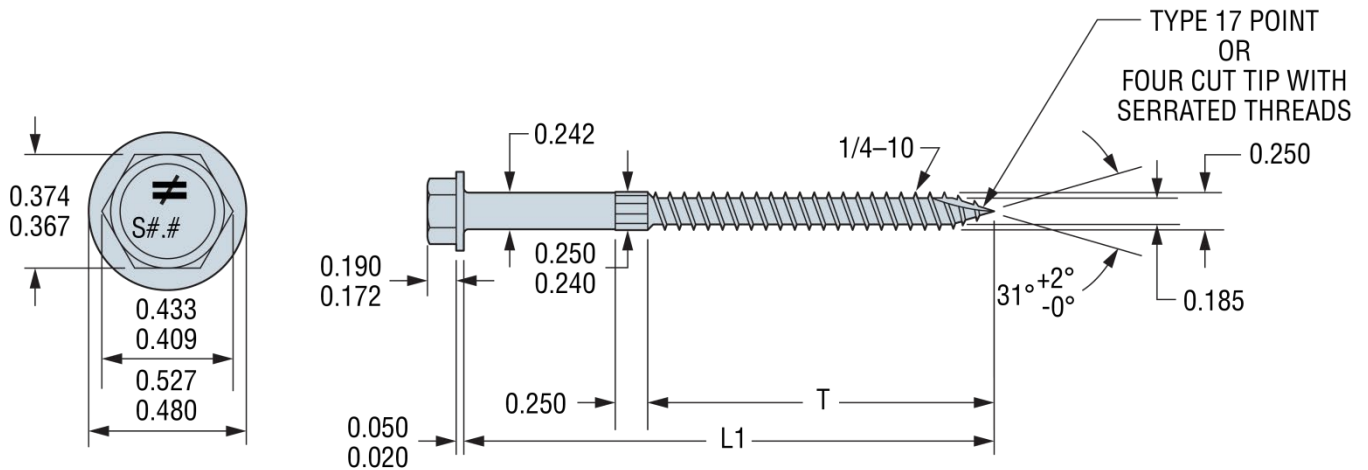

U.S. Patent 6,109,850;
5,897,280; 7,101,133

FIGURE 1—SDS SCREW

TABLE 2—REFERENCE LATERAL DESIGN VALUES (Z) FOR SINGLE SHEAR STEEL-TO-WOOD CONNECTIONS WITH SDS SCREWS^{1,2,5,6,7,8}

SCREW LENGTH (inches)	STEEL SIDE MEMBER DESIGN THICKNESS ^{3, 4} , <i>t_s</i> (inches)					
	0.0584 (No. 16 gage)	0.0721 (No. 14 gage)	0.1026 (No. 12 gage)	0.1342 (No. 10 gage)	0.1795 (No. 7 gage)	0.2405 (No. 3 gage)
	Lateral Design Value (Z) (lbf)					
1½	250	250	250	250	250	250
1¾	250	250	250	250	250	250
2	250	290	290	290	290	290
2½	250	390	390	420	420	420
3	250	420	420	420	420	420
3½	250	420	420	420	420	420
4½	250	420	420	420	420	420
5	250	420	420	420	420	420
6	250	420	420	420	420	420
8	250	420	420	420	420	420

For **SI**: 1 inch = 25.4 mm, 1 lbf = 4.45 N, 1 ksi = 6.89 MPa.

¹The side member must be steel having a minimum tensile strength (*F_u*) equal to 45 ksi when the steel member design thickness is from 0.0584 inch to 0.1795 inch, and a minimum *F_u* equal to 52 ksi when the steel member design thickness is 0.2405 inch.

²The main member must be wood having a minimum assigned specific gravity of 0.50, such as Douglas fir–larch, and must be sufficiently sized to accommodate the screw length less the thickness of the side member. Values are also applicable for fasteners installed into the face of engineered wood described in Section 3.2.2 and having a minimum equivalent specific gravity of 0.50.

³The uncoated minimum steel thickness of the cold-formed product delivered to the jobsite must not be less than 95 percent of the tabulated design thickness, *t_s*.

⁴Holes in the steel side member must be predrilled or prepunched. Hole diameter must comply with Section 3.2.3 of this report.

⁵Tabulated lateral design values (Z) must be multiplied by all applicable adjustment factors included in the NDS for dowel-type fasteners to determine allowable loads for use with ASD and/or design loads for use with LRFD.

⁶Tabulated values are applicable to screws installed perpendicular to the faces of the wood member with the screw axis perpendicular to wood fibers.

⁷Minimum fastener penetration must be equal to the screw length less the thickness of the metal side plate.

⁸See Table 4A for connection geometry requirements.

TABLE 3—REFERENCE LATERAL DESIGN VALUES (Z) FOR SINGLE SHEAR WOOD-TO-WOOD CONNECTIONS WITH SDS SCREWS^{2,3,4,5,6}

SCREW LENGTH (inches)	WOOD SIDE MEMBER ACTUAL THICKNESS ¹ , <i>t_s</i> (inches)	
	1½	1¾
	Lateral Design Value (Z) (lbf)	
2½	190	—
3	280	—
3½	340	340
4½	350	340
5	350	340
6	350	340
8	350	340

For **SI**: 1 inch = 25.4 mm, 1 lbf = 4.45 N.

¹The actual thickness of the wood side member, *t_s*, must be either 1½ or 1¾ inches, as specified in the table. The wood side member thickness is an absolute value, and is not a minimum or maximum value.

²The tabulated lateral design values (Z) are based on wood members having a minimum assigned specific gravity of 0.50, such as Douglas fir–larch. Values are also applicable for fasteners installed into the face of engineered wood described in Section 3.2.2 and having a minimum equivalent specific gravity of 0.50.

³The thickness of the wood main member must be equal to or greater than the screw length less the thickness of the wood side member.

⁴Tabulated lateral design values (Z) must be multiplied by all applicable adjustment factors included in the NDS for dowel-type fasteners to determine allowable loads for use with ASD and/or design loads for use with LRFD.

⁵Screws must be installed into the side grain of the wood members with the screw axis perpendicular to wood fibers.

⁶See Table 4A for connection geometry requirements.

TABLE 4A—CONNECTION GEOMETRY FOR LATERAL CONNECTIONS BASED ON TESTING^{1, 2, 3, 4}

CONDITION	DIRECTION OF LOAD TO GRAIN	ID ⁵	MINIMUM DISTANCE OR SPACING (in.)
Edge distance	Perpendicular	①	1½
	Parallel	①	1
End distance	Perpendicular	②	4
	Parallel	②	3
Spacing Between Fasteners in a Row	Perpendicular	③	3
	Parallel	④	3
Spacing Between Rows of Fasteners	Perpendicular	⑤	3
	Parallel	⑥	3
Spacing Between Staggered Rows	Perpendicular or Parallel	⑦	1½

For SI: 1 inch = 25.4 mm.

¹Tabulated connection geometry values must be used for the reference lateral design values (Z) based on testing, shown in [Table 2](#) and [Table 3](#).

²Edge distances, end distances and spacing of the screws must be sufficient to prevent splitting of the wood, or as required by this table, whichever is the more restrictive.

³Values for spacing between staggered rows apply where screws in adjacent rows are offset by half of the spacing between screws in a row.

⁴For screws which are axially loaded, edge distance, measured in the direction perpendicular to grain, must be a minimum of 1 inch; end distance, measured in the direction of grain, must be a minimum of 2½ inches; the minimum perpendicular to grain spacing between screws must be 1 inch, and the minimum parallel to grain spacing between screws must be 1¾ inches.

⁵See [Figure 2](#) for ID references.

TABLE 4B—CONNECTION GEOMETRY FOR LATERAL CONNECTIONS DESIGNED IN ACCORDANCE WITH THE NDS^{1, 2, 3, 4}

CONDITION	DIRECTION OF LOAD TO GRAIN	ID ⁵	MINIMUM DISTANCE OR SPACING (in.)	
			G < 0.50	G ≥ 0.50
Edge distance	Perpendicular	①	1½	1½
	Parallel	①	1	1
End distance	Perpendicular	②	2½	3¾
	Parallel	②	3	3
Spacing Between Fasteners in a Row	Perpendicular	③	1¼	1¾
	Parallel	④	3	3
Spacing Between Rows of Fasteners	Perpendicular	⑤	2½	2½
	Parallel	⑥	1¼	1¾
Spacing Between Staggered Rows	Perpendicular or Parallel	⑦	5/8	¾

For SI: 1 inch = 25.4 mm.

¹Tabulated connection geometry values are applicable to connections designed in accordance with the NDS.

²Edge distances, end distances and spacing of the screws must be sufficient to prevent splitting of the wood, or as required by this table, whichever is the more restrictive.

³Values for spacing between staggered rows apply where screws in adjacent rows are offset by half of the spacing between screws in a row.

⁴For screws which are axially loaded, edge distance, measured in the direction perpendicular to grain, must be a minimum of 1 inch; end distance, measured in the direction of grain, must be a minimum of 2½ inches; the minimum perpendicular to grain spacing between screws must be 1 inch, and the minimum parallel to grain spacing between screws must be 1¾ inches.

⁵See [Figure 2](#) for ID references.

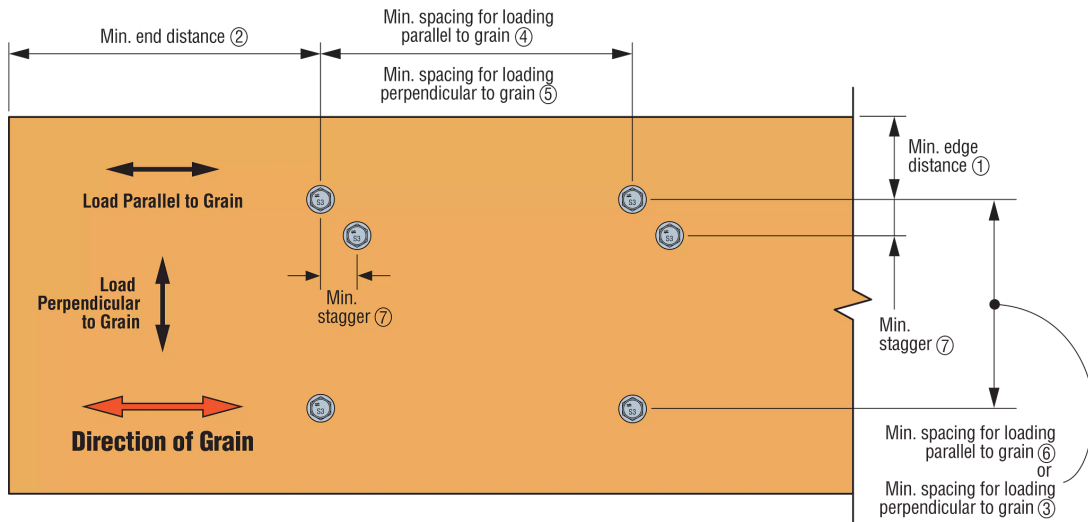

FIGURE 2—SDS CONNECTION GEOMETRY
(Circled numbers refer to information in Tables 4A and 4B)

TABLE 5—REFERENCE WITHDRAWAL DESIGN VALUE FOR SDS SCREWS INSTALLED PERPENDICULAR TO THE FACE OF A WOOD MAIN MEMBER^{1,3}

SDS SCREW DIMENSIONS (in.)		MINIMUM EMBEDDED THREAD LENGTH ² (inches)	REFERENCE WITHDRAWAL DESIGN VALUE, <i>W</i> (lbf/inch)
Screw Length, <i>L</i> 1	Thread Length, <i>T</i>		
1½	1	1	172
1¾	1¼		
2	1¼		
2½	1½		
3	2		
3½	2¼		
4½	2¾		
5	2¾		
6	3¼		
8	3¼		

For **SI**: 1 inch = 25.4 mm, 1 lbf/inch = 175 N/m, 1 lbf = 4.45N.

¹The tabulated reference withdrawal design value must be multiplied by all applicable adjustment factors included in the NDS for dowel-type fasteners to determine allowable loads for use with ASD and/or design loads for use with LRFD.

²Embedded thread length is that portion held in the main member including the screw tip.

³The tabulated withdrawal design value (*W*) is based on wood members having a minimum assigned specific gravity of 0.50, such as Douglas fir–larch. Values are also applicable for fasteners installed into the face of engineered wood described in Section 3.2.2 which have a minimum equivalent specific gravity of 0.50.

TABLE 6— EVALUATED EXPOSURE CONDITIONS FOR SIMPSON STRONG-TIE SDS FASTENERS WITH DOUBLE BARRIER COATING

EXPOSURE CONDITION	TYPICAL APPLICATIONS	USE LIMITATIONS
1	Treated Wood in dry use applications	Limited to use where equilibrium moisture content of the chemically treated wood meets the dry services condition as described in the NDS
3	General construction	Limited to freshwater and chemically treated wood exposure, e.g., no saltwater exposure

DIVISION: 06 00 00—WOOD, PLASTICS AND COMPOSITES
Section: 06 05 23—Wood, Plastic, and Composite Fastenings

REPORT HOLDER:

SIMPSON STRONG-TIE COMPANY INC.

EVALUATION SUBJECT:

SIMPSON STRONG-DRIVE SDS SCREWS

1.0 REPORT PURPOSE AND SCOPE**Purpose:**

The purpose of this evaluation report supplement is to indicate that Simpson Strong-Drive SDS screws, described in ICC-ES evaluation report [ESR-2236](#), have also been evaluated for compliance with the codes noted below as adopted by the Los Angeles Department of Building and Safety (LADBS).

Applicable code editions:

- 2023 *City of Los Angeles Building Code* ([LABC](#))
- 2023 *City of Los Angeles Residential Code* ([LARC](#))

2.0 CONCLUSIONS

The Simpson Strong-Drive SDS screws, described in Sections 2.0 through 7.0 of the evaluation report [ESR-2236](#), comply with LABC Chapter 23, and the LARC, and are subjected to the conditions of use described in this supplement.

3.0 CONDITIONS OF USE

The Simpson Strong-Drive SDS screws described in this evaluation report supplement must comply with all of the following conditions:

- All applicable sections in the evaluation report [ESR-2236](#).
- The design, installation, conditions of use and identification of the Simpson Strong-Drive SDS screws are in accordance with the 2021 *International Building Code*® (2021 IBC) provisions noted in the evaluation report [ESR-2236](#).
- The design, installation and inspection are in accordance with additional requirements of LABC Chapters 16, 17 and 23, as applicable.
- Under the LARC, an engineered design in accordance with LARC Section R301.1.3 must be submitted.

This supplement expires concurrently with the evaluation report, reissued January 2025.

DIVISION: 06 00 00—WOOD, PLASTICS AND COMPOSITES
Section: 06 05 23—Wood, Plastic and Composite Fastenings

REPORT HOLDER:

SIMPSON STRONG-TIE COMPANY INC.

EVALUATION SUBJECT:

SIMPSON STRONG-DRIVE SDS SCREWS

1.0 REPORT PURPOSE AND SCOPE**Purpose:**

The purpose of this evaluation report supplement is to indicate that Simpson Strong-Drive SDS Screws, described in ICC-ES evaluation report ESR-2236, has also been evaluated for compliance with the codes noted below.

Applicable code editions:

- 2023 Florida Building Code—Building
- 2023 Florida Building Code—Residential

2.0 CONCLUSIONS

The Simpson Strong-Drive SDS Screws, described in Sections 2.0 through 7.0 of ICC-ES evaluation report ESR-2236, comply with the *Florida Building Code—Building* and *Florida Building Code—Residential*. The design requirements must be determined in accordance with the *Florida Building Code—Building* or the *Florida Building Code—Residential*, as applicable. The installation requirements noted in ICC-ES evaluation report ESR-2236 for the 2021 *International Building Code*® meet the requirements of the *Florida Building Code—Building* or the *Florida Building Code—Residential*, as applicable.

Use of the Simpson Strong-Drive SDS Screws has also been found to be in compliance with the High-Velocity Hurricane Zone provisions of the *Florida Building Code—Building* and the *Florida Building Code—Residential* with the following condition:

- a) For connections subject to uplift, the connection must be designed for no less than 700 pounds (3114 N).

For products falling under Florida Rule 61G20-3, verification that the report holder's quality assurance program is audited by a quality assurance entity approved by the Florida Building Commission for the type of inspections being conducted is the responsibility of an approved validation entity (or the code official when the report holder does not possess an approval by the Commission).

This supplement expires concurrently with the evaluation report, reissued January 2025.