

ICC-ES Evaluation Report

ESR-2992

Reissued June 1, 2011

This report is subject to renewal in one year.

www.icc-es.org | (800) 423-6587 | (562) 699-0543

A Subsidiary of the International Code Council®

DIVISION: 03 00 00—CONCRETE
Section: 03 15 00—Concrete Accessories
Section: 03 21 00—Reinforcing Steel

REPORT HOLDER:

SIMPSON STRONG-TIE® COMPANY, INC.
 5956 WEST LAS POSITAS BOULEVARD
 PLEASANTON, CALIFORNIA 94588
 (800) 999-5099
www.strongtie.com

EVALUATION SUBJECT:

**SIMPSON STRONG-TIE PUNCHING SHEAR RESISTOR
 RAIL (PSRR)**

1.0 EVALUATION SCOPE
Compliance with the following codes:

- 2009 *International Building Code*® (2009 IBC)
- 2006 *International Building Code*® (2006 IBC)

Property evaluated:

Structural

2.0 USES

The punching shear resistor rails (PSRRs) are used as reinforcement in flat concrete slabs and footings to replace stirrups, drop panels or column capitals to increase the punching shear resistance of slabs and footings.

3.0 DESCRIPTION
3.1 General:

The Simpson Strong-Tie punching shear resistor rail (PSRR) is a stud assembly comprised of punching shear resistor (PSR) studs, which are headed shear studs recognized in an ICC-ES evaluation report, factory-welded to a steel plate. The PSRR stud assembly complies with the requirements in Section 3.5.5 of ACI 318-08 and ASTM A 1044-05. The dimensions of the studs and corresponding plate dimensions are shown in Tables 1 and 2, respectively. Figures 1 and 2 depict the typical PSRR assembly and a typical arrangement in the concrete slab. The number of studs per rail, stud spacing, stud rail assembly height and length, and the distance from the end of the plate to the first stud are determined by the project-specific structural design.

3.2 Material:

3.2.1 Punching Shear Resistor (PSR) Studs: The headed shear studs used in the PSRR assemblies are the

$\frac{3}{8}$ -, $\frac{1}{2}$ -, $\frac{5}{8}$ -, and $\frac{3}{4}$ -inch-shank-diameter (9.5, 12.7, 15.9 and 19.1 mm) PSR studs recognized in an evaluation report and referenced in the approved quality documentation. The PSR studs comply with the material requirements and specifications of ASTM A 1044. The studs are formed from carbon steel complying with ASTM A 29/A 29M, Grades 1010 through 1020, with the following physical properties:

- Minimum yield strength: 51,000 psi (350 MPa)
- Minimum tensile strength: 65,000 psi (450 MPa)
- Minimum elongation: 20 percent in 2 inches (51 mm)
- Minimum reduction of area: 50 percent

Figure 1 shows the stud configuration. The stud dimensions are shown in Table 1.

3.2.2 Flat Steel Base Rails: The flat steel base rails to which the shear studs are welded are formed from carbon steel complying with ASTM A 36 or equivalent, and must be formed from acceptable plate material as set forth in ASTM A 1044 and AWS D.1:2004, Structural Welding Code – Steel, Table 3.1, Groups 1 and 2, with the following physical properties:

- Minimum yield strength: 44,000 psi (303 MPa)
- Minimum tensile strength: 65,000 psi (450 MPa)
- Minimum elongation: 20 percent in 8 inches (203 mm)

Figure 1 and Table 2 provide typical dimensions.

3.3 Stud Welding:

The PSR studs are factory-welded by Simpson Strong-Tie Company to the flat steel rails using welding equipment in accordance with procedures recommended by the PSR manufacturer. All welding complies with AWS D1.1:2004 requirements.

4.0 DESIGN AND INSTALLATION
4.1 Design:

4.1.1 General: Structural design and installation of the Simpson Strong-Tie PSRR punching shear resistor rails used as punching shear reinforcement in reinforced concrete slabs and footing must comply with Sections 7.7.5 and 11.11.5 of ACI 318-08, including the applicable provisions of ACI 318-08 (ACI 318-05 for compliance with the 2006 IBC).

4.1.2 Design Considerations: The structural design must specify the following items, based on the design requirements in this report:

- a. The number of studs in each Simpson Strong-Tie PSRR assembly
- b. Stud spacing(s)
- c. Stud/rail assembly height (OAH)
- d. Stud shank diameter
- e. Distance between column face and the first line of studs (s_o)
- f. Simpson Strong-Tie PSRR assembly length (OAL)

4.1.3 Earthquake-resistant Structures: The stud/rail assembly reinforcement may be used at slab-to-column connections for structures where the flat slab is used together with the primary seismic force-resisting systems in Seismic Design Categories C, D, E and F, such as concrete shear walls, under the following conditions:

4.1.3.1 General: Lateral force-resisting systems of the structure must be designed in accordance with the IBC.

4.1.3.2 Shear Strength: The nominal shear strength provided by the concrete in the presence of the shear studs referenced in Section 11.11.5 of ACI 318-08 must be revised as follows:

$$V_c = 1.5\lambda\sqrt{f'c}b_o d$$

This revision requires revisions to the nominal shear strength, V_n , and the maximum shear stress v_n .

Two-way slabs without beams designated as part of the seismic force-resisting system must comply with the provisions in Section 21.3.6.8 of ACI 318-08, except that V_c is limited as set forth in Section 4.1.3.2 of this report.

Two-way slabs without beams not designated as part of the seismic force-resisting system must comply with the provisions in Section 21.13.6 of ACI 318-08, except that V_c must be limited as set forth in Section 4.1.3.2 of this report and the design story drift ratio must not exceed the drift ratio referenced in Table 12.12-1 of ASCE/SEI 7.

4.2 Installation:

Installation of the Simpson Strong-Tie PSRRs must comply with applicable provisions of the IBC and the approved engineering plans. The Simpson Strong-Tie PSRR assembly must be positioned correctly around the column and set in accordance with the IBC and the approved plans and details. Concrete cover must comply with IBC Section 1907.7. Figure 2 shows the typical installation details.

4.3 Special Inspection:

Continuous special inspection must be provided in accordance with Section 1704.4 of the 2009 and 2006 IBC. The special inspector must verify identification of the Simpson Strong-Tie PSRR assembly and its condition, location, positioning, clearances and concrete cover.

5.0 CONDITIONS OF USE

The Simpson Strong-Tie punching shear resistor rails (PSRRs) described in this report comply with, or are suitable alternatives to what is specified in, those codes listed in Section 1.0 of this report, subject to the following conditions:

- 5.1** The rails must be identified and installed in accordance with this report and the manufacturer's instructions. In the event of a conflict between this report and the manufacturer's instructions, this report governs.
- 5.2** The welded and fabricated shear stud reinforcement plate assemblies must be designed in accordance with Section 4.1 of this report.
- 5.3** Calculations and installation details for each project must be submitted to the code official for approval. This information must be prepared by a registered design professional where required by the statutes of the jurisdiction in which the headed stud assemblies are to be installed.
- 5.4** The design for the finished assemblies must specify the details described in Section 4.1.2.
- 5.5** Installation of the finished assemblies must be in accordance with Section 4.2 of this report.
- 5.6** Special inspection must be provided in accordance with Section 4.3.
- 5.7** The Simpson Strong-Tie Punching Shear Resistor Rail System is fabricated at the Simpson Strong-Tie facility at 5151 South Airport Way, Stockton, California, under a quality control program with third-party inspections by Professional Service Industries (AA-660).

6.0 EVIDENCE SUBMITTED

Data in accordance with the ICC-ES Acceptance Criteria for Headed Shear Stud Reinforcement Assemblies for Concrete Slabs or Footings (AC395), dated November 2008 (editorially revised November 2009).

7.0 IDENTIFICATION

The Simpson Strong-Tie punching shear resistor rail is identified on the packaging by the manufacturer's name (Simpson Strong-Tie Company, Inc.), the evaluation report number (ESR-2992), the name of the inspection agency (Professional Service Industries), the model number and the color code.

TABLE 1—PSRR STUD DIMENSIONS

STUD SHANK DIAMETER (d), inch	HEAD DIAMETER (D), inches	D/d	SHANK AREA (S _A), inch ²	HEAD AREA (H _A), inch ²	H _A / S _A	HEAD THICKNESS (t _i), inch
3/8	1.19	3.17	0.110	1.112	10	0.26
1/2	1.58	3.16	0.196	1.961	10	0.33
5/8	1.98	3.17	0.307	3.079	10	0.40
3/4	2.37	3.16	0.442	4.412	10	0.47

For SI: 1 inch = 25.4 mm; 1 inch² = 645.2 mm².

TABLE 2—SHEAR REINFORCEMENT BASE RAIL DIMENSIONS

STUD DIAMETER (d), inch	WIDTH (b), inches	THICKNESS (t _p), inch	LENGTH
3/8	1.00	0.188	Engineer of record to specify
1/2	1.25	0.250	Engineer of record to specify
5/8	1.75	0.313	Engineer of record to specify
3/4	2.00	0.375	Engineer of record to specify

For SI: 1 inch = 25.4 mm.

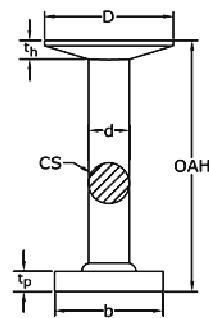

ITEM	DESCRIPTION
D	Head Diameter
t _h	Head Thickness
d	Stud Diameter
CS	Cross Section
OAH	Overall Height
t _p	Plate Thickness
b	Plate Width
S _o	End Spacing
S	Stud Spacing
OAL	Plate Length

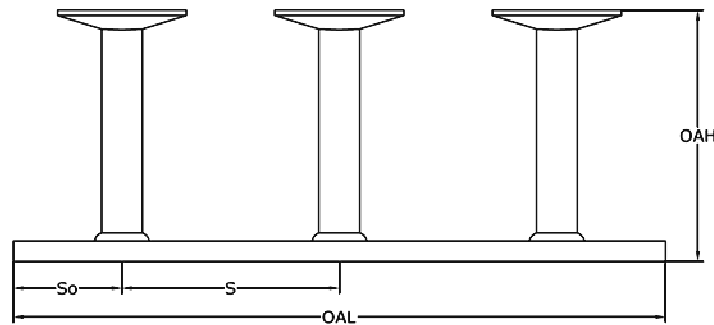

FIGURE 1—TYPICAL PSRR STUD REINFORCEMENT SYSTEM ASSEMBLY

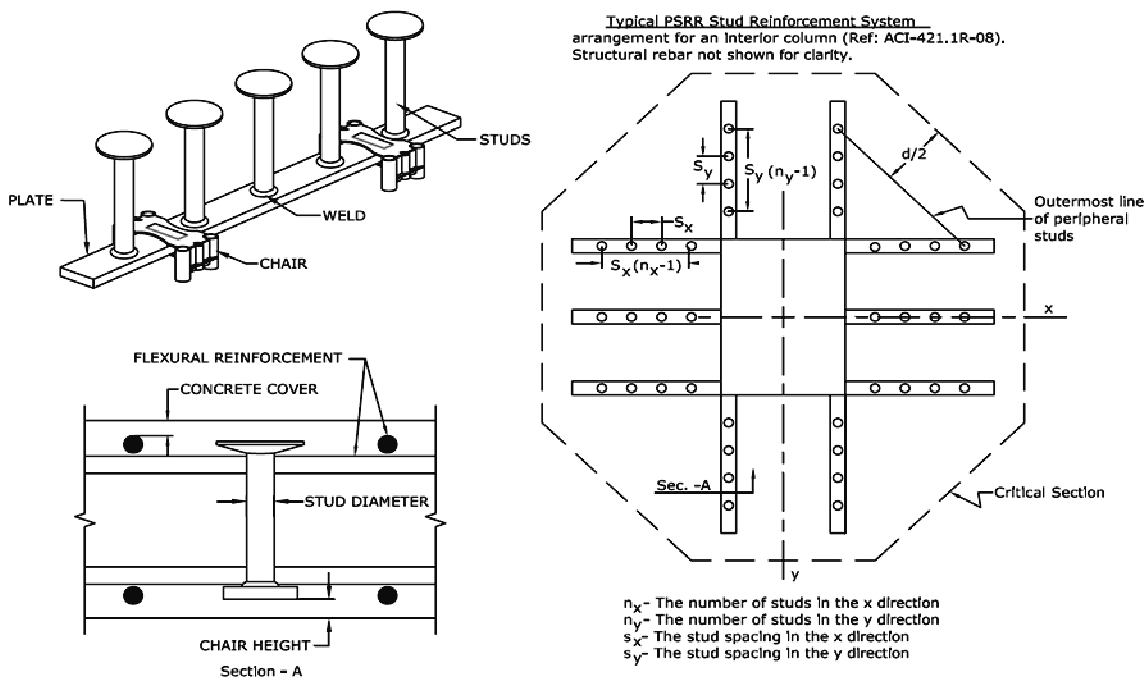

FIGURE 2—TYPICAL PSRR STUD REINFORCEMENT SYSTEM DETAILS