

# ICC-ES Evaluation Report

**ESR-2000**

Issued February 1, 2010

This report is subject to re-examination in one year.

[www.icc-es.org](http://www.icc-es.org) | (800) 423-6587 | (562) 699-0543

A Subsidiary of the International Code Council®

**DIVISION: 07—THERMAL AND MOISTURE PROTECTION**  
**Section: 07240—Exterior Insulation and Finish Systems**
**REPORT HOLDER:**
**COREV AMERICA**  
 11620 BRITTMOORE PARK DRIVE  
 HOUSTON, TEXAS 77041  
 (713) 937-3437  
[www.corev.com](http://www.corev.com)
**EVALUATION SUBJECT:**
**COREV PRECOR AND PRECOR-SB EXTERIOR  
INSULATION AND FINISH SYSTEMS (EIFS)**
**1.0 EVALUATION SCOPE**
**Compliance with the following codes:**

- 2006 *International Building Code*® (IBC)
- 2006 *International Residential Code*® (IRC)

**Properties evaluated:**

- Weather resistance
- Transverse wind load resistance
- Surface-burning characteristics
- Noncombustible construction
- Fire-resistance-rated construction

**2.0 USES**

The COREV PRECOR and PRECOR-SB Exterior Insulation and Finish Systems (EIFS) are used as insulation and exterior wall finish applied to building construction. The PRECOR System may not be used on framed walls of Type V, Groups R1 through R4, Occupancies under the IBC or construction under the IRC. The PRECOR-SB System is used as insulation and exterior wall finish, and to provide water drainage from behind the system on buildings of Type V construction, including Group R Occupancies under the IBC, and on dwellings under the IRC. The PRECOR and PRECOR-SB Systems may be used as part of noncombustible and fire-resistance-rated assemblies when installed in accordance with Sections 4.2.3 and 4.2.4, respectively.

**3.0 DESCRIPTION**
**3.1 General:**

**3.1.1 PRECOR EIFS:** The COREV PRECOR System is a class PB (polymer-based), nonload-bearing EIFS that is installed on substrates of concrete, concrete masonry, unglazed brick or gypsum sheathing over steel framing.

Class PB is an industry designation for an EIFS having a nominal base-coat thickness of between  $\frac{1}{16}$  and  $\frac{1}{4}$  inch (1.59 and 6.35 mm), depending on the number of layers or the thickness of the mesh that is used.

The system components are expanded polystyrene (EPS) foam plastic board, COREV UNIBASE adhesive mixture, treated woven glass fiber mesh, UNIBASE base coat mixture and an acrylic resin finish coat.

**3.1.2 PRECOR-SB EIFS:** The COREV PRECOR-SB System is a class PB, nonload-bearing EIFS with a water-resistive coating that is installed on substrates of concrete, concrete masonry, unglazed brick, wood structural panel sheathing or gypsum sheathing over steel framing. The PRECOR-SB system is the same as the PRECOR except for the addition of the water-resistive coating and drainage components.

The system components are the IMPERCOREV water-resistive coating, COREVNET-DTA joint reinforcing mesh, EPS foam plastic board, COREV UNIBASE adhesive mixture, treated woven glass fiber reinforcing mesh, UNIBASE base coat mixture, an acrylic resin finish coat and weep screed starter tracks.

**3.2 Materials:**
**3.2.1 Substrates:**

**3.2.1.1 Wood Structural Panel Sheathing:** Wood structural panel sheathing may be used only with the PRECOR-SB System and must be Exterior or Exposure 1 grade plywood complying with U.S. DOC PS-1. The sheathing must have a minimum thickness of  $\frac{15}{32}$  inch (11.92 mm).

**3.2.1.2 Gypsum Sheathing:** Gypsum sheathing must comply with ASTM C 79, ASTM C 1177 or ASTM C 1396. The sheathing must have a minimum thickness of  $\frac{1}{2}$  inch (12.7 mm).

**3.2.1.3 Other Substrates:** Substrates of concrete, concrete masonry or unglazed brick must comply with the applicable code.

**3.2.2 PRECOR EIFS:**

**3.2.2.1 Foam Plastic Insulation:** Foam plastic boards must be rigid EPS boards having a nominal density of 1 pcf (16 kg/m<sup>3</sup>) and must comply with the requirements of ASTM C 578, Type I. The boards must have a thickness ranging from  $\frac{3}{4}$  inch [19.1 mm, net after routing or grooving], to 4 inches (102 mm); and a flame-spread rating of 25 or less and a smoke-developed rating not exceeding 450 when tested in accordance with ASTM E 84. The insulation boards must be recognized in an ICC-ES evaluation report as specifically permitted for use with EIFS.

**3.2.2.2 Adhesive:** UNIBASE adhesive mixture is used to adhere the EPS board to the exterior wall substrate surfaces identified in Sections 3.2.1.2 and 3.2.1.3. UNIBASE is a 100 percent acrylic emulsion, containing quartz sand and chemical additives, that is mixed at the jobsite with Type I or Type II portland cement conforming to ASTM C 150, at a one-to-one ratio by weight. For each 64-pound (29.1 kg) pail of unmixed UNIBASE, a maximum of 24 fluid ounces (708 mL) of potable water may be added to adjust the consistency of the mixture. UNIBASE is available in 5-gallon (18.9 L) buckets and has a shelf life of approximately one year if stored in unopened containers in accordance with the manufacturer's recommendations.

**3.2.2.3 Base Coat:** UNIBASE adhesive mixture, described in Section 3.2.2.2, is also used as the base coat for the system.

**3.2.2.4 Reinforcing Mesh:** The reinforcing mesh supplied by COREV for use with the system is open-weave-glass-fiber mesh that is treated for alkali resistance. COREVNET-ST standard mesh has a nominal weight of 4.4 oz/yd<sup>2</sup> (0.15 kg/m<sup>2</sup>) and is the minimum type used to provide reinforcement for the system. Other COREVNET reinforcing meshes with higher nominal weights are also available.

**3.2.2.5 Finish Coat:** COREV acrylic-based textured coatings are used as the finish coat for the system. They consist of a factory-mixed, acrylic co-polymer finish containing silica, quartz and marble aggregate. The finish coat is premixed and available in different textures. The finish coat is intended to be installed over the base coat to protect the base coat from weather exposure. The finish coat is available in 5-gallon (18.9 L) buckets and has a shelf life of approximately one year if stored in unopened containers in accordance with the manufacturer's recommendations.

**3.2.2.6 Sealants:** Sealants must be compatible with the COREV EIFS components and be recommended by Corev America. Evidence must be submitted to the code official showing that the EIFS manufacturer-recommended sealant is a Type S or M, minimum Grade NS, minimum Class 25, and Use O sealant complying with ASTM C 920. Under the Use O classification, the sealant must be qualified for each material to which the sealant will be applied. The details for sealant installation, including the width and thickness of the sealant, must be designed by the registered design professional, designer, builder or Corev America, in that order, to the satisfaction of the code official. Each sealant requires the use of a primer that is used in conjunction with the recommended sealants. The backer rods used in conjunction with the recommended sealants must be closed-cell, extruded polyethylene foam conforming to ASTM C 509, and sized 25 to 33 percent larger than the joint opening.

### 3.2.3 PRECOR-SB EIFS:

**3.2.3.1 Water-resistive Coating:** IMPERCOREV is an acrylic polymer-based water-resistive coating applied directly to the face of the substrate. The product is available in 5-gallon (18.9 L) buckets and has a shelf life of approximately one year, if stored in unopened containers in accordance with the manufacturer's recommendations.

**3.2.3.2 Joint Reinforcing Mesh:** COREVNET-DTA is an adhesively backed glass fiber reinforcing mesh used to tape joints of wood structural panel sheathing or gypsum sheathing before application of IMPERCOREV. It is available in rolls 9 inches (229 mm) wide and 150 feet (3.81 m) long.

**3.2.3.3 Foam Plastic Insulation:** See Section 3.2.2.1.

**3.2.3.4 Adhesives:** UNIBASE adhesive mixture is used to adhere the EPS board to the wood structural panel sheathing after application of the IMPERCOREV on the sheathing. UNIBASE must not be applied directly to the wood sheathing. UNIBASE is described in Section 3.2.2.2.

**3.2.3.5 Base Coat:** See Section 3.2.2.3.

**3.2.3.6 Reinforcing Mesh:** See Section 3.2.2.4.

**3.2.3.7 Finish Coat:** See Section 3.2.2.5.

**3.2.3.8 Sealants:** See Section 3.2.2.6.

**3.2.3.9 Weep Screed Starter Track:** The weep screed starter track is a rigid, exterior-grade, J-shaped PVC molding installed at the base of cladding terminations to drain moisture away from the system. The molding has weep holes for drainage, and must be approved by the manufacturer.

## 4.0 INSTALLATION

### 4.1 General:

Installation of the COREV PRECOR and PRECOR-SB systems must be in accordance with this report, the applicable code and the manufacturer's published installation instructions. The manufacturer's installation instructions must be available at the jobsite at all times during installation.

Steel framing members must be minimum No. 18 gage [0.0428-inch (1.09 mm) base-metal thickness] steel, spaced a maximum of 16 inches (406 mm) on center.

The building substrate to which the EIFS is intended to be installed must be structurally sound and free from foreign material such as paint, wax, dust or oil. A minimum ambient and surface temperature of 40°F (4°C) must be maintained during application and for a minimum of 24 hours after application.

### 4.2 COREV PRECOR:

**4.2.1 Foam Plastic Board and Adhesive:** The COREV UNIBASE adhesive is mixed as described in Section 3.2.2.2. The adhesive is applied to the entire back of the foam plastic board, using a notched stainless steel trowel with notches <sup>3</sup>/<sub>8</sub> inch wide by <sup>1</sup>/<sub>2</sub> inch deep (9.5 mm by 12.7 mm), and spaced no more than 1<sup>1</sup>/<sub>2</sub> inches (38 mm) apart. The notched pattern must run vertically in all cases, so as to create a drainage channel behind the foam plastic board. The foam plastic board must be placed horizontally, in a running bond pattern, onto one of the substrates described in Sections 3.2.1.2 and 3.2.1.3. Firm pressure must be applied to the entire surface, to ensure complete adhesion. Open joints or gaps between boards must be filled with EPS without the use of UNIBASE Adhesive. The minimum thickness of EPS board at any point, including where routed or grooved, must be <sup>3</sup>/<sub>4</sub> inch (19.1 mm). The adhesive must be allowed to cure for 24 hours prior to application of the base coat.

### 4.2.2 Base Coat, Reinforcing Mesh, and Finish Coat:

The EPS board must be sanded or rasped flat before application of the base coat (UNIBASE base coat mixture). The base coat is applied to the exposed surface of the foam plastic board to a minimum thickness of <sup>1</sup>/<sub>16</sub> inch (1.58 mm), using a stainless steel trowel. The reinforcing mesh is applied in a single layer over the entire assembly, and is completely embedded into the wet base coat by troweling from the center to the edges. The reinforcing mesh must be lapped a minimum of 2<sup>1</sup>/<sub>2</sub> inches (63.5 mm) on all sides. The reinforcing mesh must also be wrapped

continuously over corners and doubled at locations such as around openings in the system, at aesthetic and expansion joints, and at corners. Diagonal reinforcement must also be installed at the corner areas of windows and doors.

The finish coat is applied after the base coat is allowed to cure for a period of 24 hours. The coating must be applied uniformly over the cured base coat, by spraying or using a stainless steel trowel, to cover the base coat with a coating that has a nominal thickness of  $1/16$  inch (1.59 mm). The finish coat must be protected from the weather until dry.

Refer to Figures 1 through 12 for assembly and installation details for the PRECOR system.

**4.2.3 Noncombustible Construction:** This section applies to Types I, II, III and IV construction under the IBC. The COREV PRECOR EIFS is permitted to be used on walls required to be of noncombustible construction, where the walls are constructed as noted in Sections 4.2.3.1 through 4.2.3.4.

**4.2.3.1 Interior Finish:** One layer of  $5/8$ -inch-thick (15.9 mm), Type X gypsum wallboard, complying with ASTM C 36 or ASTM C 1396, applied vertically to steel framing with blocked edges. The wallboard must be fastened to framing using minimum  $1 1/4$ -inch-long (32 mm), No. 6, Type S screws, spaced a maximum of 8 inches (203 mm) on center. All board joints must be taped and treated with joint compound. Fastener heads must be covered with joint compound in accordance with ASTM C 840 or GA 216. Floor levels must be blocked with safing insulation.

**4.2.3.2 Steel Framing:** The framing is minimum  $3 5/8$ -inch-deep-by- $1 1/2$ -inch-wide (92 mm by 38 mm), No. 18 gage [0.0428 inch (1.09 mm) base-metal thickness] steel framing, spaced a maximum of 16 inches (406 mm) on center.

**4.2.3.3 Openings:** Openings must be framed with No. 18 gage [0.0428 inch (1.09 mm) base-metal thickness] steel.

**4.2.3.4 Exterior Finish:** One layer of minimum  $1/2$ -inch-thick (12.7 mm) water-resistant core-treated gypsum sheathing, complying with ASTM C 79, ASTM C 1177 or ASTM C 1396, attached to framing using  $1 1/2$ -inch-long (38 mm), No. 8, Type S screws, spaced a maximum of 6 inches (152 mm) on center. The EPS board and the base and finish coats must be applied as described in Sections 4.2.1 and 4.2.2 of this report.

**4.2.4 Fire-resistance-rated Construction:** The COREV PRECOR EIFS may be installed as part of nonload-bearing one- or two-hour fire-resistance-rated wall assemblies, provided the walls are constructed, respectively in accordance with Sections 4.2.4.1 and 4.2.4.2.

**4.2.4.1 One-hour Fire-resistance-rated Nonload-bearing Wall Assembly:**

**4.2.4.1.1 Interior Finish:** The interior finish consists of one layer of  $5/8$ -inch-thick (15.9 mm), Type X gypsum wallboard, complying with ASTM C 36 or ASTM C 1396, vertically applied to steel framing with blocked edges. The wallboard is fastened to framing using minimum  $1 1/4$ -inch-long (32 mm), No. 6, Type S screws, spaced a maximum of 8 inches (203 mm) on center at the perimeter and joints and 12 inches (305 mm) on center in the field of the gypsum board. All board joints must be taped and treated with joint compound, and fastener heads must be covered with joint compound in accordance with ASTM C 840 or GA 216.

**4.2.4.1.2 Steel Framing:** The framing is minimum  $3 5/8$ -inch-deep-by- $1 5/8$ -inch-wide (92 mm by 41 mm), No. 18 gage [0.0428 inch (1.09 mm) base-metal thickness] steel framing, spaced a maximum of 16 inches (406 mm) on center.

**4.2.4.1.3 Exterior Finish:** One layer of minimum  $5/8$ -inch-thick (19.1 mm) water-resistant core-treated gypsum sheathing, complying with ASTM C 79, ASTM C 1177 or ASTM C 1396, attached to framing using  $1 1/4$ -inch-long (32 mm), No. 6, Type S screws, spaced a maximum of 8 inches (203 mm) on center. The EPS board and the base and finish coats are applied as described in Sections 4.2.1 and 4.2.2 of this report, except the minimum thickness of the EPS board must be  $3/4$  inch (19 mm) and the thickness of the base coat must be  $1/8$  inch (3.2 mm).

**4.2.4.2 Two-hour Fire-resistance-rated Nonload-bearing Wall Assembly:**

**4.2.4.2.1 Interior Finish:** The interior finish consists of two layers of  $5/8$ -inch-thick (15.9 mm), Type X gypsum wallboard, complying with ASTM C 36 or ASTM C 1396, applied to steel framing. The first layer of wallboard is fastened to framing using minimum  $1 1/4$ -inch-long (32 mm), No. 6, Type S screws, spaced a maximum of 8 inches (203 mm) on center at the perimeter and joints and 12 inches (305 mm) on center in the field of the gypsum board. The second layer of wallboard is applied perpendicular to the first, and is fastened to framing using minimum  $1 5/8$ -inch-long (41 mm), No. 6, Type S screws, spaced a maximum of 8 inches (203 mm) on center at the perimeter and joints and 12 inches (305 mm) on center in the field of the board. All board joints of the face layer must be taped and treated with joint compound, and fastener heads must be covered with joint compound in accordance with ASTM C 840 or GA 216.

**4.2.4.2.2 Steel Framing:** The framing is minimum  $3 5/8$ -inch-deep-by- $1 5/8$ -inch-wide (92 mm by 41 mm), No. 18 gage [0.0428 inch (1.09 mm) base-metal thickness] steel framing, spaced a maximum of 16 inches (406 mm) on center.

**4.2.4.2.3 Exterior Finish:** The finish consists of two layers of minimum  $5/8$ -inch-thick (19.1 mm), water-resistant core-treated gypsum sheathing, complying with ASTM C 79 or ASTM C 1177. The first layer of gypsum sheathing is fastened to framing using minimum  $1 1/4$ -inch-long (32 mm), No. 6, Type S screws, spaced a maximum of 8 inches (203 mm) on center at the perimeter and joints and 12 inches (305 mm) on center in the field of the gypsum board. The second layer of gypsum sheathing is applied perpendicular to the first, and is fastened to framing using minimum  $1 5/8$ -inch-long (41 mm), No. 6, Type S screws, spaced a maximum of 8 inches (203 mm) on center at the perimeter and joints and 12 inches (305 mm) on center in the field of the board. The EPS board and the base and finish coats are applied as described in Sections 4.2.1 and 4.2.2 of this report, except the minimum thickness of the EPS board must be  $3/4$  inch (19 mm) and the thickness of the base coat must be  $1/8$  inch (3.2 mm).

**4.3 COREV PRECOR-SB:**

The COREV PRECOR-SB System is similar to the COREV PRECOR, except for the addition of the water-resistive coating as described in Section 4.3.1 and the weep screed starter tracks as described in Section 4.3.2. Refer to Figure 13 for installation details for the PRECOR-SB system, showing the water-resistive coating and the weep screed starter track at the base.

**4.3.1 Water-resistive Coating:** COREVNET-DTA mesh is applied at all sheathing joints and at all inside and outside corners. Concrete and masonry substrates do not require use of COREVNET-DTA. Using a  $\frac{3}{4}$ -inch (19 mm) foam nap roller, an even layer of IMPERCOREV is applied over the COREVNET-DTA, covering sheathing joints and corners. COREVNET-DTA must be fully embedded in the IMPERCOREV, ensuring that no mesh color is visible, and that all voids in joints are filled. The IMPERCOREV applied over the joints must be dry to the touch before proceeding.

A minimum 15-mil wet film thickness (10-mil dry film thickness) of IMPERCOREV must be applied over the entire substrate using a  $\frac{3}{4}$ -inch (19 mm) foam nap roller or spray equipment.

**4.3.2 Weep Screed Starter Track:** The weep screed starter track is installed at the base of the wall cladding only. Corrosion-resistant fasteners must be used to secure the track to framing members or to concrete or masonry substrates at a minimum spacing of 16 inches (406 mm) on center. Track ends must be butted, not overlapped. The manufacturer's installation instructions must be followed.

**4.3.3 Foam Plastic Board and Coating Systems:** The EPS board, base and finish coats are applied as described in Sections 4.2.1 and 4.2.2.

**4.3.4 Fire-resistance-rated Construction:** COREV PRECOR-SB EIFS may be installed as part of nonload-bearing one- or two-hour fire-resistance-rated wall assemblies provided the walls are constructed respectively in accordance with Sections 4.2.4.1 and 4.2.4.2, except for the incorporation of the IMPERCOREV, which is roller-applied to the exterior face of the sheathing at a dry film thickness, before the adhesive and EPS insulation are applied.

#### 4.4 Wind Resistance:

The allowable transverse wind pressure for the COREV PRECOR System is 40 psf (1.91 kPa), positive and negative, when installation is in accordance with Sections 4.2.1 and 4.2.2 on substrates of concrete, concrete masonry, unglazed brick or gypsum sheathing over steel framing.

The allowable transverse wind pressure for the COREV PRECOR-SB System is 40 psf (1.91 kPa), positive and negative, when installation is in accordance with Section 4.3 on substrates of concrete, concrete masonry, unglazed brick, gypsum or wood structural panel sheathing over steel framing.

#### 4.5 Special Inspections:

In jurisdictions enforcing the IBC, special inspections in accordance with IBC Sections 1704.1 and 1704.12 are required at the jobsite for the COREV PRECOR and PRECOR-SB Systems applied over framed walls. Duties of the special inspector include verifying field preparation of materials, expiration dates, installation components, curing of components, and installation of joints and sealants.

### 5.0 CONDITIONS OF USE

The COREV PRECOR and PRECOR-SB Exterior Insulation and Finish Systems described in this report comply with, or are suitable alternatives to what is specified in, those codes listed in Section 1.0 of this report, subject to the following conditions:

**5.1** Installation of the COREV PRECOR and PRECOR-SB EIFS must comply with the applicable code, the manufacturer's published installation instructions and this report. The instructions within this report govern if there are any conflicts between the manufacturer's instructions and this report.

**5.2** The COREV PRECOR and PRECOR-SB EIFS must be installed only by authorized applicators approved by Corev America. Installation cards, such as those shown in Figures 14 and 15 of this report, must be posted at the jobsite, and copies must be filed with the code official after installation of the EIFS.

**5.3** Foam plastic insulation must be separated from the interior of the building by an approved thermal barrier in accordance with IBC Section 2603.4.

**5.4** The design wind load pressures must not exceed the allowable wind load pressure as noted in Section 4.4.

**5.5** The COREV PRECOR EIFS may be installed as part of wall assemblies required to be of noncombustible construction, provided the walls are constructed in accordance with Section 4.2.3.

**5.6** The COREV PRECOR EIFS may be installed as part of nonload-bearing one- or two-hour fire-resistance-rated wall assemblies, provided the walls are constructed in accordance with Sections 4.2.4.1 and 4.2.4.2, respectively.

**5.7** The COREV PRECOR-SB EIFS may be installed as part of nonload-bearing one- or two-hour fire-resistance-rated wall assemblies, provided the walls are constructed in accordance with Section 4.3.4 of this report.

**5.8** In areas where the probability of termite infestation is very heavy, in accordance with IBC Section 2603.8 or IRC Section R320.5, foam plastic insulation boards must not be placed on exterior walls within 6 inches (152 mm) of the ground.

**5.9** The systems must not be used as a nailing base to add structural strength to any wall assembly.

### 6.0 EVIDENCE SUBMITTED

**6.1 PRECOR:** Data in accordance with the ICC-ES Acceptance Criteria for Exterior Insulation and Finish Systems (AC219), dated October 2003.

**6.2 PRECOR-SB:** Data in accordance with the ICC-ES Acceptance Criteria for EIFS Clad Drainage Wall Assemblies (AC235), dated October 2004.

**6.3 IMPERCOREV:** Data in accordance with the ICC-ES Acceptance Criteria for Water-resistive Coatings Used as Water-resistive Barriers over Exterior Sheathing (AC212), dated February 2005.

### 7.0 IDENTIFICATION

Each container of the material components of the COREV PRECOR System and the PRECOR-SB System is identified with the Corev America name and address; the product name; the shelf life; the date of manufacture; and the evaluation report number (ESR-2000).

EPS insulation boards are identified in accordance with the applicable evaluation report. In addition, when used on walls required to be of noncombustible construction, each board must be labeled on one edge with the following additional information (which also appears on both faces of one board from each package):

- Inspection agency name.
- Product name (COREV PRECOR or COREV PRECOR-SB) and evaluation report number (ESR-2000).
- Name of the insulation manufacturer and the evaluation report number for the insulation.

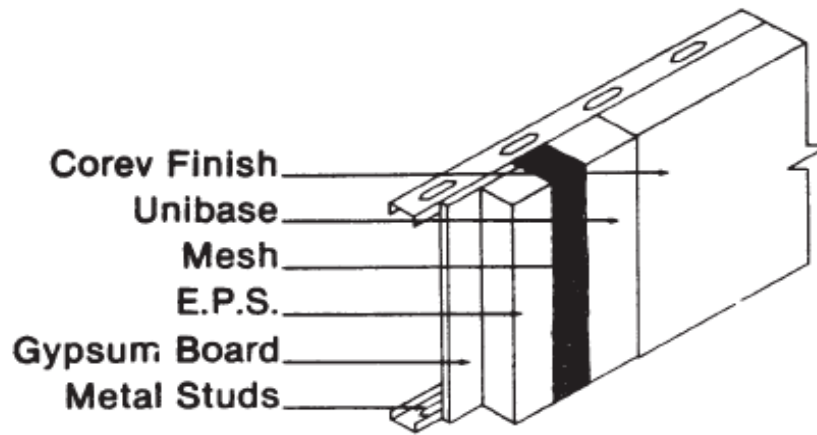

FIGURE 1—PRECOR DETAIL

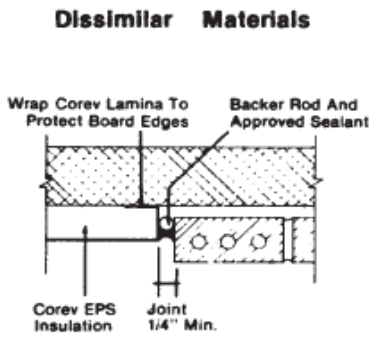

FIGURE 2

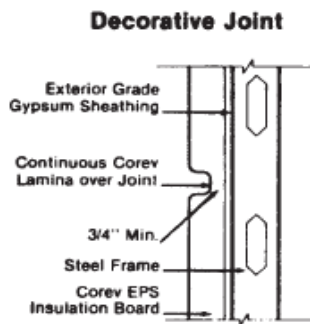

FIGURE 3

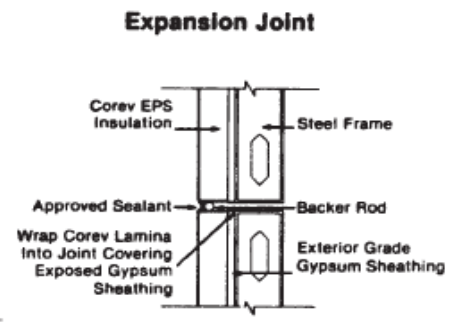

FIGURE 4

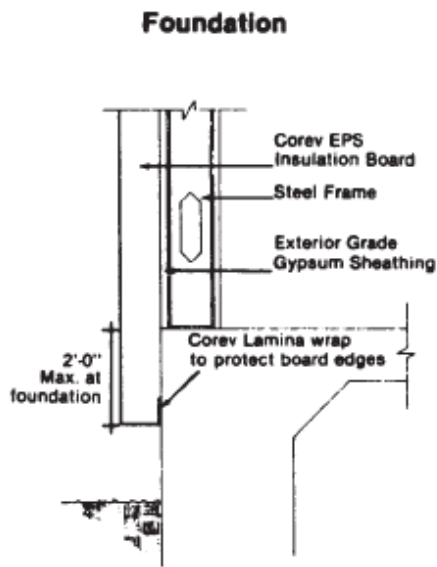

FIGURE 5

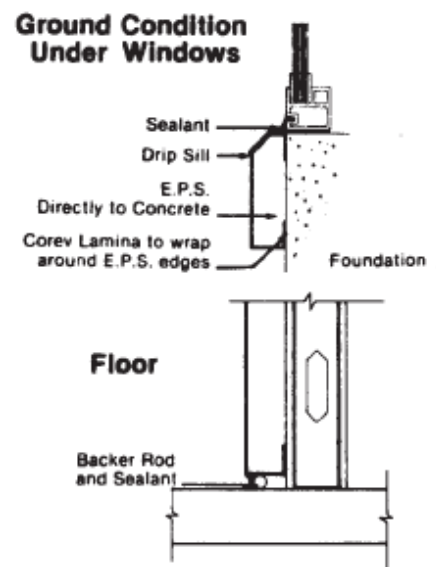

FIGURE 6

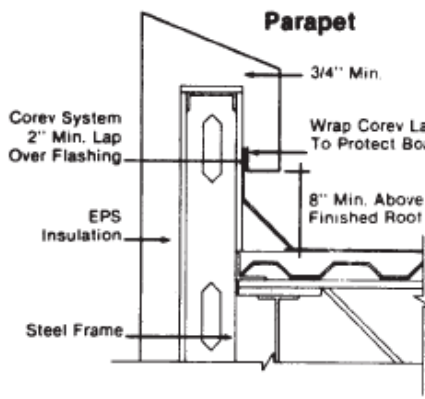

FIGURE 7

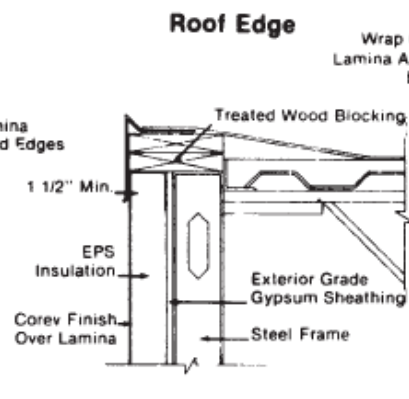

FIGURE 8

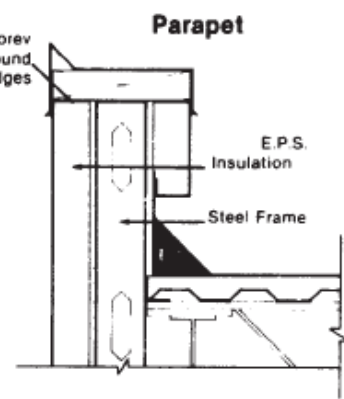

FIGURE 9

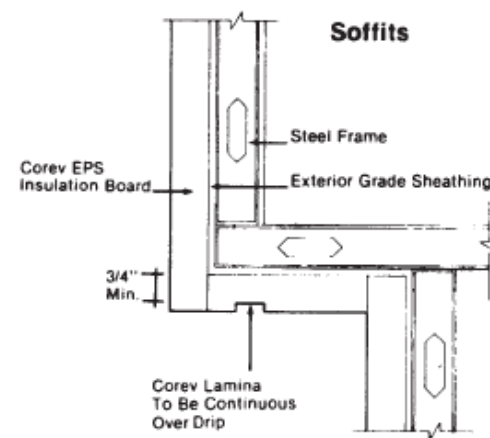

FIGURE 10

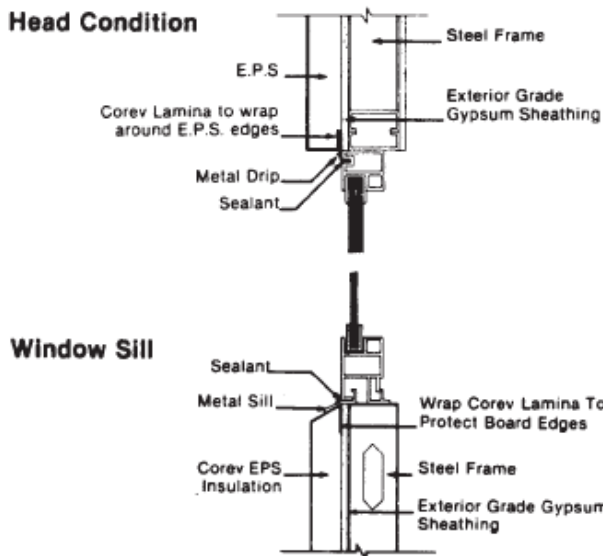

FIGURE 11

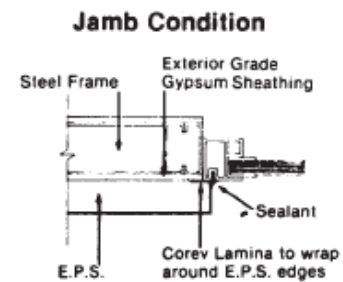
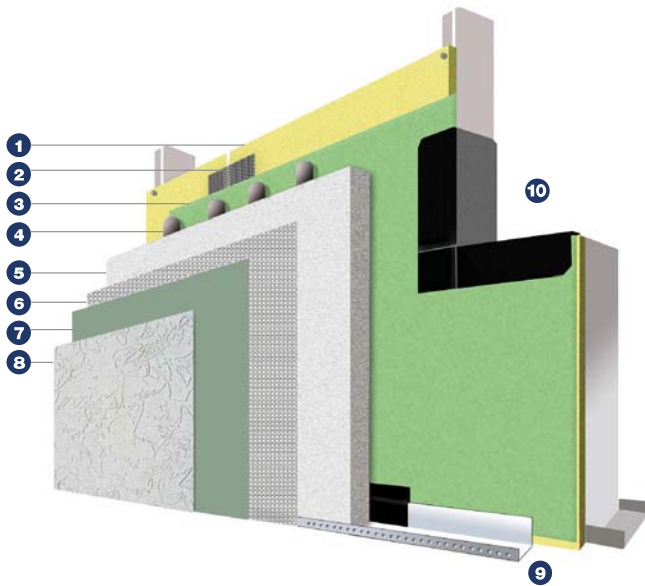
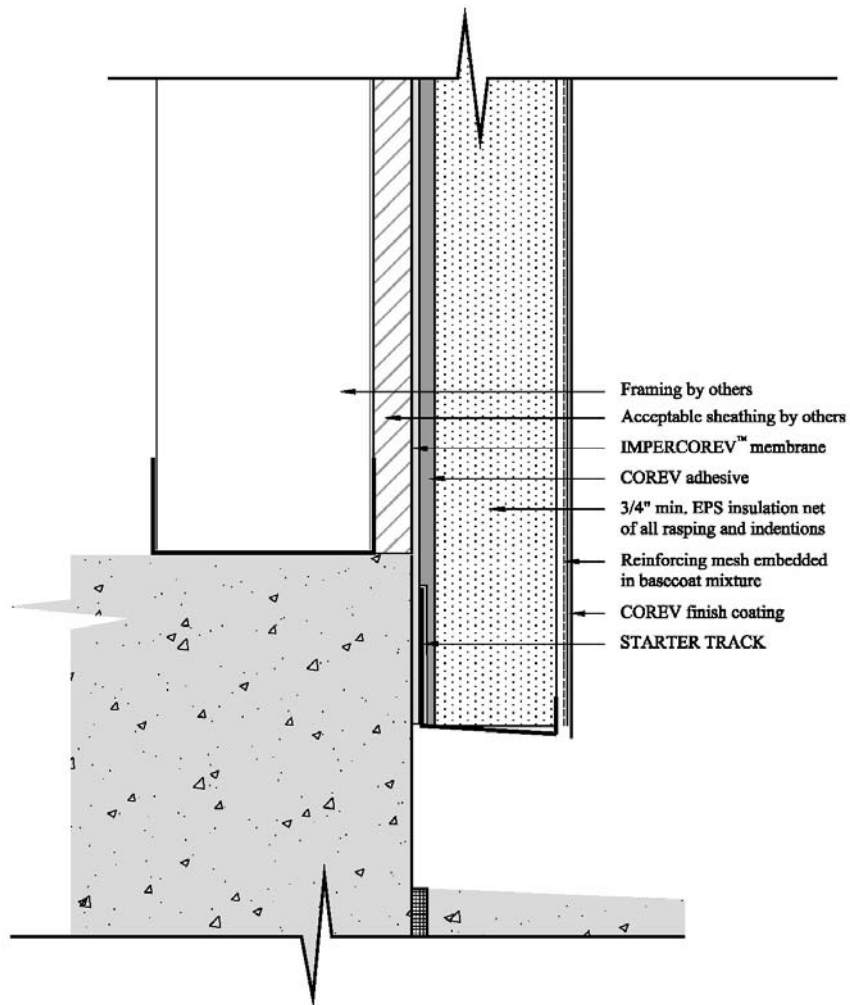

FIGURE 12



1. Approved substrate.
2. COREVNET-DTA™, an adhesively backed reinforcing mesh, is used to tape sheathing joints
3. IMPERCOREV™, an acrylic polymer-based flexible membrane, is applied directly to the face of the approved substrate.
4. UNIBASE™ Adhesive, an acrylic polymer cement modifier mixed at the jobsite with Portland cement, is used to adhere the EPS to approved substrates.
5. EPS Insulation Board
6. COREVNET™ Reinforcing Mesh
7. UNIBASE Basecoat Mixture is an acrylic polymer cement modifier mixed at the jobsite with Portland cement, in which COREVNET Reinforcing Meshes are embedded to create the basecoat lamina.
8. COREV Textured Finish Coatings are premixed acrylic finish coatings available in standard and custom colors.
9. Weep screed starter track.
10. Flashing membrane.

Isometric View



Base Detail

FIGURE 13—PRECOR-SB DETAILS

(EIFS CONTRACTOR NAME)

Completion Date: \_\_\_\_\_

THE EXTERIOR INSULATION AND FINISH SYSTEM (EIFS) INSTALLED ON THE STRUCTURE LOCATED AT THE ADDRESS INDICATED BELOW:

\_\_\_\_ CONFORMS

TO (EIFS MANUFACTURER NAME) RECOMMENDED INSTALLATION PRACTICES AND SECTION (S) \_\_\_\_\_ OF EVALUATION REPORT ER-\_\_\_\_\_.

Address of Structure:

Product Component Names:

\_\_\_\_\_  
\_\_\_\_\_  
\_\_\_\_\_  
\_\_\_\_\_

Adhesive(s) \_\_\_\_\_  
Fasteners (mech) \_\_\_\_\_  
Base Coat \_\_\_\_\_  
Reinforcing Fabric \_\_\_\_\_  
Finish Coat(s) \_\_\_\_\_

INSTALLATION

CONFORMS

- A. Substrate Type and Tolerance \_\_\_\_\_
- B. Weather-resistive Barrier \_\_\_\_\_
- C. EIFS
  - 1. Adhesive and/or Fasteners \_\_\_\_\_
  - 2. Insulation \_\_\_\_\_
  - 3. Reinforcing Fabric \_\_\_\_\_
  - 4. Base Coat \_\_\_\_\_
  - 5. Finish \_\_\_\_\_

D. The information entered above is offered in testimony that the EIFS installation conforms with the EIFS manufacturer's installation methods and procedures, and the EIFS manufacturer's ES report.

NOTE: An installation card shall be received from the Sealant Installer indicating that the sealant installation conforms with the EIFS evaluation report and sealant manufacturer's installation methods and procedures must accompany this declaration.

EIFS Contractor Company Name and Address:

\_\_\_\_\_  
\_\_\_\_\_  
\_\_\_\_\_  
\_\_\_\_\_

Signature of Responsible Officer: \_\_\_\_\_

Typed Name and Title of Officer: \_\_\_\_\_

Telephone Number: (\_\_\_\_) \_\_\_\_\_

cc: \_\_\_\_\_ Original: Building Department (Must be submitted with sealant  
Copy: EIFS Manufacturer installer declaration.)

FIGURE 14—CONTRACTOR INSTALLATION CARD

