

# ICC-ES Evaluation Report

**ESR-2974**

Issued July 1, 2009

*This report is subject to re-examination in one year.*
[www.icc-es.org](http://www.icc-es.org) | (800) 423-6587 | (562) 699-0543

A Subsidiary of the International Code Council®

**DIVISION: 06—WOOD AND PLASTICS**  
**Section: 06170—Prefabricated Structural Wood**

**REPORT HOLDER:**

**SWEET'S JOISTS, INC.**  
 118 BOROVEC ROAD  
 CHEHALIS, WASHINGTON 98532  
 (360) 748-9376  
[www.webjoist.com](http://www.webjoist.com)  
[Bruce@Webjoist.com](mailto:Bruce@Webjoist.com)

**ADDITIONAL LISTEE:**

**WEB JOIST NORTHWEST CORP.**  
 118 BOROVEC ROAD  
 CHEHALIS, WASHINGTON 98532  
 (360) 748-1173

**EVALUATION SUBJECT:**
**WEB-i® WOOD I-JOISTS**
**1.0 EVALUATION SCOPE**
**Compliance with the following codes:**

- 2006 *International Building Code*® (IBC)
- 2006 *International Residential Code*® (IRC)

**Properties evaluated:**

- Structural
- Fire resistance

**2.0 USES**

The WEB-i wood I-joists described in this report are used as structural framing members in floor and roof assemblies. The structural capacities and design provisions of the WEB-i wood I-joists comply with IBC Section 2303.1.2 for allowable stress design, and IRC Section R502.1.4.

**3.0 DESCRIPTION**
**3.1 General:**

The WEB-i joists are prefabricated wood I-joists with lumber flanges and oriented strand board (OSB) webs. The flanges are solid-sawn lumber with glued finger-joints, which are manufactured and tested daily in accordance with the manufacturer's quality control manual, to form continuous flanges. The face grain of the OSB web is oriented vertically, and the web-to-flange and web-to-web connections are proprietary, glued, tongue-and-groove

joists. Joist depths vary from 11<sup>7</sup>/<sub>8</sub> to 28 inches (302 to 711 mm). See Table and Figure 1 for joist descriptions.

**3.2 Materials:**

**3.2.1 Flanges:** Flange material is 1<sup>1</sup>/<sub>2</sub>-by-3<sup>1</sup>/<sub>2</sub>-inch (38 by 89 mm) machine-stress-rated (MSR) lumber meeting the grading rules specified in Table No. 4C of the NDS and in the manufacturer's quality control manual. Lumber species is Douglas fir-larch, hem-fir, spruce-pine-fir, Englemann spruce/lodgepole pine or lodgepole pine.

**3.2.2 Webs:** Webs are <sup>3</sup>/<sub>8</sub>- or <sup>1</sup>/<sub>2</sub>-inch-thick (9.5 or 12.7 mm) OSB panels conforming with Structural I, Exposure I, performance-rated panel requirements as noted in U.S. Department of Commerce Product Standard PS-2 and the manufacturer's quality control manual.

**3.2.3 Adhesive:** The adhesive is an exterior-type adhesive complying with ASTM D 2559 and Section 5.3.3 of ASTM D 5055-08a.

**4.0 DESIGN AND INSTALLATION**
**4.1 Installation:**

Installation of the WEB-i wood I-joists described in this report must comply with the applicable code requirements, this report and manufacturer's published installation instructions. The manufacturer's published installation instructions must be available at the jobsite at all times during installation.

**4.2 Design:**

The WEB-i wood I-joists must be designed using accepted joist design principles and this report.

**4.2.1 Allowable Capacity:** Table 2 specifies allowable moments, shears, and stiffness (EI) for the WEB-i wood I-joists.

**4.2.2 Web Stiffeners:** Both sides of the web of joists that are 16 inches (406 mm) and deeper must have web stiffeners installed at all supports. Table 4 specifies web stiffener requirements. At locations where concentrated loads exceed 1,500 pounds (6.67 kN), both sides of the web require stiffeners for all joist depths. See Figure 2.

**4.2.3 Lateral Support:** The compression flange requires continuous lateral support, and the joist ends require restraint to prevent rollover.

**4.2.4 Holes:** Figure 3 shows allowable hole size and location of holes in the joist webs.

**4.2.5 Duration of Load:** Adjustments for duration of load according to Section 7.3.2 of the NDS apply to the WEB-i wood I-joists and their fastenings.

**4.2.6 In-service Moisture Conditions:** The I-joists must be installed in dry, covered conditions, where the in-service moisture content does not exceed 16 percent.

**4.2.7 Repetitive-member Use:** The repetitive member factor for WEB-i wood I-joists shall be taken as 1.0.

**4.2.8 Beam Span:** Beam span must comply with the code. Vertical shear calculations must include all loads within the span from centerline to centerline of bearing supports.

**4.2.9 Deflection:** Deflection of uniformly loaded, simple-span joists and joists with a concentrated load at mid-span are determined with the deflection formulae in Table 2.

**4.2.10 Blocking Panels:** WEB-i wood I-joists under bearing walls that are perpendicular to the joists must have full-depth solid blocking.

**4.2.11 Bearing Length:** Table 3 provides equations that determine allowable shear based on bearing length of the I-joists at simple-span end supports.

#### **4.3 One-hour Fire-resistance-rated Roof and Floor-ceiling Assemblies:**

WEB-i I-joists used in one-hour fire-resistance-rated roof and floor-ceiling assemblies must be installed in accordance with Section 4.2.2.4 of ESR-1338, or IBC Table 720.1(3) Item Nos. 21-1.1, 23-1.1 and 25-1.1 through 29-1.1.

### **5.0 CONDITIONS OF USE**

The WEB-i wood I-joists described in this report comply with, or are suitable alternatives to what is specified in, those codes listed in Section 1.0 of this report, subject to the following conditions:

**5.1** Installation complies with this report, the manufacturer's published installation instructions and the applicable code. In the event of conflicts between the manufacturer's published installation instructions and this report, this report governs.

**5.2** Structural design information for the use of the joists must be indicated on the construction documents submitted with the permit application. The construction documents and the design configurations must be consistent with this report, and must be prepared by a registered design professional where required by the statutes of the jurisdiction in which the project is to be constructed.

**5.3** Cutting of the flanges of the joists is not permitted. Web openings in wood I-joists must conform to the requirements as specified in Section 4.2.4 of this report. Web opening conditions not covered in Section 4.2.4 of this report are outside the scope of this report.

**5.4** Evaluation of the trusses and joists is limited to interior dry-use conditions. Dry conditions of use are those conditions of use represented by moisture content that is less than 19 percent in the wood I-joists.

**5.5** The joists are manufactured by Web Joist Northwest Corp. in Chehalis, Washington, under a quality control program with inspections by PFS Corporation (AA-652).

### **6.0 EVIDENCE SUBMITTED**

Data in accordance with the ICC-ES Acceptance Criteria for Prefabricated Wood I-joists (AC14), dated October 2007 (editorially revised December 2008).

### **7.0 IDENTIFICATION**

Each WEB-i wood I-joist bears a stamped identification label with the product name (WEB-i Joist), manufacturer's name (Web Joist Northwest Corp.), manufacturer's city and state, evaluation report number (ICC-ES ESR-2974), and name of the inspection agency (PFS Corporation). In addition, the flanges of the I-joists are labeled with the applicable lumber grade stamp.

TABLE 1—WEB-i JOIST DESCRIPTION<sup>1,2,3</sup>

SERIES CODE NUMBER	FLANGE GRADE	WEB THICKNESS (inches)	DEPTH RANGE (Inches)
4212	MSR 1650f-1.5E	$\frac{3}{8}$	11 $\frac{7}{8}$ -24
4312	MSR 1800f-1.6E	$\frac{3}{8}$	11 $\frac{7}{8}$ -24
4412	MSR 2100f-1.8E	$\frac{3}{8}$	11 $\frac{7}{8}$ -24
4512	MSR 2400f-2.0E	$\frac{3}{8}$	11 $\frac{7}{8}$ -24
4612	MSR 2700f-2.2E	$\frac{3}{8}$	11 $\frac{7}{8}$ -24
4712	MSR 2850f-2.3E	$\frac{3}{8}$	11 $\frac{7}{8}$ -24
4232	MSR 1650f-1.5E	$\frac{1}{2}$	16-28
4332	MSR 1800f-1.6E	$\frac{1}{2}$	16-28
4432	MSR 2100f-1.8E	$\frac{1}{2}$	16-28
4532	MSR 2400f-2.0E	$\frac{1}{2}$	16-28
4632	MSR 2700f-2.2E	$\frac{1}{2}$	16-28
4732	MSR 2850f-2.3E	$\frac{1}{2}$	16-28

For SI: 1 in = 25.4 mm.

<sup>1</sup>Flange size is 2x4 (1.50"x3.50").

<sup>2</sup>Web is Structural I OSB.

<sup>3</sup>Series code numbers: 1st digit = Flange size, 2nd digit = Flange grade, 3 digit = Web thickness and 4th digit = Web material.

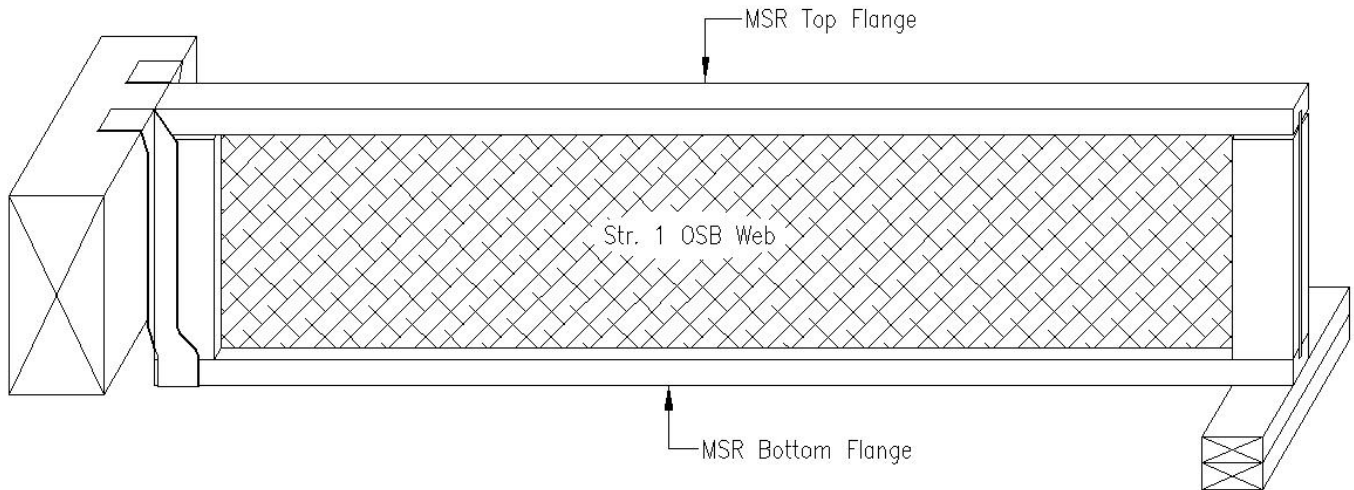
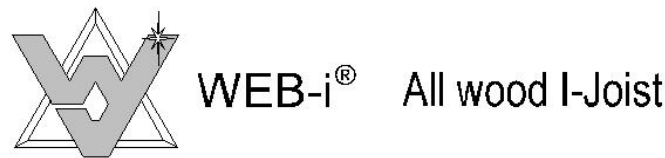

FIGURE 1—WEB-i COMPONENTS

TABLE 2—WEB-I JOIST PROPERTIES<sup>1,2,3,4</sup>

DEPTH (in.)	WEIGHT (plf)	SHEAR (lbs.)	MOMENT (Ft.-lbs.)	EIx10 <sup>6</sup> (lbs.-in. <sup>2</sup> )	Kx10 <sup>6</sup> (lbs.)	DEPTH (in.)	WEIGHT (plf)	SHEAR (lbs.)	MOMENT (Ft.-lbs.)	EIx10 <sup>6</sup> (lbs.-in. <sup>2</sup> )	Kx10 <sup>6</sup> (lbs.)
WEB-i 4212 (2x4 1650f-1.5E Flange & 3/8" OSB Web)						WEB-i 4232 (2x4 1650f-1.5E Flange & 1/2" OSB Web)					
11 7/8	3.6	1,929	4,482	443	5.64	16	4.5	2,995	6,168	899	10.13
14	3.8	2,147	5,398	649	6.65	18	4.8	3,187	7,017	1,180	11.40
16	4.0	2,351	6,259	882	7.60	20	5.1	3,379	7,865	1,504	12.67
18	4.2	2,556	7,120	1,154	8.55	22	5.3	3,572	8,713	1,872	13.93
20	4.4	2,760	7,982	1,466	9.50	24	5.6	3,764	9,561	2,286	15.20
22	4.6	2,965	8,843	1,818	10.45	26	5.9	3,957	10,391	2,747	16.47
24	4.8	3,169	9,704	2,213	11.40	28	6.2	4,149	11,139	3,256	17.73
WEB-i 4312 (2x4 1800f-1.6E Flange & 3/8" OSB Web)						WEB-i 4332 (2x4 1800f-1.6E Flange & 1/2" OSB Web)					
11 7/8	3.6	1,929	5,164	473	5.64	16	4.5	2,995	7,106	959	10.13
14	3.8	2,147	6,218	693	6.65	18	4.8	3,187	8,083	1,259	11.40
16	4.0	2,351	7,210	941	7.60	20	5.1	3,379	9,060	1,604	12.67
18	4.2	2,556	8,202	1,231	8.55	22	5.3	3,572	10,037	1,997	13.93
20	4.4	2,760	9,195	1,563	9.50	24	5.6	3,764	11,014	2,438	15.20
22	4.6	2,965	10,187	1,940	10.45	26	5.9	3,957	11,970	2,930	16.47
24	4.8	3,169	11,179	2,361	11.40	28	6.2	4,149	12,831	3,473	17.73
WEB-i 4412 (2x4 2100f-1.8E Flange & 3/8" OSB Web)						WEB-i 4432 (2x4 2100f-1.8E Flange & 1/2" OSB Web)					
11 7/8	3.6	1,929	6,921	532	5.64	16	4.5	2,995	9,525	1,079	10.13
14	3.8	2,147	8,335	779	6.65	18	4.8	3,187	10,834	1,416	11.40
16	4.0	2,351	9,665	1,059	7.60	20	5.1	3,379	12,144	1,805	12.67
18	4.2	2,556	10,995	1,385	8.55	22	5.3	3,572	13,453	2,246	13.93
20	4.4	2,760	12,325	1,759	9.50	24	5.6	3,764	14,763	2,743	15.20
22	4.6	2,965	13,655	2,182	10.45	26	5.9	3,957	16,045	3,296	16.47
24	4.8	3,169	14,985	2,656	11.40	28	6.2	4,149	17,199	3,908	17.73
WEB-i 4512 (2x4 2400f-2.0E Flange & 3/8" OSB Web)						WEB-i 4532 (2x4 2400f-2.0E Flange & 1/2" OSB Web)					
11 7/8	3.6	1,929	8,459	591	5.64	16	4.5	2,995	11,641	1,199	10.13
14	3.8	2,147	10,187	866	6.65	18	4.8	3,187	13,242	1,574	11.40
16	4.0	2,351	11,812	1,176	7.60	20	5.1	3,379	14,843	2,005	12.67
18	4.2	2,556	13,438	1,539	8.55	22	5.3	3,572	16,443	2,496	13.93
20	4.4	2,760	15,063	1,954	9.50	24	5.6	3,764	18,044	3,048	15.20
22	4.6	2,965	16,689	2,425	10.45	26	5.9	3,957	19,611	3,662	16.47
24	4.8	3,169	18,315	2,951	11.40	28	6.2	4,149	21,021	4,342	17.73
WEB-i 4612 (2x4 2700f-2.2E Flange & 3/8" OSB Web)						WEB-i 4632 (2x4 2700f-2.2E Flange & 1/2" OSB Web)					
11 7/8	3.6	1,929	9,448	650	5.64	16	4.5	2,995	13,002	1,319	10.13
14	3.8	2,147	11,377	952	6.65	18	4.8	3,187	14,790	1,731	11.40
16	4.0	2,351	13,193	1,294	7.60	20	5.1	3,379	16,577	2,206	12.67
18	4.2	2,556	15,008	1,693	8.55	22	5.3	3,572	18,365	2,746	13.93
20	4.4	2,760	16,824	2,150	9.50	24	5.6	3,764	20,153	3,352	15.20
22	4.6	2,965	18,640	2,667	10.45	26	5.9	3,957	21,903	4,028	16.47
24	4.8	3,169	20,455	3,246	11.40	28	6.2	4,149	23,478	4,776	17.73
WEB-i 4712 (2x4 2850f-2.3E Flange & 3/8" OSB Web)						WEB-i 4732 (2x4 2850f-2.3E Flange & 1/2" OSB Web)					
11 7/8	3.6	1,929	10,107	680	5.64	16	4.5	2,995	13,909	1,379	10.13
14	3.8	2,147	12,171	996	6.65	18	4.8	3,187	15,822	1,810	11.40
16	4.0	2,351	14,113	1,353	7.60	20	5.1	3,379	17,734	2,306	12.67
18	4.2	2,556	16,056	1,770	8.55	22	5.3	3,572	19,646	2,870	13.93
20	4.4	2,760	17,998	2,247	9.50	24	5.6	3,764	21,559	3,505	15.20
22	4.6	2,965	19,940	2,788	10.45	26	5.9	3,957	23,431	4,212	16.47
24	4.8	3,169	21,882	3,394	11.40	28	6.2	4,149	25,116	4,993	17.73

For SI: 1 in = 25.4 mm, 1 lbf = 4.448 N, 1 pli = 0.124 kg/m, 1 plf = 1.488 kg/m, 1 ft-lbf = 1.3558 N-m, 1 lbf-in<sup>2</sup> = 292.64 kg-mm<sup>2</sup>.

<sup>1</sup>Calculate bending and shear deflection as follows:

Uniformly distributed load: Defl.(in.) = (5WL<sup>4</sup> / 384EI) + (WL<sup>2</sup> / K)

Concentrated load at centerline: Defl.(in.) = (PL<sup>3</sup> / 48EI) + (2PL / K)

Where: W = Uniform load (pli) L = Span length (in.) EI = MOE times I (pounds-inches<sup>2</sup> x 10<sup>6</sup>)

K = Shear defl. constant (pounds x 10<sup>6</sup>) P = Concentrated load (pounds)

<sup>2</sup>Allowable shear is lower of above value or bearing length value from equations in Table 3.

<sup>3</sup>See Table 4 for web stiffener requirements.

<sup>4</sup>Straight line interpolation may be made between depths.

**TABLE 3—ALLOWABLE SHEAR FOR BEARING LENGTH<sup>1</sup>**

For $\frac{3}{8}$ " Web no Web Stiffeners	$V = 723.4 + 45.876D\sqrt{B}$
For $\frac{3}{8}$ " Web with Web Stiffeners	$V = 1353.8 + 39.672D\sqrt{B}$
For $\frac{1}{2}$ " Web with Web Stiffeners	$V = 1741.8 + 42.812D\sqrt{B}$

For **SI**: 1 in = 25.4 mm, 1 lbf = 4.448 N.

Where:

V = Allowable shear (Lb.)

D = Out to out depth of joist(In.)

B = Bearing length (In.) (B is not to be less than 1.50")

<sup>1</sup>The allowable shear for bearing length is for normal duration of loading and may be increased for duration of loading in accordance with Section 7.3.2 of NDS.

**TABLE 4—WEB STIFFENERS NAILING<sup>1,2,3</sup>**

JOIST DEPTH (inches)	TOTAL NAILS PER STIFFENER LOCATION			
	Simple Span		Continuous Span	
	$\frac{3}{8}$ " Web	$\frac{1}{2}$ " Web	$\frac{3}{8}$ " Web	$\frac{1}{2}$ " Web
$11\frac{7}{8}$	(Box) 3-10d*	(Com.) —	(Box) 4-10d	(Com.) —
14	4-10d*	—	6-10d	—
16	4-10d	4-10d	6-10d	6-10d
18	5-10d	5-10d	7-10d	7-10d
20	6-10d	6-10d	9-10d	9-10d
22	6-10d	6-10d	9-10d	9-10d
24	7-10d	7-10d	10-10d	10-10d
26	—	8-10d	—	12-10d
28	—	8-10d	—	12-10d

For **SI**: 1 in = 25.4 mm.

<sup>1</sup>Web stiffeners are No.2 or better. Use 2x4's at simple spans and 2x6's at continuous spans. Install nails from both sides.

<sup>2</sup>May substitute 14 Ga. staples for 10d Box nail and 13 Ga. staples for 10d Common nail. Staples Min. are  $\frac{7}{16}$ " crown and 3" leg.

<sup>3</sup>Web stiffeners not required for  $11\frac{7}{8}$ " & 14" deep  $\frac{3}{8}$ " web simple span ends but may be needed for bearing length requirements.

\* "U"-type hanger may require web stiffeners to comply with nailing requirements through side plates of hanger.

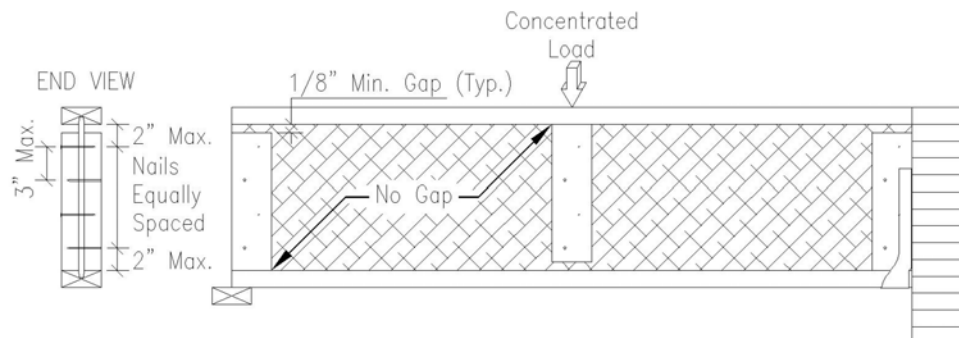

For **SI**: 1 in = 25.4 mm.

**FIGURE 2—WEB STIFFENERS**

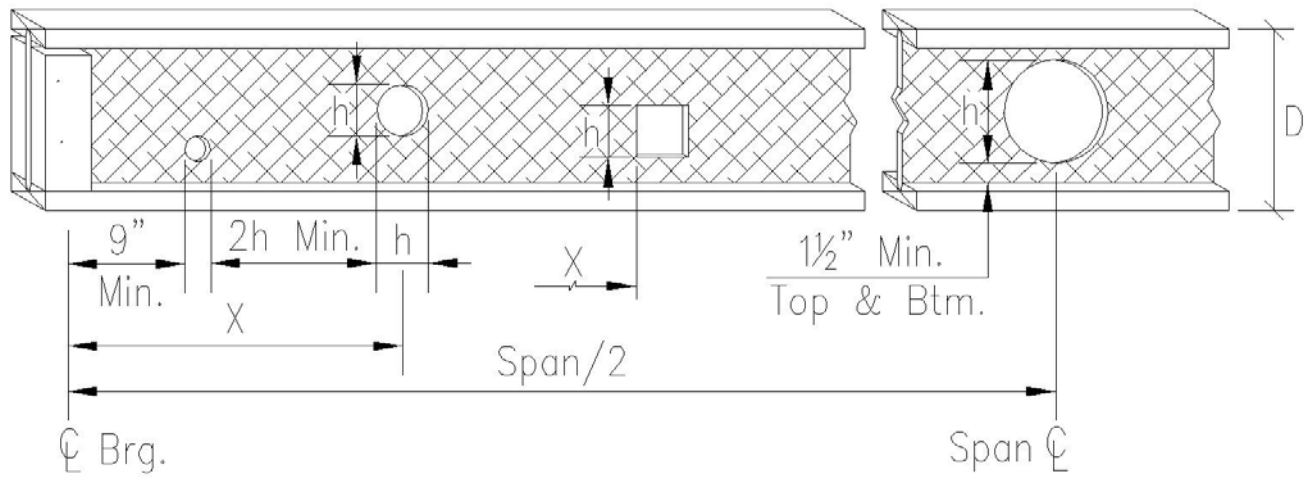

For simple spans and uniform load, the following formulas may be used to determine minimum distance to hole.

$$X = (V - V_H) / W \quad V = WL / 2 \quad V_H = V_A (D_E / D_W)$$

Where:

X = Minimum distance in feet from centerline of support to centerline of round hole or edge of square hole.

V = Shear at bearing in pounds.

W = Uniform loading in pounds per lineal foot.

L = Span in feet; From centerline of support to centerline of support.

V<sub>H</sub> = Allowable shear at hole in pounds.

V<sub>A</sub> = Allowable shear in pounds from Table 8

D<sub>E</sub> = Effective depth at hole in inches (D<sub>E</sub> can not be < 0.5").

@ Round hole ..... D<sub>E</sub> = D<sub>W</sub> - h

@ Square hole ..... D<sub>E</sub> = D<sub>W</sub> - (h/0.75)

@ Rectangular hole D<sub>E</sub> = D<sub>W</sub> - (h/0.6667)

D<sub>W</sub> = Depth of web in inches = D - 1.75"

h = Height of hole in inches (h<sub>max.</sub> to be the lower of D-6" or a value that results in D<sub>E</sub> being ≥ 0.5").

D = Out to out depth of joist in inches.

**NOTES:**

1.) Do not cut the web within nine inches of the support centerline, otherwise a two inch hole can be cut in the web anywhere. The top and bottom flanges are never to be cut.

2.) Where more than one hole is desired, the length of the web between edges of holes must be equal or exceed twice the height of the largest hole.

For SI: 1 in = 25.4 mm, 1 lbf = 4.448 N, 1 lbf/ft = 1.488 kg/m.

**FIGURE 3—HOLE SIZE AND LOCATION**