

ICC-ES Evaluation Report

ESR-1331

Reissued November 1, 2010

This report is subject to re-examination in two years.

www.icc-es.org | (800) 423-6587 | (562) 699-0543

A Subsidiary of the International Code Council®

DIVISION: 06—WOOD AND PLASTICS
Section: 06 05 23—Wood, Plastic, and Composite Fastenings

REPORT HOLDER:

MAINE DECK BRACKET CO.
176 GRANGE AVENUE
MINOT, MAINE 04258
(207) 345-8501

www.deckbracket.com
bracket@megalink.net

EVALUATION SUBJECT:**MAINE DECK BRACKET****1.0 EVALUATION SCOPE****Compliance with the following codes:**

- 2009 and 2006 *International Building Code*® (IBC)
- 2009 and 2006 *International Residential Code*® (IRC)
- BOCA® *National Building Code/1999* (BNBC)

Property evaluated:

Structural

2.0 USES

The Maine Deck Bracket is used to attach an exterior deck or balcony ledger to a solid sawn lumber rim board of an existing or new structure.

3.0 DESCRIPTION

The bracket is manufactured from $\frac{1}{4}$ -inch-thick (6.4 mm) aluminum alloy Grade 6061-T6, complying with ASTM B 221. The bracket is H-shaped and predrilled with four $\frac{9}{16}$ -inch-diameter (14.3 mm) holes on each flange-face. See Figures 1 and 2 for illustrations of the bracket.

4.0 DESIGN AND INSTALLATION**4.1 General:**

Installation of the Maine Deck Bracket shall comply with this report and the manufacturer's published installation instructions. The manufacturer's published installation instructions shall be available at the jobsite at all times during installation.

4.2 Design:

The bracket shall be bolted to the wood framing member (rim board) and to the wood deck header or ledger. Allowable design loads indicated in this report are limited

to the use of $\frac{1}{2}$ -inch-diameter (12.7 mm) hex head bolts and 1-inch-diameter (25.4 mm) washers. The bolts and washers shall be hot-dipped zinc-coated galvanized steel complying with the requirements of ASTM A 307 Grade A or SAE Grade 2 (see Footnote 1 of Table 1). See Table 1 for the maximum allowable design loads per bracket.

Design information provided to the code official shall include the following:

- Number, location and spacing of brackets.
- Maximum design loads anticipated at each bracket, in accordance with the applicable code.
- Allowable loads of the brackets, as specified in this report.
- Size, grade, type, quantity and corrosion protection covering of the bolts used to secure the brackets to the deck and building framing members, consistent with this report.
- Species, grade, size, and specific gravity of the wood members to which the bracket is attached.

4.3 Installation:

Refer to the manufacturer's published installation instructions for installation details. For installation on an existing structure, an area of the exterior wall covering equivalent to the area of the bracket face shall be removed from the framing at the attachment location. Weather protection shall be installed in accordance with IBC Section 1403.2, IRC Section R703.1 or BNBC Section 1404.3.

5.0 CONDITIONS OF USE

The Maine Deck Bracket described in this report complies with, or is a suitable alternative to what is specified in, those codes listed in Section 1.0 of this report, subject to the following conditions:

- 5.1** Installation shall comply with this report, the manufacturer's published installation instructions and the applicable code. In the event of a conflict between the manufacturer's published installation instructions and this report, this report shall govern.
- 5.2** Allowable loads in Table 1 are based on brackets attached to nominally 2-inch-thick-by-6-inch-wide No. 2 southern pine or Douglas fir–larch solid sawn lumber with a specific gravity of 0.50 or greater.
- 5.3** Design loads determined in accordance with the applicable code shall not exceed the allowable loads for the Maine Deck Bracket as set forth in Table 1.

- 5.4 The maximum on-center spacing of the Maine Deck Bracket shall be 8 feet (2428 mm).
- 5.5 Design calculations and details in accordance with Section 4.2 shall be submitted to the code official at the time of permit application. The calculations shall be prepared by a registered design professional where required by the statutes of the jurisdiction in which the project is to be constructed.
- 5.6 The design and construction of the deck supported by the deck bracket and the supporting construction of the deck bracket, including framing members and foundations, are outside the scope of this report and shall comply with the applicable code.
- 5.7 The compatibility of the bracket with preservative-pressure-treated or fire-retardant-treated wood is outside the scope of this report.

- 5.8 Rim joists shall be constructed with continuous fastening and support in accordance with IBC Table 2304.9.1. Details to resist the effects of torsion in the rim joist shall be submitted to the code official.

6.0 EVIDENCE SUBMITTED

Data in accordance with the ICC-ES Acceptance Criteria for Joist Hangers and Similar Devices (AC13), dated October 2006 (editorially revised April 2008).

7.0 IDENTIFICATION

The Maine Deck Bracket described in this report shall be identified with the manufacturer's name (Maine Deck Bracket) and/or trademark, the product name and the evaluation report number (ESR-1331).

TABLE 1—MAXIMUM ALLOWABLE DESIGN CAPACITIES PER BRACKET^{1,2,3,4}

RIM BOARD AND LEDGER THICKNESS (inches)	VERTICAL DOWNLOAD CAPACITY (PARALLEL TO WEB FACE) (lbf)	TORSIONAL CAPACITY (PERPENDICULAR TO THE FLANGE FACE) (in-lbf)	LATERAL CAPACITY (PERPENDICULAR TO WEB FACE) (lbf)
1 ¹ / ₂	1000	390	1115
3	1160	390	1115

For SI: 1 inch = 25.4 mm, 1 lbf = 4.4N, 1 in-lbf = 0.112 N-m.

¹Allowable capacities are based on four 1/2-inch-diameter-by-4 1/2-inch-long hex head bolts through the rim board and four 1/2-inch-diameter-by-3-inch-long hex head bolts through the deck/balcony header complying with ASTM A 307 Grade A or SAE Grade 2, with 1-inch-diameter washers on all wood surfaces. If longer length bolts are required, calculations shall be submitted to the code official to verify compliance with the allowable design loads shown above.

²Capacities shall be multiplied by a factor of 0.4 for wet service in accordance with the NDS.

³Capacities are based on deck joist spacing not exceeding 24 inches (610 mm) on center.

⁴Capacities are limited to No. 2 Southern pine or Douglas fir-larch solid sawn lumber with a specific gravity of 0.50 or greater.

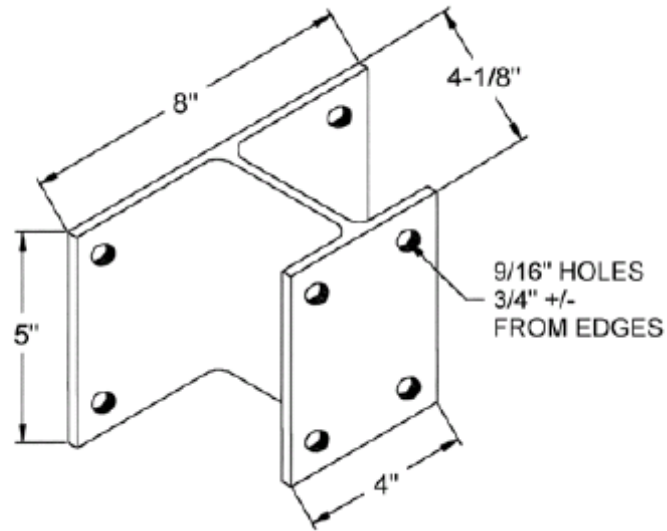

For SI: 1 inch = 25.4 mm.

FIGURE 1—BRACKET DETAIL

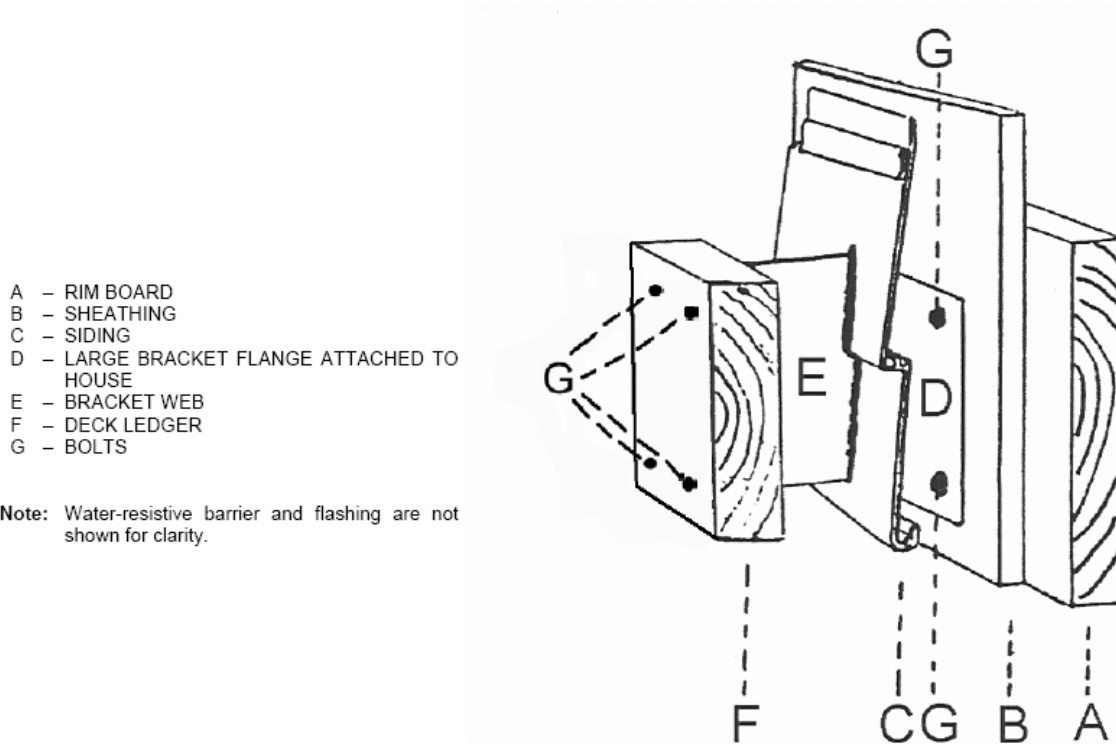

FIGURE 2—INSTALLATION DETAIL