



ICC-ES Evaluation Report

ESR-1236

Reissued August 2022

This report is subject to renewal August 2024.

DIVISION: 07 00 00—THERMAL AND MOISTURE PROTECTION

Section: 07 21 00—Thermal Insulation

REPORT HOLDER:

COVERTECH FLEXIBLE PACKAGING (DIVISION OF BALCAN PLASTICS INC.)

EVALUATION SUBJECT:

rFOIL™ REFLECTIVE PLASTIC CORE INSULATION, AND rFOIL BIG-8™ REFLECTIVE PLASTIC CORE DUCT INSULATION

1.0 EVALUATION SCOPE

Compliance with the following codes:

2.0 DESCRIPTION

rFOIL™ reflective plastic core insulation is manufactured from two layers of polyethylene bubble material laminated on each side with a layer of flat polyethylene film with a metalized surface film. rFOIL™ has a flame-spread index of 25 or less and a smoke-developed index of 450 or less when tested in accordance with ASTM E84 (UL 723). In this configuration, the water vapor permeance of the insulation is less than 1.0 perm when tested in accordance with ASTM E96.

rFOIL Big-8™ reflective plastic core duct insulation is manufactured from two layers of the rFOIL™ reflective plastic core insulation separated by 2-inch-wide strips of bubble pack insulation (see Figure 4 of this report). rFOIL Big-8™ has a flame-spread index of 25 or less and a smoke-developed index of 50 or less when tested in accordance with ASTM E84 (UL 723). In this configuration, the water vapor permeance of the insulation is less than 0.05 perm when tested in accordance with ASTM E96.

3.0 INSTALLATION

3.1 rFOIL™ Reflective Plastic Core Insulation Installation:

3.1.1 General: The insulation is stapled to wood studs, floor joists or furring with 5/16-inch-crown-width (7.9 mm) staples having a minimum leg length of 1/4 inch (6.35 mm), spaced at 6 inches (152 mm) on center. Seams or tears shall be patched with aluminum foil adhesive tape supplied by Covertech Fabricating, Inc.

The manufacturer's published installation instructions and this report must be strictly adhered to and a copy of these instructions must be available at all times on the jobsite during installation. The instructions within this report govern if there are any conflicts between the manufacturer's published instructions and this report.

3.1.2 Thermal Resistant Assemblies:

3.1.2.1 Wall Cavity Application: rFOIL™ insulation is placed on the inside of the stud cavity and stapled at the midpoint of the 3 1/2-inch (89 mm) side of 2-by-4 wood studs spaced at 16 inches (406 mm) on center. The insulation forms two 1 5/8-inch-deep (41.3 mm) air spaces within the cavity. The exterior surface is covered with 1/2-inch-thick (12.7 mm) plywood, complying with and attached in accordance with the applicable code. The interior surface is covered with minimum 1/2-inch-thick (12.7 mm) gypsum wallboard complying with ASTM C1396, attached in accordance with the applicable code. Inside surface-to-surface thermal resistance of the assembly is noted in Table 1 of this report. Thermal resistance of the insulated cavity described in this section is noted in Table 2 of this report. See Figure 1 of this report for an illustration of the assembly.

3.1.2.2 Crawl Space Application: The floor assembly consists of minimum of 2-by-8 wood floor joists spaced a maximum of 24 inches (610 mm) on center, with a minimum of one layer of 3/4-inch-thick (19 mm) plywood on the upper surface, attached in accordance with the applicable code. The length of the insulation sheet is placed parallel to the floor joists. Inside surface-to-surface thermal resistance of the assembly is noted in Table 1 of this report. See Figure 2 of this report for an illustration of the assembly.

3.1.2.3 Furring Strip Block Wall Application: The block wall assembly consists of nominal 1-by-2 furring strips attached vertically at a maximum of 16 inches (406 mm) on center to minimum 8-inch-thick (203 mm) block wall. The insulation is installed parallel to the furring strips using fasteners noted in Section 4.1 of this report. A second layer of 1-by-2 furring strips is placed over the insulation and directly over the existing furring strips using 1 1/4-inch-long (38 mm) nails. Minimum 1/2-inch-thick (12.7 mm) gypsum wallboard complying with ASTM C1396 is attached over the furring strips in accordance with the applicable code to create two 3/4-inch (19 mm) air spaces. Inside surface-to-surface thermal resistance of the assembly is noted in Table 1 of this report. See Figure 3 of this report for an illustration of the assembly.

3.2 rFOIL Big-8™ Duct Insulation Application:

The rFOIL Big-8™ reflective plastic core duct insulation is installed using one of the following methods:

- a. To achieve the thermal resistance value (*R*-value) listed in Table 3, 2-inch-wide spacer strips of rFOIL™ reflective plastic core duct insulation are wrapped around the duct to create spacers at 2-foot intervals. The Big-8 duct insulation is wrapped around the duct with the spacers creating an airspace between the duct and the insulation. All seams and joints are sealed using rFOIL Metalized Tape (see Figure 5 of this report).
- b. To achieve the thermal resistance value (*R*-value) listed in Table 3, the Big-8 duct insulation is wrapped loosely around the duct without the spacers used in method (a). All seams and joints are sealed using rFOIL Metalized Tape (see Figure 6 of this report).

4.0 CONDITIONS OF USE

The rFOIL™ reflective plastic core insulation and Big-8 reflective plastic core duct insulation described in this report complies with, or is a suitable alternative to what is specified in, those codes listed in Section 1.0 of this report, subject to the condition that installation complies with this report, the manufacturer’s published installation instructions and the applicable code.

- 4.1 The rFOIL Big-8™ reflective plastic core duct insulation must be installed in accordance with the applicable requirements of Chapter 6 of the IMC.
- 4.2 Air ducts operating at temperatures exceeding 120°F (49°C) must be provided with sufficient thermal

insulation to limit the exposed surface temperature to 120°F (49°C).

5.0 EVIDENCE SUBMITTED

Data and reports of tests in accordance with the ICC-ES Acceptance Criteria for Reflective Insulation (AC02), dated June 2011 (Editorially revised March 2018).

6.0 IDENTIFICATION

- 6.1 Each roll of product is labeled with the manufacturer’s name (Covertech Flexible Packaging (Division of Balcan Plastics Inc.)); product name (rFOIL); surface-burning characteristics; thermal resistance (*R*-value) for rFOIL Big-8™; the wording “See ESR-1236 for the thermal resistance (*R*-value) of the assembly or assemblies”; the lot number; product dimensions; and the evaluation report number (ESR-1236).
- 6.2 The report holder’s contact information is the following:

**COVERTECH FLEXIBLE PACKAGING
(DIVISION OF BALCAN PLASTICS INC.)
279 HUMBERLINE DRIVE
ETOBICOKE, ONTARIO M9W 5T6
CANADA
(416) 798-1340
www.rfoil.com
info@covertechflex.com**

TABLE 1—INSIDE SURFACE-TO-SURFACE THERMAL RESISTANCE (*R*-value) OF rFOIL™ INSULATION IN VARIOUS ASSEMBLIES¹

ASSEMBLY AND INSULATION	THERMAL RESISTANCE (<i>R</i> -VALUE) (hr. ft. ² °F/Btu)	REFER TO
Wall cavity—horizontal heat flow	6.36	Figure 1
Crawl space: Heat flow up	5.14	Figure 2
Heat flow down	9.05	Figure 2
Block wall—horizontal heat flow	7.67	Figure 3

For SI: 1 inch = 25.4 mm, 1 hr. ft.² °F/Btu = 0.176 m² K/W.

¹*R*-values shown include the contribution from the insulation, air space and studs (or joists) only.

TABLE 2—THERMAL RESISTANCE (R-VALUE) (hr. ft.² °F/Btu) OF CAVITIES INSULATED WITH rFOIL^{1,2}

HEAT FLOW UP	HEAT FLOW DOWN	HORIZONTAL HEAT FLOW
5.30	10.57	6.83

For SI: 1 inch = 25.4 mm, 1 hr. ft.² °F/Btu = 0.176 m² K/W.

¹Framing is 2-by-4 wood studs spaced 16 inches on center. Insulation is installed as described in Section 4.2.

²R-values shown include the contribution from the insulation and air space only.

TABLE 3—R-VALUES FOR rFOIL™ INSULATED METAL AIR DUCT ASSEMBLIES

MODEL NUMBER	FIGURE NUMBER	R-VALUE ¹ (hr·ft ² ·°F/Btu)	R-VALUE ² (hr·ft ² ·°F/Btu) including air film resistance
rFOIL™ Big 8 Spacer Wrap	5	6.4	8.0
rFOIL™ Big 8 Direct Wrap	6	5.9	6.7

For SI: 1 hr.·ft.²·°F/Btu = 0.176 m²·K/W.

¹R-values are according to ASTM C335, when tested at a mean temperature of 75°F (23.9°C), for outside surface of the duct to the outside surface of insulation.

²R-values are according to ASTM C335, when tested at a mean temperature of 75°F (23.9°C), for outside surface of the duct to the outside surface of insulation including the air film resistance.

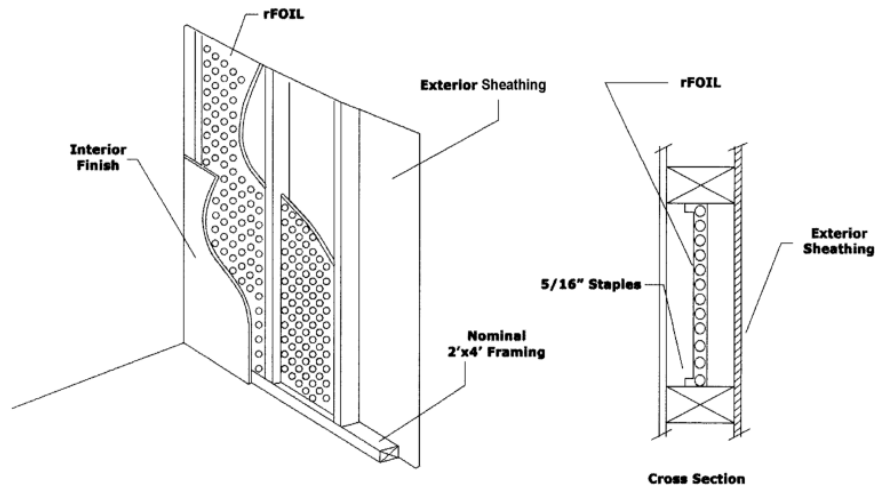

FIGURE 1—WALL CAVITY APPLICATION
SI: 1 inch = 25.4 mm

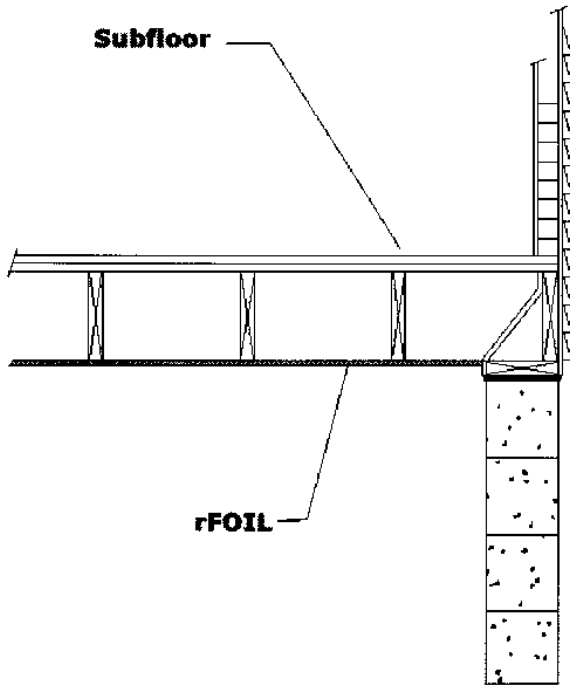

FIGURE 2—CRAWL SPACE APPLICATION

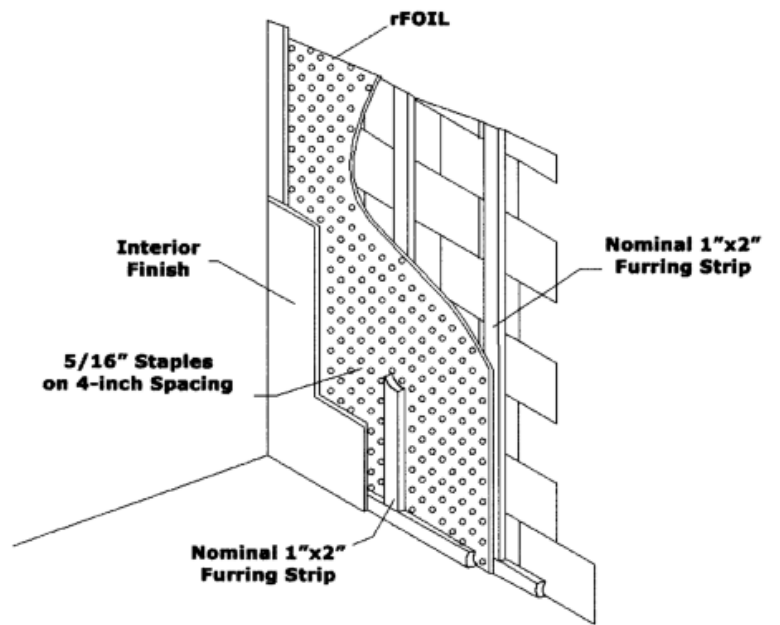

FIGURE 3—DOUBLE FURRED BLOCK WALL APPLICATION
SI: 1 inch = 25.4 mm

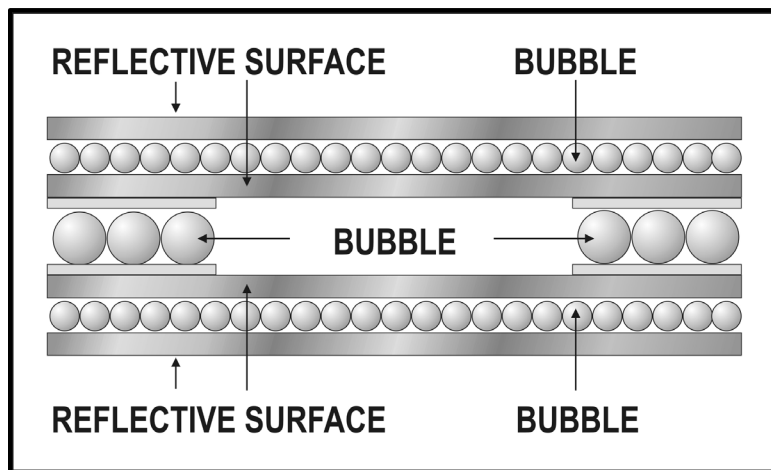
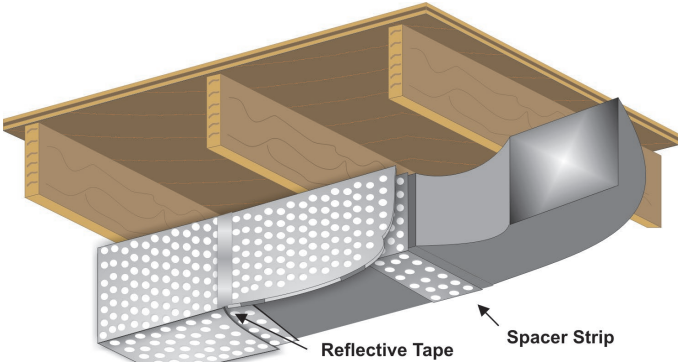
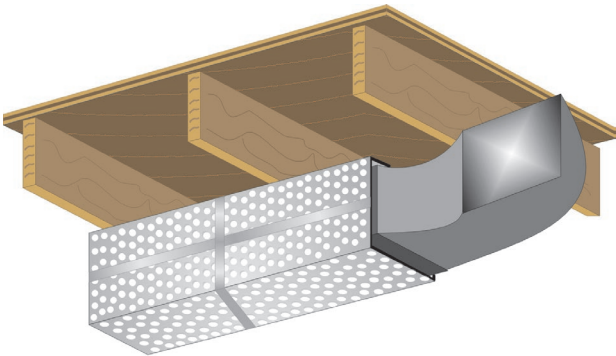

FIGURE 4—BIG-8 SPEC DRAWING



Big-8 Spacer Wrap for an R-8 Value (With Spacer Strips)

FIGURE 5



Big-8 Direct Wrap for an R-6 Value (Without Spacer Strips)

FIGURE 6

DIVISION: 07 00 00—THERMAL AND MOISTURE PROTECTION

Section: 07 21 00—Thermal Insulation

REPORT HOLDER:

COVERTECH FLEXIBLE PACKAGING (DIVISION OF BALCAN PLASTICS INC.)

EVALUATION SUBJECT:

rFOIL™ REFLECTIVE PLASTIC CORE INSULATION AND rFOIL™ BIG-8™ REFLECTIVE PLASTIC CORE DUCT INSULATION

1.0 REPORT PURPOSE AND SCOPE

Purpose:

The purpose of this evaluation report supplement is to indicate that the rFOIL™ Reflective Plastic Core Insulation and rFOIL™ Big-8™ Reflective Plastic Core Duct Insulation, described in ICC-ES evaluation report [ESR-1236](#), have also been evaluated for the codes noted below.

Applicable code edition:

- 2019 California Building Code (CBC)

For evaluation of applicable chapters adopted by the California Office of Statewide Health Planning and Development (OSHPD) AKA: California Department of Health Care Access and Information (HCAI) and the Division of State Architect (DSA), see Sections 2.1.1 and 2.1.2 below.

- 2019 California Residential Code (CRC)

- 2019 California Energy Code (CEC)

2.0 CONCLUSIONS

2.1 CBC, CRC and CMC:

The rFOIL™ Reflective Plastic Core Insulation and rFOIL™ Big-8™ Reflective Plastic Core Duct Insulation, described in Sections 2.0 through 7.0 of the evaluation report [ESR-1236](#), comply with 2019 CBC Sections 720 and 2614 and CRC Section R302.10.1, provided the design and installation are in accordance with the 2018 *International Building Code*® (IBC) and 2018 *International Residential Code*® (IRC) provisions, as applicable, noted in the evaluation report.

The rFOIL™ Big-8™ Reflective Plastic Core Duct Insulation, described in Sections 2.0 through 7.0 of the evaluation report [ESR-1236](#), complies with the 2019 CMC Section 604.1.2, provided the design and installation are in accordance with the 2018 *International Mechanical Code*® (IMC) provisions noted in the evaluation report.

2.1.1 OSHPD: The applicable OSHPD Sections and Chapters of the CBC are beyond the scope of this supplement.

2.1.2 DSA: The applicable DSA Sections and Chapters of the CBC are beyond the scope of this supplement.

2.2 CEC:

The rFOIL™ Reflective Plastic Core Insulation, and rFOIL™ Big-8™ Reflective Plastic Core Duct Insulation, described in Sections 2.0 through 7.0 of the evaluation report [ESR-1236](#), comply with the 2019 CEC, provided the design and installation are in accordance with the 2018 *International Building Code*® (IBC) provisions noted in the evaluation report.

2.2.1 Conditions of Use:

In accordance with Section 110.8 of the 2019 California Energy Code, verification of certification by the Department of Consumer Affairs, Bureau of Household Goods and Services, must be provided to the code official, demonstrating that the insulation conductive thermal performance is approved pursuant to the California Code of Regulations, Title 24, Part 12, Chapters 12-13, Article 3, "Standards for Insulating Material." Certification can be verified with the DCA Bureau of Household Goods and Services using the following link to the bureau's Directory of Certified Insulation Materials: https://bhgs.dca.ca.gov/consumers/ti_directory.pdf

This supplement expires concurrently with the evaluation report, reissued August 2022.