

# ICC-ES Evaluation Report

ESR-2553

Reissued January 2024

This report also contains:

- LABC Supplement

Subject to renewal January 2025

- FBC Supplement

ICC-ES Evaluation Reports are not to be construed as representing aesthetics or any other attributes not specifically addressed, nor are they to be construed as an endorsement of the subject of the report or a recommendation for its use. There is no warranty by ICC Evaluation Service, LLC, express or implied, as to any finding or other matter in this report, or as to any product covered by the report.

Copyright © 2024 ICC Evaluation Service, LLC. All rights reserved.

<p><b>DIVISION: 06 00 00— WOOD, PLASTICS, AND COMPOSITES</b></p> <p><b>Section: 06 05 23— Wood, Plastic, and Composite Fastenings</b></p>	<p><b>REPORT HOLDER: SIMPSON STRONG-TIE COMPANY INC.</b></p> 	<p><b>EVALUATION SUBJECT: SIMPSON STRONG-TIE® TOP-FLANGE HANGERS FOR SAWN LUMBER</b></p>	
---	--	--	---

## 1.0 EVALUATION SCOPE

**Compliance with the following codes:**

- 2021, 2018, 2015, and 2012 [International Building Code® \(IBC\)](#)
- 2021, 2018, 2015, and 2012 [International Residential Code® \(IRC\)](#)

For evaluation for compliance with codes adopted by the [Los Angeles Department of Building and Safety \(LADBS\)](#), see [ESR-2553 LABC and LARC Supplement](#).

**Property evaluated:**

Structural

## 2.0 USES

The Simpson Strong-Tie® top-flange hangers described in this report are used as wood framing connectors in accordance with Section [2304.10.4](#) of the 2021 IBC [Section [2304.10.3](#) of the 2018 and 2015 IBC or Section [2304.9.3](#) of the 2012 IBC]. The products may also be used in structures regulated under the IRC when an engineered design is submitted in accordance with Section [R301.1.3](#) of the IRC.

## 3.0 DESCRIPTION

### 3.1 General:

The Simpson Strong-Tie® top-flange hangers described in this report are U-shaped hangers with one or two flanges that bear onto the supporting wood member or may be welded to a steel beam. The U-shaped stirrup of each hanger has a width and height designed to support sawn lumber joists or beams.

**3.1.1 JB, JBA and LB Hanger Series:** The JB and JBA series hangers are fabricated from No. 18 gage galvanized steel, and the LB and LBAZ hangers are fabricated from No. 14 gage galvanized steel. The top flange must be supported by a wood beam, girder, nailer or ledger. Alternatively, the top flange of the LB and LBAZ hangers may be welded to a steel beam. See [Table 1](#) for hanger dimensions, fastener schedules, and allowable loads. See [Figures 1a](#), [1b](#) and [1c](#) for illustrations of typical LB, JB, JBA and LBAZ hangers, respectively.

**3.1.2 HUTF Hanger Series:** The HUTF hanger series is formed from No. 12 gage galvanized steel. HUTF hangers have two header flanges, which extend over the top of the header, and have predrilled holes for the installation of 16d common nails as shown in [Figure 2b](#). The hanger seat width (W) is sized for the net width of the supported member. HUTF hangers having a seat width equal to or greater than  $2^{9/16}$  inches (65 mm) are available with concealed header flanges (i.e., the portion of the hanger fastened to the carrying header) as shown in [Figure 2b](#). See [Table 2](#) for hanger models, hanger dimensions, fastener schedules, and allowable loads.

**3.1.3 HUSTF Series Hangers:** The HUSTF Series joist hangers are fabricated from No. 14 gage galvanized steel. The hanger has a U-shaped stirrup with prepunched holes for installing nails, minimum 16d common, that must be driven at a 45-degree angle through the supported wood joist and into the carrying wood member. This is described in the manufacturer's installation instructions as double shear nailing. See [Table 3](#) for hanger models, hanger dimensions, fastener schedules, and allowable loads. See [Figure 3a](#) for a drawing of a typical HUSTF hanger, and [Figure 3b](#) for a drawing of a top view of double shear nailing.

**3.1.4 PF, PFB, PFDB, and PFDSB Hanger Series:** The PF hangers support nominally 2-by-4 and 2-by-6 wood members, and are fabricated from No. 18 gage galvanized steel. The PFB, PFDB, and PFDSB hangers support nominally 2-by-4, 2-by-6, and 2-by-8 wood joists, and are fabricated from No. 20 gage galvanized steel. The PFB hangers support a single joist member. The PFDB and PFDSB hangers, which are installed in a saddle configuration over the carrying wood member, support two horizontally aligned joists. The U-shaped portion of the hanger has prepunched holes for installing nails, minimum 10d common, that must be driven at a 45-degree angle through the supported wood joist and into the carrying wood member. This is described as double shear nailing in the installation instructions. See [Table 4](#) for hanger dimensions, fastener schedules, and allowable loads. See [Figure 4a](#) for a drawing of the PF24 and PF26 hangers; [Figure 4b](#) for a drawing of the PF24B hanger; [Figure 4c](#) for a drawing of the PF26B hanger; [Figure 4d](#) for a drawing of the PFD26B and PFDS26B hangers; and [Figure 4e](#) for a top view of double shear nailing.

**3.1.5 RR Ridge Rafter Connector:** The RR ridge rafter connector supports nominally 2-inch-wide sawn wood roof rafters from a sawn wood ridge board or beam. The hanger is fabricated from No. 18 gage galvanized steel. The top flange of the RR connector is configured to interlock with an RR connector installed on the opposing face of the ridge board as shown in [Figure 5](#). The RR connector may be used with a rafter having a maximum slope of 7:12 (30 degrees). See [Table 5](#) for fastener schedules and allowable loads. See [Figure 5](#) for a drawing of the RR connector and a typical connector installation detail.

**3.1.6 DGF, DGHF, and DGBF Hanger Series:** The DGF, DGHF and DGBF Fire Wall Hangers are designed for attaching wood truss, wood I-joist, solid sawn lumber, or structural composite lumber floor framing members to minimum double 2x4 nominal wall top plates, wood beams, girders, or minimum double 2x4 nominal nailers supported continuously by and parallel to a steel beam, prior to the installation of two layers of  $5/8$ -inch-thick (15.9mm) gypsum wallboard. The DGF series hangers are fabricated from No. 12 gage galvanized steel. The DGHF series hangers are fabricated from a No. 10 gage steel U-shaped stirrup that is factory welded to a No. 10 gage steel angle. The DGBF series hangers are fabricated from a No. 7 gage steel U-shaped stirrup that is factory welded to a No. 7 gage steel angle. The top flange must be supported by a wood stud wall top plate, beam, girder, or nailer. See [Table 6](#) for hanger model numbers, hanger seat width ranges, hanger height ranges, required fastener schedules and allowable loads. See [Figures 6a](#) through [6d](#) for product drawings and typical installation details.

**3.1.7 DGT, DGHT Hanger Series:** The DGT and DGHT Fire Wall Hangers are designed for attaching wood truss, wood I-joist, solid sawn lumber, or structural composite lumber floor framing members to minimum double 2x4 nominal wall top plates, wood beams, girders, or minimum double 2x4 nominal nailers supported continuously by and parallel to a steel beam, prior to the installation of two layers of  $5/8$ -inch-thick (15.9mm) gypsum wallboard. The DGT series hangers are fabricated from No. 12 gage galvanized steel. The DGHT series hangers are fabricated from No. 10 gage galvanized steel. The top flange must be supported by a wood stud wall top plate, beam, girder, or nailer. See [Table 7](#) for hanger model numbers, hanger seat width ranges, hanger height ranges, required fastener schedules and allowable loads. See [Figures 7a](#) and [7b](#) for product drawings and typical installation details.

## 3.2 Materials

**3.2.1 Steel:** The hangers described in this report are manufactured from steel complying with [ASTM A653](#), SS designation, Grade 33. The PFB, PFDB, PFDSB hangers may be manufactured from steel complying with ASTM A653, FS designation, Grade 33. The steel used to fabricate the hangers comply with the following:

MODEL SERIES	ASTM STEEL SPECIFICATION	MINIMUM STRENGTH (ksi)		NOMINAL THICKNESS (gage)	MINIMUM BASE-METAL THICKNESS (inch)
		Yield, $F_y$	Tensile, $F_u$		
JB, JBA	A653	33	45	No. 18	0.0445
LB, LBAZ	A653	33	45	No. 14	0.0685
HUTF	A653	33	45	No. 12	0.0975
HUSTF	A653	33	45	No. 14	0.0685
PF	A653	33	45	No. 18	0.0445
PFB	A653	33	45	No. 20	0.0335
PFDB	A653	33	45	No. 20	0.0335
PFDSB	A653	33	45	No. 20	0.0335
RR	A653	33	45	No. 18	0.0445
DGF	A653	33	45	No. 12	0.0975
DGHF	A1011	33	52	No. 10	0.1275
DGBF	A1011	33	52	No. 7	0.1715
DGT	A653	33	45	No. 12	0.0975
DGHT	A653	33	45	No. 10	0.1275

For **SI**: 1 inch = 25.4 mm, 1 psi = 6.895 kPa.

The hangers manufactured from galvanized steel have a minimum G90 zinc coating specification in accordance with ASTM A653. The hangers manufactured from ungalvanized steel have either a painted or powder coated finish. Some models (designated with a model number ending with Z) are available with a G185 zinc coating specification in accordance with ASTM A653. Some models (designated with a model number ending with HDG) are available with a hot-dip galvanization, also known as “batch” galvanization, in accordance with [ASTM A123](#), with a minimum specified coating weight of 2.0 ounces of zinc per square foot of surface area (610 g/m<sup>2</sup>), total for both sides. Model numbers in this report do not include the Z or HDG ending, but the information shown herein applies. The lumber treater and the holder of this report (Simpson Strong-Tie Company) should be contacted for recommendations on the appropriate level of corrosion resistance to specify for use of the steel connectors in contact with the specific proprietary preservative-treated or fire-retardant-treated lumber.

**3.2.2 Wood:** Wood members with which the connectors are used must be either sawn lumber or engineered lumber having a minimum specific gravity of 0.50 (minimum equivalent specific gravity of 0.50 for engineered lumber), and having a maximum moisture content of 19 percent (16 percent for engineered lumber) except as noted in Section [4.1](#). The thickness of the supporting wood member (header) must be equal to or greater than the length of the fasteners specified in the tables in this report, or as required by wood member design, whichever is greater.

**3.2.3 Nails:** Nails used for hangers described in this report must comply with the material requirements, physical properties, tolerances, workmanship, protective coating and finishes, certification, and packaging and package marking requirements specified in [ASTM F1667](#). The nails must have the following minimum fastener dimensions and bending yield strengths ( $F_{yb}$ ):

FASTENER	SHANK DIAMETER (inch)	NAIL LENGTH (inches)	$F_{yb}$ (psi)
10d × 1½	0.148	1½	90,000
10d × 2½	0.148	2½	90,000
10d	0.148	3	90,000
16d	0.162	3½	90,000

For **SI**: 1 inch = 25.4 mm, 1 psi = 6.895 kPa.

Fasteners used in contact with preservative-treated or fire-retardant-treated lumber must comply with Section [2304.10.6](#) of the 2021 IBC [Section [2304.10.5](#) of the 2018 and 2015 IBC or Section [2304.9.5](#) of the 2012 IBC] and Section [R317.3](#) of the IRC, as applicable. For use with treated lumber, the lumber treater or this report holder (Simpson Strong-Tie Company), or both, should be contacted for recommendations on the appropriate level of corrosion resistance to specify for the fasteners as well as the connection capacities of fasteners used with the specific proprietary preservative treated or fire-retardant-treated lumber.

## 4.0 DESIGN AND INSTALLATION

### 4.1 Design:

The tabulated allowable loads shown in this report are based on allowable stress design (ASD) and include the load duration factor,  $C_D$ , corresponding with the applicable loads in accordance with the NDS.

Tabulated allowable loads apply to products connected to wood used under dry conditions and where sustained temperatures are 100°F (37.8°C) or less. When products are installed to wood having a moisture content greater than 19 percent (16 percent for engineered wood products), or where wet service is expected, the allowable loads must be adjusted by the wet service factor for mechanical connections,  $C_M$ , specified in the NDS. When connectors are installed in wood that will experience sustained exposure to temperatures exceeding 100°F (37.8°C), the allowable loads in this report must be adjusted by the temperature factor,  $C_t$ , specified in the NDS.

Connected wood members must be analyzed for load-carrying capacity at the connection in accordance with the NDS.

### 4.2 Installation:

Installation of the connectors must be in accordance with this evaluation report and the manufacturer's published installation instructions. In the event of a conflict between this report and the manufacturer's published installation instructions, this report governs.

## 5.0 CONDITIONS OF USE:

The Simpson Strong-Tie® top-flange hangers described in this report comply with, or are suitable alternatives to what is specified in, those codes listed in Section 1.0 of this report, subject to the following conditions:

- 5.1 The connectors must be manufactured, identified and installed in accordance with this report and the manufacturer's published installation instructions. A copy of the instructions must be available at the jobsite at all times during installation.
- 5.2 Calculations showing compliance with this report must be submitted to the code official. The calculations must be prepared by a registered design professional where required by the statutes of the jurisdiction in which the project is to be constructed.
- 5.3 Adjustment factors noted in Section 4.1 and the applicable codes must be considered, where applicable.
- 5.4 Connected wood members and fasteners must comply, respectively, with Sections 3.2.2 and 3.2.3 of this report.
- 5.5 Use of connectors with preservative treated or fire-retardant treated lumber must be in accordance with Section 3.2.1 of this report. Use of fasteners with preservative treated or fire-retardant treated lumber must be in accordance with Section 3.2.3 of this report.

## 6.0 EVIDENCE SUBMITTED

Data in accordance with the [ICC-ES Acceptance Criteria for Joist Hangers and Similar Devices \(AC13\)](#), dated October 2018 (editorially revised December 2020).

## 7.0 IDENTIFICATION

- 7.1 The ICC-ES mark of conformity, electronic labeling, or the evaluation report number (ICC-ES [ESR-2553](#)) along with the name, registered trademark, or registered logo of the report holder must be included in the product label.
- 7.2 In addition, the products described in this report are identified with a die-stamped label or an adhesive label, indicating the name of the manufacturer (Simpson Strong-Tie), the model number, and the number of an index evaluation report ([ESR-2523](#)) that is used as an identifier for the products recognized in this report.
- 7.3 The report holder's contact information is the following:

**SIMPSON STRONG-TIE COMPANY INC.**  
**5956 WEST LAS POSITAS BOULEVARD**  
**PLEASANTON, CALIFORNIA 94588**  
**(800) 999-5099**  
[www.strongtie.com](http://www.strongtie.com)

TABLE 1—ALLOWABLE LOADS FOR THE JB, JBA, LB AND LBAZ SERIES JOIST HANGERS

HANGER SERIES	MODEL NO.	HANGER DIMENSIONS <sup>1</sup> (inches)				COMMON NAILS (Quantity – Size)		ALLOWABLE LOADS <sup>2,3,4</sup> (lbs)	
		W	H	B	TF	Header	Joist	Uplift <sup>5</sup> where C <sub>D</sub> =1.6	Download where C <sub>D</sub> = 1.0, C <sub>D</sub> = 1.15, C <sub>D</sub> = 1.25
JB	JB26	1 <sup>9</sup> / <sub>16</sub>	5 <sup>3</sup> / <sub>8</sub>	1 <sup>1</sup> / <sub>2</sub>	1 <sup>5</sup> / <sub>16</sub>	4–10d	—	—	995
	JB28	1 <sup>9</sup> / <sub>16</sub>	7 <sup>1</sup> / <sub>4</sub>	1 <sup>1</sup> / <sub>2</sub>	1 <sup>5</sup> / <sub>16</sub>	4–10d	—	—	955
JBA	JB210A	1 <sup>9</sup> / <sub>16</sub>	9 <sup>3</sup> / <sub>16</sub>	2	1 <sup>7</sup> / <sub>16</sub>	6–16d	2–10d x 1 <sup>1</sup> / <sub>2</sub>	260	1685
	JB212A	1 <sup>9</sup> / <sub>16</sub>	11 <sup>1</sup> / <sub>8</sub>	2	1 <sup>7</sup> / <sub>16</sub>	6–16d	2–10d x 1 <sup>1</sup> / <sub>2</sub>	260	1685
	JB214A	1 <sup>9</sup> / <sub>16</sub>	13 <sup>1</sup> / <sub>8</sub>	2	1 <sup>7</sup> / <sub>16</sub>	6–16d	2–10d x 1 <sup>1</sup> / <sub>2</sub>	260	1685
LB	LB26	1 <sup>9</sup> / <sub>16</sub>	5 <sup>3</sup> / <sub>8</sub>	1 <sup>1</sup> / <sub>2</sub>	1 <sup>1</sup> / <sub>2</sub>	4–16d	2–10d x 1 <sup>1</sup> / <sub>2</sub>	380	1,135
	LB28	1 <sup>9</sup> / <sub>16</sub>	7 <sup>1</sup> / <sub>4</sub>	1 <sup>1</sup> / <sub>2</sub>	1 <sup>1</sup> / <sub>2</sub>	4–16d	2–10d x 1 <sup>1</sup> / <sub>2</sub>	380	1,135
	LB216	1 <sup>9</sup> / <sub>16</sub>	15 <sup>1</sup> / <sub>8</sub>	2	1 <sup>1</sup> / <sub>2</sub>	4–16d	2–10d x 1 <sup>1</sup> / <sub>2</sub>	380	1,480
LBAZ	LB210AZ	1 <sup>9</sup> / <sub>16</sub>	9 <sup>3</sup> / <sub>16</sub>	2	1 <sup>7</sup> / <sub>16</sub>	6–16d	2–10d x 1 <sup>1</sup> / <sub>2</sub>	355	1865
	LB212AZ	1 <sup>9</sup> / <sub>16</sub>	11 <sup>1</sup> / <sub>8</sub>	2	1 <sup>7</sup> / <sub>16</sub>	6–16d	2–10d x 1 <sup>1</sup> / <sub>2</sub>	355	1865
	LB214AZ	1 <sup>9</sup> / <sub>16</sub>	13 <sup>1</sup> / <sub>8</sub>	2	1 <sup>7</sup> / <sub>16</sub>	6–16d	2–10d x 1 <sup>1</sup> / <sub>2</sub>	355	1865

For SI: 1 inch = 25.4 mm, 1 lbf = 4.45 N.

<sup>1</sup>Refer to Figure 1b (this page) for definitions of hanger nomenclature (W, H, B, TF).

<sup>2</sup>Tabulated allowable loads must be selected based on duration of load as permitted by the applicable building code.

<sup>3</sup>LB and LBAZ series hangers provide torsional resistance. JBA series hangers provide torsional resistance up to a joist depth of 1<sup>1</sup>/<sub>8</sub> inches. Torsional resistance is defined as a moment of not less than 75 pounds (334 N) times the depth of the joist at which the lateral movement of the top or bottom of the joist with respect to the vertical position of the joist is 0.125 inch (3.2 mm). JB214A hangers provide a torsional resistance of 72 pounds times the depth of the joist in accordance with Section 2304.10.4 of the 2021 IBC or Section 2304.10.3 of the 2018 and 2015 IBC.

<sup>4</sup>The LB hangers are permitted for welded applications to a supporting steel member provided 1/8-inch thick (throat) by 1<sup>1</sup>/<sub>2</sub>-inch long fillet welds are placed along each edge (dimension "TF" in Figure 1b) of each top flange. Welds must conform to the current A.W.S. D1.3 structural welding code for sheet steel. Uplift loads do not apply for welded hangers.

<sup>5</sup>The uplift loads have been increased for wind or earthquake loading with no further increase allowed. The allowable uplift loads must be reduced when other load durations govern.

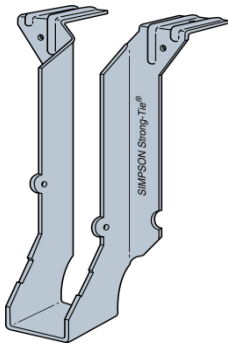

FIGURE 1a—LB HANGER

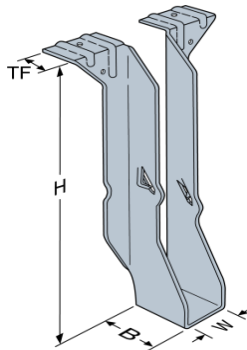

FIGURE 1b—JB HANGER

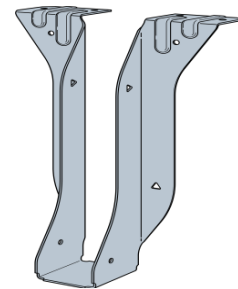

FIGURE 1c—JBA HANGER  
(LBAZ HANGER SIMILAR)

TABLE 2—ALLOWABLE LOADS FOR THE HUTF SERIES JOIST HANGERS

MODEL NO.	HANGER DIMENSIONS <sup>1</sup> (in)				FASTENERS (Quantity–Size)		ALLOWABLE LOADS <sup>2,3,4</sup>			
	W	H	B	TF	Header	Joist	Uplift <sup>5</sup>			
							Download			
							C <sub>D</sub> = 1.6	C <sub>D</sub> = 1.0	C <sub>D</sub> = 1.15	C <sub>D</sub> = 1.25
HU24TF	1 <sup>9</sup> / <sub>16</sub>	3 <sup>7</sup> / <sub>16</sub>	2 <sup>1</sup> / <sub>4</sub>	2 <sup>1</sup> / <sub>2</sub>	6–16d	2–10d x 1 <sup>1</sup> / <sub>2</sub>	190	1,865	1,865	1,865
HU26TF		5 <sup>3</sup> / <sub>8</sub>			10–16d	4–10d x 1 <sup>1</sup> / <sub>2</sub>	660	2,550	2,550	2,550
HU28TF		7 <sup>1</sup> / <sub>8</sub>			10–16d	4–10d x 1 <sup>1</sup> / <sub>2</sub>	700	2,910	2,970	3,010
HU210TF		9 <sup>1</sup> / <sub>8</sub>			12–16d	4–10d x 1 <sup>1</sup> / <sub>2</sub>	700	2,910	2,970	3,010
HU212TF		11			14–16d	6–10d x 1 <sup>1</sup> / <sub>2</sub>	700	3,070	3,070	3,070
HU214TF		13			16–16d	6–10d x 1 <sup>1</sup> / <sub>2</sub>	1,140	2,955	3,045	3,110
HU216TF		15			18–16d	8–10d x 1 <sup>1</sup> / <sub>2</sub>	1,065	3,235	3,360	3,440
HU34TF	2 <sup>9</sup> / <sub>16</sub>	3 <sup>7</sup> / <sub>16</sub>	2 <sup>1</sup> / <sub>2</sub>	2 <sup>1</sup> / <sub>2</sub>	8–16d	2–10d x 1 <sup>1</sup> / <sub>2</sub>	370	2,050	2,050	2,050
HU36TF		5 <sup>3</sup> / <sub>8</sub>			10–16d	4–10d x 1 <sup>1</sup> / <sub>2</sub>	705	2,785	2,785	2,785
HU38TF		7 <sup>1</sup> / <sub>8</sub>			12–16d	4–10d x 1 <sup>1</sup> / <sub>2</sub>	640	3,265	3,265	3,265
HU310TF		9 <sup>1</sup> / <sub>8</sub>			14–16d	6–10d x 1 <sup>1</sup> / <sub>2</sub>	1,220	3,945	3,945	3,945
HU312TF		11			16–16d	6–10d x 1 <sup>1</sup> / <sub>2</sub>	1,140	4,590	4,590	4,590
HU314TF		13			18–16d	6–10d x 1 <sup>1</sup> / <sub>2</sub>	1,065	4,030	4,030	4,030
HU316TF		15			20–16d	8–10d x 1 <sup>1</sup> / <sub>2</sub>	1,125	4,050	4,050	4,050
HU24-2TF	3 <sup>1</sup> / <sub>8</sub>	3 <sup>7</sup> / <sub>16</sub>	2 <sup>1</sup> / <sub>2</sub>	2 <sup>1</sup> / <sub>2</sub>	8–16d	2–10d	370	2,050	2,050	2,050
HU26-2TF		5 <sup>3</sup> / <sub>8</sub>			10–16d	4–16d	815	2,785	2,785	2,785
HU28-2TF		7 <sup>1</sup> / <sub>8</sub>			12–16d	4–16d	815	3,265	3,265	3,265
HU210-2TF		9 <sup>1</sup> / <sub>8</sub>			14–16d	6–16d	1,220	3,945	3,945	3,945
HU212-2TF		11			16–16d	6–16d	1,220	4,590	4,590	4,590
HU214-2TF		13			18–16d	8–16d	1,330	4,030	4,030	4,030
HU216-2TF		15			20–16d	8–16d	1,400	4,050	4,050	4,050
HU44TF	3 <sup>9</sup> / <sub>16</sub>	3 <sup>7</sup> / <sub>16</sub>	2 <sup>1</sup> / <sub>2</sub>	2 <sup>1</sup> / <sub>2</sub>	8–16d	2–10d	370	2,050	2,050	2,050
HU46TF		5 <sup>3</sup> / <sub>8</sub>			10–16d	4–16d	815	2,785	2,785	2,785
HU48TF		7 <sup>1</sup> / <sub>8</sub>			12–16d	4–16d	815	3,265	3,265	3,265
HU410TF		9 <sup>1</sup> / <sub>8</sub>			14–16d	6–16d	1,220	3,945	3,945	3,945
HU412TF		11			16–16d	6–16d	1,220	4,590	4,590	4,590
HU414TF		13			18–16d	8–16d	1,330	4,030	4,030	4,030
HU416TF		15			20–16d	8–16d	1,400	4,050	4,050	4,050
HU210-3TF	4 <sup>11</sup> / <sub>16</sub>	9 <sup>1</sup> / <sub>8</sub>	2 <sup>1</sup> / <sub>2</sub>	2 <sup>1</sup> / <sub>2</sub>	14–16d	6–16d	1,420	3,945	3,945	3,945
HU212-3TF		11			16–16d	6–16d	1,420	4,590	4,590	4,590
HU214-3TF		13			18–16d	8–16d	1,560	4,030	4,030	4,030
HU216-3TF		15			20–16d	8–16d	1,640	4,050	4,050	4,050
HU66TF	5 <sup>1</sup> / <sub>2</sub>	5 <sup>3</sup> / <sub>8</sub>	2 <sup>1</sup> / <sub>2</sub>	2 <sup>1</sup> / <sub>2</sub>	10–16d	4–16d	945	2,785	2,785	2,785
HU68TF		7 <sup>1</sup> / <sub>8</sub>			12–16d	4–16d	945	3,265	3,265	3,265
HU610TF		9 <sup>1</sup> / <sub>8</sub>			14–16d	6–16d	1,420	3,945	3,945	3,945
HU612TF		11			16–16d	6–16d	1,420	4,590	4,590	4,590
HU614TF		13			18–16d	8–16d	1,560	4,030	4,030	4,030
HU616TF		15			20–16d	8–16d	1,640	4,050	4,050	4,050

For SI: 1 inch = 25.4 mm, 1 pound = 4.45 N.

<sup>1</sup>Refer to Figure 2a (next page) for definitions of hanger nomenclature (W, H, B, TF).

<sup>2</sup>Tabulated allowable loads must be selected based on duration of load as permitted by the applicable building code.

<sup>3</sup>The minimum wood header or ledger size that can be used with HUTF hangers is 3<sup>1</sup>/<sub>2</sub> inches. See Figure 2b (next page).

<sup>4</sup>The hanger provides a torsional resistance up to a maximum joist depth of 16<sup>1</sup>/<sub>2</sub> inches, where torsional resistance is defined as a moment of not less than 75 pounds (334 N) times the depth of the joist at which the lateral movement of the top or bottom of the joist with respect to the vertical position of the joist is 0.125 inch (3.2 mm).

<sup>5</sup>Tabulated allowable uplift loads have been increased for wind or earthquake loading with no further increase allowed. The allowable uplift loads must be reduced when other load durations govern.



TABLE 3—ALLOWABLE LOADS FOR THE HUSTF SERIES JOIST HANGERS

MODEL NO.	DIMENSIONS <sup>1</sup> (inches)				FASTENERS (Quantity – Size)		ALLOWABLE LOADS <sup>2,3</sup> (lbs)			
	W	H	B	TF	Header	Joist <sup>4</sup>	Uplift <sup>5</sup>	Download		
							C <sub>D</sub> = 1.6	C <sub>D</sub> = 1.0	C <sub>D</sub> = 1.15	C <sub>D</sub> = 1.25
HUS26-2TF	3 <sup>1</sup> / <sub>8</sub>	5 <sup>3</sup> / <sub>8</sub>	2	1 <sup>3</sup> / <sub>4</sub>	6–16d	4–16d	1,200	2,440	2,440	2,440
HUS28-2TF	3 <sup>1</sup> / <sub>8</sub>	7 <sup>1</sup> / <sub>4</sub>	2	1 <sup>3</sup> / <sub>8</sub>	8–16d	6–16d	1,765	3,400	3,400	3,400
HUS210-2TF	3 <sup>1</sup> / <sub>8</sub>	9 <sup>1</sup> / <sub>4</sub>	2	1 <sup>1</sup> / <sub>2</sub>	10–16d	8–16d	2,315	3,735	4,065	4,275
HUS212-2TF	3 <sup>1</sup> / <sub>8</sub>	11 <sup>1</sup> / <sub>8</sub>	2	2 <sup>1</sup> / <sub>4</sub>	10–16d	8–16d	2,080	4,375	4,375	4,375
HUS214-2TF	3 <sup>1</sup> / <sub>8</sub>	13 <sup>1</sup> / <sub>8</sub>	2	2 <sup>1</sup> / <sub>4</sub>	12–16d	8–16d	2,715	4,065	4,065	4,065
HUS46TF	3 <sup>9</sup> / <sub>16</sub>	5 <sup>3</sup> / <sub>8</sub>	2	1 <sup>9</sup> / <sub>16</sub>	6–16d	4–16d	1,200	2,440	2,440	2,440
HUS48TF	3 <sup>9</sup> / <sub>16</sub>	7 <sup>1</sup> / <sub>4</sub>	2	1 <sup>9</sup> / <sub>16</sub>	8–16d	6–16d	1,765	3,345	3,400	3,400
HUS410TF	3 <sup>9</sup> / <sub>16</sub>	9 <sup>1</sup> / <sub>4</sub>	2	1 <sup>1</sup> / <sub>4</sub>	10–16d	8–16d	2,315	3,515	3,845	4,060
HUS412TF	3 <sup>9</sup> / <sub>16</sub>	11 <sup>1</sup> / <sub>8</sub>	2	2 <sup>1</sup> / <sub>16</sub>	10–16d	8–16d	2,080	4,375	4,375	4,375
HUS414TF	3 <sup>9</sup> / <sub>16</sub>	13 <sup>1</sup> / <sub>8</sub>	2	2 <sup>1</sup> / <sub>16</sub>	12–16d	8–16d	2,715	4,065	4,065	4,065

For SI: 1 lb = 4.45 N, 1 inch = 25.4 mm.

<sup>1</sup>Refer to Figure 3a (this page) for definitions of hanger nomenclature (W, H, B, TF).

<sup>2</sup>Tabulated allowable load capacities must be selected based on duration of load as permitted by the applicable building code.

<sup>3</sup>The HUSTF Series hangers provide torsional resistance, which is defined as a moment of not less than 75 pounds (334 N) times the depth of the joist at which the lateral movement of the top or bottom of the joist with respect to the vertical position of the joist is 0.125 inch (3.2 mm).

<sup>4</sup>The U-shaped portion of the hangers have pre-punched holes for the installation of joist that are driven at a 45-degree angle through the joist and into the header, which is described as double shear nailing in the installation instructions. See Figure 3b (this page).

<sup>5</sup>The uplift loads have been increased for wind or earthquake loading with no further increase allowed. The allowable uplift loads must be reduced when other load durations govern.

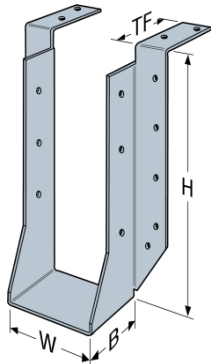

FIGURE 2a—HUTF HANGER SERIES  
(See Table 2)

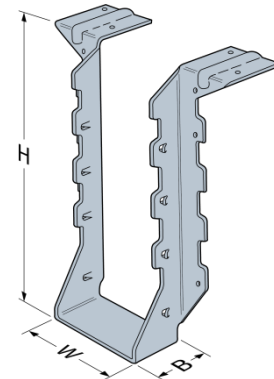

FIGURE 3a—HUSTF HANGER SERIES  
(See Table 3)

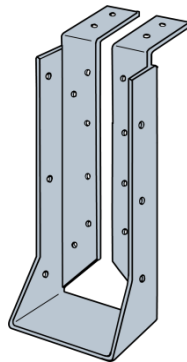

FIGURE 2b—HUTF HANGER (with concealed flanges)  
(See Table 2)

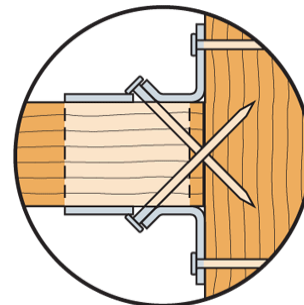

FIGURE 3b—TOP VIEW OF DOUBLE SHEAR NAILING  
REQUIRED FOR HUSTF HANGERS  
(See Footnote 4, Table 3)

TABLE 4—ALLOWABLE LOADS FOR THE PF SERIES JOIST HANGERS

MODEL NO.	DIMENSIONS <sup>1</sup> (inches)					FASTENERS (Quantity—Size)		ALLOWABLE LOADS <sup>2,3</sup> (lbs)			
	W	H	B	TF	S	Header	Joist <sup>4</sup>	Uplift <sup>5</sup>			
								Download			
								C <sub>D</sub> = 1.6	C <sub>D</sub> = 1.0	C <sub>D</sub> = 1.15	C <sub>D</sub> = 1.25
PF24	1 <sup>9</sup> / <sub>16</sub>	3 <sup>3</sup> / <sub>8</sub>	1 <sup>1</sup> / <sub>2</sub>	1 <sup>1</sup> / <sub>16</sub>	—	2–10d	2–10d	300	1,255	1,255	1,255
PF26	1 <sup>9</sup> / <sub>16</sub>	5 <sup>5</sup> / <sub>16</sub>	1 <sup>1</sup> / <sub>2</sub>	1 <sup>1</sup> / <sub>16</sub>	—	2–10d	2–10d	300	1,255	1,255	1,255
PF24B	1 <sup>9</sup> / <sub>16</sub>	3 <sup>3</sup> / <sub>8</sub>	1 <sup>1</sup> / <sub>4</sub>	1 <sup>1</sup> / <sub>2</sub>		2–10d	2–10d	375	1005	1005	1005
PF26B	1 <sup>9</sup> / <sub>16</sub>	5 <sup>3</sup> / <sub>8</sub>	1 <sup>1</sup> / <sub>4</sub>	1 <sup>1</sup> / <sub>2</sub>		2–10d	4–10d	625	1200	1200	1200
PF28B	1 <sup>9</sup> / <sub>16</sub>	7 <sup>1</sup> / <sub>8</sub>	1 <sup>1</sup> / <sub>4</sub>	1 <sup>1</sup> / <sub>2</sub>		2–10d	6–10d	850	1580	1650	1650
PFD24B	1 <sup>9</sup> / <sub>16</sub>	3 <sup>3</sup> / <sub>8</sub>	1 <sup>1</sup> / <sub>4</sub>		1 <sup>9</sup> / <sub>16</sub>	2–10d	2–10d	300	1090	1090	1090
PFD26B	1 <sup>9</sup> / <sub>16</sub>	5 <sup>3</sup> / <sub>8</sub>	1 <sup>1</sup> / <sub>4</sub>		1 <sup>9</sup> / <sub>16</sub>	2–10d	4–10d	650	1290	1290	1290
PFD28B	1 <sup>9</sup> / <sub>16</sub>	7 <sup>1</sup> / <sub>8</sub>	1 <sup>1</sup> / <sub>4</sub>		1 <sup>9</sup> / <sub>16</sub>	2–10d	6–10d	1050	1580	1680	1745
PFDS24B	1 <sup>9</sup> / <sub>16</sub>	3 <sup>3</sup> / <sub>8</sub>	1 <sup>1</sup> / <sub>4</sub>		3 <sup>3</sup> / <sub>16</sub>	4–10d	2–10d	300	1090	1090	1090
PFDS26B	1 <sup>9</sup> / <sub>16</sub>	5 <sup>3</sup> / <sub>8</sub>	1 <sup>1</sup> / <sub>4</sub>		3 <sup>3</sup> / <sub>16</sub>	4–10d	4–10d	650	1290	1290	1290
PFDS28B	1 <sup>9</sup> / <sub>16</sub>	7 <sup>1</sup> / <sub>8</sub>	1 <sup>1</sup> / <sub>4</sub>		3 <sup>3</sup> / <sub>16</sub>	4–10d	6–10d	1050	1580	1680	1745

For SI: 1 inch = 25.4 mm, 1 pound = 4.45 N.

<sup>1</sup>Refer to Figures 4a to 4c for definitions of PF and PFB hangers nomenclature (W, H, B, TF). Refer to Figures 4d for definitions of PFD and PFDS hangers nomenclature (W, H, B, S).

<sup>2</sup>Tabulated allowable load capacities must be selected based on duration of load as permitted by the applicable building code.

<sup>3</sup>The connectors provide a torsional resistance up to a maximum joist depth of 5<sup>1</sup>/<sub>2</sub> inches for PF hangers and 7<sup>1</sup>/<sub>2</sub> inches for PFB, PFD, and PFDS hangers, where torsional resistance is defined as a moment of not less than 75 pounds (334 N) times the depth of the joist at which the lateral movement of the top or bottom of the joist with respect to the vertical position of the joist is 0.125 inch (3.2 mm).

<sup>4</sup>The U-shaped portion of the hangers have pre-punched holes for the installation of nails that are driven at a 45-degree angle through the joist and into the header, which is described as double shear nailing in the installation instructions. See Figure 4e.

<sup>5</sup>The uplift loads have been increased for wind or earthquake loading with no further increase is allowed. The allowable uplift loads must be reduced when other load durations govern.

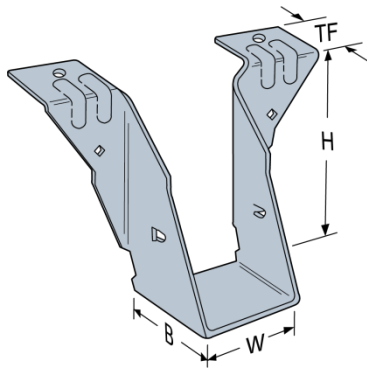

FIGURE 4a—PF24 and PF26 HANGERS

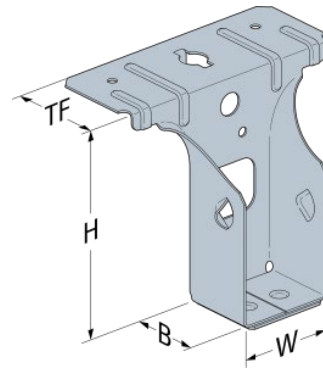

FIGURE 4b—PF24B HANGER

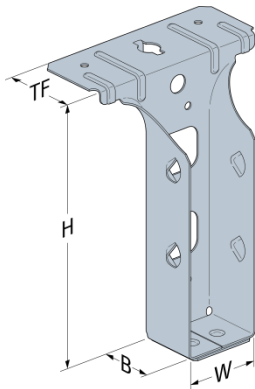

FIGURE 4c—PF26B HANGERS

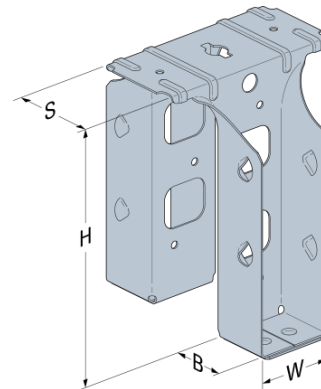
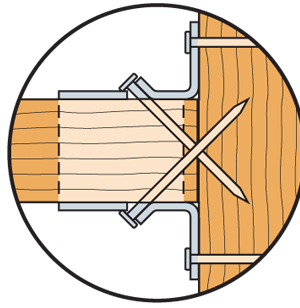

FIGURE 4d—PFD26B and PFDS26B SIMILAR HANGERS





**FIGURE 4e—TOP VIEW OF DOUBLE SHEAR NAILING REQUIRED FOR PF, PFB, PFDB, PFDSB HANGERS**  
(See Footnote 4 to [Table 4](#))

**TABLE 5—ALLOWABLE LOADS FOR THE RR RIDGE RAFTER CONNECTOR**

MODEL NO.	FASTENERS (Quantity – Size)		ALLOWABLE LOADS <sup>1,2</sup> (lbs)		
	Header	Joist	C <sub>D</sub> = 1.0	C <sub>D</sub> = 1.15	C <sub>D</sub> = 1.25
RR	4–10d x 1½	4–10d x 1½	330	330	330

For SI: 1 inch = 25.4 mm, 1 pound = 4.45 N.

<sup>1</sup>The connector may be used with a rafter slope up to 30 degrees maximum.

<sup>2</sup>RR hangers provide a torsional resistance up to a maximum joist depth of 13½ inches, where torsional resistance is defined as a moment of not less than 75 pounds (334 N) times the depth of the joist at which the lateral movement of the top or bottom of the joist with respect to the vertical position of the joist is 0.125 inch (3.2 mm).

<sup>3</sup>Tabulated allowable loads must be selected based on duration of load as permitted by the applicable building code.

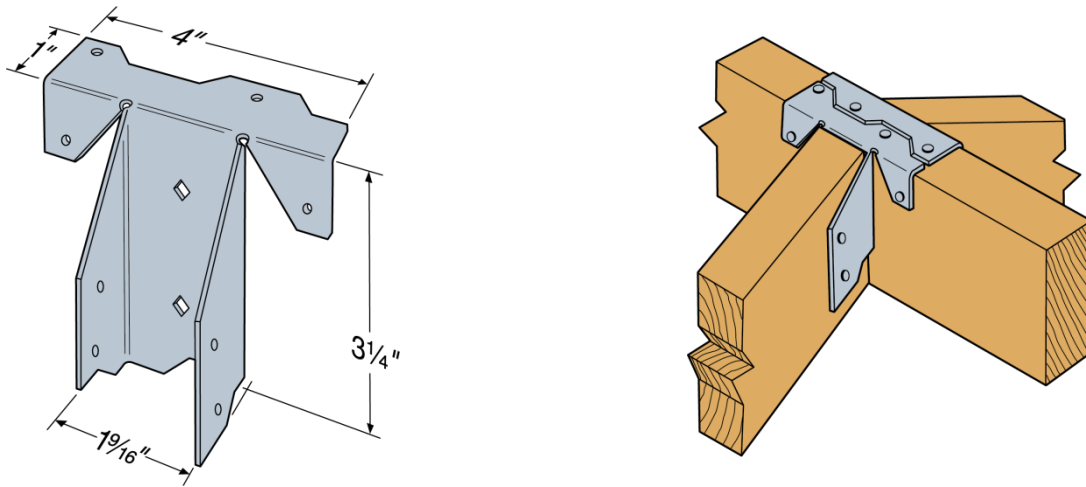

**FIGURE 5—RR RIDGE RAFTER CONNECTOR**

TABLE 6—ALLOWABLE LOADS FOR THE DG, DGH AND DGB SERIES JOIST HANGERS

MODEL NO.	DIMENSIONS <sup>1</sup> (inches)				FASTENERS (Quantity – Size)			ALLOWABLE LOADS <sup>2,3,4,5</sup> (lbs)			
	W	H	B	TF	Top	Face	Joist	Uplift <sup>6</sup>	Download		
								C <sub>D</sub> = 1.6	C <sub>D</sub> = 1.0	C <sub>D</sub> = 1.15	C <sub>D</sub> = 1.25
DGF	1½ - 3 <sup>5</sup> / <sub>8</sub>	7¼ - 11 ¼	2	2 <sup>5</sup> / <sub>8</sub>	6–10d	—	6–10dx1½	315	1420	1420	1420
DGF	1½ - 3 <sup>5</sup> / <sub>8</sub>	11 <sup>7</sup> / <sub>8</sub> - 24	2	2 <sup>5</sup> / <sub>8</sub>	6–10d	—	6–10d x1½	315	1705	1705	1705
DGHF	1¾ - 3 <sup>5</sup> / <sub>8</sub>	9¼ - 24	2¼	3¼	5–10d	2–10d	8–10d x1½	900	2135	2135	2135
DGBF	3 <sup>5</sup> / <sub>8</sub> - 7¼	9¼ - 24	2½	2 <sup>5</sup> / <sub>8</sub>	8–10d	4–10d	8–10d	1040	2260	2260	2260
DGBF Stud Below <sup>5</sup>	3 <sup>5</sup> / <sub>8</sub> - 7¼	9¼ - 24	2½	2 <sup>5</sup> / <sub>8</sub>	8–10d	4–10d	8–10d	1040	3015	3015	3015

For SI: 1 lb = 4.45 N, 1 inch = 25.4 mm.

<sup>1</sup>Refer to Figures 6a through 6c (this page) for definitions of hanger nomenclature (W, H, B, TF).

<sup>2</sup>Tabulated allowable load capacities must be selected based on duration of load as permitted by the applicable building code.

<sup>3</sup>Tabulated allowable loads are based on a wall assembly consisting of minimum 2x4 double top plate members with studs spaced not more than 16 inches on center. Top plate member splices must occur at stud location.

<sup>4</sup>Hangers spaced closer than 16 inches on center shall reduce capacity proportionately.

<sup>5</sup>DGBF allowable loads with studs below require a minimum 2x4 double stud in the wall centered on the hanger. Studs shall be design by a registered design professional.

<sup>6</sup>The uplift loads have been increased for wind or earthquake loading with no further increase allowed. The allowable uplift loads must be reduced when other load durations govern.

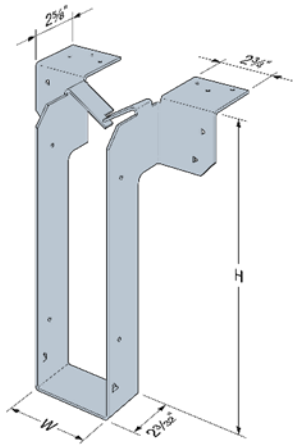

a. DGF HANGER

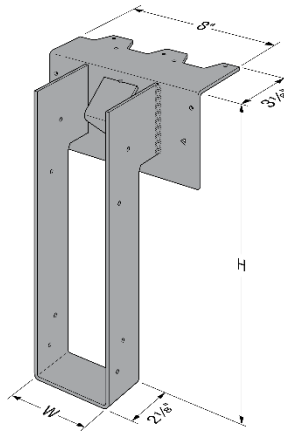

b. DGHF HANGER

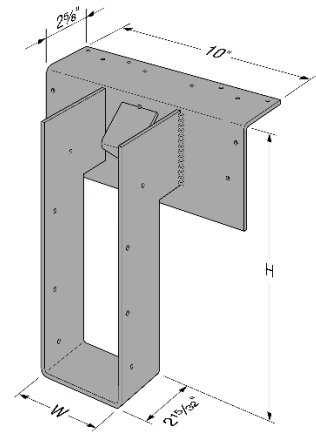

c. DGBF HANGER

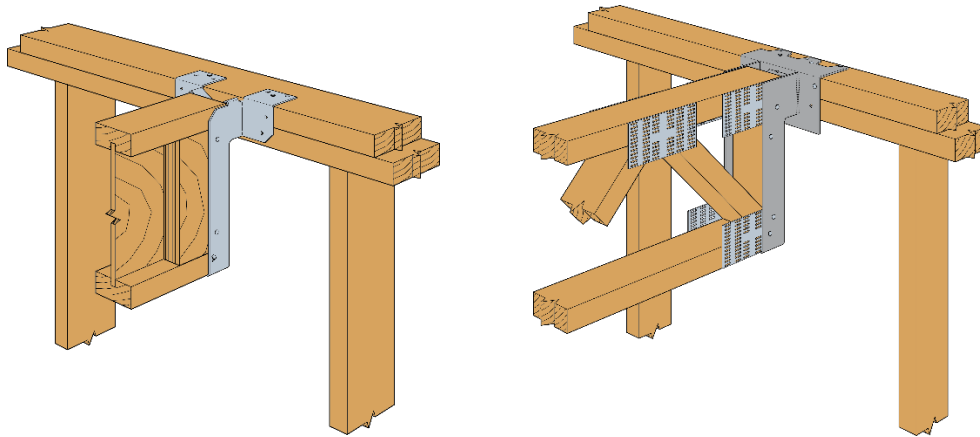

d. TYPICAL INSTALLATIONS

FIGURE 6—PRODUCT DRAWINGS AND TYPICAL INSTALLATIONS

TABLE 7—ALLOWABLE LOADS FOR THE DGT AND DGHT SERIES JOIST HANGERS

MODEL NO.	DIMENSIONS <sup>1</sup> (inches)				FASTENERS (Quantity – Size)			ALLOWABLE LOADS <sup>2,3,4,5</sup> (lbs)			
	W	H	B	TF	Top	Face	Joist	Uplift <sup>6</sup>		Download	
								C <sub>D</sub> = 1.6	C <sub>D</sub> = 1.0	C <sub>D</sub> = 1.15	C <sub>D</sub> = 1.25
DGT	1½ - 3 <sup>5</sup> / <sub>8</sub>	7 <sup>1</sup> / <sub>4</sub> - 11 ¼	2½	3 <sup>1</sup> / <sub>8</sub>	6–10dx2 <sup>1</sup> / <sub>2</sub>	4–10dx2 <sup>1</sup> / <sub>2</sub>	6–10dx1 <sup>1</sup> / <sub>2</sub>	640	1860	1860	1860
DGT	1½ - 3 <sup>5</sup> / <sub>8</sub>	11 <sup>7</sup> / <sub>8</sub> - 24	2½	3 <sup>1</sup> / <sub>8</sub>	6–10dx2 <sup>1</sup> / <sub>2</sub>	4–10dx2 <sup>1</sup> / <sub>2</sub>	6–10dx1 <sup>1</sup> / <sub>2</sub>	640	1725	1725	1725
DGHT	1¾ - 3 <sup>5</sup> / <sub>8</sub>	9 <sup>1</sup> / <sub>4</sub> - 24	2½	3 <sup>1</sup> / <sub>8</sub>	6–10dx2 <sup>1</sup> / <sub>2</sub>	4–10dx2 <sup>1</sup> / <sub>2</sub>	6–10dx1 <sup>1</sup> / <sub>2</sub>	830	2350	2350	2350
DGHT Stud Below <sup>5</sup>	1¾ - 7 <sup>1</sup> / <sub>8</sub>	9 <sup>1</sup> / <sub>4</sub> - 24	2½	3 <sup>1</sup> / <sub>8</sub>	6–10dx2 <sup>1</sup> / <sub>2</sub>	4–10dx2 <sup>1</sup> / <sub>2</sub>	6–10dx1 <sup>1</sup> / <sub>2</sub>	830	2485	2485	2485

For SI: 1 lb = 4.45 N, 1 inch = 25.4 mm.

<sup>1</sup>Refer to Figures 7a and 7b (this page) for definitions of hanger nomenclature (W, H, B, TF).

<sup>2</sup>Tabulated allowable load capacities must be selected based on duration of load as permitted by the applicable building code.

<sup>3</sup>Tabulated allowable loads are based on a wall assembly consisting of minimum 2x4 double top plate members with studs spaced not more than 16 inches on center. Top plate member splices must occur at stud location.

<sup>4</sup>Hangers spaced closer than 16 inches on center shall reduce capacity proportionately.

<sup>5</sup>DGHT allowable loads with studs below require a minimum 2x4 double stud in the wall centered on the hanger. Studs shall be design by a registered design professional.

<sup>6</sup>The uplift loads have been increased for wind or earthquake loading with no further increase allowed. The allowable uplift loads must be reduced when other load durations govern.

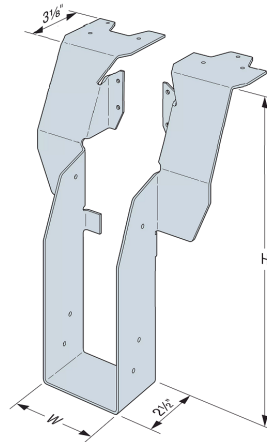

a. DGT HANGER (DGHT similar)

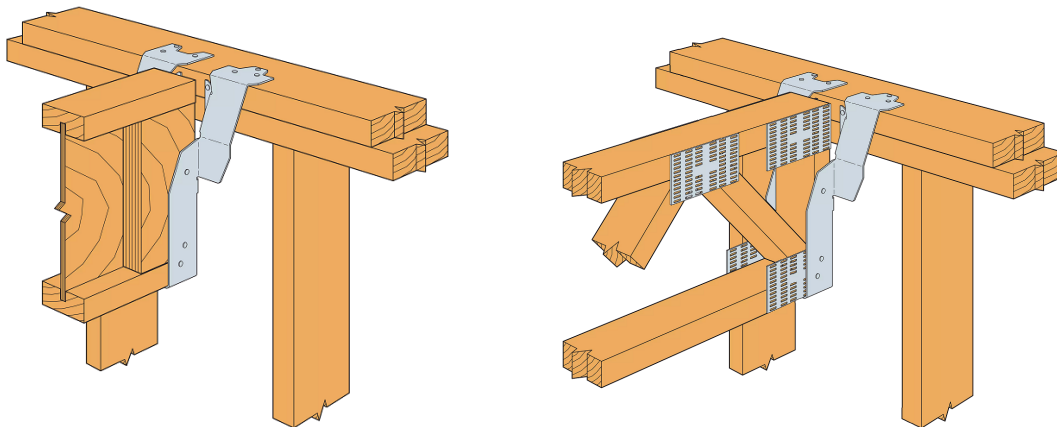

b. TYPICAL INSTALLATIONS

FIGURE 7—PRODUCT DRAWINGS AND TYPICAL INSTALLATIONS

DIVISION: 06 00 00—WOOD, PLASTICS AND COMPOSITES  
Section: 06 05 23—Wood, Plastic, and Composite Fastenings

**REPORT HOLDER:**

SIMPSON STRONG-TIE COMPANY INC.

**EVALUATION SUBJECT:**

SIMPSON STRONG-TIE® TOP-FLANGE HANGERS FOR SAWN LUMBER

**1.0 REPORT PURPOSE AND SCOPE****Purpose:**

The purpose of this evaluation report supplement is to indicate that Simpson Strong-Tie® top-flange hangers for sawn lumber, described in ICC-ES evaluation report [ESR-2553](#), have also been evaluated for compliance with the codes noted below as adopted by the Los Angeles Department of Building and Safety (LADBS).

**Applicable code editions:**

- 2023 *City of Los Angeles Building Code* (LABC)
- 2023 *City of Los Angeles Residential Code* (LARC)

**2.0 CONCLUSIONS**

The Simpson Strong-Tie® top-flange hangers for sawn lumber, described in Sections 2.0 through 7.0 of the evaluation report [ESR-2553](#), comply with the LABC Chapter 23, and the LARC, and are subjected to the conditions of use described in this supplement.

**3.0 CONDITIONS OF USE**

The Simpson Strong-Tie® top-flange hangers for sawn lumber, described in this evaluation report supplement must comply with all of the following conditions:

- All applicable sections in the evaluation report [ESR-2553](#).
- The design, installation, conditions of use and identification are in accordance with the 2021 *International Building Code*® (2021 IBC) provisions noted in the evaluation report [ESR-2553](#).
- The design, installation and inspection are in accordance with additional requirements of LABC Chapters 16 and 17, as applicable.
- The supported end of joist or beam must be within 1/4-inch from the supporting member.
- Solid blocking must be required for all joist hangers supporting roof joists having one end twisted more than one-half degree per foot of length relative to the other end, except as specifically noted in the evaluation report.
- Under the LARC, an engineered design in accordance with LARC Section R301.1.3 must be submitted.

This supplement expires concurrently with the evaluation report, reissued January 2024.

**DIVISION: 06 00 00—WOOD, PLASTICS, AND COMPOSITES**  
**Section: 06 05 23—Wood, Plastic, and Composite Fastenings**

**REPORT HOLDER:**

**SIMPSON STRONG-TIE COMPANY INC.**

**EVALUATION SUBJECT:**

**SIMPSON STRONG-TIE® TOP-FLANGE HANGERS FOR SAWN LUMBER**

**1.0 REPORT PURPOSE AND SCOPE**

**Purpose:**

The purpose of this evaluation report supplement is to indicate that the Simpson Strong-Tie® top-flange hangers, described in ICC-ES evaluation report ESR-2553, have also been evaluated for compliance with the codes noted below.

**Applicable code editions:**

- 2023 *Florida Building Code—Building*
- 2023 *Florida Building Code—Residential*

**2.0 CONCLUSIONS**

The Simpson Strong-Tie® top-flange hangers, described in Sections 2.0 through 7.0 of ICC-ES evaluation report ESR-2553, comply with the *Florida Building Code—Building*, and the *Florida Building Code—Residential*. The design requirements must be determined in accordance with the *Florida Building Code—Building* or the *Florida Building Code—Residential*, as applicable. The installation requirements noted in ICC-ES evaluation report ESR-2553 for the 2021 *International Building Code*® meet the requirements of the *Florida Building Code—Building* or the *Florida Building Code—Residential*, as applicable.

Use of the Simpson Strong-Tie® top-flange hangers has also been found to be in compliance with the High-Velocity Hurricane Zone provisions of the *Florida Building Code—Building*, and the *Florida Building Code—Residential* with the following condition:

- a. For connections subject to uplift, the connection must be designed for no less than 700 pounds (3114 N).

For products falling under Florida Rule 61G20-3, verification that the report holder's quality assurance program is audited by a quality assurance entity approved by the Florida Building Commission for the type of inspections being conducted is the responsibility of an approved validation entity (or the code official when the report holder does not possess an approval by the Commission).

This supplement expires concurrently with the evaluation report ESR-2553, reissued January 2024.