

ICC-ES Evaluation Report

ESR-2604

Reissued January 2024

This report also contains:

- FBC Supplement

Subject to renewal January 2025

- LABC Supplement

ICC-ES Evaluation Reports are not to be construed as representing aesthetics or any other attributes not specifically addressed, nor are they to be construed as an endorsement of the subject of the report or a recommendation for its use. There is no warranty by ICC Evaluation Service, LLC, express or implied, as to any finding or other matter in this report, or as to any product covered by the report.

Copyright © 2024 ICC Evaluation Service, LLC. All rights reserved.

<p>DIVISION: 06 00 00— WOOD, PLASTICS AND COMPOSITES</p> <p>Section: 06 05 23— Wood, Plastic, and Composite Fastenings</p>	<p>REPORT HOLDER: SIMPSON STRONG-TIE COMPANY INC.</p> 	<p>EVALUATION SUBJECT: SIMPSON STRONG-TIE® COLUMN CAPS AND POST CAPS FOR WOOD CONSTRUCTION</p>	
--	--	---	---

1.0 EVALUATION SCOPE

Compliance with the following codes:

- 2021, 2018, 2015, and 2012 [International Building Code® \(IBC\)](#)
- 2021, 2018, 2015, and 2012 [International Residential Code® \(IRC\)](#)

For evaluation for compliance with codes adopted by [Los Angeles Department of Building and Safety \(LADBS\)](#) see [ESR-2604 LABC and LARC Supplement](#).

Property evaluated:

Structural

2.0 USES

The Simpson Strong-Tie® CC/ECC column caps ([Table 1](#)) and the CCQ/ECCQ column caps ([Table 2](#)) are used to connect wood beams to wood posts and timbers in engineered applications in accordance with Section [2403.10.4](#) of the 2021 IBC, Section [2304.10.3](#) of the 2018 and 2015 IBC, or Section [2304.9.3](#) of the 2012 and 2009 IBC or Section [R301.1.3](#) of the IRC. The AC/ACE/ACH post caps ([Table 3](#)), LPC post caps ([Table 4](#)), PC/EPC post caps ([Table 5](#)), and the BC/BCS post caps ([Table 6](#)) are used to provide a positive connection between post-and-beam construction used to support wood framing members to resist uplift forces and lateral displacement of the beam in accordance with Section [2304.10.8](#) of the 2021 IBC, Section [2304.10.7](#) of the 2018 and 2015 IBC, or Section [2304.9.7](#) of the 2012 and 2009 IBC and Section [R502.9](#) of the IRC.

3.0 DESCRIPTION

3.1 General—Column Caps and Post Caps

3.1.1 CC/ECC Column Caps: The CC3^{1/4}, ECC3^{1/4}, CC4, ECC4, CC4.62, ECC4.62, CC6 and ECC6 are fabricated from two No. 7 gage steel straps factory welded to a No. 7 gage steel U-shaped channel, where ³/₁₆-inch-thick (4.8 mm) by 2¹/₂-inch-long (63.5 mm) fillet welds are located on one side of each strap attached to the U-channel. All other CC/ECC column caps are fabricated from two No. 3 gage steel straps factory welded to a No. 3 gage steel U-shaped channel, where ¹/₄-inch-thick (6.4 mm) by 2¹/₂-inch-long (63.5 mm) fillet welds are located on one side of each strap attached to the U-channel. Column caps with fillet welds on both sides of each strap are available. The ECC column caps are designed for use at beam ends. See [Table 1](#) for column

cap models, dimensions, required quantity and diameter of bolts, and allowable loads. See [Figure 1](#) for a drawing of a typical CC column cap connector and the ECC44 end column connector.

3.1.2 CCQ/ECCQ Quick Drive Column Caps: The CCQ3, ECCQ3, CCQ4, ECCQ4, CCQ4.62, ECCQ4.62, CCQ6, and ECCQ6 are fabricated from two No. 7 gage steel straps factory welded to a No. 7 gage steel U-shaped channel, where $\frac{3}{16}$ -inch-thick (4.8 mm) by $2\frac{1}{2}$ -inch-long (63.5 mm) fillet welds are located on one side of each strap attached to the U-channel. The CCQ5, ECCQ5, CCQ7, ECCQ7, CCQ7.1, ECCQ7.1, CCQ8, ECCQ8, CCQ9, ECCQ9, CC10, and ECCQ10 column caps are fabricated from two No. 3 gage steel straps factory welded to a No. 3 gage steel U-shaped channel, where $\frac{1}{4}$ -inch-thick (6.4 mm) by $2\frac{1}{2}$ -inch-long (63.5 mm) fillet welds are located on one side of each strap attached to the U-channel. Column caps with fillet welds on both sides of each strap are available. The ECCQ column caps are used to connect the end of a beam to a post. See [Table 2](#) for column cap models, dimensions, required quantity of SDS $\frac{1}{4} \times 2\frac{1}{2}$ screws, and allowable loads. See [Figure 2](#) for a drawing of a CCQ46-SDS2.5 column cap, a typical installation of a CCQ46-SDS2.5 column cap, and of an ECCQ46-SDS2.5 end column cap connector.

3.1.3 AC/ACE/ACH Post Caps: The AC and ACE are two-piece post caps fabricated from No. 18 gage galvanized steel. The ACH are two-piece post caps fabricated from No. 16 gage galvanized steel. The AC/ACE/ACH post caps must be used in pairs and in locations where the supported beam is continuous over the wood post. ACE post caps are used to connect the end of a beam to a post. The ACH can be bent to connect the end of a beam to a post. See [Table 3](#) for dimensions, minimum (MIN) and maximum (MAX) fastener schedules, and allowable uplift and lateral loads corresponding to the minimum and maximum fastener schedules. See [Figure 3a](#) for a drawing of a typical AC post cap, [Figure 3b](#) for a drawing of a typical installation of an ACE post cap showing the “left” and “right” pieces of the post cap assembly, [Figure 3c](#) for a drawing of a typical installation of an ACH and [Figure 3d](#) for a typical installation of an ACH installed at the end of a beam.

3.1.4 LPC Light Post Caps: The LPC6 and LPC4 post caps are two-piece post caps fabricated from No. 16 gage and No. 18 gage galvanized steel respectively. The LPC post caps must be used in pairs and in locations where the supported beam is continuous over the wood post. The LPC post caps are designed to be used with wood beams having a width less than the supporting wood post, and can connect continuous beams or the end of beams to a post provided the required nails are installed. Both LPC post caps described in this report have a model designation ending with the letter Z, indicating they have a G185 zinc coating in accordance with [ASTM A653](#). See [Table 4](#) for the connector width for the supporting wood post, required fasteners, and allowable uplift and lateral loads. See [Figure 4](#) for a drawing of a typical LPC post cap connector, and a typical installation where the supported wood beam is continuous over the wood post.

3.1.5 Post Caps: The PC/EPC and PCZ/EPCZ post caps are one-piece connectors. PC44-16 (EPC44-16), PC46-16 (EPC46-16), PC48-16 (EPC48-16), PC64-16 (EPC64-16), PC66-16 (EPC66-16), PC4Z (EPC4Z), PC4RZ (EPC4RZ), PC6Z (EPC6Z), PC6RZ (EPC6RZ), PC8Z (EPC8Z), and the PC8RZ (EPC8RZ) are fabricated from No.16 gage galvanized steel. The PC and PCZ are designed to connect a beam to a post and the EPC and EPCZ are designed to connect the end of a beam to a post. See [Table 5](#) for model numbers, post cap dimensions, fastener options and allowable uplift and lateral loads. See [Figure 5](#) for drawings of typical PC/EPC and PCZ/EPCZ post caps and typical installation drawings.

3.1.6 BC/BCS Post Caps: The BC/BCS post caps are one-piece connectors fabricated from No. 18 gage galvanized steel. The BCS2-2/4 post cap is designed for the connection of double 2x's to a nominally 4-inch-wide post, and the BCS2-3/6 post cap is designed for the connection of triple 2x's to a nominally 6-inch-wide post. The BC/BCS post caps are designed to be used with built-up wood beams having a width less than the post width, and can connect continuous beams or the end of beams to a post provided the required nails are installed. See [Table 6](#) for model numbers, post cap dimensions, required fasteners, and allowable uplift and lateral loads. See [Figure 6](#) for drawings of a BC4 post cap and a BCS2-2/4 post cap, and a drawing of a typical installation of a BCS2-2/4 post cap.

3.2 Materials:

3.2.1 Steel: The galvanized connectors described in this report are manufactured from galvanized sheet steel complying with ASTM A653, SS designation, Grade 33, with a minimum specified yield strength, F_y , of 33 ksi and tensile strength, F_u , of 45 ksi. The CC/ECC and CCQ/ECCQ column cap connectors are manufactured from steel complying with [ASTM A1011](#), SS designation, Grade 33, with minimum specified yield strength, F_y , of 33 ksi and tensile strength, F_u , of 52 ksi and a painted finish. Base-metal thicknesses for the connectors in this report are as follows:

NOMINAL THICKNESS (Gage)	MINIMUM BASE METAL THICKNESS (inches)
No. 3 ¹	0.2285
No. 7 ¹	0.1705
No. 16 ²	0.0555
No. 18 ²	0.0445

For SI: 1 inch = 25.4 mm.

¹Base-metal thickness for steel conforming to ASTM A1011.

²Base-metal thickness for steel conforming to ASTM A653.

Some connectors (designated with a model number ending with Z) are available with a G185 zinc coating specification in accordance with ASTM A653. Some models (designated with a model number ending with HDG) are available with a hot-dip galvanization, also known as “batch” galvanization, in accordance with [ASTM A123](#), with a minimum specified coating weight of 2.0 ounces of zinc per square foot of surface area (610 g/m²), total for both sides. Model numbers in this report do not include the Z or HDG ending (except for [Table 4](#)), but the information shown applies. The lumber treater and the holder of this report (Simpson Strong-Tie Company) should be contacted for recommendations on the appropriate coating or material to specify for use of the steel connectors in contact with the specific proprietary preservative treated or fire retardant treated lumber.

3.2.2 Wood: Wood members with which the connectors are used must be either sawn lumber or engineered lumber having a minimum specific gravity of 0.50 (minimum equivalent specific gravity of 0.50 for engineered lumber), and having a maximum moisture content of 19 percent (16 percent for engineered lumber) except as noted in Section [4.1](#). The thickness of the supporting wood member must be equal to or greater than the length of the fasteners specified in the tables in this report, or as required by wood member design, whichever is greater. For installation in engineered wood members, minimum allowable nail spacing and end and edge distances, as specified in the applicable evaluation report for the engineered wood product, must be met.

3.2.3 Fasteners: Nails used with connectors described in this report must be bright or hot-dipped galvanized carbon steel nails complying with [ASTM F1667](#) with minimum fastener dimensions and bending yield strengths (F_{yb}) shown in the following table. Alternatively, nails of other materials or finishes may be used when they are recognized in an ICC-ES evaluation report as having bending yield strength and withdrawal capacity equal to or better than those of a bright carbon steel nail of the same nominal diameter.

FASTENER	SHANK DIAMETER (inches)	NAIL LENGTH (inches)	F_{yb} (psi)
10d	0.148	3	90,000
16d	0.162	3½	90,000

For SI: 1 inch = 25.4 mm, 1 psi = 6.895 kPa.

For the CC/ECC/ECCU connectors, bolts are to be Standard Hex Bolts complying with ANSI/ASME B18.2.1, and, at a minimum, must comply with [ASTM A36](#) or [A307](#).

SDS screws are Simpson Strong-Tie® Strong-Drive® screws that comply with [ESR-2236](#). SDS screws, where required in the report, are provided with the connector. SD10212 screws are Simpson Strong-Tie® Strong-Drive® screws that comply with [ESR-3046](#).

Nails used in contact with preservative-treated or fire-retardant-treated lumber must be hot-dipped galvanized carbon steel nails. Alternatively, nails of other materials or finishes may be used when they are recognized in an ICC-ES evaluation report for use in the applicable treated lumber.

Bolts used in contact with preservative treated or fire retardant treated lumber must comply with Section [2304.10.6](#) of the 2021 IBC, Section [2304.10.5](#) of the 2018 or 2015 IBC, Section [2304.9.5](#) of the 2012, and 2009 IBC, or Section [R317.3](#) IRC, as applicable. SDS screws used in contact with preservative-treated or fire-retardant-treated lumber must, as a minimum, comply with ESR-2236. For use with treated lumber, the lumber treater or this report holder (Simpson Strong-Tie Company), or both, should be contacted for recommendations on the appropriate coating or material to specify for the fasteners as well as the connection capacities of fasteners used with the specific proprietary preservative treated or fire retardant treated lumber. Nails and bolts required in this evaluation report are not provided with the connectors.

4.0 DESIGN AND INSTALLATION

4.1 Design:

The tabulated allowable loads shown in the product tables of this report are based on Allowable Stress Design (ASD) and include the load duration factor, C_D , corresponding with the applicable loads in accordance with the *National Design Specification[®] for Wood Construction* (NDS and its Supplement).

Tabulated allowable loads apply to products connected to wood used under dry conditions and where sustained temperatures are 100°F (37.8°C) or less. When products are installed to wood having a moisture content greater than 19 percent (16 percent for engineered wood products), or where wet service is expected, the allowable loads must be adjusted by the wet service factor, C_M , specified in the NDS for dowel-type fasteners. When connectors are installed in wood that will experience sustained exposure to temperatures exceeding 100°F (37.8°C), the allowable loads in this report must be adjusted by the applicable temperature factor, C_t , specified in the NDS. Connected wood members must be analyzed for load-carrying capacity at the connection in accordance with the NDS.

4.2 Installation:

Installation of the connectors must be in accordance with this evaluation report and the manufacturer's published installation instructions. In the event of a conflict between this report and the manufacturer's published installation instructions, this report governs.

5.0 CONDITIONS OF USE:

The Simpson Strong-Tie connectors described in this report comply with, or are suitable alternatives to what is specified in, those codes listed in Section [1.0](#) of this report, subject to the following conditions:

- 5.1 The connectors must be manufactured, identified and installed in accordance with this report and the manufacturer's published installation instructions. A copy of the instructions must be available at the jobsite at all times during installation.
- 5.2 Calculations showing compliance with this report must be submitted to the code official. The calculations must be prepared by a registered design professional where required by the statutes of the jurisdiction in which the project is to be constructed
- 5.3 Adjustment factors noted in Section 4.1 and the applicable codes must be considered, where applicable.
- 5.4 Connected wood members and fasteners must comply, respectively, with Sections [3.2.2](#) and [3.2.3](#) of this report.
- 5.5 Use of connectors with preservative treated or fire retardant treated lumber must be in accordance with Section [3.2.1](#) of this report. Use of fasteners with preservative treated or fire retardant treated lumber must be in accordance with Section [3.2.3](#) of this report.
- 5.6 Welded connectors are manufactured under a quality control program with inspections by ICC-ES.

6.0 EVIDENCE SUBMITTED

Data in accordance with the [ICC-ES Acceptance Criteria for Joist Hangers and Similar Devices \(AC13\)](#), dated March 2018 (editorially revised December 2020).

7.0 IDENTIFICATION

- 7.1 The products described in this report are identified with a die-stamped label or an adhesive label indicating the name of the manufacturer (Simpson Strong-Tie), the model number, and the number of an index evaluation report ([ESR-2523](#)) that is used as an identifier for the products recognized in this report. Additionally, the factory-welded connectors manufactured in the United States and Canada are identified with the acronym of the inspection agency (ICC-ES).
- 7.2 The report holder's contact information is the following:

SIMPSON STRONG-TIE COMPANY INC.
5956 WEST LAS POSITAS BOULEVARD
PLEASANTON, CALIFORNIA 94588
(800) 925-5099
www.strongtie.com

TABLE 1—CC AND ECC SERIES COLUMN CAPS

MODEL NO.	Width for Beam (W ₁) (in.)	Width for Post (W ₂) (in.)	COLUMN CAP DIMENSIONS (inches)				BOLTS ¹					ALLOWABLE LOADS ^{2,3,4} (lbs)			
							Bearing Length for Beam (L)			U-Channel Height for Beam (H ₁)	Size (in.)	Quantity			Post
			CC	ECC	ECCU	Beam			C _D = 1.6			Download ^{8,9,10}			
						CC	ECC	ECCU					C _D = 1.0		
CC3 ¹ / ₄ -4	3 ¹ / ₄	3 ⁵ / ₈	11	7 ¹ / ₂	9 ¹ / ₂	6 ¹ / ₂	5 ⁵ / ₈	4	2	4	2	3,150	16,980	6,835	6,835
CC3 ¹ / ₄ -6		5 ¹ / ₂	11	7 ¹ / ₂	9 ¹ / ₂	6 ¹ / ₂	5 ⁵ / ₈	4	2	4	2	3,150	21,485	10,740	10,740
CC44	3 ⁵ / ₈	3 ⁵ / ₈	7	5 ¹ / ₂	6 ¹ / ₂	4	5 ⁵ / ₈	2	1	4	2	1,850	19,020	7,655	7,655
CC46		5 ¹ / ₂	11	8 ¹ / ₂	9 ¹ / ₂	6 ¹ / ₂	5 ⁵ / ₈	4	2	4	2	3,530	24,065	12,030	12,030
CC48		7 ¹ / ₂	11	8 ¹ / ₂	9 ¹ / ₂	6 ¹ / ₂	5 ⁵ / ₈	4	2	4	2	3,530	24,065	16,405	16,405
CC4.62-3.62	4 ⁵ / ₈	3 ⁵ / ₈	11	8 ¹ / ₂	9 ¹ / ₂	6 ¹ / ₂	5 ⁵ / ₈	4	2	4	2	4,535	23,390	9,845	9,845
CC4.62-4.62		4 ⁵ / ₈	11	8 ¹ / ₂	9 ¹ / ₂	6 ¹ / ₂	5 ⁵ / ₈	4	2	4	2	4,535	30,070	12,655	12,655
CC4.62-5.50		5 ¹ / ₂	11	8 ¹ / ₂	9 ¹ / ₂	6 ¹ / ₂	5 ⁵ / ₈	4	2	4	2	4,535	30,940	15,470	15,470
CC5 ¹ / ₄ -4	5 ¹ / ₄	3 ⁵ / ₈	13	9 ¹ / ₂	10 ¹ / ₂	8	3 ³ / ₄	4	2	4	2	6,300	26,635	11,210	11,210
CC5 ¹ / ₄ -6		5 ¹ / ₂	13	9 ¹ / ₂	10 ¹ / ₂	8	3 ³ / ₄	4	2	4	2	6,500	28,190	17,615	17,615
CC5 ¹ / ₄ -8		7 ¹ / ₂	13	9 ¹ / ₂	10 ¹ / ₂	8	3 ³ / ₄	4	2	4	2	6,645	35,235	24,025	24,025
CC64	5 ¹ / ₂	3 ⁵ / ₈	11	7 ¹ / ₂	9 ¹ / ₂	6 ¹ / ₂	5 ⁵ / ₈	4	2	4	2	5,545	28,585	12,030	12,030
CC66		5 ¹ / ₂	11	7 ¹ / ₂	9 ¹ / ₂	6 ¹ / ₂	5 ⁵ / ₈	4	2	4	2	5,545	33,275	18,905	18,905
CC68		7 ¹ / ₂	11	9 ¹ / ₂	9 ¹ / ₂	6 ¹ / ₂	5 ⁵ / ₈	4	2	4	2	5,545	37,815	25,780	25,780
CC6-7 ¹ / ₈		7 ¹ / ₈	11	9 ¹ / ₂	9 ¹ / ₂	6 ¹ / ₂	5 ⁵ / ₈	4	2	4	2	5,545	37,815	24,490	24,490
CC74	6 ⁷ / ₈	3 ⁵ / ₈	13	10 ¹ / ₂	10 ¹ / ₂	8	3 ³ / ₄	4	2	4	2	6,330	33,490	15,355	15,355
CC76		5 ¹ / ₂	13	10 ¹ / ₂	10 ¹ / ₂	8	3 ³ / ₄	4	2	4	2	6,790	37,125	24,130	24,130
CC77		6 ⁷ / ₈	13	10 ¹ / ₂	10 ¹ / ₂	8	3 ³ / ₄	4	2	4	2	7,020	48,265	29,615	29,615
CC78		7 ¹ / ₂	13	10 ¹ / ₂	10 ¹ / ₂	8	3 ³ / ₄	4	2	4	2	7,145	48,265	32,090	32,905
CC7 ¹ / ₈ -4	7 ¹ / ₈	3 ⁵ / ₈	13	10 ¹ / ₂	10 ¹ / ₂	8	3 ³ / ₄	4	2	4	2	6,360	34,730	18,375	18,375
CC7 ¹ / ₈ -6		5 ¹ / ₂	13	10 ¹ / ₂	10 ¹ / ₂	8	3 ³ / ₄	4	2	4	2	6,825	38,500	28,875	28,875
CC7 ¹ / ₈ -7 ¹ / ₈		7 ¹ / ₈	13	10 ¹ / ₂	10 ¹ / ₂	8	3 ³ / ₄	4	2	4	2	7,105	57,750	36,750	36,750
CC7 ¹ / ₈ -8		7 ¹ / ₂	13	10 ¹ / ₂	10 ¹ / ₂	8	3 ³ / ₄	4	2	4	2	7,190	52,500	39,375	39,375
CC84	8 ⁷ / ₈	3 ⁵ / ₈	13	10 ¹ / ₂	10 ¹ / ₂	8	3 ³ / ₄	4	2	4	2	6,410	37,210	16,405	16,405
CC86		5 ¹ / ₂	13	10 ¹ / ₂	10 ¹ / ₂	8	3 ³ / ₄	4	2	4	2	6,885	41,250	25,780	25,780
CC88		7 ¹ / ₂	13	10 ¹ / ₂	10 ¹ / ₂	8	3 ³ / ₄	4	2	4	2	7,250	51,565	35,155	35,155
CC94	8 ⁷ / ₈	3 ⁵ / ₈	13	10 ¹ / ₂	10 ¹ / ₂	8	3 ³ / ₄	4	4	4	2	6,580	47,545	19,905	19,905
CC96		5 ¹ / ₂	13	10 ¹ / ₂	10 ¹ / ₂	8	3 ³ / ₄	4	4	4	2	7,080	48,125	31,280	31,280
CC98		7 ¹ / ₂	13	10 ¹ / ₂	10 ¹ / ₂	8	3 ³ / ₄	4	4	4	2	7,455	62,565	42,655	42,655
CC106	9 ¹ / ₂	5 ¹ / ₂	13	10 ¹ / ₂	10 ¹ / ₂	8	3 ³ / ₄	4	4	4	2	7,160	52,250	32,655	32,655

For SI: 1 inch = 25.4 mm, 1 lbs = 4.45 N.

¹ECC has one-half the tabulated beam bolts. ECC9 and ECC10 have four beam bolts. Bolt holes bored into the wood beam and post must be no less than 1/32 inch greater and no more than 1/16 inch greater than the diameter of the bolt. See Section 3.2.3. (Bolts are not provided with the CC/ECC/ECCU connectors.)

²Tabulated allowable load must be selected based on duration of load as permitted by the applicable building code.

³The wood post depth must be equal to the wood beam width (W₁).

⁴If structural composite lumber posts are used, installation of the fasteners into the wide face (fasteners perpendicular to the strands/veneers) is required in order to obtain the loads listed in this report. The structural composite lumber must have an ICC-ES report that shows fastener design specific gravity equivalent of 0.50 or better.

⁵The uplift loads have been increased for wind or earthquake loading with no further increase allowed. The allowable loads must be reduced when other load durations govern.

⁶Allowable uplift loads for the CC column caps do not apply to spliced beam conditions.

⁷Allowable uplift loads assume a beam height of 11 inches to ensure minimum edge distance for the top bolts in the U-shaped channel loaded perpendicular to the grain of the wood beam.

⁸Allowable downloads are for beams that are continuous over the length (L) of the CC connector.

⁹When a spliced beam condition occurs, that is, where the ends of two beams are supported by the post and connected to the CC post cap connector, the splice must occur at the middle of the connector and the maximum allowable download for each spliced beam is one half of the tabulated allowable download. When spliced beams must be connected together to transfer design tension loads (i.e., lateral loads parallel to the beams), the connection must be by means other than the column cap.

¹⁰Tabulated allowable download is based on the lesser capacity determined from compression-perpendicular-to-grain stress (F_{c⊥}) for the supported beam of 560 psi for glulam and 625 psi for DF-L sawn lumber, as applicable, and the following compression-parallel-to-grain stress (F_{c||}) for the wood post: 1,650 psi for glulam, 1,350 psi for 4-inch-wide (W₂ dimension) sawn lumber, and 1,000 psi for 5-inch-wide and wider (W₂ dimension) sawn lumber, as applicable. Allowable loads may not be increased for short-term loading.

¹¹Allowable uplift loads require the supported beam member having a minimum shear parallel-to-grain, F_v, of 180 psi, such as for DF-L sawn lumber.

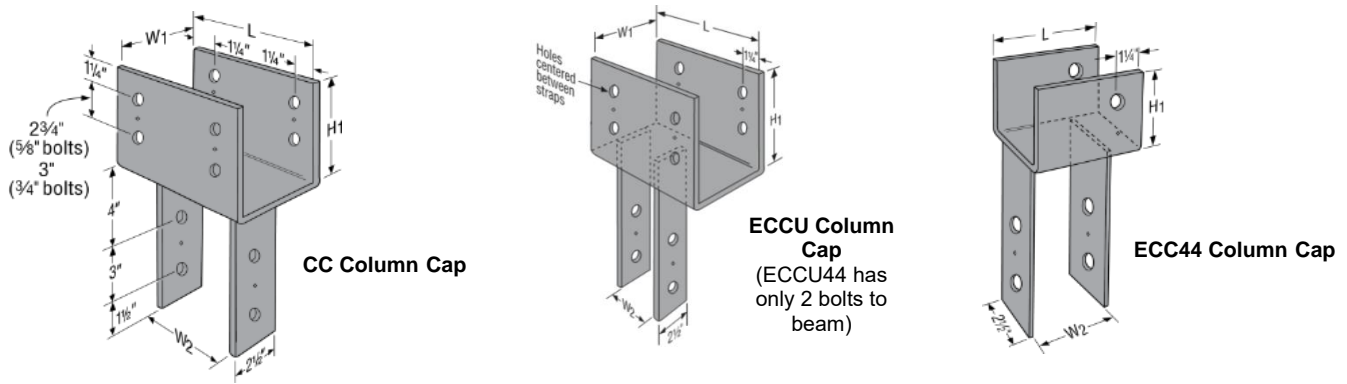

FIGURE 1—CC AND ECC COLUMN CAPS

TABLE 2—CCQ AND ECCQ SERIES COLUMN CAPS

MODEL NO.	COLUMN CAP DIMENSIONS (inches)				QUANTITY OF SDS ¹ / ₄ x 2 ¹ / ₂ SCREWS ¹	ALLOWABLE LOADS ^{2,3,4,5} (lbs)						
	Width for Beam (W ₁) (in.)	Width for Post (W ₂) (in.)	Bearing Length for Beam (L) (in.)			U-Channel Height for Beam (H ₁) (in.)	Into Beam	Into Post	CCQ	ECCQ ⁶	CCQ	ECCQ ⁶
			CCQ	ECCQ					Uplift ^{6,7,8}		Download ^{9,10,11,12}	
									C _D =1.6	C _D =1.6	C _D =1.0	
CCQ3-4SDS2.5	3 ¹ / ₄	3 ⁵ / ₈	11	8 ¹ / ₂	7	16	14	5,370	3,465	16,980	6,125	
CCQ3-6SDS2.5		5 ¹ / ₂						5,370	3,465	21,485	10,740	
CCQ44SDS2.5	3 ⁵ / ₈	3 ⁵ / ₈	11	8 ¹ / ₂	7	16	14	5,370	3,785	19,020	7,655	
CCQ46SDS2.5		5 ¹ / ₂						6,785	3,785	24,065	12,030	
CCQ48SDS2.5		7 ¹ / ₂						6,785	3,785	24,065	16,405	
CCQ4.62-3.62SDS	4 ⁵ / ₈	3 ⁵ / ₈	11	8 ¹ / ₂	7	16	14	5,370	3,785	23,390	9,845	
CCQ4.62-4.62SDS		4 ⁵ / ₈						5,370	3,785	30,070	12,655	
CCQ4.62-5.50SDS		5 ¹ / ₂						6,785	3,785	30,940	15,470	
CCQ5-4SDS2.5	5 ¹ / ₄	3 ⁵ / ₈	11	8 ¹ / ₂	7	16	14	5,370	4,040	26,635	11,210	
CCQ5-6SDS2.5		5 ¹ / ₂						6,785	5,355	28,190	17,615	
CCQ5-8SDS2.5		7 ¹ / ₂						6,785	5,355	35,235	24,025	
CCQ64SDS2.5	5 ¹ / ₂	3 ⁵ / ₈	11	8 ¹ / ₂	7	16	14	5,370	3,785	28,585	12,030	
CCQ66SDS2.5		5 ¹ / ₂						6,785	3,785	33,275	18,905	
CCQ68SDS2.5		7 ¹ / ₂						6,785	3,785	37,815	25,780	
CCQ6-7.13SDS2.5		7 ¹ / ₈						6,785	3,785	37,815	24,490	
CCQ74SDS2.5	6 ⁷ / ₈	3 ⁵ / ₈	11	8 ¹ / ₂	7	16	14	5,370	4,040	33,490	15,355	
CCQ76SDS2.5		5 ¹ / ₂						6,785	5,355	37,125	24,130	
CCQ77SDS2.5		6 ⁷ / ₈						6,785	5,355	48,265	29,615	
CCQ78SDS2.5		7 ¹ / ₂						6,785	5,355	48,265	32,905	
CCQ7.1-4SDS2.5	7 ¹ / ₈	3 ⁵ / ₈	11	8 ¹ / ₂	7	16	14	5,370	4,040	34,730	18,375	
CCQ7.1-6SDS2.5		5 ¹ / ₂						6,785	5,355	38,500	28,875	
CCQ7.1-7SDS2.5		7 ¹ / ₈						6,785	5,355	57,750	36,750	
CCQ7.1-8SDS2.5		7 ¹ / ₂						6,785	5,355	52,500	39,375	
CCQ84SDS2.5	7 ¹ / ₂	3 ⁵ / ₈	11	8 ¹ / ₂	7	16	14	6,785	5,355	37,210	16,405	
CCQ86SDS2.5		5 ¹ / ₂						6,785	5,355	41,250	25,780	
CCQ88SDS2.5		7 ¹ / ₂						6,785	5,355	51,565	35,155	
CCQ94SDS2.5	8 ⁷ / ₈	3 ⁵ / ₈	11	8 ¹ / ₂	7	16	14	6,785	5,355	47,545	19,905	
CCQ96SDS2.5		5 ¹ / ₂						6,785	5,355	48,125	31,280	
CCQ98SDS2.5		7 ¹ / ₂						6,785	5,355	62,565	42,655	
CCQ106SDS2.5	9 ¹ / ₂	5 ¹ / ₂	11	8 ¹ / ₂	7	16	14	6,785	5,355	52,250	32,655	

For SI: 1 inch = 25.4 mm, 1 lbs = 4.45 N.

¹The model number for the SDS¹/₄x2¹/₂ is SDS25250 (see ESR-2236). The screws are included as components of the CCQ/ECCQ column caps.

²Tabulated allowable load must be selected based on duration of load as permitted by the applicable building code.

³The wood post depth must be equal to the wood beam width (W₁).

⁴If structural composite lumber posts are used, installation of the fasteners into the wide face (fasteners perpendicular to the strands/veneers) is required in order to obtain the loads listed in this report. The structural composite lumber must have an ICC-ES report that shows fastener design specific gravity equivalent of 0.50 or better.

⁵ECCQ uses 14–SDS 1/4 x 2 1/2 screws into the beam and 14–SDS 1/4 x 2 1/2 screws into the post.

⁶The uplift loads have been increased for wind or earthquake loading with no further increase allowed. The allowable loads must be reduced when other load durations govern.

⁷Allowable uplift loads for the CCQ column caps do not apply to spliced beam conditions.

⁸Allowable uplift loads assume a minimum beam height of 7 inches to ensure minimum edge distance for the top SDS screws in the U-shaped channel loaded perpendicular to the grain of the wood beam.

⁹Allowable downloads for beams that are continuous over the length (L) of the CCQ connector.

¹⁰When a spliced beam condition occurs, that is, where the ends of two beams are supported by the post and connected to the CCQ post cap connector, the splice must occur at the middle of the connector and the maximum allowable download for each spliced beam is one half of the tabulated allowable download. When spliced beams must be connected together to transfer design tension loads (i.e., lateral loads parallel to the beams), the connection must be by means other than the column cap.

¹¹Tabulated allowable download is based on the lesser capacity determined from compression-perpendicular-to-grain stress ($F_{c\perp}$) for the supported beam of 560 psi for glulam and 625 psi for DF-L sawn lumber, as applicable, and the following compression-parallel-to-grain stress ($F_{c\parallel}$) for the wood post: 1,550 psi for glulam, 1,350 psi for 4-inch-wide (W_2 dimension) sawn lumber, and 1,000 psi for 5-inch-wide and wider (W_2 dimension) sawn lumber, as applicable.

¹²Allowable downloads may not be increased for short-term loading.

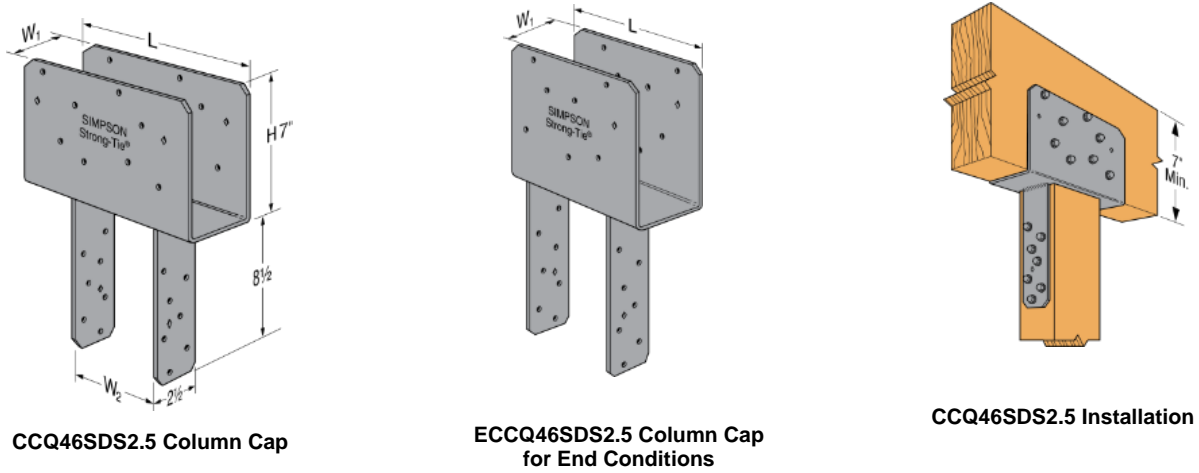

FIGURE 2—CCQ AND ECCQ COLUMN CAPS

TABLE 3—AC, ACE, AND ACH POST CAPS

MODEL NO. ^{1,2}		POST CAP DIMENSIONS (inches)		NAILS (Quantity—Type)		ALLOWABLE LOADS ^{3,4,5} (lbs)	
		W	L	Into the Beam	Into the Post	Uplift ⁶ C _D = 1.6	Lateral ⁷ C _D = 1.6
AC4	MIN	3 ⁹ / ₁₆	6 ¹ / ₂	8 – 16d	8 – 16d	1,745	1,610
	MAX			14 – 16d	14 – 16d	2,490	1,475
AC4R	MIN	4	7	8 – 16d	8 – 16d	1,745	1,610
	MAX			14 – 16d	14 – 16d	2,490	2,075
ACE4	MIN	—	4 ¹ / ₂	6 – 16d	6 – 16d	1,235	750
	MAX			10 – 16d	10 – 16d	1,950	1,265
ACH4Z	-	3 ⁹ / ₁₆	6 ¹ / ₂	20-16dx2 ¹ / ₂	20-16dx2 ¹ / ₂	4,045	1,765
	-			20-SD10212	20-SD10212	5,895	2,595
ACH4Z (END)	-	3 ⁹ / ₁₆	6 ¹ / ₂	20-16dx2 ¹ / ₂	20-16dx2 ¹ / ₂	2,580	1,360
	-			20-SD10212	20-SD10212	2,680	1,815
AC6	MIN	5 ¹ / ₂	8 ¹ / ₂	8 – 16d	8 – 16d	1,665	1,565
	MAX			14 – 16d	14 – 16d	2,815	2,075
AC6R	MIN	6	9	8 – 16d	8 – 16d	1,665	1,565
	MAX			14 – 16d	14 – 16d	3,055	2,450
ACE6	MIN	—	6 ¹ / ₂	6 – 16d	6 – 16d	1,235	835
	MAX			10 – 16d	10 – 16d	1,950	1,760
ACH6Z	-	5 ¹ / ₂	8 ¹ / ₂	20-16dx2 ¹ / ₂	20-16dx2 ¹ / ₂	4,045	2,640
	-			20-SD10212	20-SD10212	5,895	4,130
ACH6Z (END)	-	5 ¹ / ₂	8 ¹ / ₂	20-16dx2 ¹ / ₂	20-16dx2 ¹ / ₂	2,580	1,965
	-			20-SD10212	20-SD10212	2,680	2,200

For **SI**: 1 inch = 25.4 mm, 1 lbs = 4.45 N.

¹“MIN” suffix to the model No. indicates that only the round holes must be filled with the quantity and type of nails specified in the table to achieve the tabulated allowable load values.

²“MAX” suffix to the model No. indicates that both round and triangular holes must be filled with the quantity of nails specified in the table to achieve the tabulated allowable load values.

³The allowable uplift loads do not apply to splice conditions. When a spliced beam condition occurs, that is, where the ends of two beams are supported by the wood post and connected to the AC post cap connector, the condition must be designed and detailed to transfer the tension (lateral) loads by means other than the post cap.

⁴Allowable uplift and lateral loads apply only for AC, ACE and ACH post cap connectors installed in pairs, as shown in [Figure 3b](#), [Figure 3c](#) and [Figure 3d](#) with each piece connected to the wood post and beam with an equal amount and type of fasteners.

⁵Allowable uplift and lateral loads have been increased for wind or earthquake loading with no further increase allowed. The allowable loads must be reduced when other load durations govern.

⁶Allowable lateral loads are parallel to the length of the supported wood beam, as shown in [Figure 3b](#).

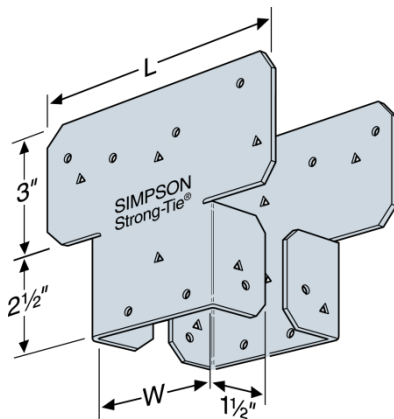

FIGURE 3a—AC POST CAP CONNECTOR COMPONENTS

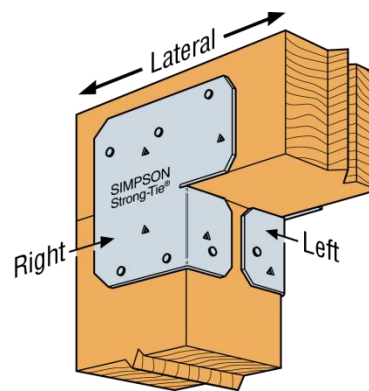

FIGURE 3b—TYPICAL ACE INSTALLATION

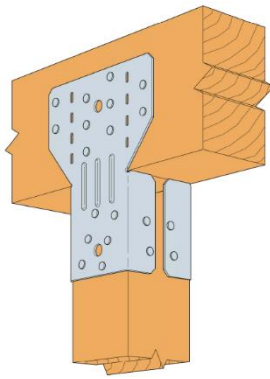

FIGURE 3c TYPICAL ACH INSTALLATION

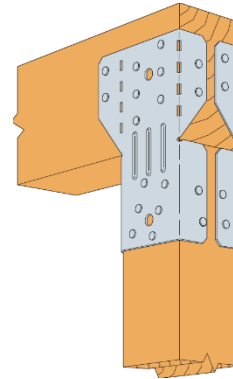

FIGURE 3d TYPICAL ACH (END) INSTALLATION

FIGURE 3—AC, ACE AND ACH POST CAPS

TABLE 4—LPC LIGHT POST CAPS^{1,2}

MODEL NO.	CONNECTOR WIDTH FOR WOOD POST (inches)	NAILS (Quantity-Type)		ALLOWABLE LOADS ^{3,4,5} (lbs.)	
		Into the Beam	Into the Post	Uplift ⁶	Lateral ⁷
				C _D = 1.6	C _D = 1.6
LPC4Z	3 ⁹ / ₁₆	8 –10d	8 –10d	755	760
LPC6Z	5 ⁹ / ₁₆	8 –10d	8 –10d	920	885

For SI: 1 inch = 25.4 mm, 1 lbs = 4.45 N.

¹The LPCZ post cap is a two-piece wood-beam-to-post connector that is designed to be used with wood beams having a width less than the post width, as implied in [Figure 4](#).

²The LPC4 and LPC6 models shown in the table end with the letter Z, indicating that they have a G185 zinc coating in accordance with [ASTM A653](#).

³The allowable uplift loads do not apply to spliced beams, that is, where the ends of two beams are supported by the wood post and connected to the LPC post cap connector. A spliced beam condition must be designed and detailed to transfer the tension load (i.e., tabulated allowable lateral loads) by means other than the column cap.

⁴Allowable uplift and lateral loads apply only for LPC post cap connectors installed in pairs, as shown in [Figure 4](#), with each piece connected to the wood post and beam with an equal amount and type of nails.

⁵Allowable uplift and lateral loads have been increased for wind or earthquake loading with no further increase allowed. The allowable loads must be reduced when other load durations govern.

⁶Allowable uplift loads for the LPC column caps do not apply to spliced beam conditions.

⁷Allowable lateral loads are parallel to the length of the supported wood beam, as shown in [Figure 4](#).

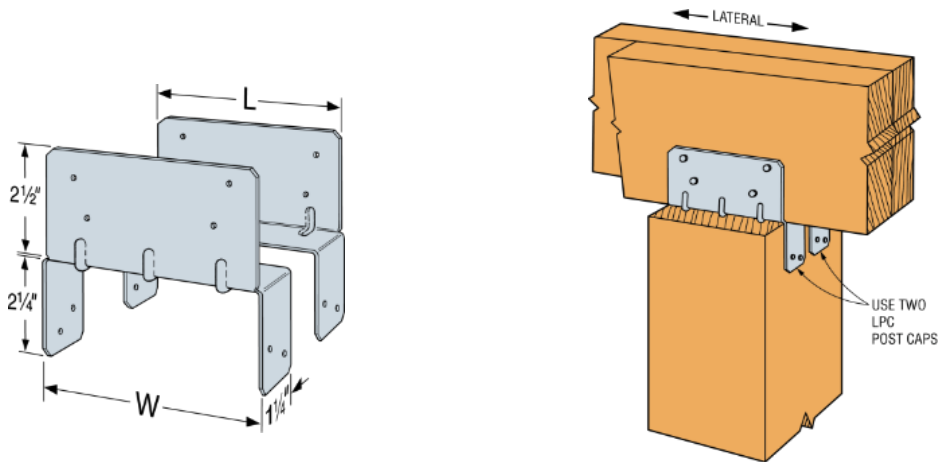

FIGURE 4—LPCZ POST CAPS

TABLE 5—PC/EPC & PCZ/EPCZ SERIES POST CAPS^{1,2}

MODEL NO.	Min. Post Size (in)	POST CAP DIMENSIONS (in)					NAILS ^{8,9} (Quantity-Type)			ALLOWABLE LOADS ^{3,4,5} (lbs)			
		Width for Beam (W ₁)	Width for Post (W ₂)	Metal Flange Lengths			Into The Post	PC & PCZ Post Cap	EPC & EPCZ Post Cap	PC & PCZ		EPC & EPCZ	
				PC/EPC & PCZ/EPCZ	PC & PCZ	EPC & EPCZ				Uplift ⁶	Lateral ⁷	Uplift ⁶	Lateral ⁷
				L ₁	L ₂	L ₃				C _D = 1.6	C _D = 1.6	C _D = 1.6	C _D = 1.6
PC44-16	4x4	3 ⁹ / ₁₆	3 ⁹ / ₁₆	2 ⁵ / ₈	11	7 ³ / ₈	8-16d	12-16d	8-16d	1,025	970	1,025	970
PC46-16	4x6		5 ¹ / ₂	2 ⁵ / ₈	13	9 ¹ / ₄	8-16d	12-16d	8-16d	1,025	970	1,025	970
PC48-16	4x8		7 ¹ / ₂	2 ⁵ / ₈	15	11 ¹ / ₄	8-16d	16-16d	12-16d	1,025	1,270	1,025	1,270
PC64-16	4x6	5 ¹ / ₂	3 ⁹ / ₁₆	4 ⁹ / ₁₆	11	7 ³ / ₈	8-16d	12-16d	8-16d	1,025	970	1,025	970
PC66-16	6x6		5 ¹ / ₂	4 ⁹ / ₁₆	13	9 ¹ / ₄	8-16d	12-16d	12-16d	1,025	970	1,025	970
PC4Z	4x4	3 ⁹ / ₁₆	-	2 ⁵ / ₈	7	5 ¹ / ₄	8-10d	10-10d	10-10d	1,480	1,260	1,130	1,075
	4x6						8-10d	10-10d	10-10d	1,480	1,260	1,130	1,230
	4x8						8-10d	10-10d	10-10d	1,480	1,380	1,130	1,230
PC4RZ	4x4	4	-	2 ⁵ / ₈	7	5 ¹ / ₄	8-10d	10-10d	10-10d	1,480	1,260	1,130	1,075
	4x6						8-10d	10-10d	10-10d	1,480	1,260	1,130	1,230
	4x8						8-10d	10-10d	10-10d	1,480	1,380	1,130	1,230
PC6Z	4x4	5 ¹ / ₂	-	2 ⁵ / ₈	7	5 ¹ / ₄	8-10d	10-10d	10-10d	1,480	1,260	1,435	1,075
	4x6						8-10d	10-10d	10-10d	1,480	1,295	1,435	1,230
	4x8						8-10d	10-10d	10-10d	1,480	1,380	1,435	1,230
PC6RZ	4x4	6	-	2 ⁵ / ₈	7	5 ¹ / ₄	8-10d	10-10d	10-10d	1,480	1,260	1,435	1,075
	4x6						8-10d	10-10d	10-10d	1,480	1,295	1,435	1,230
	4x8						8-10d	10-10d	10-10d	1,480	1,380	1,435	1,230
PC8Z	4x4	7 ¹ / ₂	-	2 ⁵ / ₈	7	5 ¹ / ₄	8-10d	10-10d	10-10d	1,480	1,260	1,435	1,075
	4x6						8-10d	10-10d	10-10d	1,480	1,295	1,435	1,230
	4x8						8-10d	10-10d	10-10d	1,480	1,380	1,435	1,230
PC8RZ	4x4	8	-	2 ⁵ / ₈	7	5 ¹ / ₄	8-10d	10-10d	10-10d	1,480	1,260	1,435	1,075
	4x6						8-10d	10-10d	10-10d	1,480	1,295	1,435	1,230
	4x8						8-10d	10-10d	10-10d	1,480	1,380	1,435	1,230

For SI: 1 inch = 25.4 mm, 1 lbs = .45 N.

¹The PCZ and EPCZ models shown in the table end with the letter Z, indicating that they have a G185 zinc coating in accordance with ASTM A653.

²The PCRZ and EPCRZ models shown in the table with the letter R, indicating that they are for rough cut sawn lumber.

³Allowable loads have been increased for wind or earthquake load with no further increase allowed; reduce where other loads govern.

⁴Post and beam may consist of multiple members provided members are connected independently of the post cap fasteners. The designer must determine the fasteners required to join members without splitting the wood.

⁵Spliced conditions must be detailed by the designer to transfer tension loads between spliced members by means other than the column cap.

⁶Allowable uplift loads for the PC and PCZ column caps do not apply to spliced beam conditions.

⁷Allowable lateral loads are parallel to the length of the supported wood beam, as shown in [Figure 5](#).

⁸Applies to PCZ and EPCZ models only: 10d x 2¹/₂ long nails may be used with no reduction for uplift and 0.85 of the table loads for lateral.

⁹Applies to PCZ and EPCZ models only: SD9 = 0.131" dia. X 1 1/2" long screws may be used with no load reduction to table loads and PCZ uplift load of 1930 lbs.

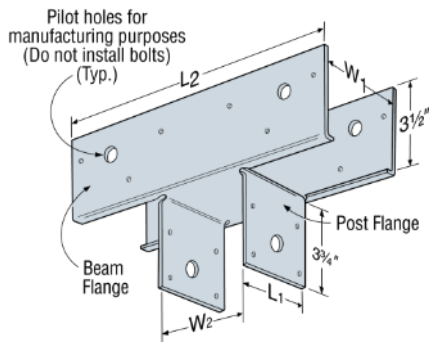

PC Post Cap

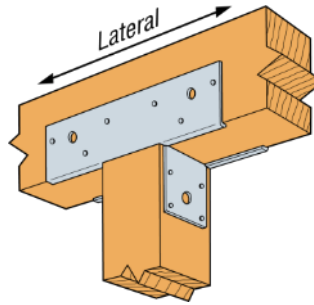

Typical PC Post Cap Installation

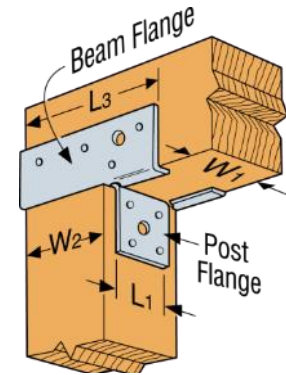

Typical EPC End Post Cap Installation

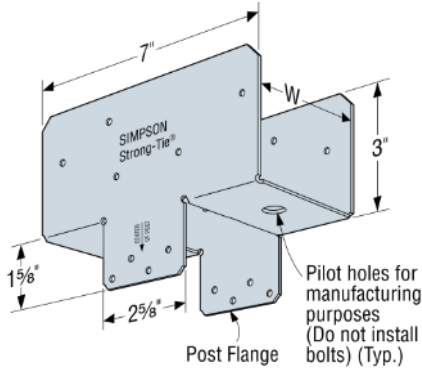

PCZ Post Cap

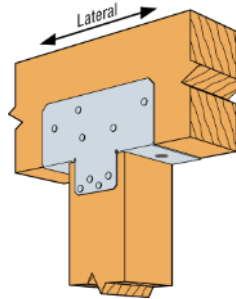

Typical PCZ Post Cap Installation

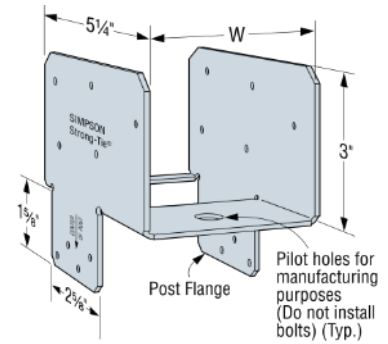

EPCZ End Post Cap

FIGURE 5—PC/EPC AND PCZ/EPCZ POST CAPS

TABLE 6—BC AND BCS POST CAPS¹

MODEL NO.	POST CAPS DIMENSIONS (in.)						NAILS ² (Quantity-Type)		ALLOWABLE LOADS ^{3,4}	
	Width for Beam (W ₁)	Width for Post (W ₂)	Metal Flange Length		Metal Flange Height		Into the Wood Beam	Into the Wood Post	Uplift ⁵	Lateral ⁶
			Beam (L ₁)	Post (L ₂)	Beam (H ₁)	Post (H ₂)			C _D = 1.6	C _D = 1.6
BC4	3 ⁹ / ₁₆	3 ⁹ / ₁₆	2 ⁷ / ₈	2 ⁷ / ₈	3	3	6 –16d	6 –16d	605	1,000
BC46	3 ⁹ / ₁₆	5 ¹ / ₂	4 ⁷ / ₈	4 ⁷ / ₈	3 ¹ / ₂	2 ¹ / ₂	12 –16d	6 –16d	945	1,000
BC4R	4	4	4	4	3	3	12 –16d	12 –16d	605	1,000
BC6	5 ¹ / ₂	5 ¹ / ₂	4 ³ / ₈	4 ³ / ₈	3 ³ / ₈	3 ³ / ₈	12 –16d	12 –16d	1,185	1,825
BC6R	6	6	6	6	3	3	12 –16d	12 –16d	1,185	1,825
BC8	7 ¹ / ₂	7 ¹ / ₂	7 ¹ / ₂	7 ¹ / ₂	4	4	12 –16d	12 –16d	1,660	1,825
BCS2-2/4	3 ¹ / ₈	3 ⁹ / ₁₆	2 ⁷ / ₈	2 ⁷ / ₈	2 ¹⁵ / ₁₆	2 ¹⁵ / ₁₆	8 –10d	6 –10d	895	890
BCS2-3/6	4 ⁵ / ₈	5 ⁹ / ₁₆	4 ³ / ₈	2 ⁷ / ₈	3 ¹⁵ / ₁₆	2 ¹⁵ / ₁₆	12 –16d	6 –16d	895	1,330

For SI: 1 inch = 25.4 mm, 1 lbs = 4.45 N.

¹The BCS2-2/4 post cap is designed for the connection of double 2x's to a nominally 4-inch-wide post, and the BCS2-3/6 post cap is designed for the connection of triple 2x's to a nominally 6-inch-wide post.

²The BCS has slant nail holes for nails that must be installed into the beam at a 45-degree angle and penetrate into the end grain of the supporting post. Nails must be minimum 3 1/2-inches long (i.e., 16d common nails).

³Tabulated allowable load capacities must be selected based on duration of load as permitted by the applicable building code.

⁴Spliced beams, where the ends of two beams are supported by the wood post and connected to the BC post cap connector, are not permitted. The supported wood beam must be continuous.

⁵Allowable uplift and lateral loads have been increased for wind or earthquake loading with no further increase allowed. The allowable loads must be reduced when other load durations govern.

⁶Allowable lateral loads are parallel to the length of the supported wood beam, as shown in [Figure 6](#).

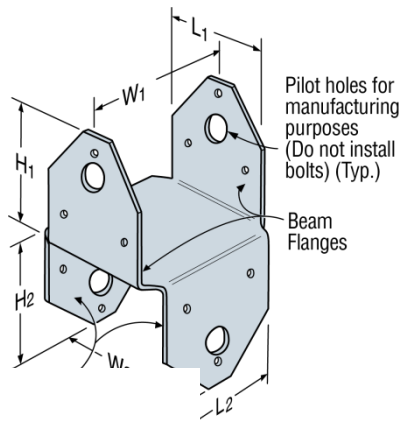

Typical BCS Post Cap Installation

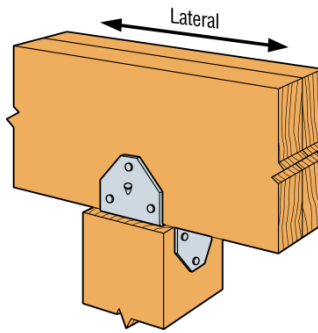

BCS2-2/4 Post Cap
U.S. Patent
5,603,580

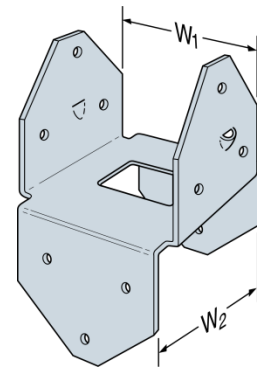

Slant Nail Holes,
typical both sides.
(See footnote 2)

FIGURE 6—BC AND BCS POST CAPS

DIVISION: 06 00 00—WOOD, PLASTICS AND COMPOSITES
Section: 06 05 23—Wood, Plastic, and Composite Fastenings

REPORT HOLDER:

SIMPSON STRONG-TIE COMPANY INC.

EVALUATION SUBJECT:

SIMPSON STRONG-TIE® COLUMN CAPS AND POST CAPS FOR WOOD CONSTRUCTION

1.0 REPORT PURPOSE AND SCOPE**Purpose:**

The purpose of this evaluation report supplement is to indicate that Simpson Strong-Tie® column caps and post caps for wood construction, described in ICC-ES evaluation report [ESR-2604](#), have also been evaluated for compliance with the codes noted below as adopted by the Los Angeles Department of Building and Safety (LADBS).

Applicable code editions:

- 2023 *City of Los Angeles Building Code* (LABC)
- 2023 *City of Los Angeles Residential Code* (LARC)

2.0 CONCLUSIONS

The Simpson Strong-Tie® column caps and post caps for wood construction, described in Sections 2.0 through 7.0 of the evaluation report [ESR-2604](#), comply with the LABC Chapter 23, and the LARC, and are subjected to the conditions of use described in this supplement.

3.0 CONDITIONS OF USE

The Simpson Strong-Tie® column caps and post caps for wood construction, described in this evaluation report supplement must comply with all of the following conditions:

- All applicable sections in the evaluation report [ESR-2604](#).
- The design, installation, conditions of use and labeling are in accordance with the 2021 *International Building Code*® (IBC) provisions noted in the evaluation report [ESR-2604](#).
- The design, installation and inspection are in accordance with additional requirements of LABC Chapters 16 and 17, as applicable.
- The connections are not approved to resist uplift forces from wood shear walls.
- Allowable loads must be reduced when load durations with lower value Cd (than what is in the tables) govern.
- Under the LARC, an engineered design in accordance with LARC Section R301.1.3 must be submitted.

This supplement expires concurrently with the evaluation report, reissued January 2024.

DIVISION: 06 00 00—WOOD, PLASTICS, AND COMPOSITES
Section: 06 05 23—Wood, Plastic, and Composite Fastenings

REPORT HOLDER:

SIMPSON STRONG-TIE COMPANY INC.

EVALUATION SUBJECT:

SIMPSON STRONG-TIE® COLUMN CAPS AND POST CAPS FOR WOOD CONSTRUCTION

1.0 REPORT PURPOSE AND SCOPE**Purpose:**

The purpose of this evaluation report supplement is to indicate that the Simpson Strong-Tie® column caps and post caps for wood construction, described in ICC-ES evaluation report ESR-2604, have also been evaluated for compliance with the codes noted below.

Applicable code editions:

- 2023 *Florida Building Code—Building*
- 2023 *Florida Building Code—Residential*

2.0 CONCLUSIONS

The Simpson Strong-Tie® column caps and post caps for wood construction, described in Sections 2.0 through 7.0 of ICC-ES evaluation report ESR-2604, comply with the *Florida Building Code—Building*, and the *Florida Building Code—Residential*. The design requirements must be determined in accordance with the *Florida Building Code—Building* or the *Florida Building Code—Residential*, as applicable. The installation requirements noted in ICC-ES evaluation report ESR-2604 for the 2021 *International Building Code*® meet the requirements of the *Florida Building Code—Building* or the *Florida Building Code—Residential*, as applicable.

Use of the Simpson Strong-Tie® column caps and post caps for wood construction has also been found to be in compliance with the High-Velocity Hurricane Zone provisions of the *Florida Building Code—Building*, and the *Florida Building Code—Residential* with the following condition:

- a. For connections subject to uplift, the connection must be designed for no less than 700 pounds (3114 N).

For products falling under Florida Rule 61G20-3, verification that the report holder's quality assurance program is audited by a quality assurance entity approved by the Florida Building Commission for the type of inspections being conducted is the responsibility of an approved validation entity (or the code official when the report holder does not possess an approval by the Commission).

This supplement expires concurrently with the evaluation report ESR-2604, reissued January 2024.